

SHC

Multifunction Module Kit

IE

**Instructions and
recommendations**

Installer

Maintenance technician

1.042861ENG

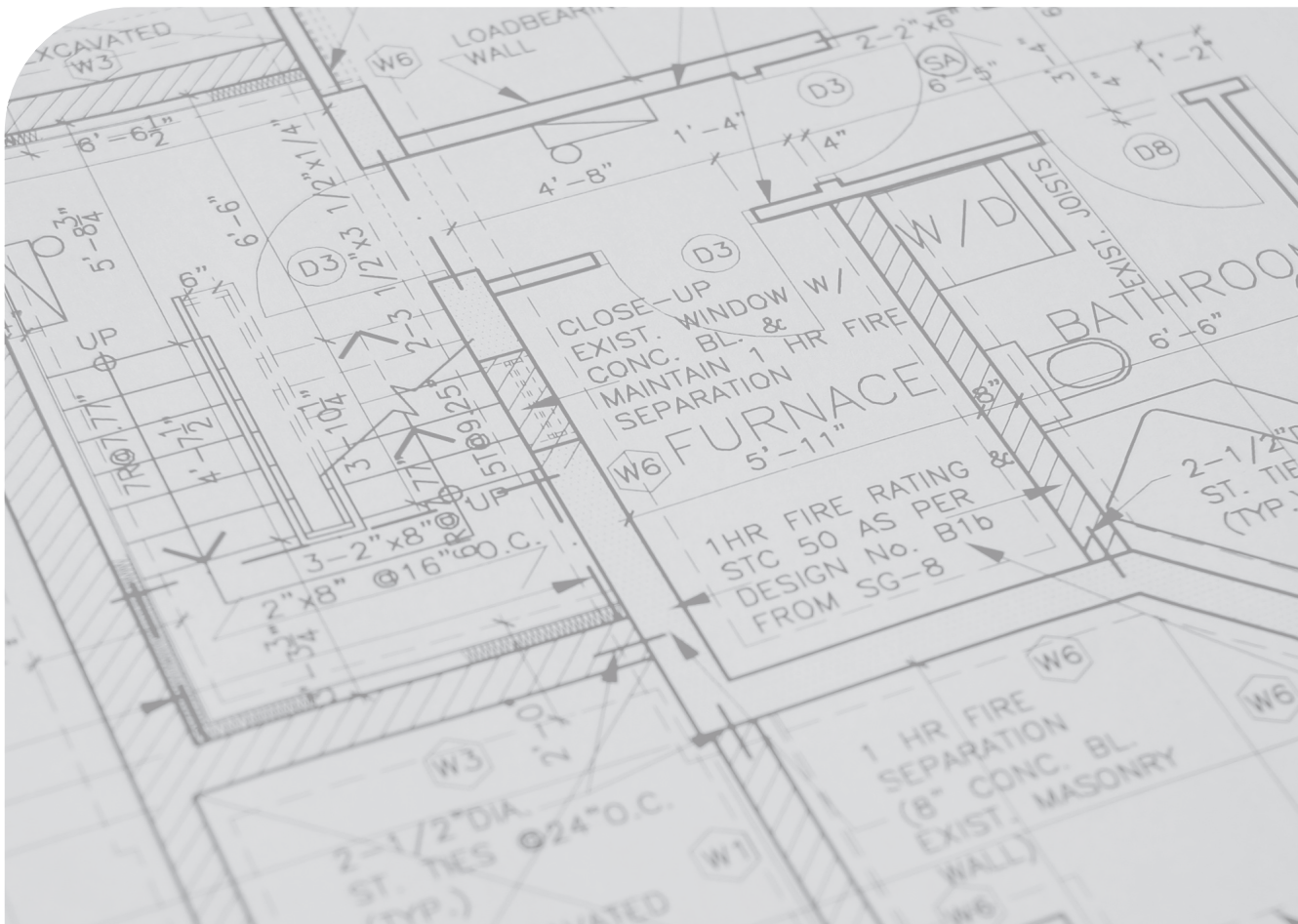

INDEX

1	General information	3
2	Composition	4
3	Application	5
3.1	Connections	6
3.2	Electricity supply.....	7
3.3	data Connection.....	7
3.4	Services.....	8
3.5	Practical wiring CH services.....	10
3.6	Practical wiring DHW services.....	11
3.7	Practical solar storage tank connection	13
3.8	Types of system	14
3.9	Operating check.....	15
3.10	Heating.....	15
3.11	Domestic Hot Water.....	15
3.12	Solar.....	15
4	Data communication	16
5	Parameters	17
6	Structure of the system	20
6.1	Operating modes	20
6.2	Simultaneous CH and DHW supply	20
7	eBUS communication	21
7.1	Power supply.....	22
7.2	Communication between the HC and the SHCs.....	22
7.3	Multi-function module communication	22
8	Installation examples	23
9	Diagnostics	43

1 GENERAL INFORMATION.

The board is designed as a multi-function support for heating systems. It should be considered part of a modular system joined by an eBUS or Modbus communication system.

Its input and output resources make it suitable for a variety of applications:

1. Direct or mixed heating circuits
2. Domestic hot water with storage tank.
3. Domestic hot water with plate heat exchanger.
4. Domestic hot water with plate heat exchanger and mixing valve
5. Solar collector with tank.

The multi-function module interacts with the system like a user, whose demands must be met by a manager controller, which is responsible for the running of the heat generator.



2 COMPOSITION.

The multi-function module kit consists of:

- Panel
- NTC temperature sensor (3 pcs.)
- Technical assembly instructions



3 APPLICATION.

The multi-function module resources can be configured entirely by the software, to provide the main services requested by a heating system.

The services provided by the multi-function module are selected during installation within the limitations of the input and output resources of the device:

Code	Description
CH1Mix	Mixed heating circuit #1
CH2Mix	Mixed heating circuit #2
CH1	Direct heating circuit #1
CH2	Direct heating circuit #2
CH3	Direct heating circuit #3
DHWS	Domestic hot water tank
DHWI	Plate heat exchanger for domestic hot water
DHWmix	Plate heat exchanger for mixed domestic hot water.
COMBI	Mixed heating circuit and mixed domestic hot water with plate heat exchanger and diverter valve.
Solar	Solar collector with storage tank



3.1 CONNECTIONS.

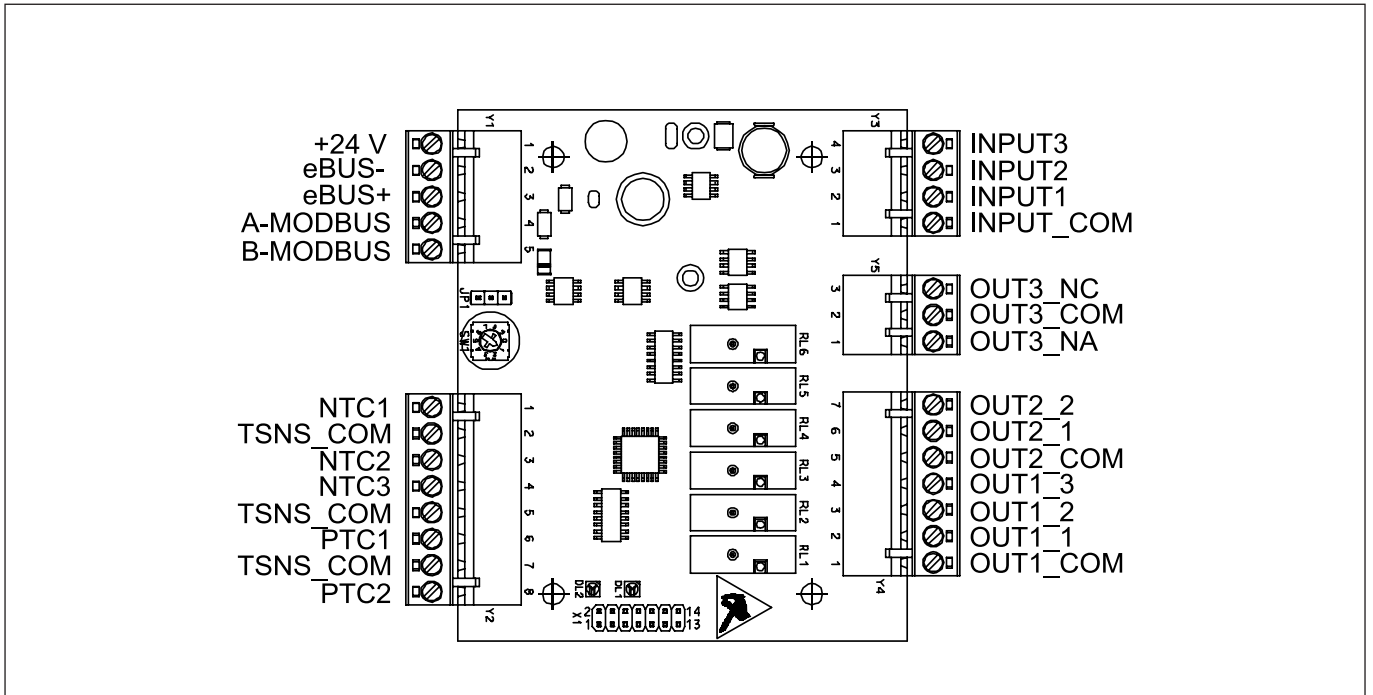

Available resources:

- 3 inputs for NTC 10 KOhm @25°C (supplied)
- 2 PT1000 inputs
- 3 enabling inputs with 1 common (for voltage-free contacts)
- 3 outputs with voltage-free contacts and 1 common
- 2 outputs with voltage-free contacts and 1 common
- 1 output with change-over contact and 1 common

The outputs consist of voltage-free contacts with 3 common connections as shown in the diagram below.

When the contacts have to operate services powered at 230 V directly, the power supply phase has to be directed towards the common connection, considering the maximum current of contacts of 1 A.

For higher loads, remote control switches must be introduced, which can be operated at either high or low voltage.

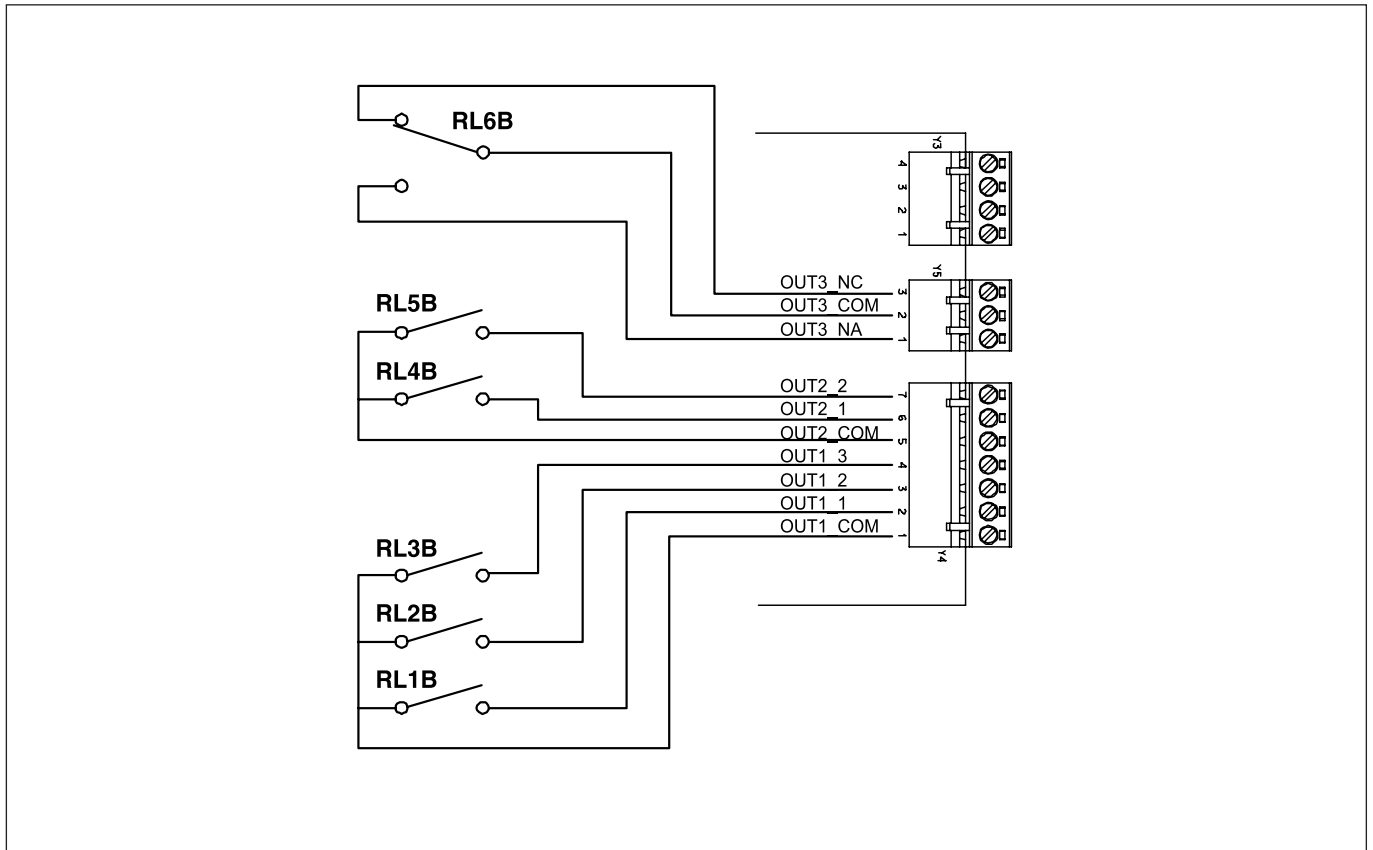

3.2 ELECTRICITY SUPPLY.

The module requires an external power supply with a minimum of 20 VDC and a maximum of 35 VDC capable of dispensing 2 W for every module connected.

A power supply code 00362379 may also be used, which is capable of powering 5 modules simultaneously.

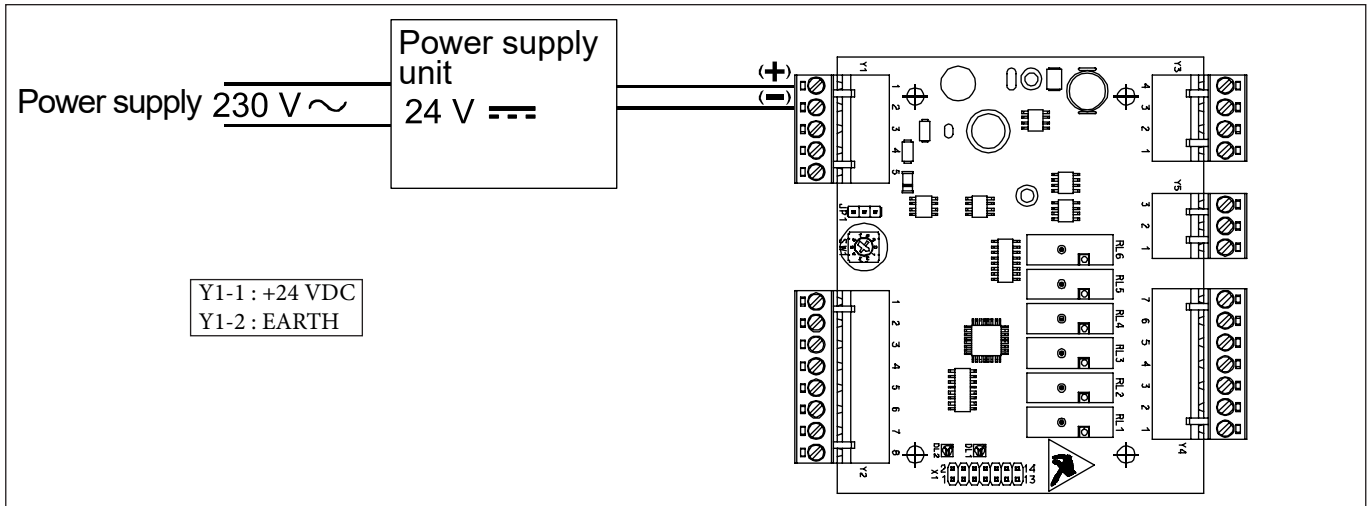

3.3 DATA CONNECTION.

Via eBUS

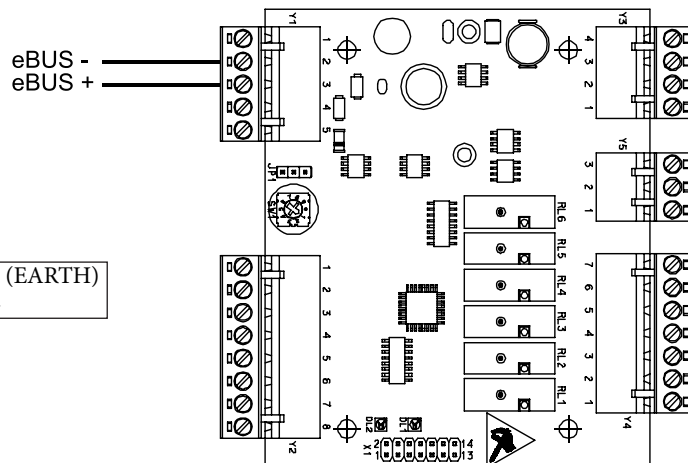

Via MODBUS

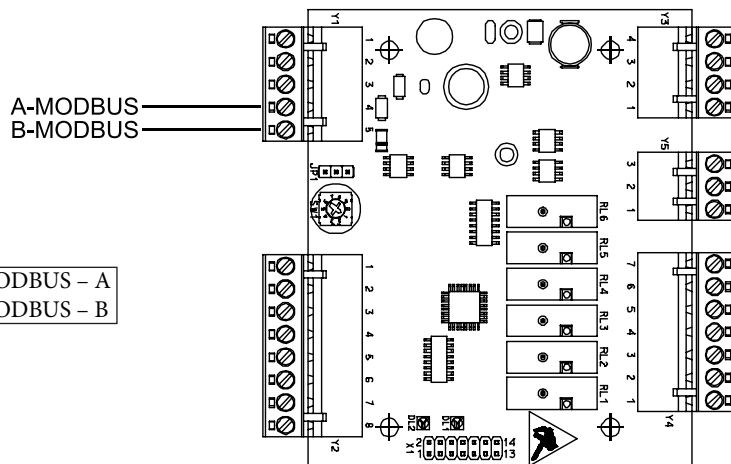

APPLICATION

3.4 SERVICES.

The services installed determine the usage of the multi-function module resources, according to the following tables:

CH Services								
	CH1 Mix	CH2 Mix	Combi	CH1	CH2	CH3	CH1 Valve	Alarm
Out 1_1		Hot					Valve	Alarm
Out 1_2		Cold			Pump			
Out 1_3	Pump		Pump	Pump				
Out 2_1	Hot		Hot					
Out 2_2	Cold		Cold					
Out 3		Pump	TWV-CH			Pump		
Input 1	ON/OFF		CH ON/OFF	ON/OFF				
Input 2		ON/OFF			ON/OFF			
Input 3			Rich. DW			ON/OFF		
NTC 1	Mixer		DHW					
NTC 2		Mixer	Mixer					
NTC 3								
PTC1								
PTC2								

DHW Services							
	DHW Mix	DHWS Mix	DHWS Mix1	DHWS	DHWS 1	DHWS 2	Alarm
Out 1_1							Alarm
Out 1_2						Pump	
Out 1_3	Pump	Pump	Pump		Pump		
Out 2_1	Hot	Hot	Hot				
Out 2_2	Cold	Cold	Cold				
Out 3				Pump			
Input 1					ON/OFF		
Input 2						ON/OFF	
Input 3	Request	Request	Request	ON/OFF			
NTC 1	DHW	DHW			Tank		
NTC 2			DHW			Tank	
NTC 3		Tank	Tank	Tank			
PTC1							
PTC2							



Solar Storage Tank				
	Solar 1	Solar 2	Sun Heat	Alarm
Out 1_1		Pump		Alarm
Out 1_2	Pump			
Out 1_3				
Out 2_1				
Out 2_2				
Out 3			TWV-Tank	
Input 1				
Input 2				
Input 3				
NTC 1	Tank Bot	Tank Bot		
NTC 2			Tank Inlet	
NTC 3	Tank Top	Tank Top	Tank Top	
PTC1	Collector 1			
PTC2		Collector 2		



3.5 PRACTICAL WIRING CH SERVICES.

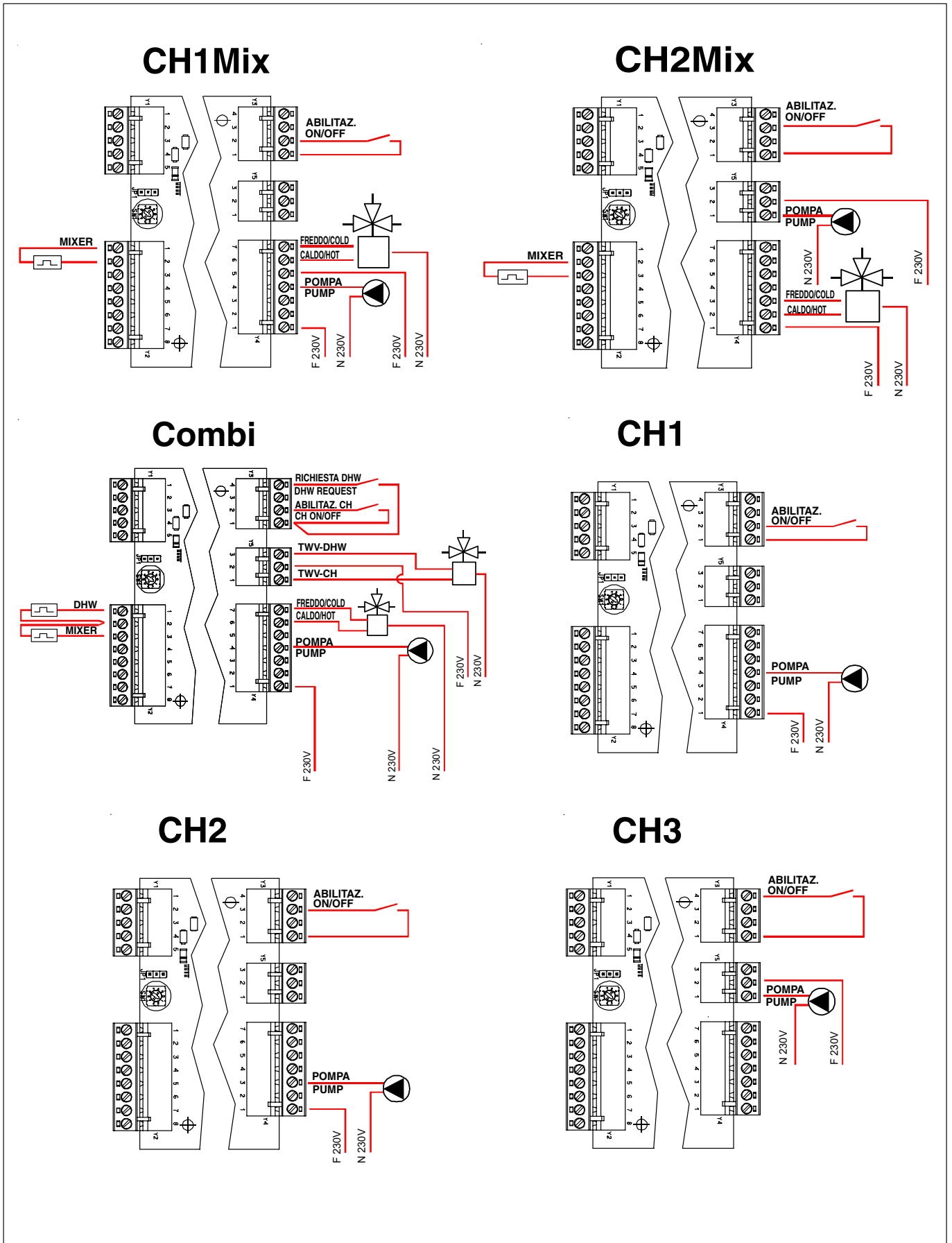

DHWS1

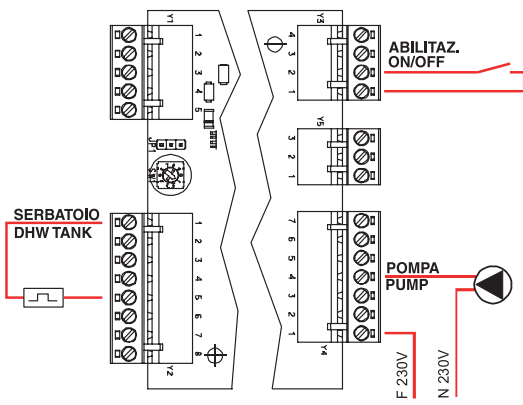

DHWS2

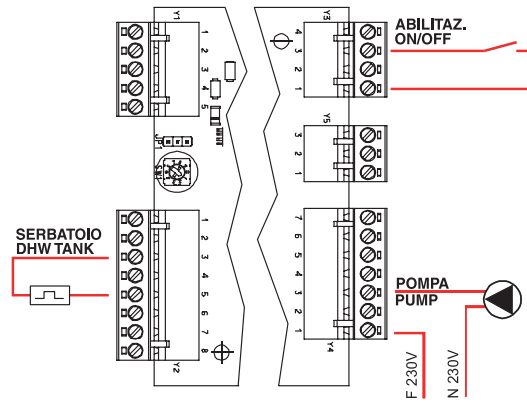

Alarm

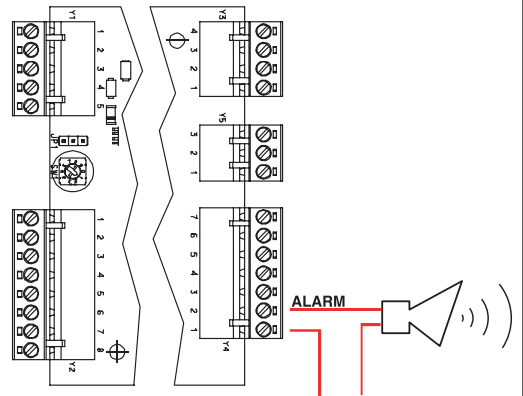

3.7 PRACTICAL SOLAR STORAGE TANK CONNECTION.

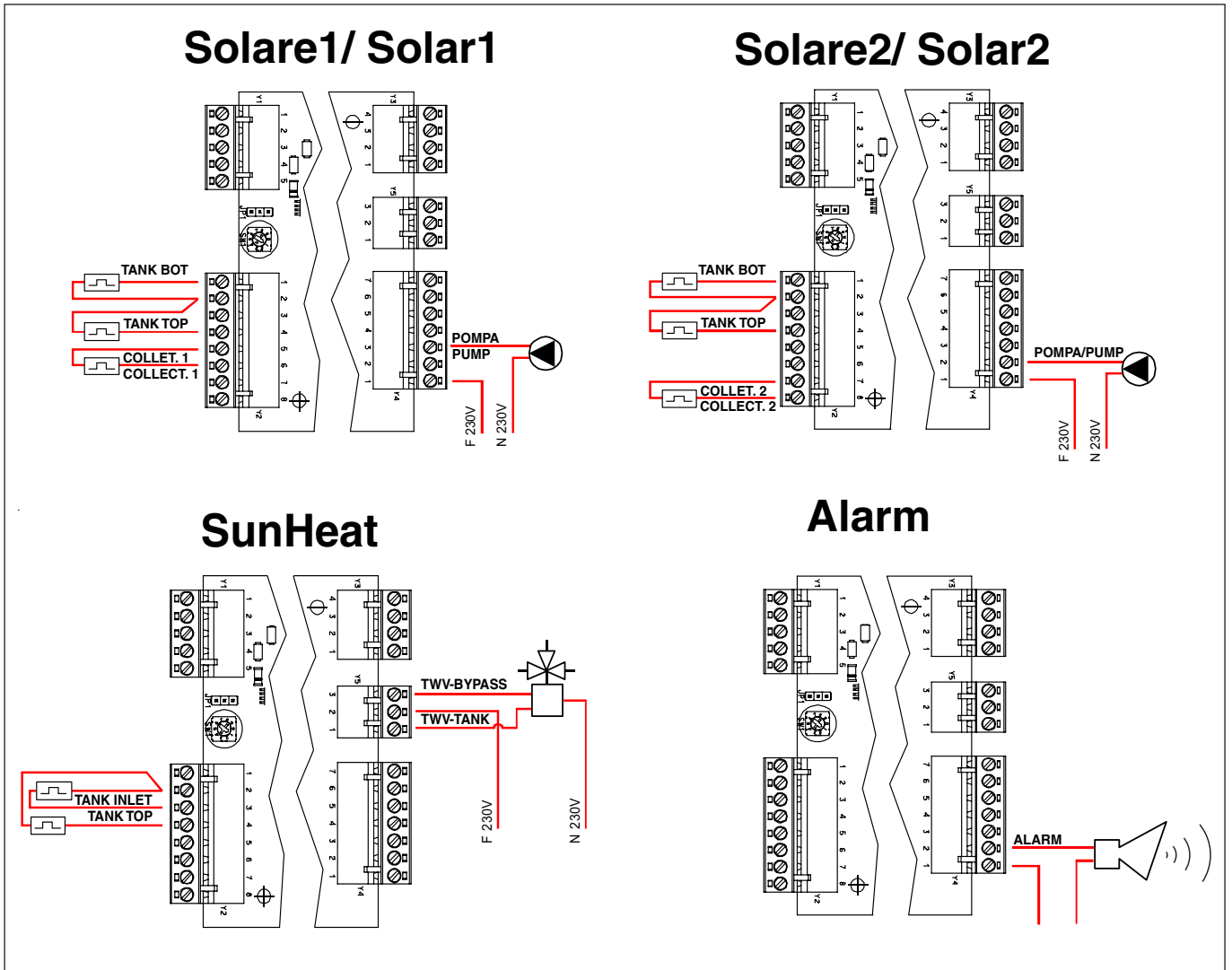

3.8 TYPES OF SYSTEM.

Parameter St selects the services supplied by the multi-function module to adapt it to the system requirements (See Installation examples):

St	CH1 Mix	CH2 Mix	DHW Mix	Combi	CH Valve	CH1	CH2	CH3	DHWS	DHWS Mix	Alarm
0	X	X									
1		X	X								
2			X		X		X				
3				X	X		X				
4					X	X	X	X			
5	X				X		X	X			
6	X				X		X		X		
7					X		X			X	
8		X								X	
9					X	X	X		X		
10						X	X		X		X
19	X						X		X		X

St	Solare 1	Solare 2	Sun Heat	CH1	DHWS Mix 1	DHWS	DHWS 1	DHWS 2	Alarm
11	X		X						
12	X	X	X						
13	X			X		X			
14	X	X		X		X			
15	X				X				
16	Reserved								
17									
18						X	X	X	
20	X			X		X			X

DHWMix.

The DHWMix service dispenses domestic hot water, drawing heat from a primary tank and supplying a plate heat exchanger via a mixing valve.

DHWS, DHWS [1÷2].

The DHWS service keeps the contents of a domestic hot water tank at the Setpoint temperature.

The Setpoint value also controls the service ON/OFF status.

DHWSmix, DHWSmix1.

The DHWSmix service keeps the contents of a domestic hot water tank at the Setpoint + DHD temperature and it controls a mixing valve to regulate the outlet temperature.

CH[1÷2]Mix.

The mixed circuits are controlled by the Setpoint value, by the status of the ON/OFF input and by the remote activation.

CH[1÷3].

The direct circuits are controlled by the Setpoint value and by the status of the ON/OFF input and by the remote activation.

Combi.

The COMBI service supplies CH1Mix and DHWMix simultaneously. The two services are provided alternately through the installation of a diverter valve controlled by outputs CH and DHW.

CH Valve.

The heating services may receive a request for heat via eBUS message, the CH Valve output makes it possible to enable the valve or pump of a circuit controlled by a room thermostat connected to the eBUS interface.

Alarm.

The alarm trigger is activated by every error detected by the module or by other system elements: SHC or BMM.

Solar1, Solar2.

Management of heat transfer from 1 or 2 solar collectors with a single storage tank.

SunHeat.

Controls the supply to the system of the heat stored in a primary tank. In HC mode, it is responsible for the running of the integration generator.



TEST.

Makes it possible to run a functional test of the appliance during the manufacturing process.

The TEST mode is enabled and disabled by the Modbus register.

The test functions are based on the exchange of information via the Modbus interface.

Anti-seizing.

To avoid seizing due to inactivity of the pump and valves: if the pump remains inactive for more than 24 h, an anti-seizing cycle is launched:

- Mixer: reaches the Hot position and then returns to the Cold position.
- Pump: is operated for 10"

Luminous indicators.

Two LED lamps are fitted to display some fundamental information; they are designed mostly for assistance and support activities.

Colour	Status	Description
Red	ON FLASHING OFF	A fault was detected Frost protection or CH frost protection Normal operation
Green	ON FLASHING OFF	Operation in CH or CH frost protection mode Operation in DHW or frost protection mode Standby

3.9 OPERATING CHECK.

The multi-function module is not fitted with a timer; the operation of each service must be controlled by an external device, connected to one of the data communication interfaces.

The HSCP control panel can perform this function via the eBUS interface.

Every active service can request a different primary temperature to meet its specific requirements; the multi-function module selects the highest request and the operating status (CH or DHW) and sends these to the heat generator control device (HCM).

In the simplest applications, featuring a single generator only, the function of HCM can be performed by a multi-function module.

3.10 HEATING.

A total of 3 direct and mixed circuits or 2 circuits - both mixed - can be managed.

3.11 DOMESTIC HOT WATER.

Systems with both a DHW storage tank and a primary storage tank and instant hot water production via plate heat exchanger can be created:

- DHWS: DHW storage tank, heat pump or diverter valve.
- DHWSmix: DHW storage tank, heat pump and 3-way mixing valve.
- DHWmix: primary storage tank, 3-way mixing valve and booster pump for plate heat exchanger.
- Combi: primary storage tank, 3-way mixing valve, booster pump and diverter valve to select: DHW plate heat exchanger - CH2Mix heating circuit.

3.12 SOLAR.

The solar storage tank management algorithm uses 2 temperature sensors: storage tank and collector, to control the transfer pump.

A further sensor controls the supplementary heating.



4 DATA COMMUNICATION.

2 separate communication channels are available, for the following application:

Local eBUS interface:

Enables communication with the data acquisition and control devices installed in the appliance or in some way served by it:

- HSCP: Control panel.
- BCM: cascade heat generators manager.
- BMM: single heat generator manager.

Remote interface:

A Modbus interface enables communication with the control system of a higher hierarchical level:

- PC.
- commercial PLC.
- Commercial Gateway for Lonworks bus.
- ...

5 PARAMETERS.

Proceed as follows to access the list of parameters:

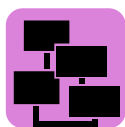

ATTENTION!

This function is explained in chapter (Device management) of the HSCP installation and maintenance manual.

Parameter **St (309)** selects the services supplied (see para. - Types of system).

Parameter **Srv (803)** makes it possible to enable only the services actually used.

The **Srv** code is obtained by adding together the codes of the desired services.

	CH1 CH1 Mix	CH2 CH2 Mix	CH3 CH3 Mix	DHW DHWS Mix	SUN
Srv	1	2	4	8	128

Example 1 (St 1)

system consisting of:

- circuit CH2 mix (value 2)
- circuit DHW mix (value 8)
- sum = 10

Example 2 (St 14)

system consisting of:

- SOLAR circuit (value 128)
- DHWS circuit (value 8)
- CH1 circuit (value 1)
- sum = 137

Once the St and Srv values have been entered disconnect and then connect the power supply to render effective the change.

The Srv parameter is updated automatically for the services equipped with sensors: the temperature sensors detected during ignition enable the correlated services.

The services which do not need the sensors are enabled by default. The „Enabling“ service inputs are enabled automatically when the corresponding input is detected as active (closed contact)



PARAMETERS

Below is a list of the configurable parameters relating to the services actually used, grouped together by type of service

"CH" Service					
Parameter	Parameter index			M.U.	Description
	CH1	CH2	CH3		
HL 1÷3	31	32	33	°C	Minimum Setpoint
HH 1÷3	39	40	41	°C	Maximum Setpoint
Po	322	322	322	min	Pumps post-circulation time
Ch Po 1÷3	64	65	66		Enabling simultaneous DHW/CH supply
POT	611	611	611	°C	Max error generator regulation in parallel supply
POL	612	612	612	%	Generator modulation limit which enables parallel supply

"CH Mix" Service				
Parameter	Parameter index		M.U.	Description
	CH1 Mix	CH2 Mix		
HL 1÷2	31	32	°C	Minimum Setpoint
HH 1÷2	39	40	°C	Maximum Setpoint
Hd 1÷2	35	36	°C	Raising the temp. required from the HCM
Po	322	322	min	Pumps post-circulation time
Vt 1÷2	359	355	sec	Mixer rotation time
Vc 1÷2	361	362	step	Mixer control frequency
AP 1÷2	352	357	°C	Mixer proportional band
AD 1÷2	481	479	°C	Mixer derivative band

"DHW Mix" Service			
Parameter	Parameter index	M.U.	Description
dL	650	°C	Minimum Setpoint
dH	385	°C	Maximum Setpoint
DH d	38	°C	Raising the temp. required from the HCM
Ad 1	481	°C	Initial position of the Mixer: Ad 1 * 2%
dt	360	°C	Raising of the request if Mixer > 80%: Increase = (Mixer - 80%)*dt/15
dr	773	°C	Enables the circuit pre-heating: dr = 0 : OFF dr = 1 : ON
dr T	656	°C	Pre-heating restoring differential
dr H	657	°C	Pre-heating restoring hysteresis
dP t	310	min	DHW pumps post-circulation time
Vt 1	359	sec	Mixer rotation time
db T	660	°C	Max temp. required by the DHW generator
Vc 1	361	step	Mixer control frequency
AP 1	352	°C	Mixer proportional band
AD 1	481	°C	Mixer derivative band



"DHWS" Service			
Parameter	Parameter index	M.U.	Description
dL	650	°C	Minimum Setpoint
dH	385	°C	Maximum Setpoint
DH d	38	°C	Raising the temp. required from the HCM
dt	360	°C	Calculation constant of the temperature requested from the HCM: dt = 0 : 85°C dt > 0 : see functional specification
dr	773	°C	Enables the circuit pre-heating: dr = 0 : OFF dr = 1 : ON
dr T	656	°C	Pre-heating restoring differential
dr H	657	°C	Pre-heating restoring hysteresis
dP t	310	min	DHW pumps post-circulation time
db T	660	°C	Max temp. required by the DHW generator

"Solar" Service			
Parameter	Parameter index	M.U.	Description
SSB	1322	°C	Minimum temperature of collectors
STT	1312	°C	Maximum temperature of collectors
ST d	1316	°C	Minimum Collector/Storage tank differential for pump activation
SH d	1317	°C	Pump activation temperature hysteresis
SK t	1323	sec	Kick pulse duration
SK d	1324	min	Interval between Kick pulses
SK s	657	min	Temperature monitoring time after one Kick
HL 1	31	°C	Temperature requested from the HCM by the frost protection

"SunHeat" Service			
Parameter	Parameter index	M.U.	Description
SRT d	1318	°C	Minimum Storage tank/Return differential for diverter valve activation
SRT h	1319	°C	Diverter activation temperature hysteresis
dT R	1320	°C	Minimum Storage tank/Request differential for integration generator activation
dT H	1321	°C	Activation temperature hysteresis for integration generator



6 STRUCTURE OF THE SYSTEM.

The circuits managed by the multi-function module: mixed CH, direct CH and DHW perform their activities independently: they supply the heat required to the system and generate a corresponding heat request to the generator.

Parameter **St** selects the services supplied by the multi-function module, parameter **Srv** enables the services actually installed.

The SHC is logically structured by the combination of functional elements, each one assigned the performance of a specific task: every service is created by combining in a chain of control one element from the following functional groups:

1. **Users:** these are services which require heat: direct and mixed CH circuits, DHW storage tank.
2. **Regulators:** these receive the request from a user and calculate the necessary flow temperature to satisfy it, while at the same time calculating the temperature request from the heat generator.
3. **Actuators:** these receive the flow temperature calculated by the regulators and control the outputs of the SHC to reach the objective.
4. **Generators:** these receive whichever is the highest temperature request from the regulators and they are called upon to supply the necessary heat.

6.1 OPERATING MODES.

The multi-function module recognises several heat requests and defines the appropriate behaviour.

The operating mode defines a specific behaviour for the outputs and an appropriate temperature regulation value.

The modes are listed in order of priority.

In the case of simultaneous requests, the one with the highest priority will be satisfied:

Priority	Mode
1 (highest)	DHW
2	DHW frost protection
3	CH
4	CH frost protection
5	TEST
6 (lowest)	STANDBY

6.2 SIMULTANEOUS CH AND DHW SUPPLY.

The simultaneous supply of CH and DHW is authorised during DHW mode if the temperature requested by the generator is reached, and the residual output is higher than a predefined limit (modulation < POL).

This simultaneous operation is inhibited again if the generator is no longer able to maintain the requested temperature.

If **POT** > 0 Demand - Effective > **POT** °C
 If **POT** = 0 Demand - Effective DHW



7.1 POWER SUPPLY.

The multi-function module does not power the bus.

7.2 COMMUNICATION BETWEEN THE HC AND THE SHCS.

The multi-function module in HC mode can receive requests from a maximum of 4 SHCs via the eBUS communication interface.

Identification of Slaves

Every slave signals its existence and its requests by broadcasting the eBUS message. If a slave interrupts the broadcast for more than 60", it is considered as not being connected and its previous requests are set to zero.

Control of Slaves

Every 10" the master broadcasts the eBUS message to inform slaves of the temperatures and operating status of the heat generator. The targets of the slaves (eBUS) are collected and used to select the operating mode of the heat generator.

7.3 MULTI-FUNCTION MODULE COMMUNICATION.

The multi-function module cyclically broadcasts its heat request and operating status to the HC of the system, which sends it the operating status of the heat generator.

It also receives the target temperatures of the services installed from the system controller.

8 INSTALLATION EXAMPLES.

Diagram with 2 low temperature zones.
 Parameter St (cod. 309) = 0.

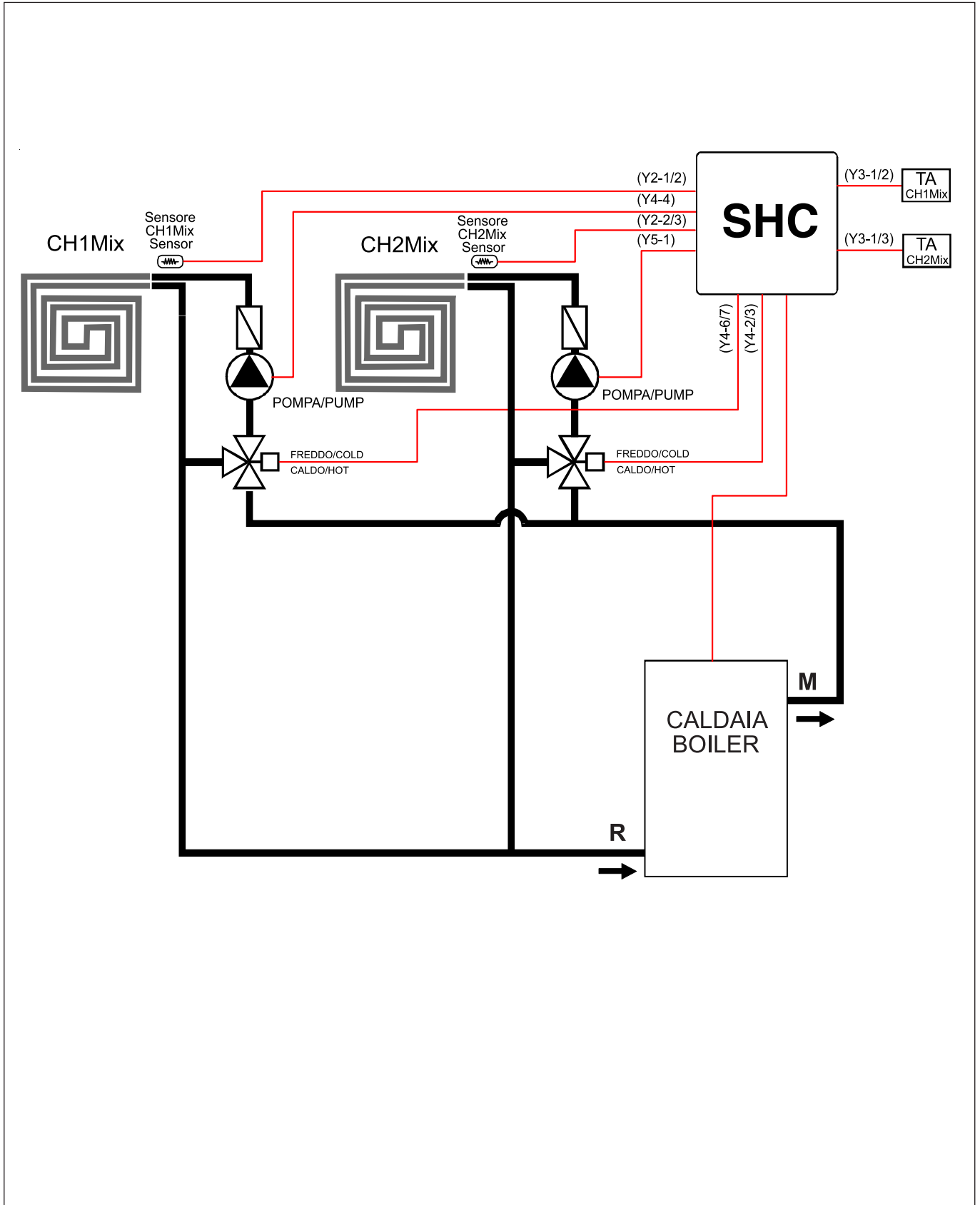

INSTALLATION EXAMPLES

Diagram with 1 low temperature zone and 1 plate heat exchanger for mixed domestic hot water.

Parameter St (cod. 309) = 1.

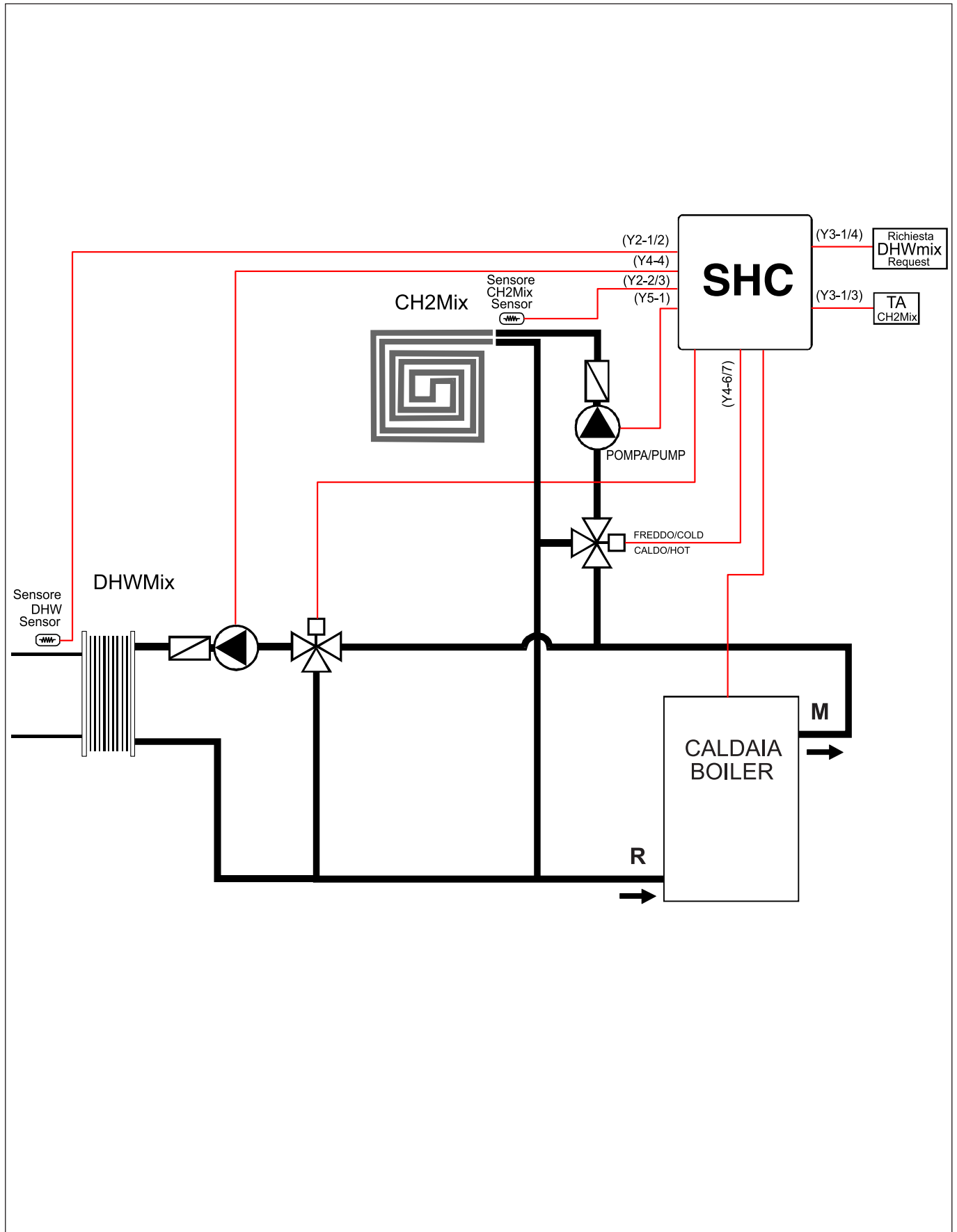
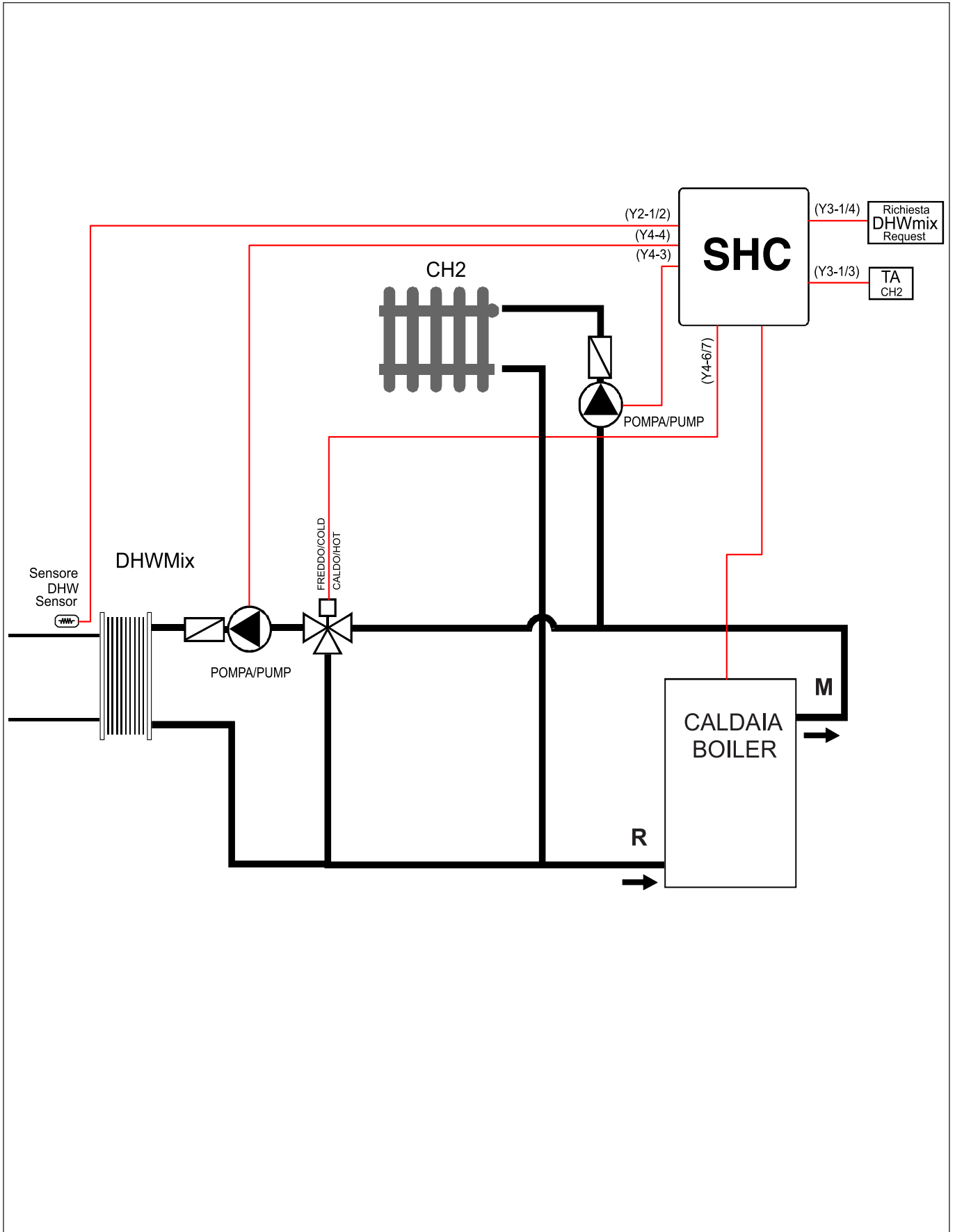

Diagram with 1 plate heat exchanger for mixed domestic hot water
and 1 high temperature zone
Parameter St (cod. 309) = 2.



INSTALLATION EXAMPLES

Diagram with Combi (1 low temperature zone and 1 plate heat exchanger for mixed domestic hot water) and 1 high temperature zone.
Parameter St (cod. 309) = 3.

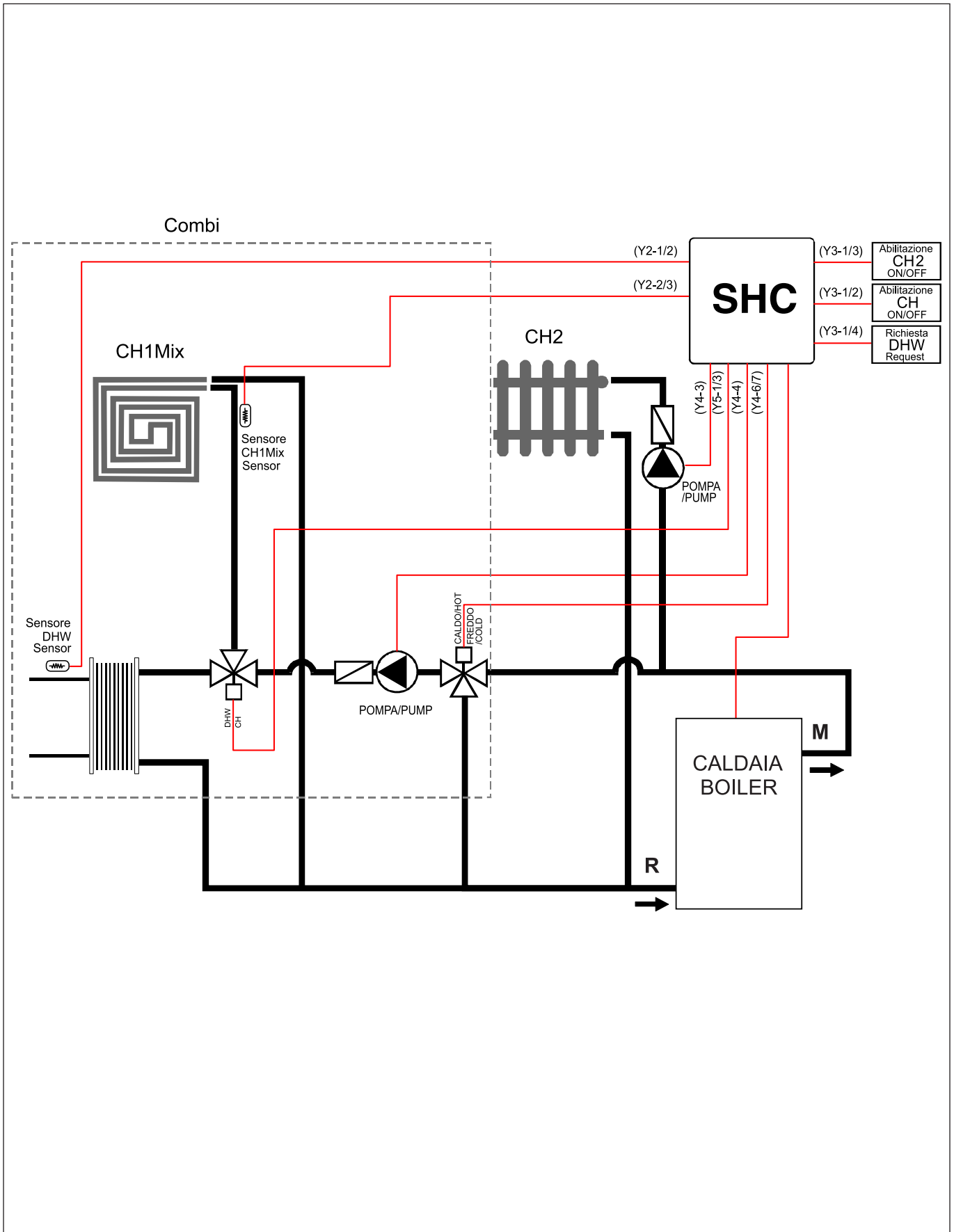
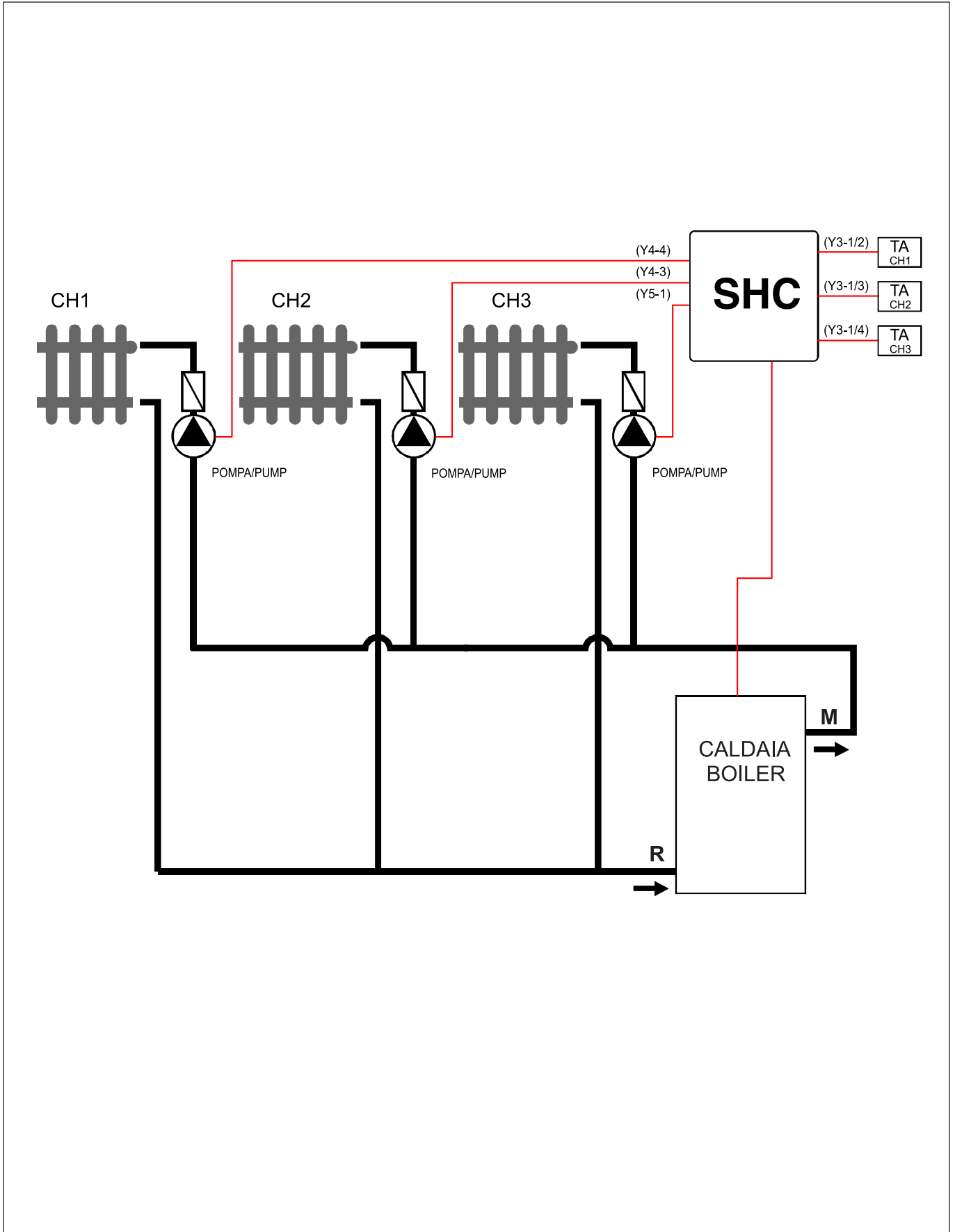

Diagram with 3 high temperature zones.
 Parameter St (cod. 309) = 4.



INSTALLATION EXAMPLES

Diagram with 2 high temperature zones and 1 low temperature zone
Parameter St (cod. 309) = 5.

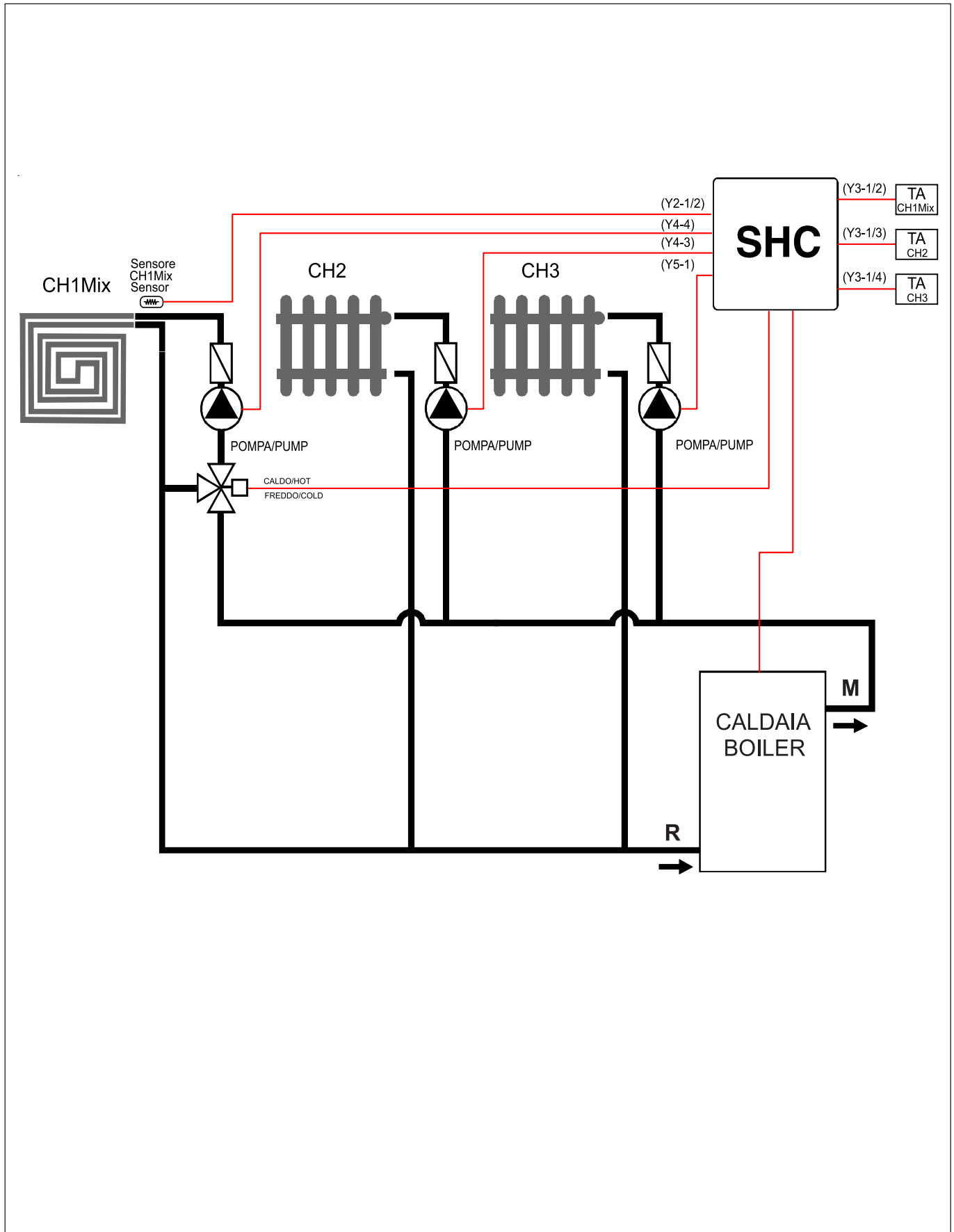
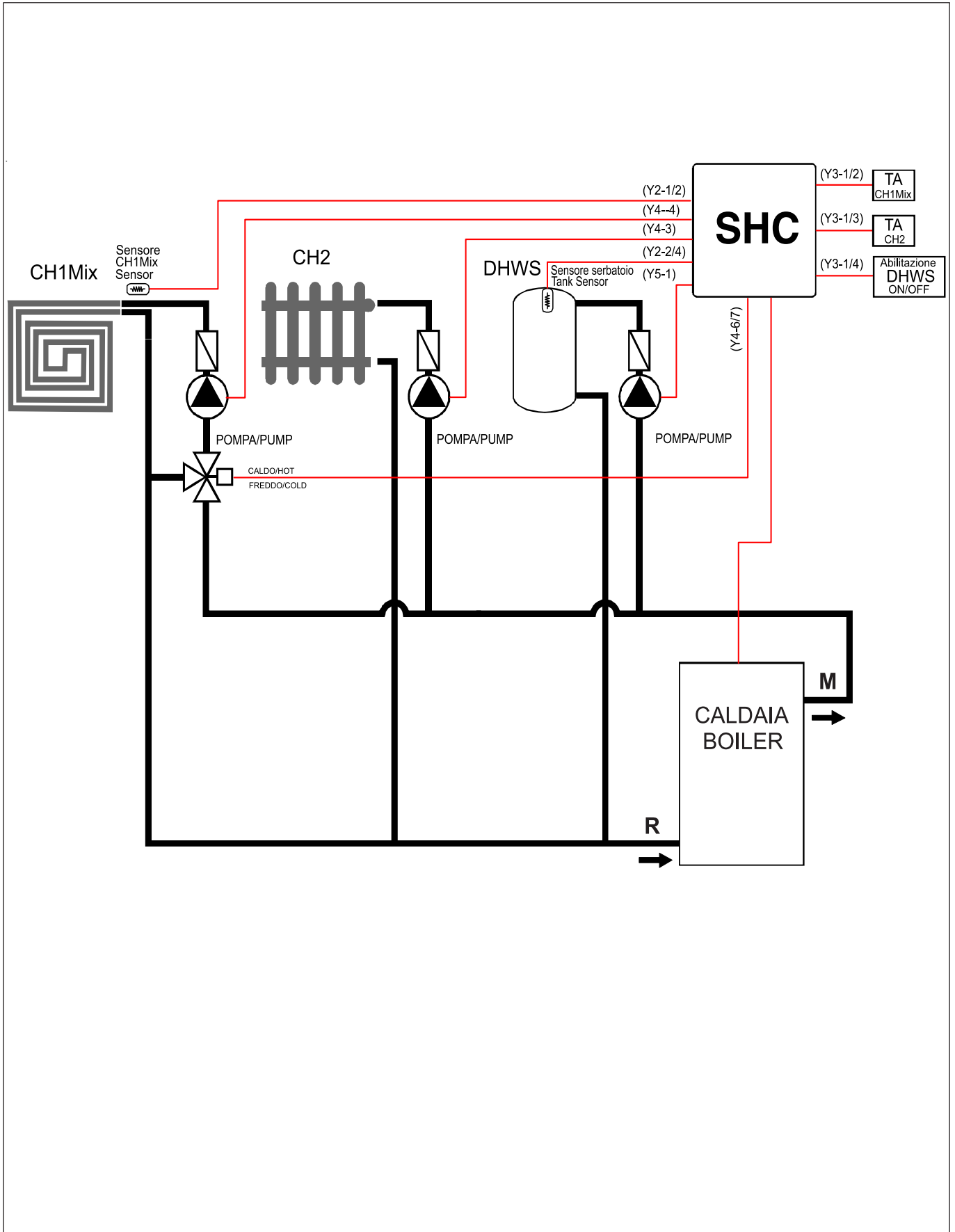

Diagram with 1 high temperature zone, 1 low temperature zone and 1 domestic hot water tank.
 Parameter St (cod. 309) = 6.



INSTALLATION EXAMPLES

Diagram with 1 high temperature zone and 1 mixed domestic hot water tank.

Parameter St (cod. 309) = 7.

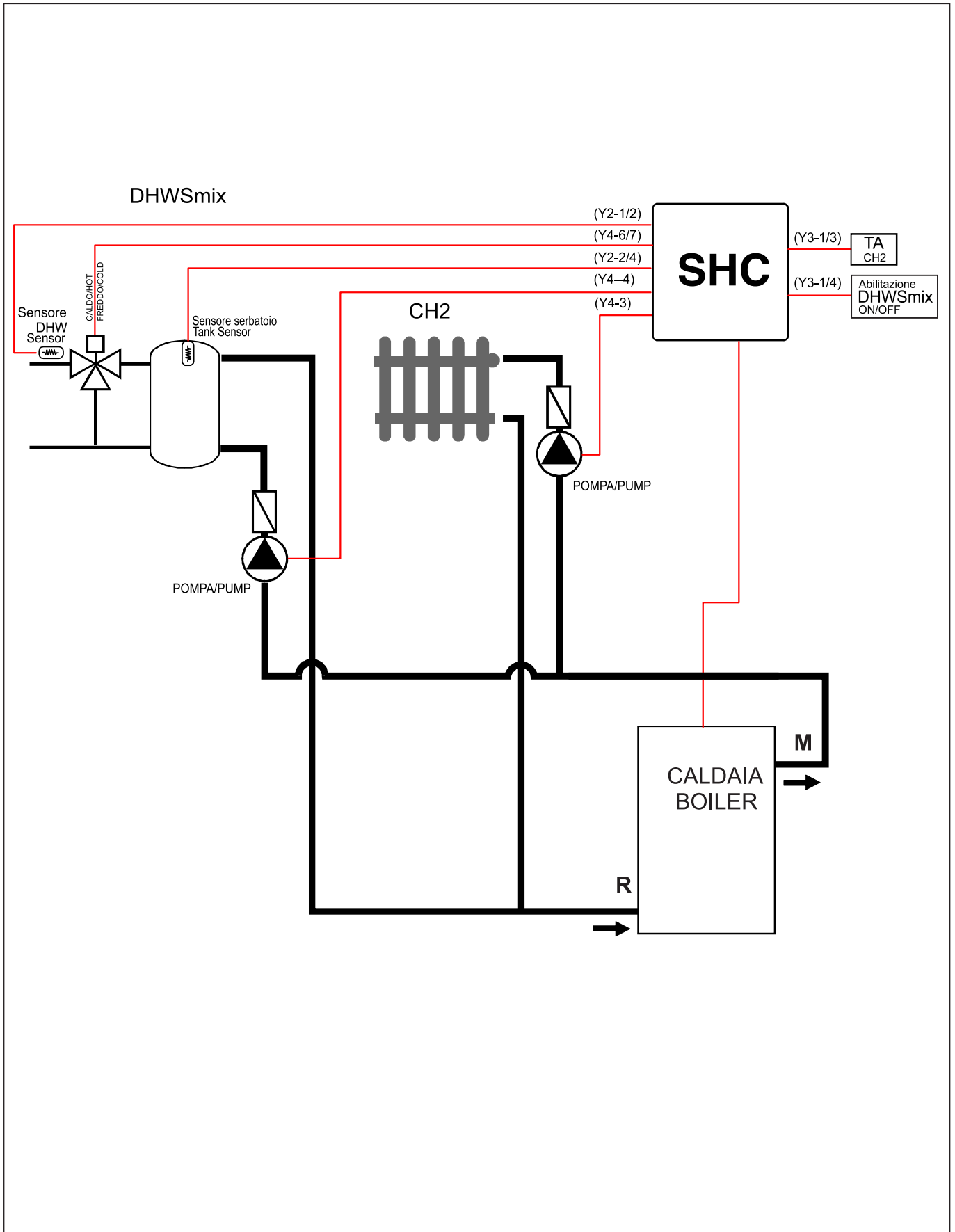
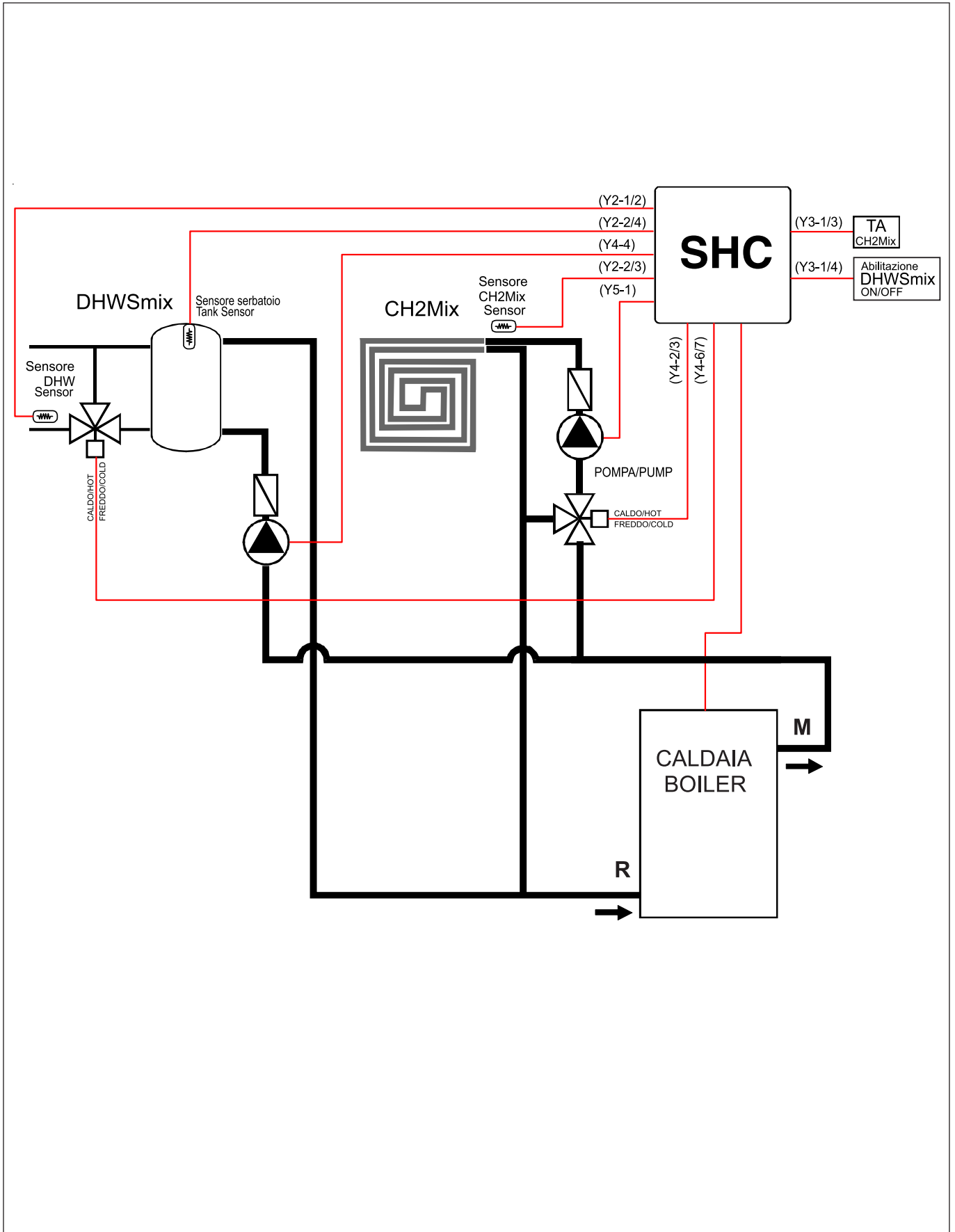

Diagram with 1 low temperature zone and 1 mixed domestic hot water tank.

Parameter St (cod. 309) = 8.



INSTALLATION EXAMPLES

Diagram with 2 high temperature zones and 1 domestic hot water tank.

Parameter St (cod. 309) = 9.

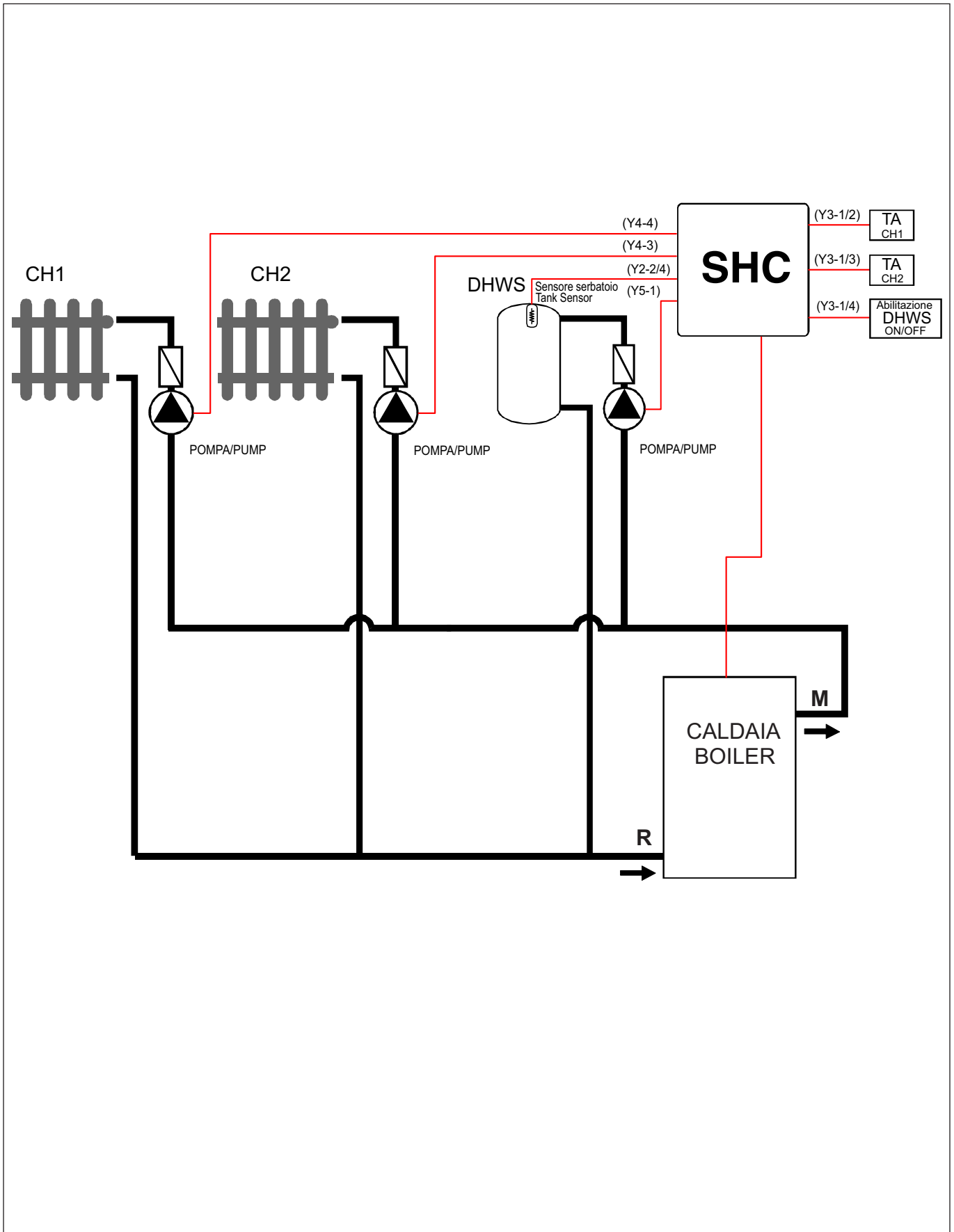
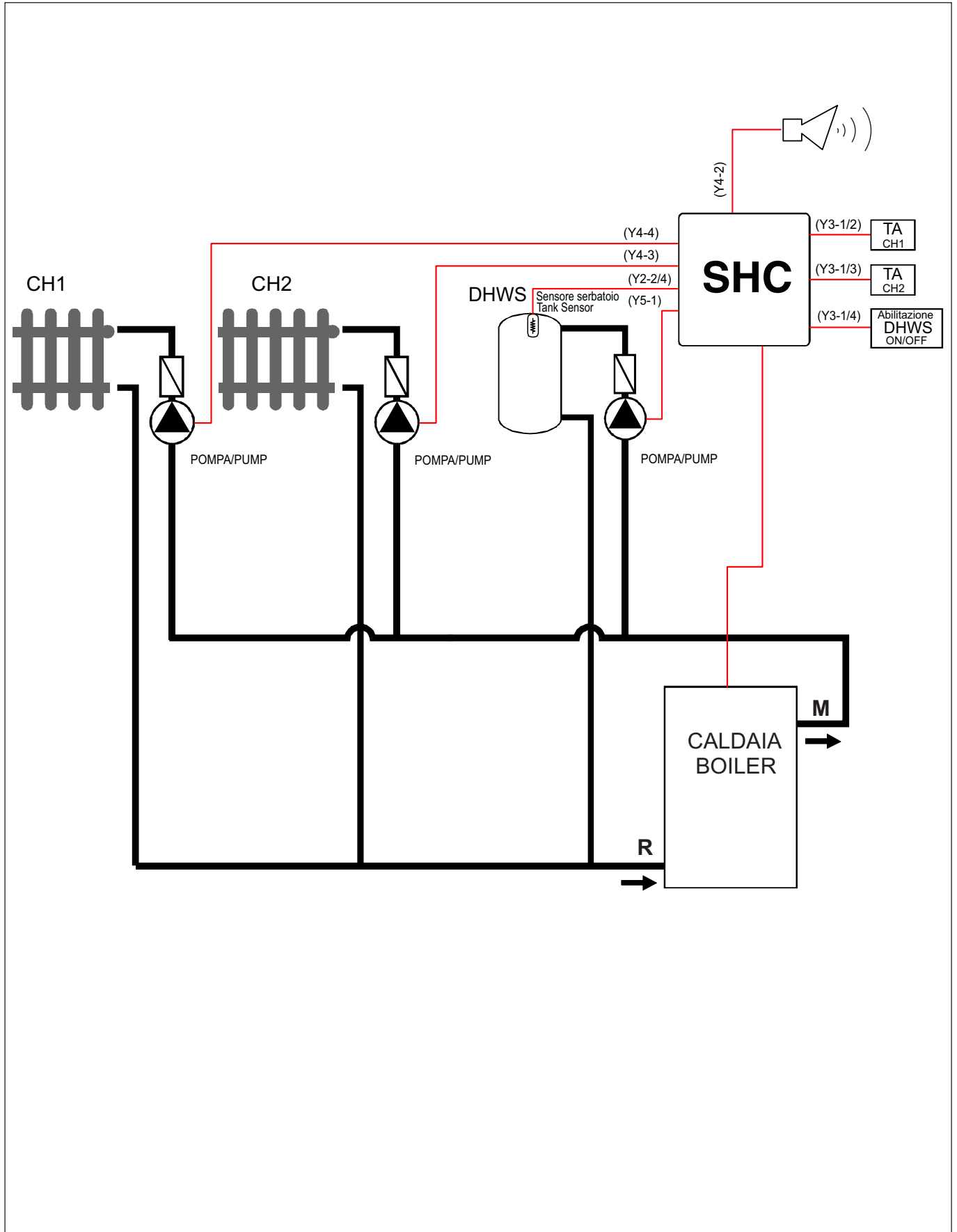

Diagram with 2 high temperature zones, 1 domestic hot water tank and 1 alarm.

Parameter St (cod. 309) = 10.



INSTALLATION EXAMPLES

Diagram with 1 solar collector with storage tank and 1 system to control the heat stored in a primary tank.
Parameter St (cod. 309) = 11.

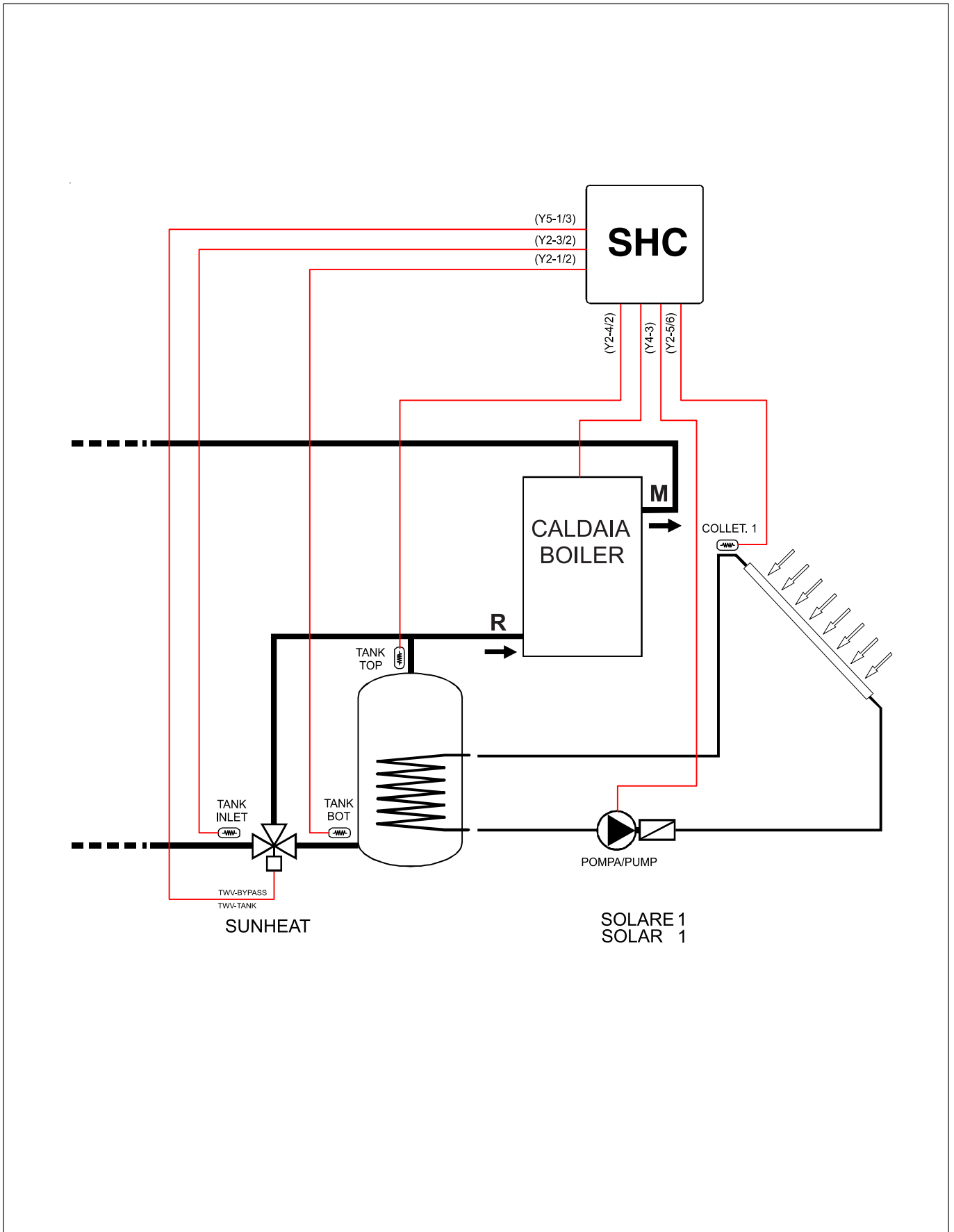
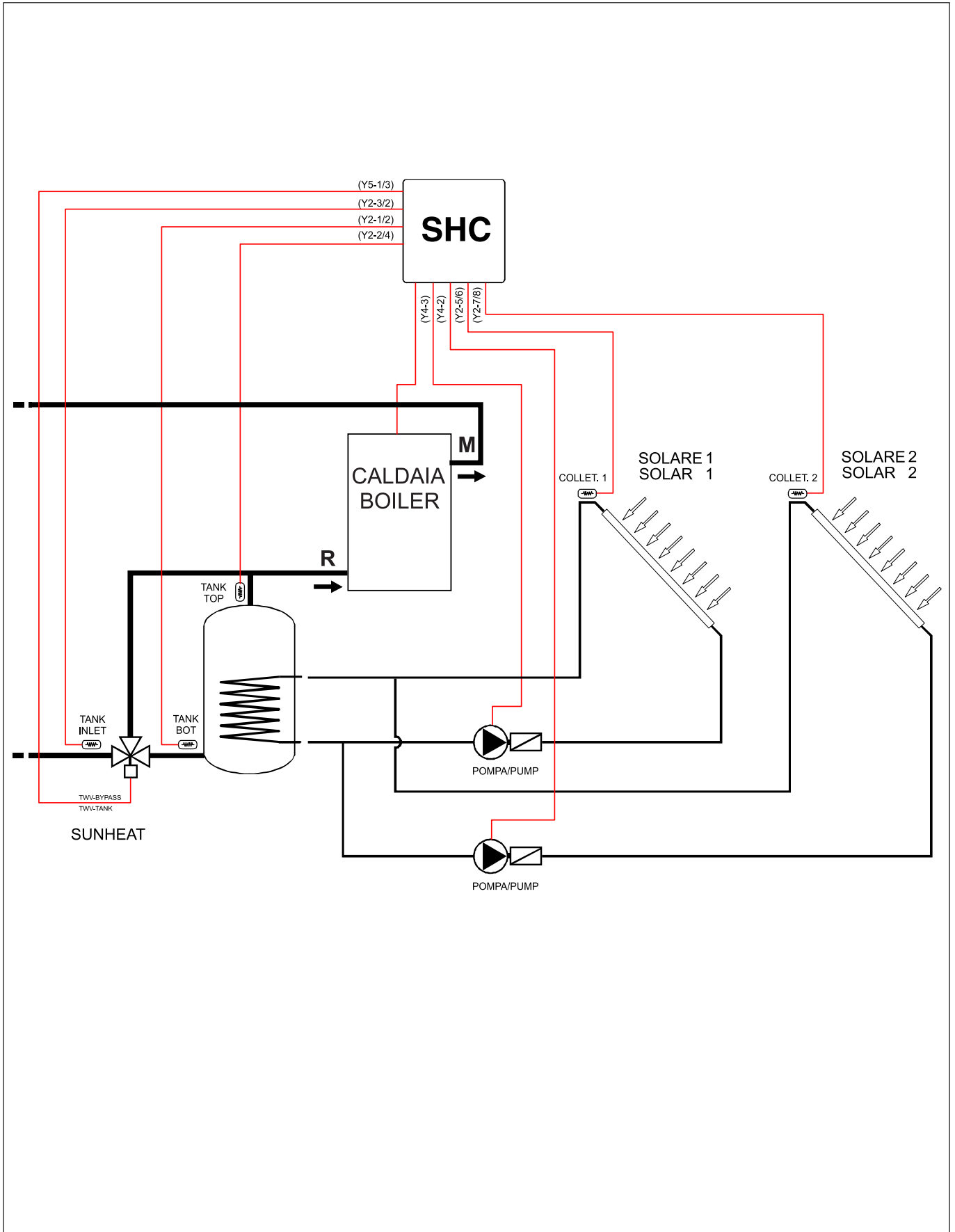

Diagram with 2 solar collectors with storage tank and 1 system to control the heat stored in a primary tank.
 Parameter St (cod. 309) = 12.



INSTALLATION EXAMPLES

Diagram with 1 solar collector with storage tank, 1 high temperature zone and 1 domestic hot water tank.
 Parameter St (cod. 309) = 13.

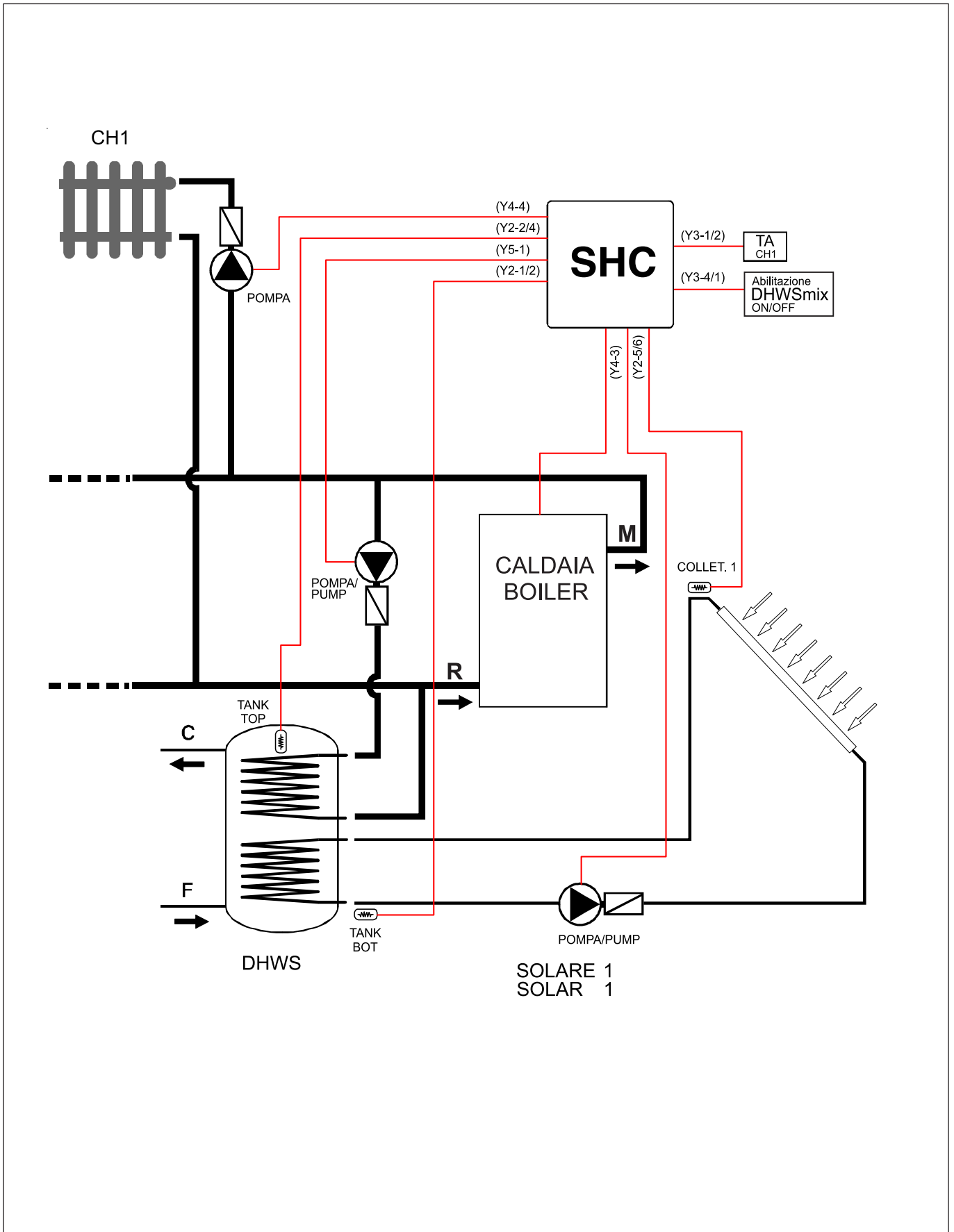

Diagram with 2 solar collectors with storage tank, 1 high temperature zone and 1 domestic hot water tank.
 Parameter St (cod. 309) = 14.

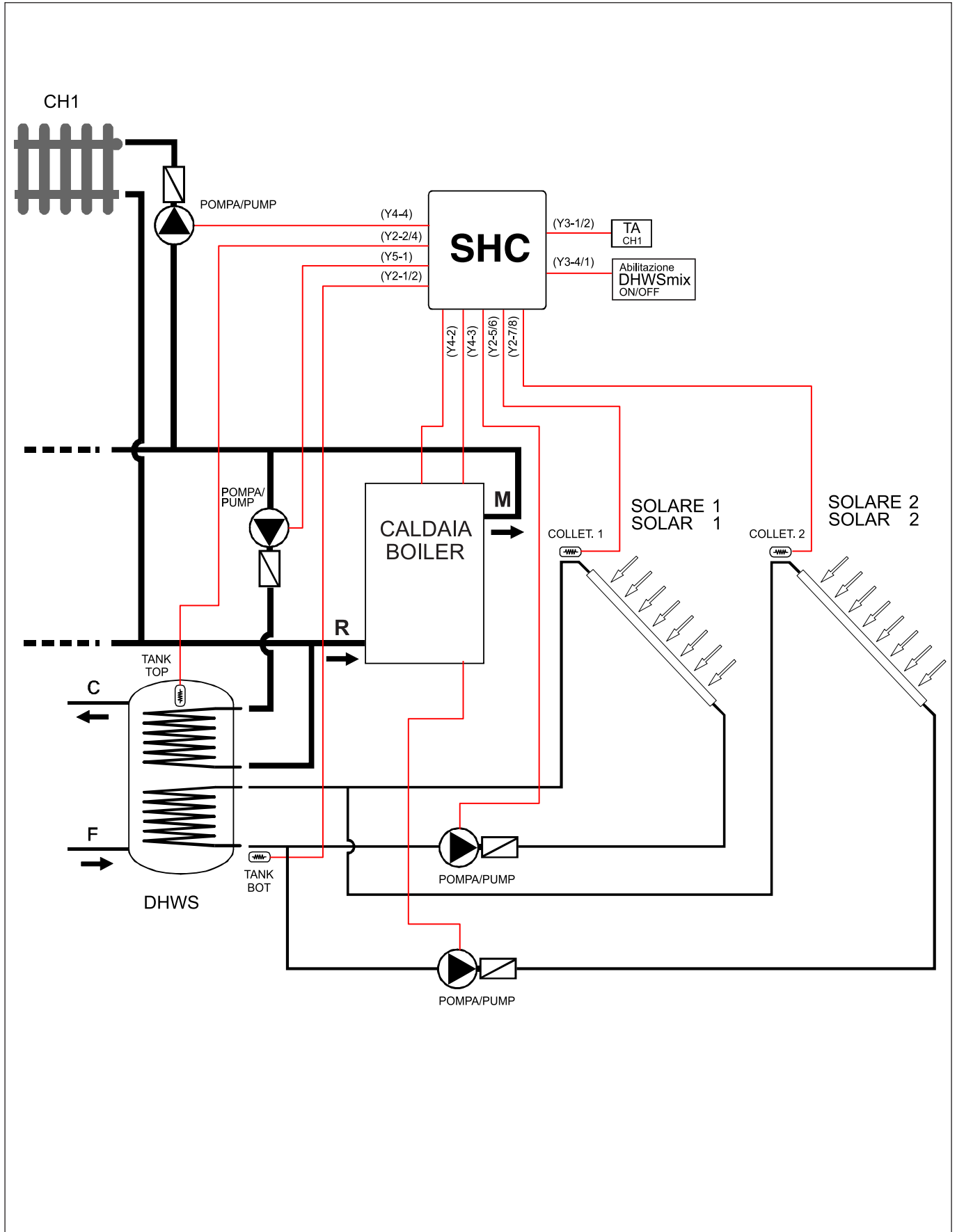
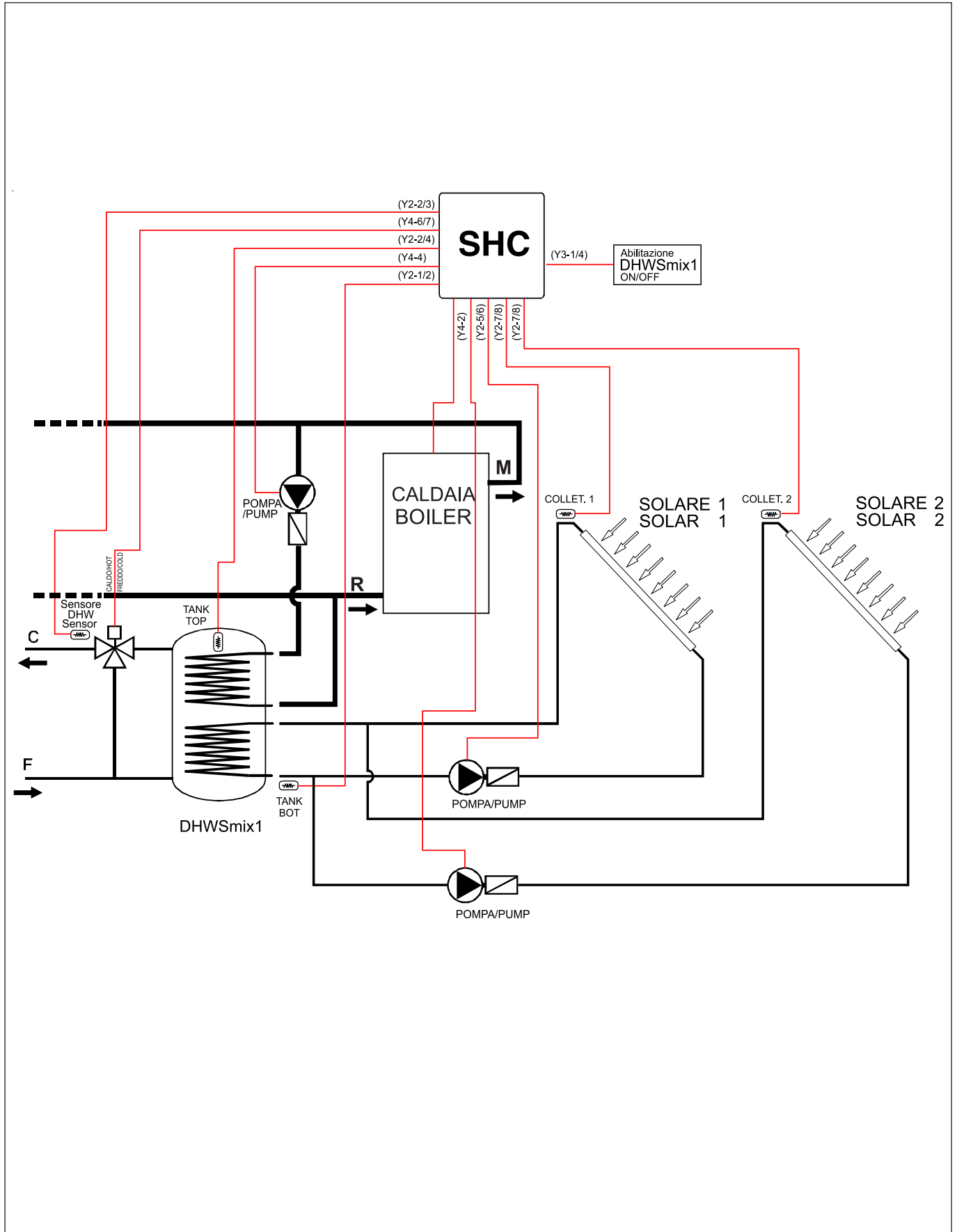

Diagram with 2 solar collectors with storage tank and 1 mixed domestic hot water tank.
 Parameter St (cod. 309) = 16.



INSTALLATION EXAMPLES

Diagram with 3 domestic hot water tanks.
 Parameter St (cod. 309) = 18.

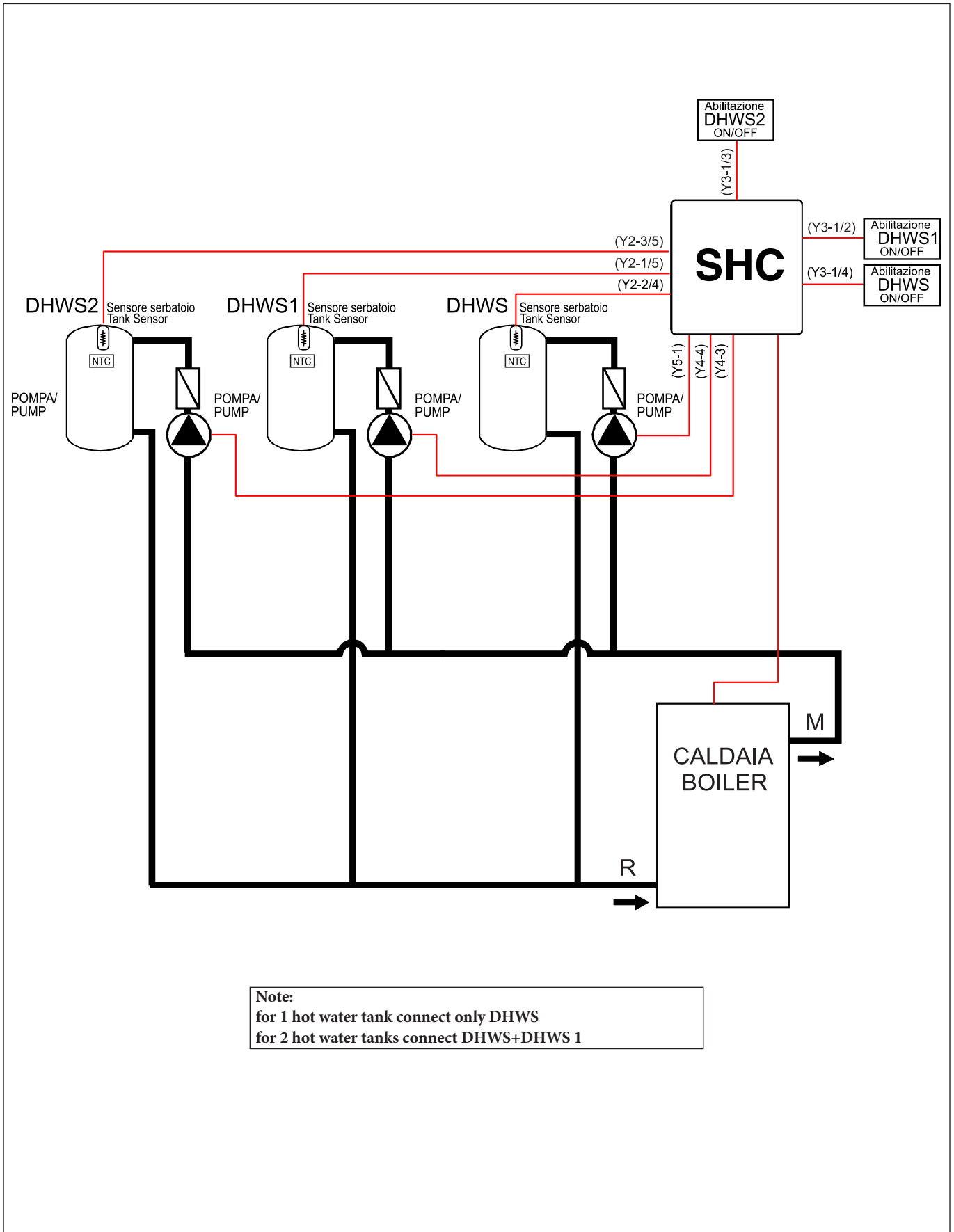
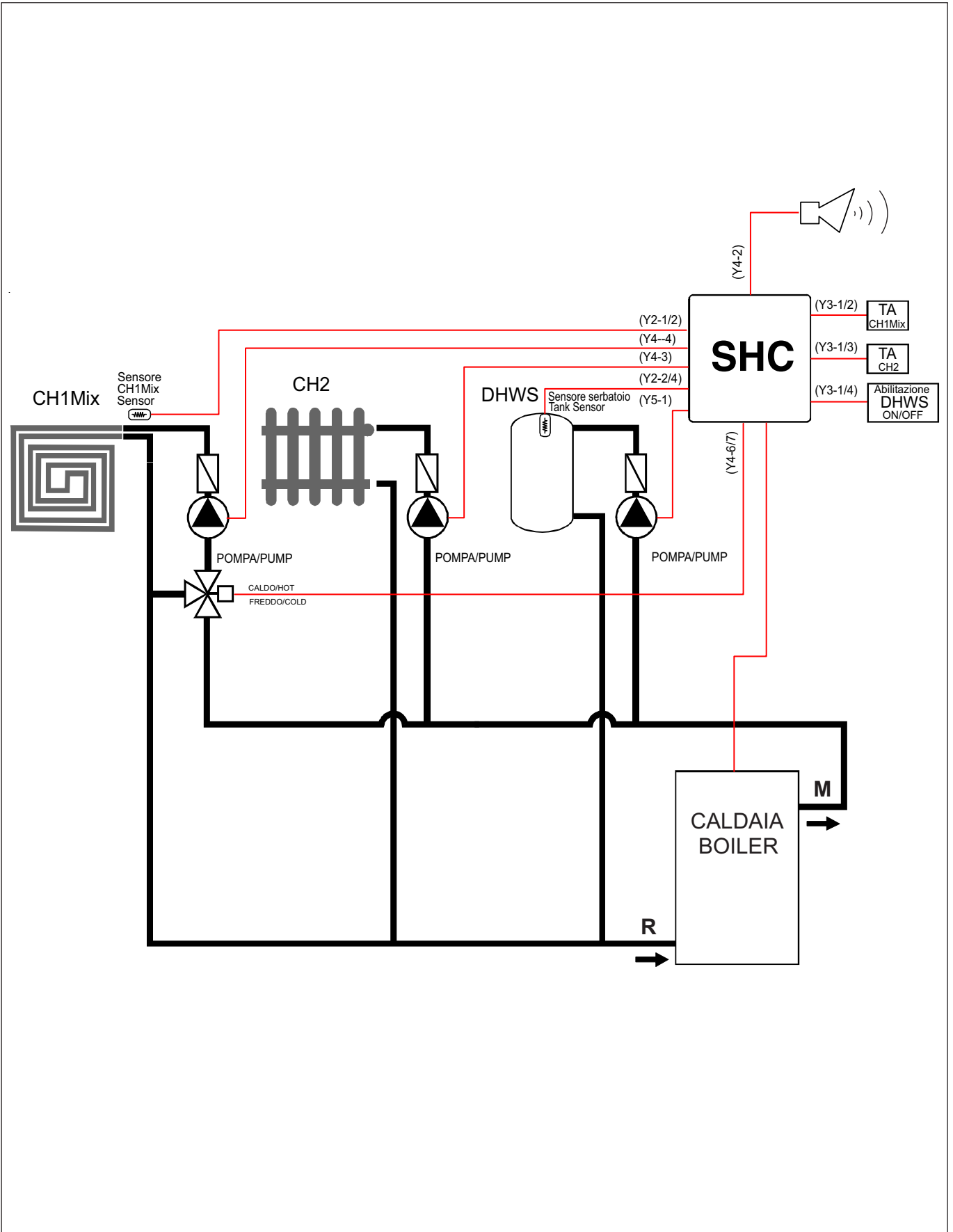

Diagram with 1 high temperature zone, 1 low temperature zone, 1 domestic hot water tank and 1 alarm.
 Parameter St (cod. 309) = 19.



9 DIAGNOSTICS.

Failures are detected by the sensors normally used for the control functions, by safety devices or logical deduction.

Each failure is distinguished by a priority level: when several failures are recognised concurrently, the one with the highest priority is signalled.

The failure code can be read using the following messages: Modbus and eBUS.

Group 1: solar storage tank alarms

Priority 1	Code 82
<p>Description: Overheating of the Solar 1 collector.</p> <p>Effect: The collector pump is disabled.</p>	
Priority 2	Code 83
<p>Description: Overheating of the Solar 2 collector.</p> <p>Effect: The collector pump is disabled.</p>	
Priority 3	Code 84
<p>Description: Freezing of the Solar 1 collector.</p> <p>Effect: The collector pump is kept ON for the time selected by Sft.</p>	
Priority 4	Code 89
<p>Description: Overheating of the solar storage tank.</p> <p>Effect: The collector pump is disabled.</p>	
Priority 5	Code 85
<p>Description: Freezing of the Solar 2 collector.</p> <p>Effect: The collector pump is kept ON for the time selected by Sft.</p>	



DIAGNOSTICS

Priority 6	Code 34
<p>Description: Freezing of flow CH2 Mix: it is detected if NTC 2 < 2°C and disabled when NTC 2 > 5°C.</p> <p>Effect: The mixer is regulated to the "Hot" position and the pump is enabled to obtain heat from the system; if the problem persists for more than 5', all the outputs are disabled.</p>	
Priority 7	Code 33
<p>Description: Freezing of flow CH1 Mix: it is detected if NTC 1 < 2°C and disabled when NTC 1 > 5°C.</p> <p>Effect: The mixer is regulated to the "Hot" position and the pump is enabled to obtain heat from the system; if the problem persists for more than 5', all the outputs are disabled.</p>	
Priority 8	Code 8
<p>Description: Protection input triggered.</p> <p>Effect: The burner and the pump are disabled.</p>	
Priority 9	Code 16
<p>Description: Freezing of the heat exchanger: it is detected if NTC 1 < 2°C, and disabled when NTC 1 > 5°C.</p> <p>Effect: The burner is disabled, the pump is enabled for 5' in an attempt to draw heat from the system.</p>	
Priority 10	Code 6
<p>Description: Freezing of the heat exchanger: it is detected if NTC 1 > 95°C, and disabled when NTC 1 < 80°C.</p> <p>Effect: The burner is disabled and the pump enabled.</p>	



Priority 11	Code 13
<p>Description: NTC 3: interrupted or short-circuited.</p> <p>Effect: The activities of the services using this sensor are suspended.</p>	
Priority 12	Code 54
<p>Description: MIXER 2: interrupted or short-circuited (NTC 2).</p> <p>Effect: The activities of the services using this sensor are suspended.</p>	
Priority 13	Code 53
<p>Description: MIXER 1: interrupted or short-circuited (NTC 1).</p> <p>Effect: The activities of the services using this sensor are suspended.</p>	
Priority 14	Code 81
<p>Description: PTC 2: interrupted or short-circuited.</p> <p>Effect: The activities of the Solar 2 service are suspended.</p>	
Priority 15	Code 80
<p>Description: PTC 1: interrupted or short-circuited.</p> <p>Effect: The activities of the Solar 1 service are suspended.</p>	
Priority 16	Code 70
<p>Description: NTC 3: DHWS storage tank: interrupted or short-circuited (NTC 3).</p> <p>Effect: The activities of the services using this sensor are suspended.</p>	
Priority 17	Code 71
<p>Description: DHWS 1 or DHW-Combi storage tank: interrupted or short-circuited (NTC 1).</p> <p>Effect: The activities of the services using this sensor are suspended.</p>	
Priority 18	Code 72
<p>Description: DHWS 2 or DHWS-Combi storage tank: interrupted or short-circuited (NTC 2).</p> <p>Effect: The activities of the services using this sensor are suspended.</p>	



DIAGNOSTICS

Group 5: system faults.

Priority 19	Code 8
Description: Insufficient pressure of the primary water circuit.	
Effect: All services are disabled except for the management of the solar storage tanks.	
Priority 20	Code 49
Description: No master regulator has been detected: ModBus or eBUS.	
Effect: All services are disabled except for the management of the solar storage tanks.	
Priority 21	Code 30
Description: Installation parameters corrupt or invalid.	
Effect: The memory is initialised with the default values, all services are disabled except for the management of the solar storage tanks.	
Priority 22	Code 37
Description: Parameters memory faulty.	
Effect: All services are disabled.	



List of supply parameters.

Code	Symbol	Description	Value	Unit	Minimum	Maximum
309	St	Application Code	0		0	20
803	Srv	Services ON	0		0	255
816	MI	Modbus Address	2		1	127
817	MT	Modbus Timeout	0	sec	0	240
896	TU	°Fahrenheit	0		0	1
376	DI1	Input#1: Function	1		0	1
377	DI2	Input#2: Function	1		0	1
378	DI3	Input#3: Function	1		0	1
322	Po	Pumps post-circulation time	10	min	1	30
611	POT	n.d.	5	°C/°C	0	30
612	POL	CH Parallel: Max Mod	0	%	0	100
31	HL	CH: Minimum Setpoint	25,0	°C	20,0	45,0
32	HL1	CH#1: Minimum Setpoint	25,0	°C	20,0	45,0
33	HL2	CH#2: Minimum Setpoint	25,0	°C	20,0	45,0
39	HH	CH#1: Maximum Setpoint	85,0	°C	50,0	85,0
40	HH1	CH#2: Maximum Setpoint	85,0	°C	50,0	85,0
41	HH2	CH#3: Maximum Setpoint	85,0	°C	50,0	85,0
64	ChPO1	CH#1: DHW Parallel	0		0	1
65	ChPO2	CH#2: DHW Parallel	0		0	1
66	ChPO3	CH#3: DHW Parallel	0		0	1
35	Hd	CH#1: Regulation Diff.	10	°C/°C	0	20
36	Hd1	CH#2: Regulation Diff.	5	°C/°C	0	20
38	DHd	DHW: Regulation Diff.	15	°C/°C	0	30
352	Ap	Mix#1: Proportional Reg	6	°C	1	50
357	Ap1	Mix#2: Proportional Reg	25	°C	1	50
481	Ad	Mix#1: Derivative Reg.	35		0	50
479	Ad1	Mix#2: Derivative Reg.	0		0	50
359	Vt	Mix#1: Rotation Time	120	sec	30	600
361	Vc1	Mix#1: Frequency PWM	30		10	100
355	Vt1	Mix#2: Rotation Time	120	sec	30	600
362	Vc2	Mix#2: Frequency PWM	30		10	100
650	dL	DHW: Minimum Setpoint	35,0	°C	20,0	45,0
385	dH	DHW: Max. Setpoint	60,0	°C	50,0	65,0
360	dt	Storage Tank Regulation	3		0	15
656	drT	DHW: Request Temperature Differential	10	°C/°C	-20	20
657	drH	DHW: Request Temp. Hysteresis	10	°C/°C	0	20
660	dbT	Max. temperature request in DHW	80	°C	70	85
773	dr	DHW: Enable the Request Sens.	1		0	1
775	Ett	Diverter Valve: Travel Time	5	sec	0	30
310	dPt	DHW pumps post-circulation time	30	sec	0	600
1280	SST1	Solar Coll. 1: Max. Temp.	140	°C	60	180
1281	SSH1	Solar Coll. 1: Max. Hyst.	5	°C/°C	5	30
1296	SST2	Solar Coll. 2: Max. Temp.	140	°C	60	180
1297	SSH2	Solar Coll. 2: Max. Hyst.	5	°C/°C	5	30
1312	STT	Solar Storage Tank: Max. Temp.	90	°C	50	90
1313	STH	Solar Storage Tank: Max. Hyst.	5	°C/°C	5	30



DIAGNOSTICS

Code	Symbol	Description	Value	Unit	Minimum	Maximum
1314	SF	Solar Coll.: Frost Protection	0		0	1
1315	SFt	Solar Coll.: Frost Protection Time	30	sec	5	60
1316	STd	Solar Storage Tank: Load Diff.	8	°C/°C	3	30
1317	SHd	Solar Storage Tank: Load Hyst.	7	°C/°C	1	20
1318	SRTd	Solar Storage Tank: Flow rate Diff.	5	°C/°C	3	30
1319	SRTH	Solar Storage Tank: Flow rate Hyst.	5	°C/°C	1	20
1320	dTR	Solar Storage Tank: Integr. Diff	4	°C/°C	3	30
1321	dTH	Solar Storage Tank: Integr. Hyst.	8	°C/°C	1	20
1322	SSB	ON/OFF Temp. of Collectors	40	°C	1	100
1323	SKt	Kick: Time	0	sec	0	60
1324	SKd	Kick: Pause	10	min	10	60
1325	SKs	Kick: Measuring Time	1		1	5









Immergas S.p.A.

42041 Brescello (RE) - Italy

Tel. 0522.689011

immergas.com

Cod. 1.042861ENG - ST.003927/002 - 01/26



 This instruction booklet is made of ecological paper.

