

DOMINUS V2
Remote Control Application
Code 3.034903

immergas.com
Immergas S.p.A.
42041 Brescello (RE) - Italy
Tel. 0522.689011 Fax 0522.680617

Code 1.048986ENG - Rev. ST.008606/002 - 03/25

The manufacturer Immergas S.p.A., hereby declares that the "Dominus V2" radio appliance complies with directive 2014/53/EU.

For further details on the product CE marking, request a copy of the Declaration of Conformity from the manufacturer, specifying the appliance model and the language of the country.

FOREWORD.

"Dominus V2" has been designed to remotely control and regulate the specific generator operating values. Only a few minutes are required for installation: Dominus V2 is in fact connected to the Immergas generator with just 2 cables, through which it receives and sends adjustment and control commands. Power is supplied directly from the 230Vac terminals in the generator terminal block.

The "Dominus" application must be downloaded from the Apple Store (Apple) or Play Store (Android), installed on the mobile device (smartphone, tablet).

Otherwise, you can download the 'Dominus' application using the QR-code available on this installation sheet (Fig. 7 for Android App or Fig. 8 for iOS App).

After the installation and configuration, the application is ready for use thanks to the simplicity of use that distinguishes it. Depending on their needs, the customer can change or view the settings for the controlled system or generator.

GENERAL WARNINGS.

This manual was intended for: **the Installer.**

- Carefully read the warnings contained in this document as they provide indications on the technical features as well as the installation and assembly instructions.
- The device must be installed in compliance with electrical installation standards in force.
- This instruction manual and the "Dominus" application manual must be **"kept for future reference"**.
- After having removed the packaging, check the integrity of the device. If in doubt, do not use it and contact the **Dealer or Manufacturer.**
- Dominus V2 is intended only for the use for which it has been expressly designed. Any other use must be considered improper and therefore dangerous.
- Our products are manufactured in compliance with current safety standards. During installation and use, it is recommended to observe all the precautions to avoid harming persons or damaging objects.
- Do not remove parts of the appliance when it is operating.
- Do not use the Dominus V2 application in places exposed to heat sources or direct sunlight.
- The manufacturer will not be held responsible in the following cases:
 - a) Incorrect installation.
 - b) Operating defects of the generator that the device is connected to
 - c) Changes or interventions not authorised by the manufacturer.
 - d) Total or partial failure to comply with instructions.
 - e) Exceptional events etc.

N.B.: Dominus V2 must be installed less than 2 metres above the floor;

N.B.: Dominus V2 cannot be installed outdoors;

N.B.: Dominus V2 cannot be installed within 20 cm of the human body.

CLEANING THE COVER.

Use only a dry cloth to clean the cover of the Dominus V2 application. Never use abrasive or powder detergents.

WARNING.

Immergas reserves the right to make improvements and changes to details and accessories, excepting the essential features of the model described and illustrated herein.

1. INSTALLATION.

1.1 Installation recommendations.

Dominus V2, including the relative cables and connections to the generator, must be installed by specialised staff. Upon the free initial check of the generator, when the appliance is inserted into the system, the Immergas authorised after-sales centre checks the connection to the generator terminal board and adjusts operation. The free check just of the Dominus V2 application is not envisioned by the Immergas authorised after-sales centre if requested after the generator warranty has initiated.

Attention: laying the Dominus V2 cables is excluded from the free generator checks; it is the responsibility of the installer company.

1.2 Package contents.

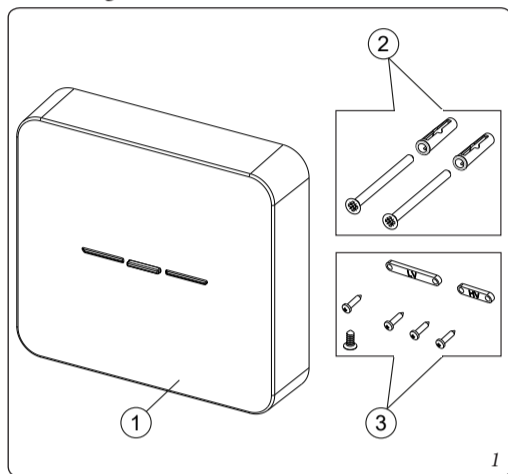

Ref	Description
1	Dominus V2
2	Kit with expansion plugs and screws for wall mounting of Dominus V2.
3	Dominus V2 kit with 4 screws, cable stop plates and closing cover screw

1.3 Electrical connection.

N.B.: make sure that the installation area of Dominus V2 properly receives the signal of the home Wi-Fi network.

N.B.: before performing any electrical connection, make sure that all the involved appliances are disconnected from the mains.

N.B.: for correct installation prepare a dedicated power line for the connection of the Dominus V2 application according to the Standards in force regarding electrical systems. If this is not possible interference due to other electric cables could cause malfunctioning of the module itself.

The electrical connections to be performed on the Dominus V2 device must be carried out according to the diagrams shown in Chapter 3.

N.B.: respect the polarity indicated in the relative diagram.

N.B.: for connection to the power supply line, provide a double-insulated electrical cable.

N.B.: if the device is not powered by an Immergas generator, Dominus V2 must be connected to a V230Vac / 50Hz mains in compliance with standards in force regarding electrical installation, which anyhow must include a class III overvoltage category omnipolar disconnection device.

Dominus V2 can be installed on the wall (Fig.2) using the plugs (Fig. 2 Ref. 1) and the screws (Fig. 2 Ref. 2) supplied with it. Next, proceed with the connection of the electrical cables and secure them with the cable ties (Fig. 2 Ref. 3) and relative screws (Fig. 2 Ref. 4) supplied with the equipment.

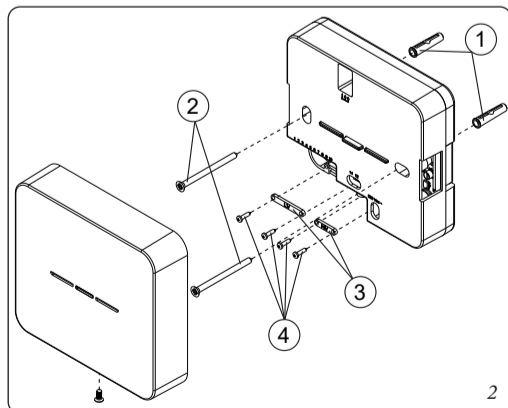

Once the electrical connection has been done, close the Dominus V2 device by fastening its protective cover (Fig. 3 Ref. 1) with the specific screw (Fig. 3 Ref. 2).

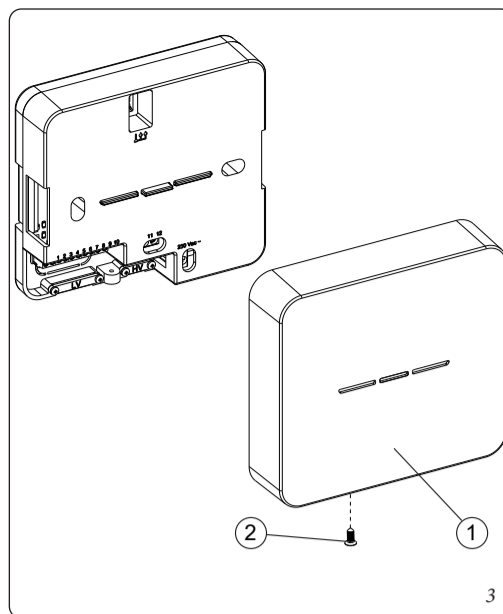

1.4 System configuration.

N.B.: the parameters of the generator must be set appropriately according to the type of generator that Dominus V2 is connected to. See Table 2.2 in this respect.

After having powered up Dominus V2, wait about 30 seconds before configuration so that communication between Dominus V2 and the generator has been established.

N.B.: upon first ignition, Dominus V2 activates in 'Access Point' mode so that it can be configured for subsequent connection to the home Wi-Fi network. In this regard, follow the instructions given in the appliance's operating manual that can be downloaded from the Dominus app.

N.B.: if the configuration procedure needs to be repeated, you can reset the appliance as described below:

- hold down the reset button (Fig. 4, Ref. 2) for at least 10 seconds;
- when the button is released, Dominus V2 resumes operation as 'Access-Point': left LED flashing green (Fig. 4, Ref. 1) and right LED flashing red (Fig. 4, Ref. 3).

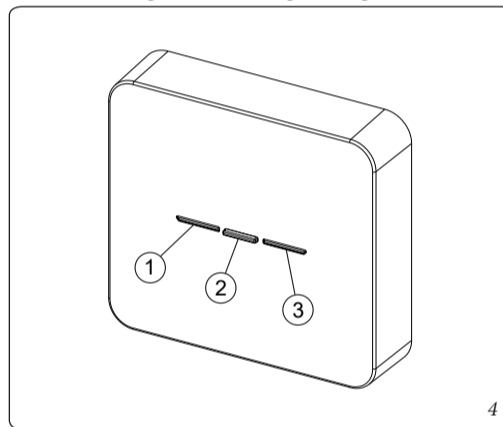

1.5 Application download and installation on mobile devices (smartphone/tablet).

Using the mobile device on which to install the application, connect to the App store of reference: App Store (Apple) or Play Store (Android) and type in "Immergas" in the search field.

Otherwise, use the QR-code on this installation sheet (Fig. 7 for Android App or Fig. 8 for iOS App).

Select the free "Dominus" application and wait for its download and installation on the mobile device used.

The app works with IOS 12 operating system or Android 10 or higher.

Open the "Dominus" app and download the instruction manual by pressing the item "Instructions and warnings". Follow its instructions to register and pair it with the installed Dominus V2 device.

The manual can be downloaded from the website www.immergas.com.

N.B.: the name of the Wi-Fi network and password to which "Dominus V2" will be connected must not contain spaces and the encryption methodology must be V2 PSK; otherwise, there may be incompatibilities.

1.6 Remote Control Application main dimensions

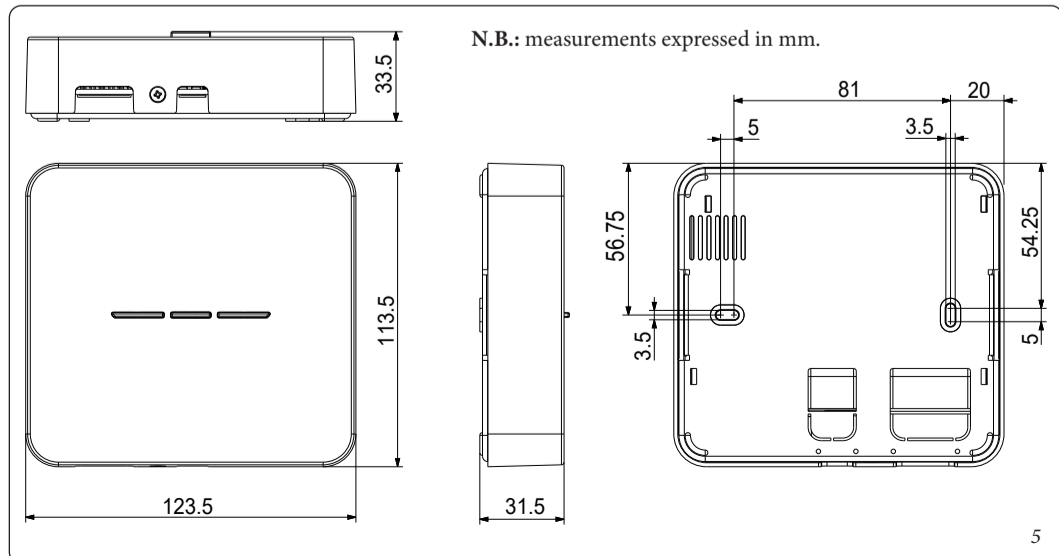

2. TECHNICAL FEATURES.

- Max absorbed power 8W
- Dominus power supply: 230 VAC 50Hz
- Functioning room temperature: 0 - +50°C
- Warehouse temperature: -10 - +60°C
- Wi-Fi protocol: Wi-Fi 802.11 b/g/n 2.4GHz
- Connection technique: 2 polarised wires
- Cable type: shielded twisted-pair where necessary
- Max. cable length of generator connection: 50 m (with 2x0.75mm² cable) (0.5 mm² min - 1.5 mm² max)
- Insulation class II
- Protection class: IP00
- Pollution degree P2
- Potential-free contact relay 230Vac 0.6A cos phi 1; 230V 0.45A cos phi 0.6; minimum current 10mA

2.1 Description of the Dominus V2 LEDs.

Led / Key	Description
LH LED 1	Dominus V2 in 'Access Point' mode (factory default / not installed in local WLAN) <ul style="list-style-type: none"> • No device connected to the WI-Fi access point: green LED flashing slowly (Frequency ~0.5Hz). • A device connected to the WI-Fi access point: green LED flashing quickly (Frequency ~4Hz). • Open connection between Dominus V2 and local WLAN: LED steady green; brief flashes during data exchange.
	Dominus V2 in STATION mode (installed in local WLAN) <ul style="list-style-type: none"> • Connected to local Wi-Fi network: Blue LED flashing slowly (Frequency ~0.5Hz) • Connected to remote server via local WLAN: blue LED steady; brief flashes during data exchange. • Not connected to local Wi-Fi network: Red LED 3 flashes repeatedly. • Connected to local Wi-Fi network, IP address not acquired: Red LED 2 flashes repeatedly. • Connected to local Wi-Fi network, IP address acquired, connection to remote server not yet executed or failed: Red LED 1 flashes repeatedly.
Central key	• This is used to issue configuration or reset commands.
RH LED 2	MOD BUS communication <ul style="list-style-type: none"> • MOD BUS Slave communication functioning: Blue LED flashing slowly (Frequency ~0.5Hz). • MOD BUS Slave communication interrupted: Red LED 2 flashes repeatedly.

2.2 Description of Dominus V2 pairings to the respective generator.

Generator	App profile name	Connection diagram	Generator configuration parameters
Fam. Trio/Trio Pack/Trio Hydro	Trio/Trio Pack/Trio Hydro	ModBus Connection diagram (Fig. 6)	On the generator control panel, select the item 'System Supervision' in the system Service/Definitions menu and set the option 'Domin'
Fam. Magis Pro/Combo V2	Magis Pro-Combo V2	ModBus Connection diagram (Fig. 6)	On the generator control panel, set parameter 'A30' to the value 'ON'.
Fam. Magis Hercules Pro	Magis Hercules Pro	ModBus Connection diagram (Fig. 6)	On the generator control panel, select the item 'System Supervision' in the system Service/Definition menu and set the option 'Domin'
	Magis Hercules Pro Mini		
	Magis Hercules Mini Hydro		
Fam. Victrix Superior Fam. Hercules	Superior	ModBus Connection diagram (Fig. 6)	On the generator control panel, select the item 'Type' in the Service/Modbus menu and set the option 'Dominus'
Fam. Victrix Extra Fam. Victrix Maior	Maior/Extra	ModBus Connection diagram (Fig. 6)	On the generator control panel, select the parameter 'P18' in the 'P' menu and set the option '1'
Fam. Victrix Tera V2	Victrix Tera	ImgBus Connection diagram (Fig. 7/8)	Generator already configured
System Manager	System manager	ModBus Connection diagram (Fig. 6)	On the generator control panel, select the item 'B04' in the Service/Supervisor menu and set the option 'Yes'
Magis Hercules-Erp	Magis Hercules	ModBus Connection diagram (Fig. 6)	Set the parameter 'BMS' in the 'ConF' menu to the value 1.

N.B.: for more details on the column 'Generator configuration parameters' refer to the generator booklet.

3. WIRING DIAGRAMS.

3.1 Practical wiring diagram of power supply and ModBus connections.

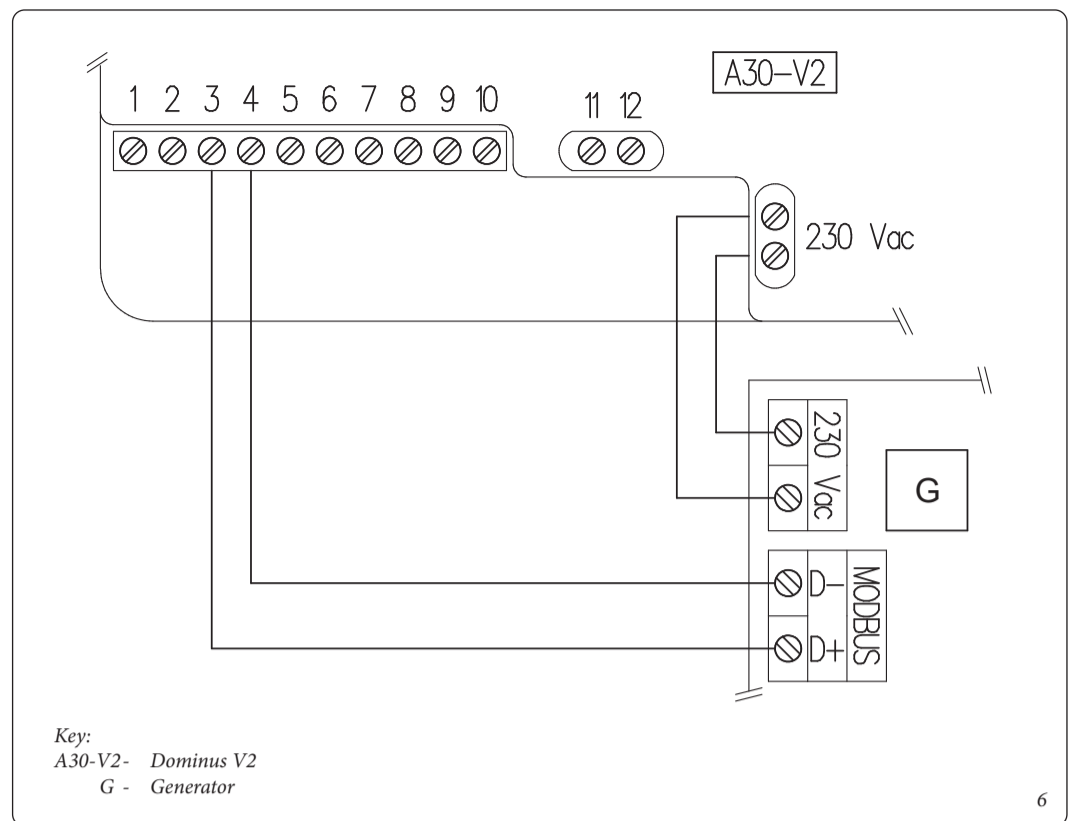

3.2 Practical wiring diagram of power supply connections and room thermostat (optional).

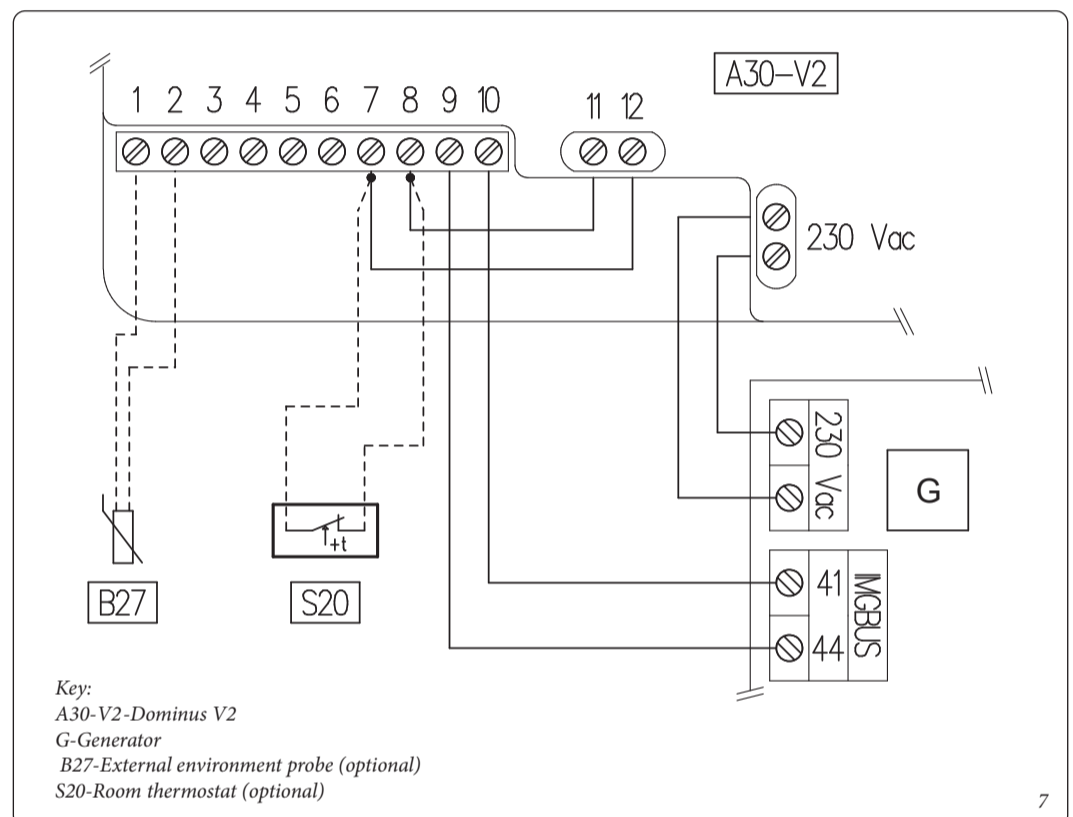

3.3 Practical wiring diagram of power supply connections and modulating thermostat CARv2 (optional).

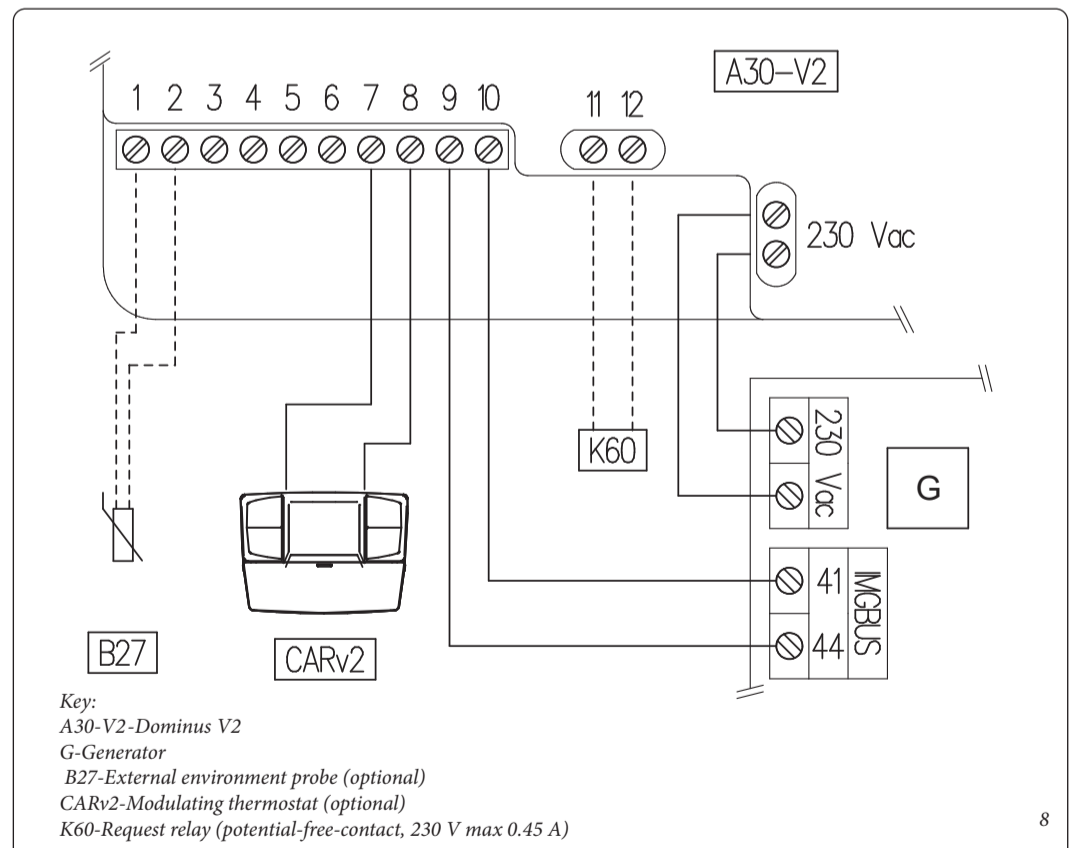

N.B.: for connection to the power supply line (230 Vac), provide a double-insulated electrical cable.

N.B.: the 230 Vac connector of the generator is identified, depending on the type of generator, as 'A B' or 'L N' auxiliary. If the latter is not available, make use of the 230Vac / 50Hz home mains supply by powering Dominus V2 in compliance with standards in force regarding electrical installation, which anyhow must include a class III overvoltage category omnipolar disconnection device.

N.B.: in configurations with room or modulating thermostat (Fig.7-8) the setting of the set flow and DHW cannot be modified from the control panel of the generator; these parameters can only be controlled by App or modulating thermostat (CARv2).

N.B.: in the configuration with modulating thermostat (Fig.8) the commands sent by App are only temporary; it is not possible to modify the calendars and modes of the CARv2 by App.



immergas.com

Immergas S.p.A.
42041 Brescello (RE) - Italy
Tel. 0522.689011
Fax 0522.680617



QR Code Android



7

QR Code iOS



8