

MAINTENANCE
INSTRUCTIONS
FOR
INSTALLERS
AND
USERS

Instructions and recommendations

IE

Installer

User

Maintenance technician

1.044623ENG



MAGIS PRO

4-6-9V2



INDEX

Dear Customer.....	4
General Recommendations.....	5
Safety symbols used.....	6
Personal protective equipment	6
1 Installing the indoor unit	7
1.1 Description of the product.....	7
1.2 Installation warnings.....	7
1.3 Indoor unit main dimensions.....	11
1.4 Minimum installation distances	12
1.5 Antifreeze protection.....	13
1.6 Indoor unit connection unit.....	14
1.7 Hydraulic connection	15
1.8 Connecting the chiller line	16
1.9 Electrical connection	16
1.10 Room chrono-thermostats (Optional).....	20
1.11 MODBUS temperature and humidity room probes (Optional)	21
1.12 Remote zone control (Optional).....	22
1.13 Dominus (Optional).....	23
1.14 Humidistat ON/OFF (Optional).....	23
1.15 External temperature probe (Optional)	24
1.16 Temperature control setting.....	25
1.17 System filling.....	26
1.18 Operating limits.....	27
1.19 Indoor unit start-up (ignition)	28
1.20 UPM3 circulation pump.....	29
1.21 UPM4 circulation pump.....	30
1.22 Kits available on request.....	31
1.23 Main components.....	32
2 Instructions for use and maintenance	33
2.1 General recommendations.....	33
2.2 Cleaning and maintenance.....	34
2.3 Control panel	35
2.4 System use.....	36
2.5 Fault and anomaly signals.....	39
2.6 Parameters and information menu.....	47
2.7 Indoor unit shutdown	51
2.8 Restore central heating system pressure.....	51
2.9 Draining the system	52
2.10 Antifreeze protection.....	52
2.11 Prolonged inactivity.....	52
2.12 Cleaning the case	52
2.13 Permanent shutdown	52
2.14 Use of the remote zone panel (Optional).....	52
3 Instructions for maintenance and initial check.....	53
3.1 General recommendations.....	53
3.2 Initial check.....	54
3.3 Yearly appliance check and maintenance.....	54
3.4 Coil maintenance	55
3.5 Hydraulic diagram	56
3.6 Wiring diagram	57
3.7 System filter	65

3.8	Troubleshooting	65
3.9	P.C.B. programming	66
3.10	First ignition parameter setting	77
3.11	Pump anti-block function	77
3.12	Three-way anti-block system	77
3.13	Radiators antifreeze function	77
3.14	Photovoltaic function	77
3.15	Outdoor unit disable function	77
3.16	Diverter valve management (summer / winter)	77
3.17	Anti-legionella function (if paired with a storage tank unit)	78
3.18	Automatic venting function	78
3.19	Preheating function	78
3.20	Screed heater function	79
3.21	Dehumidification function	80
3.22	Outdoor Unit Testmode Function	80
3.23	Outdoor Unit Pump Down Function	80
3.24	Puffer in preheating function	80
3.25	Night mode function	80
3.26	System setpoint correction function	80
3.27	Heating / cooling selector function	81
3.28	DHW recirculation function	81
3.29	Casing removal	82
4	Technical data	85
4.1	Technical data table	85
4.2	Magis PRO 4 V2 product fiche (in compliance with regulation 811/2013)	87
4.3	Magis PRO 6 V2 product fiche (in compliance with Regulation 811/2013)	89
4.4	Magis PRO 9 V2 product fiche (in compliance with Regulation 811/2013)	91
4.5	Magis PRO 4 V2 product fiche paired with Super Trio (in compliance with Regulation 811/2013)	93
4.6	Magis PRO 6 V2 product fiche paired with Super Trio (in compliance with Regulation 811/2013)	95
4.7	Magis PRO 9 V2 product fiche paired with Super Trio (in compliance with Regulation 811/2013)	97
4.8	Parameters for filling in the package fiche	99

Dear Customer

Congratulations for having chosen a top-quality Immergas product, able to assure well-being and safety for a long period of time. As an Immergas customer you can also count on a Qualified Authorised After-Sales Technical Assistance Centre, prepared and updated to guarantee constant efficiency of your appliance. Read the following pages carefully: you will be able to draw useful tips on the proper use of the device, compliance with which will confirm your satisfaction with the Immergas product.

For assistance and routine maintenance, contact Authorised Technical Service Centres: they have original spare parts and are specifically trained directly by the manufacturer.

Thermal systems must undergo periodic maintenance and scheduled checks of the energy efficiency in compliance with national, regional or local provisions in force.

The company **IMMERGAS S.p.A.**, with registered office in via Cisa Ligure 95 42041 Brescello (RE), declares that the design, manufacturing and after-sales assistance processes comply with the requirements of standard **UNI EN ISO 9001:2015**.

For further details on the product CE marking, request a copy of the Declaration of Conformity from the manufacturer, specifying the appliance model and the language of the country.

The manufacturer declines all liability due to printing or transcription errors, reserving the right to make any modifications to its technical and commercial documents without forewarning.



GENERAL RECOMMENDATIONS

This book contains important information for the:

Installer (section 1);

User (section 2);

Maintenance Technician (section 3).

For instructions on the AUDAX PRO V2 outdoor condensing unit, please refer to the relevant instruction manual;

- The user must carefully read the instructions in the specific section (section 2).
- The user must limit operations on the appliance only to those explicitly allowed in the specific section.
- **Every operation carried out on the heat pump (e.g. set up, inspection, installation and commissioning), must mandatorily be performed by authorised personnel alone and in possession of a technical engineering or professional degree qualifying them to perform these tasks. They must also have attended a refresher course acknowledged by competent authorities. This particularly applies to personal specialised in C.H. and air-conditioning systems and qualified electricians who, due to their specialised training, skills and experience are experts in the correct installation and maintenance of C.H., cooling and air-conditioning systems.**
- The appliance must be installed by qualified and professionally trained personnel.
- The instruction booklet is an integral and essential part of the product and must be given to the new user in the case of transfer or succession of ownership.
- It must be stored with care and consulted carefully, as all of the warnings provide important safety indications for installation, use and maintenance stages.
- In compliance with the legislation in force, the systems must be designed by qualified professionals, within the dimensional limits established by the Law. Installation and maintenance must be performed in compliance with the regulations in force, according to the manufacturer's instructions and by professionally qualified staff, meaning staff with specific technical skills in the plant sector, as provided for by Law.
- Improper installation or assembly of the Immergas device and/or components, accessories, kits and devices can cause unexpected problems for people, animals and objects. Read the instructions provided with the product carefully to ensure proper installation.
- This instructions manual provides technical information for installing Immergas products. As for the other issues related to the installation of products (e.g. safety at the workplace, environmental protection, accident prevention), it is necessary to comply with the provisions of the standards in force and the principles of good practice.
- All Immergas products are protected with suitable transport packaging.
- The material must be stored in a dry place protected from the weather.
- Damaged products must not be installed.
- Maintenance must be carried out by skilled technical staff. For example, the Authorised Service Centre that represents a guarantee of qualifications and professionalism.
- The appliance must only be destined for the use for which it has been expressly declared. Any other use will be considered improper and therefore potentially dangerous.
- If errors occur during installation, operation and maintenance, due to non-compliance with technical laws in force, standards or instructions contained in this booklet (or however supplied by the manufacturer), the manufacturer is excluded from any contractual and extra-contractual liability for any damages and the device warranty is invalidated.
- In the event of malfunctions, faults or incorrect operation, turn the appliance off and contact an authorised company (e.g. the Authorised Technical Assistance Centre, which has specifically trained staff and original spare parts). Do not attempt to modify or repair the appliance alone.

SAFETY SYMBOLS USED



GENERIC HAZARD

Strictly follow all of the indications next to the pictogram. Failure to follow the indications can generate hazard situations resulting in possible harm to the health of the operator and user in general, and/or property damage.



ELECTRICAL HAZARD

Strictly follow all of the indications next to the pictogram. The symbol indicates the appliance's electrical components or, in this manual, identifies actions that can cause an electrical hazard.



WARNING FOR INSTALLER

Read the instruction booklet carefully before installing the product.



LOW FLAMMABILITY MATERIAL

The symbol indicates that the appliance contains low flammability material.



WARNINGS

Strictly follow all of the indications next to the pictogram. Failure to follow the indications can generate hazard situations resulting in possible minor injuries to the health of both the operator and the user in general, and/or slight material damage.



ATTENTION

Read and understand the instructions of the appliance before carrying out any operation, carefully following the instructions given. Failure to observe the instructions may result in malfunction of the unit.



INFORMATION

Indicates useful tips or additional information.



EARTH TERMINAL CONNECTION

The symbol identifies the appliance's earth terminal connection point.



DISPOSAL WARNING

The user must not dispose of the appliance at the end of its service life as municipal waste, but send it to appropriate collection centres.

PERSONAL PROTECTIVE EQUIPMENT



SAFETY GLOVES



EYE PROTECTION



SAFETY FOOTWEAR

1 INSTALLING THE INDOOR UNIT

1.1 DESCRIPTION OF THE PRODUCT.

Magis Pro 4-6-9 V2 is a heat pump consisting of:

- Magis Pro indoor unit (hereinafter it will only be referred to as indoor unit);
- Audax Pro 4-6-9 V2 outdoor condensing unit (hereinafter it will only be referred to as outdoor unit).

Magis Pro V2 is perfectly operational only if the two units are correctly powered and interconnected.

The indoor unit was designed solely for wall mounted installations for heating and air conditioning (and to produce domestic hot water for domestic use and similar purposes only if paired with a storage tank unit).

For normal operation it must be paired with the following outdoor units:

- Audax Pro 4 V2 outdoor condensing unit;
- Audax Pro 6 V2 outdoor condensing unit;
- Audax Pro 9 V2 outdoor condensing unit.

Comply with all of the rules regarding safety and the use of both appliances.

1.2 INSTALLATION WARNINGS



Operators who install and service the appliance must wear the personal protective equipment required by applicable law.



The place of installation of the appliance and relative Immergas accessories must have suitable features (technical and structural), such as to allow for (always in safe, efficient and comfortable conditions):

- installation (according to the provisions of technical legislation and technical regulations);
- maintenance operations (including scheduled, periodic, routine and special maintenance);
- removal (to outdoors in the place for loading and transporting the appliances and components) as well as the eventual replacement of those with appliances and/or equivalent components.



The wall surface must be smooth, without any protrusions or recesses enabling access to the rear part. They are not designed to be installed on plinths or floors (Fig. 1).



Installation must be carried out according to regulation standards, current legislation and in compliance with local technical regulations and the required technical procedures.

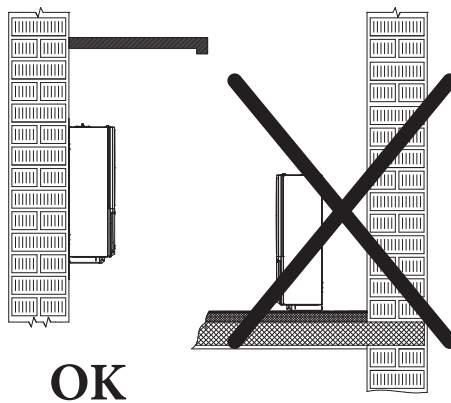

1



The appliance operates with R32 refrigerant gas.

This gas is ODOURLESS.

Pay the utmost attention

Strictly follow the instruction handbook of the Audax Pro V2 outdoor condensing unit before installation and any type of operation on the cooling line.



R32 refrigerant gas belongs to the low flammability refrigerant category: class A2L according to standard ISO 817. It guarantees high performance with low environmental impact. The new gas reduces the potential environmental impact by one third compared to R410A, having less effect on global warming (GWP 675).



The manufacturer declines all liability in the event of damage caused by appliances removed from other systems or for any non-conformities with such equipment.



Only a professionally enabled company is authorised to install Immergas appliances.



Check the environmental operating conditions of all parts relevant to installation, referring to this booklet.



If installing a kit or servicing the appliance, always empty the system's circuit first so as not to compromise the appliance's electrical safety (Parag. 2.9).

Always disconnect the appliance from voltage and, depending on the type of operation, decrease the pressure and/or bring it to zero in the system circuit.



Before installing the appliance, ensure that it is delivered in perfect condition; if in doubt, contact the supplier immediately. Packing materials (staples, nails, plastic bags, polystyrene foam, etc.) constitute a hazard and must be kept out of the reach of children.

If the appliance is installed inside or between cabinets, ensure sufficient space for routine servicing; for minimum installation distances, see Fig. 4.



Keep all flammable objects away from the appliance (paper, rags, plastic, polystyrene, etc.).



For the aforementioned reasons, we recommend not placing furnishings, furniture, etc. under the indoor unit.



Any modification to the appliance that is not explicitly indicated in this section of the booklet is forbidden.



In any configuration do not install the indoor unit and outdoor unit at altitudes above 2000 m.

Installation standards



This indoor unit can be installed outdoors in a partially protected area.

A partially protected area is one in which the indoor unit is not exposed to the direct action of the weather (rain, snow, hail, etc.).



This type of installation is possible when permitted by the laws in force in the appliance's country of destination.



Do not install on the vertical projection of hobs.



Do not install in places/rooms that constitute public areas of apartment buildings, internal stairways or other escape routes (e.g. floor landings, entrance halls, etc.).



Do not install near sources of heat.

Using specific kits, the indoor unit can be paired with other Immergas products and installed inside an outdoor wall using the specific Solar Container recessed frame or mounted on an indoor wall in the Domus Container.



Pay attention not to generate sparks as follows:

- **Do not remove the fuses while the unit is on.**
- **Do not unplug the unit while it is on.**

It is recommended to install the outlet high up. Lay the cables in such a way that they do not get tangled.



Installing the wall recessed frame kit must guarantee the indoor unit stable, efficient support.

The recessed frame kit ensures appropriate support only if installed correctly (according to the rules of good practice), following the instructions on its instructions leaflet.

The recessed frame for the indoor unit is not a supporting structure and must not replace the wall removed. It is necessary to position the boiler inside the wall.

For safety reasons against any leaks it is necessary to plaster the housing compartment of the indoor unit in the brick wall.



Wall mounting of the indoor unit must guarantee stable and efficient support for the generator.

The plugs (standard supply) are only to be used to fix the indoor unit to the wall; they only ensure adequate support if inserted correctly (according to technical standards) in walls made of solid or semi-hollow brick or block. In the case of walls made from hollow brick or block, partitions with limited static properties, or in any case walls other than those indicated, a static test must be carried out to ensure adequate mount.



These appliances are used to heat water to below boiling temperature in atmospheric pressure.



They must be attached to a heating system suitable for their capacity and voltage.



“Anti-Legionella” heat treatment of the Immergas storage tank (only if paired with a storage tank unit and function enabled when the system is provided with temperature control).



The storage tank unit must also be installed in an environment in which the temperature cannot fall below 0°C.



Anti-Legionella can only be activated if the optional DHW electrical resistance is installed;
The anti-Legionella function is programmed directly on the control panel.

During this phase, the temperature of the water inside the tank exceeds 60°C with the subsequent risk of burns. Keep this domestic hot water treatment under control (and inform the users) to prevent unforeseeable damage to people, animals, things. If required install a thermostatic valve on the domestic hot water outlet to prevent scalding.



The appliance is built to also operate in cooling mode. If cold water production, during summer, could interfere and damage the central heating only systems, necessary precautions must be taken to prevent that an unintentional production of cold water enters the heating only system.



The minimum water content required within the system is 30 litres; otherwise, it will be necessary to install an inertial storage tank (optional). For proper system operation, make sure that the minimum flow rate in operating conditions never drops below 500l/h.



When the circulation within each room central heating loop is controlled by remotely operated valves, it is important to guarantee the minimum water content (30 litres), even if all the valves are closed.

When the circulation within each or certain room central heating loops is controlled by remotely operated valves, it is important to guarantee the minimum flow rate, even if all the valves are closed. It is necessary to have a loop that is always open on the system (by-pass or non-intercepted zone), to allow some functions such as, for example, the antifreeze function.



Failure to comply with the above implies personal responsibility and invalidates the warranty.

Data nameplate positioning

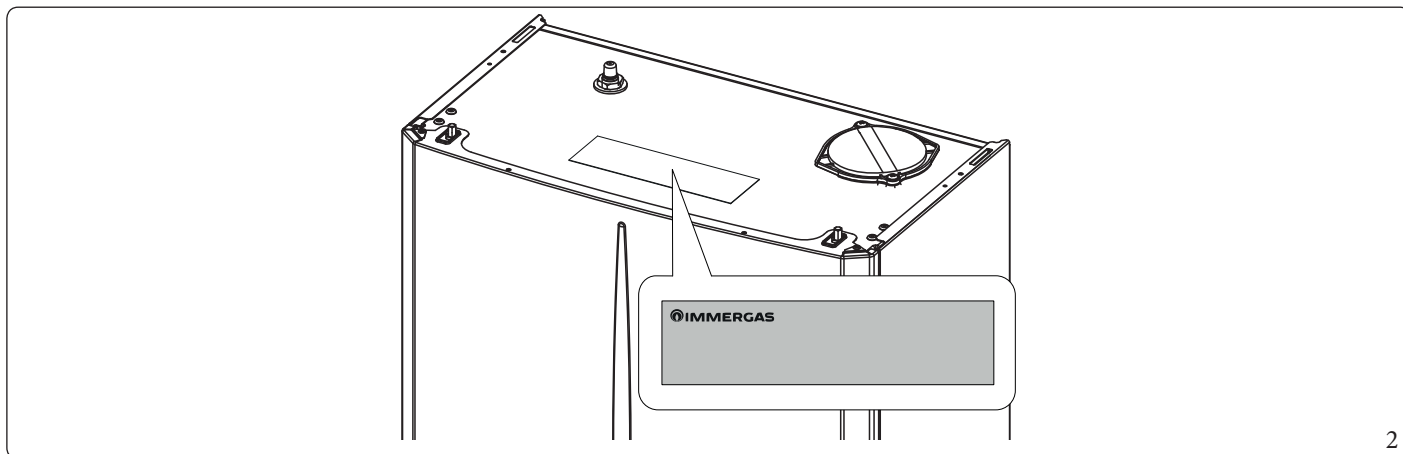

2

1.3 INDOOR UNIT MAIN DIMENSIONS

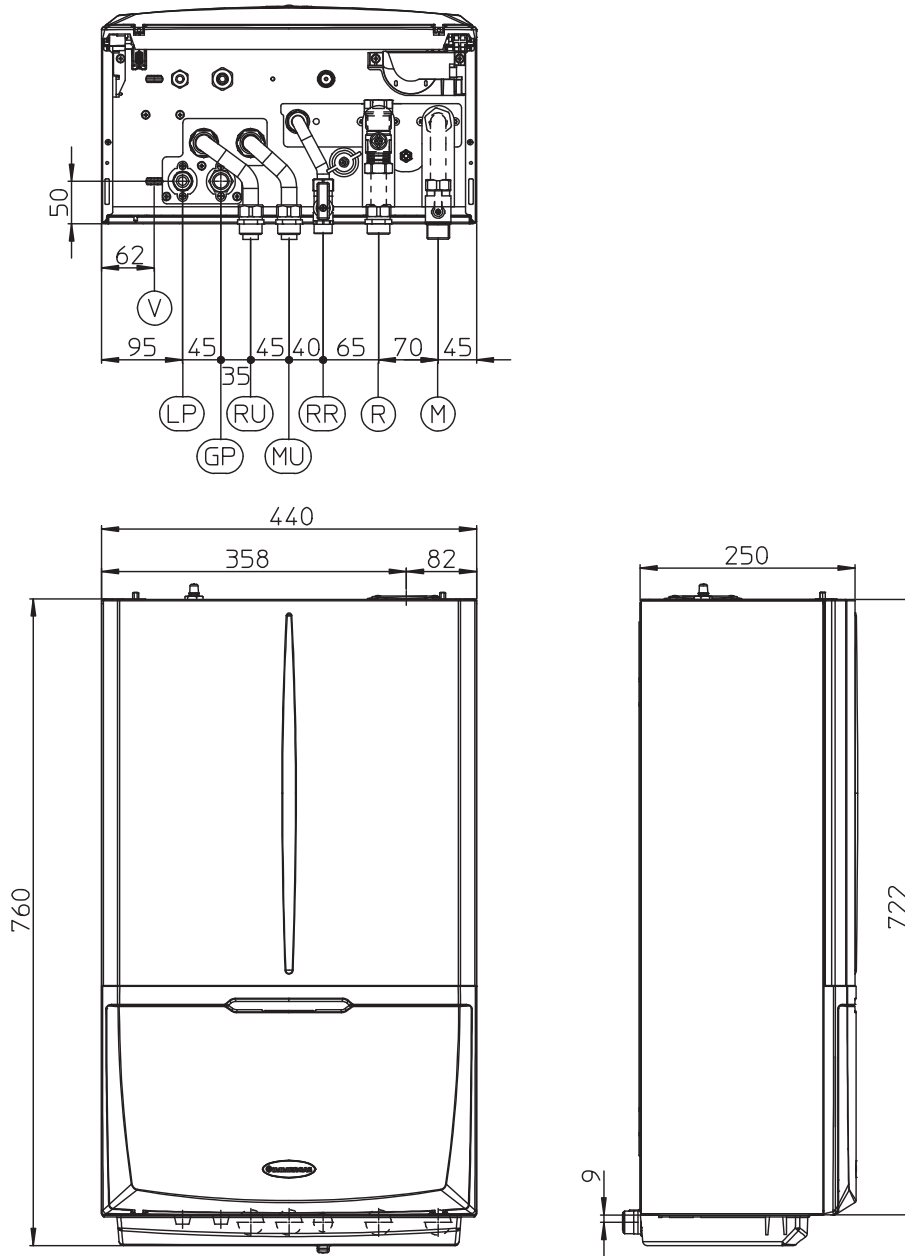

3

Height (mm)		Width (mm)		Depth (mm)	
760		440		250	
CONNECTIONS					
LINE CHILLERLINE		D.H.W.		SYSTEM	
LP	GP	RR	R - M	RU - MU	
SAE 1/4"	SAE 5/8"	G 1/2"	G 3/4"	G 3/4"	

Key (Fig. 3):

- V - Electrical connection
- RR - System filling
- RU - Storage tank unit return
- MU - Storage tank unit flow
- R - System return
- M - System flow
- LP - Chiller line - liquid phase
- GP - Chiller line - gaseous phase

INSTALLER

USER

MAINTENANCE TECHNICIAN

TECHNICAL DATA

1.4 MINIMUM INSTALLATION DISTANCES

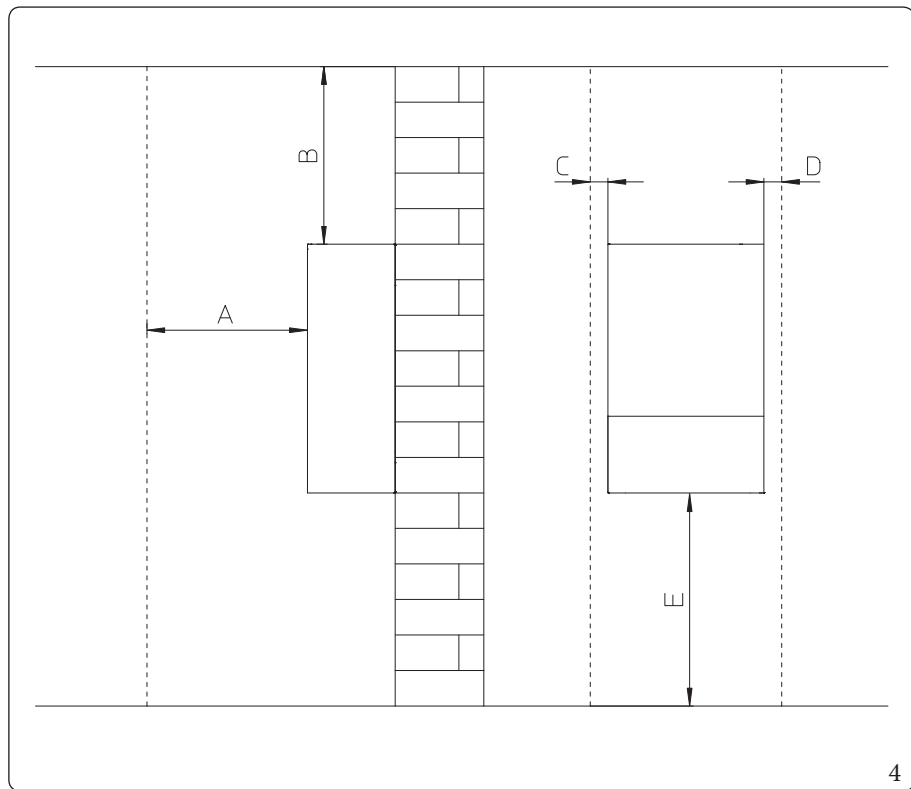

- Key (Fig. 4):
- A - 450 mm
 - B - 350 mm
 - C - 30 mm
 - D - 30 mm
 - E - 350 mm

4

1.5 ANTIFREEZE PROTECTION

Minimum temperature -5°C

The indoor unit comes standard with an anti-freeze function that activates the outdoor unit when the temperature of the water inside of it falls below 4°C.

 In these conditions, the indoor unit is protected against freezing up to an ambient temperature of -5°C.

 If the indoor unit is installed in a place where the temperature drops below -5°C, the appliance can freeze.

To prevent the risk of freezing follow the instructions below:

 The excessive use of glycol could jeopardise the proper functioning of the appliance.

 **Follow the supplier's instructions for the life cycle duration and possible disposal of the anti-freeze liquid.**

- protect the central heating circuit from freezing by inserting a good-quality antifreeze liquid into this circuit, which is specially suited for central heating systems and which is manufacturer guaranteed not to cause damage to the heat exchanger or other components of the indoor unit. The antifreeze liquid must not be harmful to one's health. The instructions of the manufacturer of this liquid must be strictly followed regarding the necessary percentage with respect to the minimum temperature at which the system must be kept.
- the materials used for the central heating circuit of Immergas indoor unit resist ethylene and propylene glycol based antifreeze liquids (if the mixtures are prepared perfectly).
- An aqueous solution must be made with potential pollution class of water 2 (EN 1717:2002 or local standards in force).

Minimum temperature -15°C

Protect the condensate drain siphon and the system fill-up pipe from freezing by using an accessory that is supplied on request (antifreeze kit), including an electric resistance, the relevant wiring and a control thermostat (carefully read the installation instructions in the accessory kit pack).

 In the previously mentioned conditions and with the addition of the antifreeze kit, the indoor unit is protected against freezing up to a temperature of -15°C.

Indoor unit anti-freeze protection (both -5°C and -15°C) is only ensured if:

- indoor unit and outdoor unit are properly connected to each other and to the electrical power supply circuits;
- the units are continuously powered;
- the indoor unit is not in "off" mode;
- the units are not in anomaly (Parag. 2.5);
- the antifreeze unit and/or kit essential components are not faulty.

The warranty does not cover damage due to interruption of the electrical power supply and failure to comply with that stated on the previous pages.

 If the indoor unit is installed in places where the temperature drops below 0°C, the domestic hot water connection pipes must be insulated (if paired with storage tank unit).

 The antifreeze systems described in this chapter are only to protect the indoor unit. The presence of these functions and devices does not exclude the possibility of parts of the circuits outside the indoor unit from freezing.

1.6 INDOOR UNIT CONNECTION UNIT

- The hydraulic connection unit is supplied as per standard with Magis Pro V2. Make the hydraulic connection as shown below, making sure to protect the system flow and return pipes with their supplied insulating sheaths.
- The R32 circuit wall connection unit is supplied as an extra kit. Connect the circuit, following the instructions provided in the outdoor unit instructions booklet.

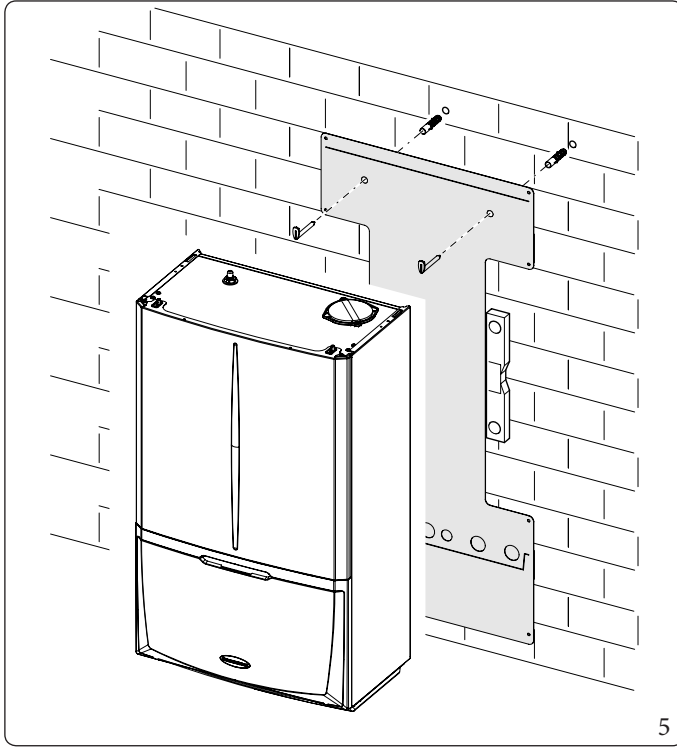

The hydraulic connection kit includes (Fig. 5):

- N°1 - Adjustable expansion bolts
- N°2 - Indoor unit support hooks
- N°1 - G 3/4" storage tank unit return pipe (RU)
- N°1 - G 3/4" storage tank unit flow pipe (MU)
- N°1 - G 1/2" system filling pipe (RR)
- N°1 - G 1/2" ball valve (RR)
- N°1 - G 3/4" system return pipe (R)
- N°1 - 3/4" system flow pipe G (M)
- N°1 - G 3/4" ball valve (M)
- N°2 - Insulating sheath for system pipes (R - M)
- N°4 - G 3/4" telescopic fittings (RU - MU - R)

Gaskets, screws and seal O-Ring

The R32 circuit wall connection kit (optional) includes:

- N°1 - SAE 1/4" liquid phase chiller line pipe (LP)
- N°1 - SAE 5/8" gaseous phase chiller line pipe (GP)

Already installed on the module:

- N°1 - System shut-off cock with G 3/4" filter (R)

1.7 HYDRAULIC CONNECTION



In order not to void the warranty, before making indoor unit connections, carefully clean the heating system (pipes, radiators, etc.) with special pickling or de-scaling products to remove any deposits that could jeopardise proper hydronic module operation.

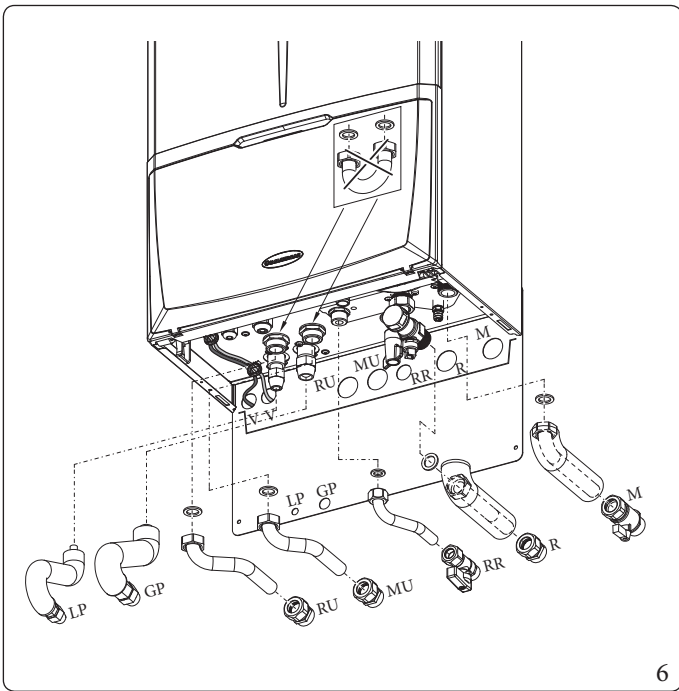

Key (Fig. 6):

- V - Electrical connection
- RR - System filling
- RU - Storage tank unit return
- MU - Storage tank unit flow
- R - System return
- M - System flow
- LP - Chiller line - liquid phase
- GP - Chiller line - gaseous phase

A treatment of the heating and water system water is required, in compliance with the technical standards in force, in order to protect the system and the appliance from deposits (e.g. scale), slurry or other hazardous deposits.

Water connections must be made in a rational way using the couplings on the indoor unit template.



The manufacturer declines all liability in the event of damage caused by the installation of an automatic filling system.

In order to meet the system requirements established by EN 1717 in terms of pollution of drinking water, we recommend installing the IMMERGAS anti-backflow kit to be used upstream of the cold water inlet connection of the indoor unit. We also recommend using category 2 heat transfer fluid (ex: water + glycol) in the internal unit primary circuit (heating and/or cooling circuit), as defined in standard EN 1717.



To preserve the duration of appliance efficiency features, in the presence of water whose features can lead to the deposit of lime scale, installation of the “polyphosphate dispenser” kit is recommended.

1.8 CONNECTING THE CHILLER LINE

As far as connecting the cooling line is concerned, all the instructions contained in the outdoor unit instructions booklet must be followed.

Make the connections directly on the indoor unit couplings, or use the rear outlet kit (optional).

1.9 ELECTRICAL CONNECTION

The internal unit has an IPX4D degree of protection; electrical safety of the appliance is achieved only when it is properly connected to an efficient earthing system, as specified by current safety standards.



The manufacturer declines any responsibility for damage or physical injury caused by failure to connect the indoor unit to an efficient earthing system or failure to comply with the IEC reference standards.

Connection cables must respect the prearranged routes.

Use 3 clips (c) (not supplied) to group the individual cables (max. 1.5 mm² into the lower terminal board.

Use the specific fairleads (d) on the left side, making sure to put at most 2 multi-polar cables (max 3 x 1 mm²) in each fairlead.

The figure 7 shows cables in a hypothetical connection. To make the connections based on your own requirements, see the instructions below.

Open the control panel connections compartment

Fig. 7.

To carry out electrical connections, all you have to do is open the connections compartment as follows.

1. Remove the front panel.
2. Disassemble the cover.
3. Loosen the screws (a).
4. Remove the cover (b) from the control panel (c).

At this point, you can access the terminal board.

Also ensure that the electrical installation corresponds to maximum absorbed power specifications as shown on the indoor unit data-plate.

Indoor units are supplied complete with an “X” type power cable without plug.



The power supply cable must be connected to a 230V ±10% / 50Hz mains supply respecting L-N polarity and earth connection; this network must also have a multi-pole circuit breaker with class III overvoltage category in compliance with installation regulations.



To protect from possible dispersions of DC voltage, it is necessary to provide a type A differential safety device.



**If the power cable is damaged, contact a qualified company (e.g. the Authorised Technical Assistance Centre) for its replacement to avoid a hazard.
It is recommended to contact a qualified company (e.g. the Authorised After-Sales Technical Assistance Centre) for replacement to avoid a hazard.**

The power cable must be laid as shown (Fig. 7).

If the fuses on the circuit boards need to be replaced, this must also be done by qualified personnel: use a F3.15A H250V fuse on the P.C.B.

For the main power supply to the appliance, never use adapters, multiple sockets or extension leads.

Make the various electrical connections according to your needs (Fig. 8, 9).

Outdoor unit electrical connection

The indoor unit must be coupled to an outdoor unit by connecting terminals F1 and F2 as shown in the wiring diagram (Fig. 9). The indoor unit is powered at 230 V, regardless of the outdoor unit.

Configure the indoor unit parameters as indicated in paragraph (Parag. 3.9).

Photovoltaic system installation

Connecting the product to a photovoltaic system enhances use of the outdoor unit when the photovoltaic panels are operating. Carry out the connection as indicated (Fig. 8).

Dehumidifiers

Carry out the connection as indicated (Fig. 9). To complete the connection operations, insert the 2-relay Board optional kit.

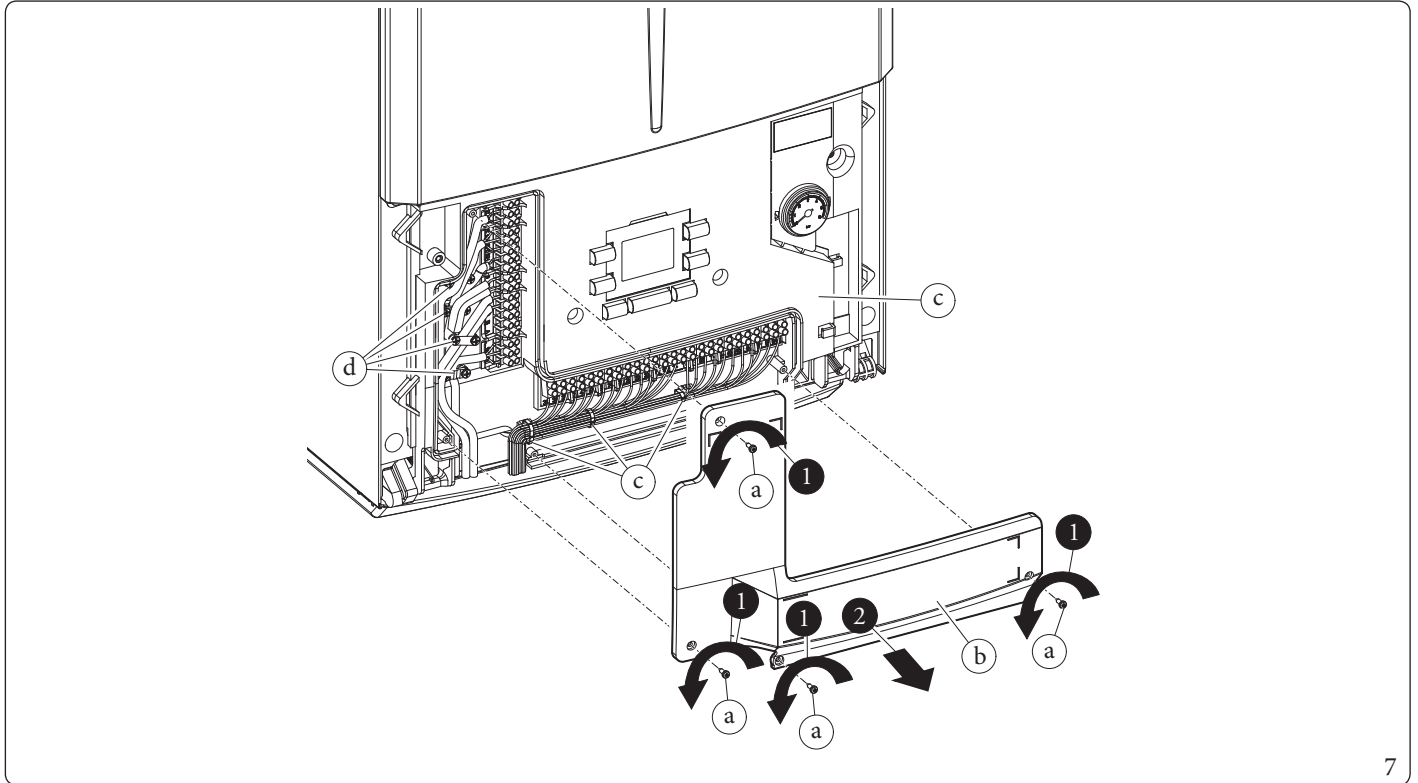

Vertical terminal block electrical connection diagram.

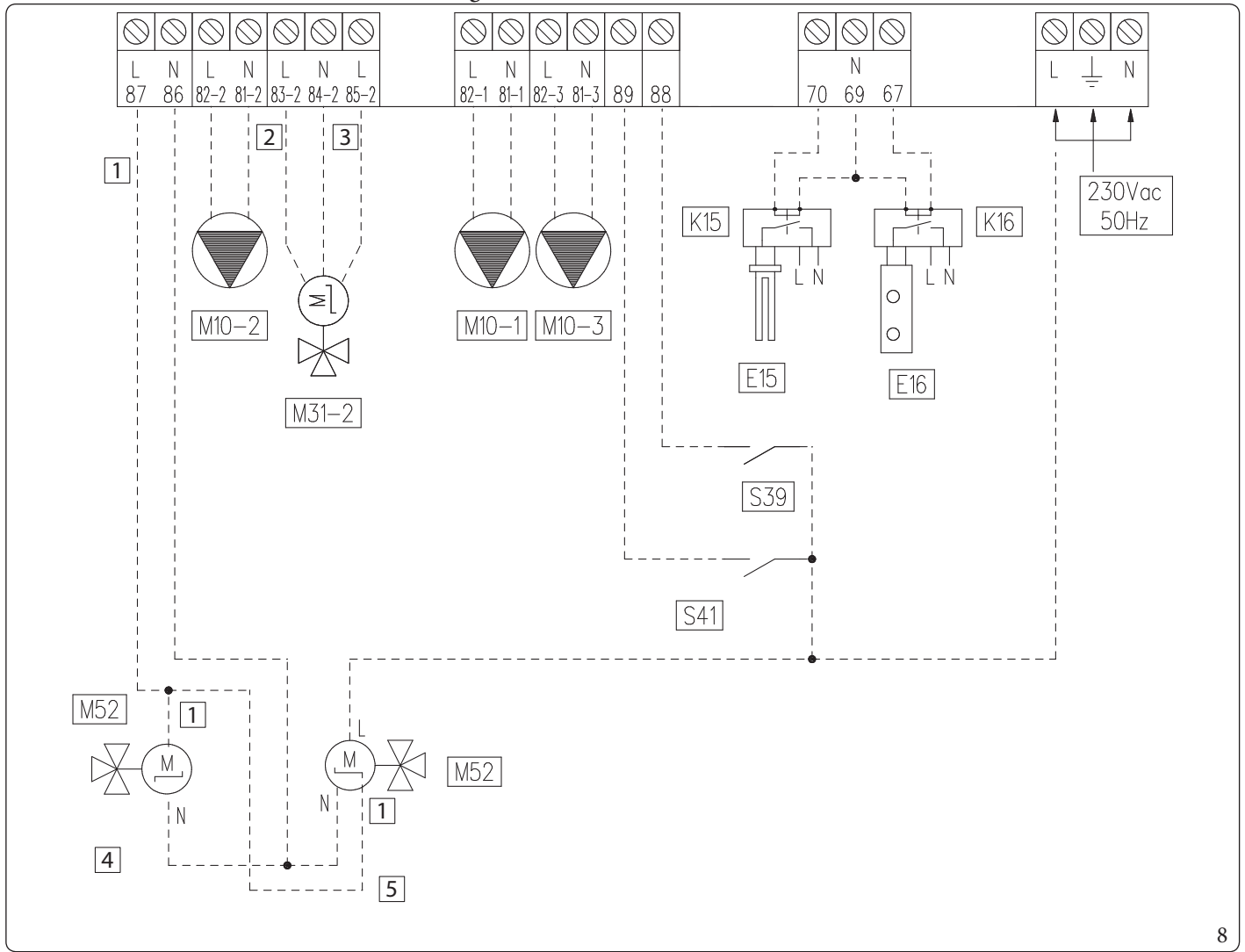

8

A 3rd zone (mixed) can also be managed on the system by means of the configurable relay interface kit (optional). In this case, the zone 3 pump must be connected according to diagram (M10-3).

The zone 3 dehumidifier, if any, will be managed by means of the configurable relay interface kit, which the zone 3 mixer will also be connected to.

Terminal 87		
0V	Close	Winter
230V	Open	Summer with cooling

Key (Fig. 8):

- 1 - Open/Close
- 2 - Close
- 3 - Open
- 4 - 2-point valve
- 5 - 3-point valve

- E15 - Domestic hot water integration resistance
- E16 - System integration resistance
- K15 - DHW integrative resistance relay

- K16 - System integrative resistance relay
- M10-1 - Zone 1 pump (optional)
- M10-2 - Zone 2 circulator pump (optional)
- M10-3 - Zone 3 circulator pump (optional)
- M31-2 - Zone 2 mixing valve (optional)
- M52 - Hot cold three-way (optional)
- S39 - Solar inlet
- S41 - Outdoor unit disable function

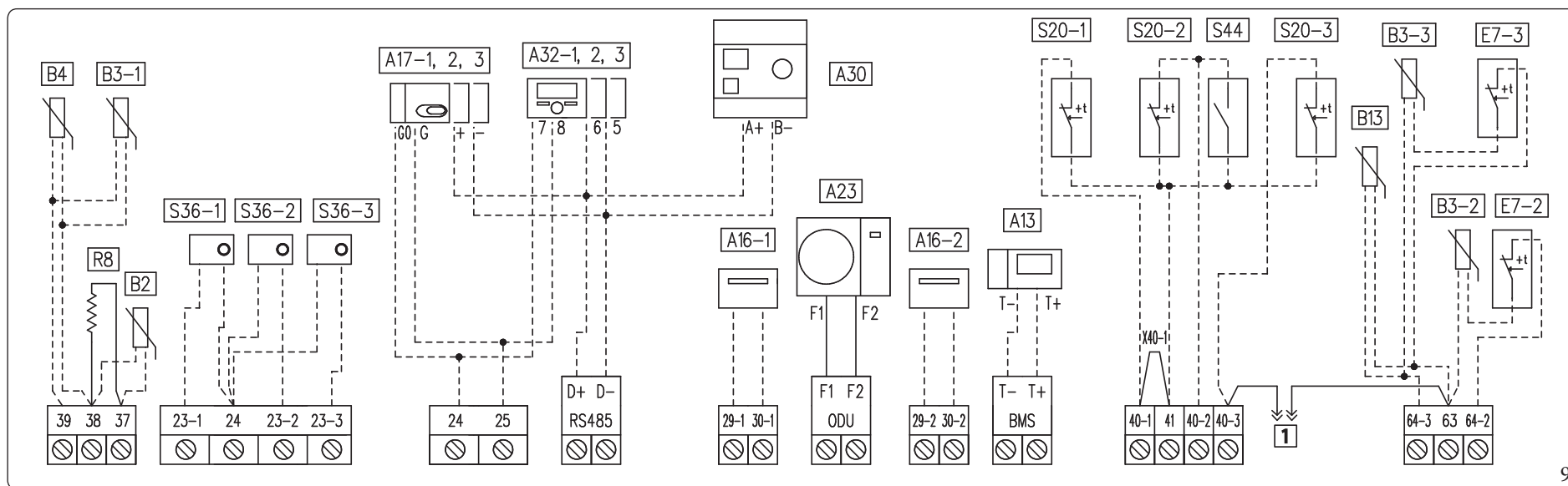

9

Key (Fig. 9):

- | | |
|---|---|
| <ul style="list-style-type: none"> A13 - System manager (optional) A16-1 - Zone 1 dehumidifier (optional with dehum. management board) A16-2 - Zone 2 dehumidifier (optional with dehum. management board) A17-1 - Zone 1 humidity sensor (optional) A17-2 - Zone 2 humidity sensor (optional) A17-3 - Zone 3 humidity sensor (optional) A23 - Outdoor unit A32-1 - Zone 1 remote panel (optional) A32-2 - Zone 2 remote panel (optional) A32-3 - Zone 3 remote panel (optional) B2 - Storage tank probe (optional) B3-1 - Zone 1 flow probe (optional) B3-2 - Zone 2 flow probe (optional) B3-3 - Zone 3 flow probe (optional) | <ul style="list-style-type: none"> B4 - External probe (optional) B13 - Central heating probe (optional) E7-2 - Zone 2 safety thermostat (low temperature) (optional) E7-3 - Zone 3 safety thermostat (low temperature) (optional) R8 - Storage tank resistance S20-1 - Zone 1 room thermostat (optional) S20-2 - Zone 2 room thermostat (optional) S20-3 - Zone 3 room thermostat (optional) S36-1 - Zone 1 humidistat (optional) S36-2 - Zone 2 humidistat (optional) S36-3 - Zone 3 humidistat (optional) S44 - Central Heating/Cooling Selector X40-1 - Zone 1 room thermostat jumper 1 - Service connector |
|---|---|

A16-1 and A16-2 dehumidifiers can be connected only after installing 2-relay board (optional).

Remove jumper X40-1 before the electrical connection of the room thermostat zone 1.

The TA inputs, 40-1 etc..., must be electrically decoupled; e.g. a single command cannot pilot multiple inputs.

With A13 available, the zone devices must not be connected.

The room thermostats of zone 2, zone 3 and contact S44 cannot be installed simultaneously.

It is not possible to install the following probes at the same time:

- Central heating probe;
- Zone 3 probe.

1.10 ROOM CHRONO-THERMOSTATS (OPTIONAL)

The indoor unit is prepared for the application of room chrono-thermostats, which are available as optional kits. All Immergas chrono-thermostats are connected with 2 wires only. A maximum of 3 temperature controllers can be applied directly to the appliance. Carefully read the user and assembly instructions contained in the accessory kit.



Disconnect power to the unit before making any electrical connections.

On/Off Immergas digital chrono-thermostat.

The chrono-thermostat allows:

- set two room temperature value: one for day (comfort temperature) and one for night (reduced temperature);
- set a weekly programme with four daily switch on and switch off times;
- selecting the required function mode from the various possible alternatives:
 - manual mode (with adjustable temperature);
 - automatic mode (with set programme);
 - forced automatic operation (momentarily changing the temperature of the automatic program).

The chrono-thermostat is powered by two 1.5V LR6 type alkaline batteries.

On/Off chrono-thermostat electrical connection (Optional).



The operations described below must be performed after having removed the voltage from the appliance.

On/Off ambient thermostat or chrono-thermostat: must be connected to the 40-1 / 41 terminals, eliminating the X40-1 jumper for zone 1 and 40-2 / 41 for zone 2 and 40-3 / 42 for zone 3.

Make sure that the On/Off thermostat contact is of the “clean” type, i.e. independent of the mains voltage, otherwise the P.C.B. would be damaged.

The connections must be made on the terminal board inside the appliance’s control panel (Fig. 9).



If the area remote panel or any other On/Off chrono-thermostat is used, arrange two separate lines in compliance with current regulations regarding electrical systems.

No indoor unit pipes must ever be used to earth the electric system or telephone lines.

Ensure elimination of this risk before making the indoor unit electrical connections.

1.11 MODBUS TEMPERATURE AND HUMIDITY ROOM PROBES (OPTIONAL)

The temperature and humidity probe is used to detect room humidity and to calculate the relative dew point by regulating the flow temperature during the cooling phase.

Connect the appliance as shown (Fig. 9);

DIP-Switch configuration table

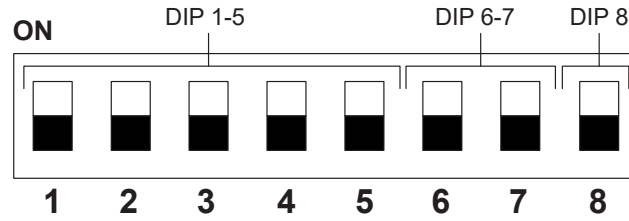

DIP 1-5 (Address)	<p>ON</p> <p>1 2 3 4 5</p>	Zone 1 (Address 131)
	<p>ON</p> <p>1 2 3 4 5</p>	Zone 2 (Address 132)
	<p>ON</p> <p>1 2 3 4 5</p>	Zone 3 (Address 133)
DIP 6-7 (Type)	<p>ON</p> <p>6 7</p>	Modbus 1 - 8 - E - 1
DIP 8 (Speed)	<p>ON</p> <p>8</p>	9600 bit/s

INSTALLER

USER

MAINTENANCE TECHNICIAN

TECHNICAL DATA

1.12 REMOTE ZONE CONTROL (OPTIONAL)

This remote device is used to adjust the setpoints and to view the main information of the zone where it was configured. Connect the appliance as shown (Fig. 9);



When the connections are complete, switch off and re-power the appliance.

To correctly configure the device, set the parameters as described below:

Assistance Menu -> Device configuration	
Slave address: Address to configure according to the zone where the device is installed	Zone 1 = 41
	Zone 2 = 42
	Zone 3 = 43
Baud Rate	9600
Parity bit	Even
Stop bits	1
Heat pump control	NO

Using a Zone Remote Panel with firmware version 2.00 or higher:

- the item "Head pump control" is no longer present;
- it is possible to enable room probe modulation;
- the dew point control can be enabled.



For correct operation it is necessary to install the jumper on the thermostat of the zone associated to the panel. If necessary, this jumper can be replaced with a safety thermostat.



A restart of the machine is recommended after connecting the remote panel.

1.13 DOMINUS (OPTIONAL)

The system can be remote controlled using the optional Dominus kit.

Connect the appliance as shown (Fig. 9);

The following is necessary to enable Dominus:

- position the Dip Switches: OFF-OFF-OFF-ON;
- set the A30 parameter on the control panel = ON;
- configure the Dominus APP profile on Magis Pro-Combo V2.



The Dominus firmware must be updated to at least revision 2.02.

For further information, consult the relative instruction sheet.

1.14 HUMIDISTAT ON/OFF (OPTIONAL)

You can make a dehumidification demand by using a humidistat.

Connect the appliance as shown (Fig. 9);

1.15 EXTERNAL TEMPERATURE PROBE (OPTIONAL)

The outdoor unit has a standard external probe that can be used as an external probe of the heat pump.

If the outdoor unit is positioned in an area that is not suitable for temperature reading, it is advisable to use an additional external probe (Fig. 10) which is available as an optional kit.

Refer to the relative instruction sheet for positioning of the external probe.

For the proper operation of the optional probe it must be connected where envisaged (Fig. 9) and then it must be enabled (Parag. 3.9).



Once the probe is enabled, switch the appliance off and back on.

The presence of the external probe allows the system flow temperature to be set automatically based on the outdoor temperature in order to adapt the heating or cooling provided to the system.

The system flow temperature is determined by the setting on the “Heat regulation” menu and by the “User” menu for the offset values based on the curves shown in the diagram (Parag. 1.16).



If the system is divided into two or three zones, the flow temperature is calculated based on the zone with the higher temperature in central heating mode and with the lower temperature in cooling mode.

The electric connection of the external probe must be made on terminals 38 and 39 on the terminal board on the indoor unit control panel (Fig. 9).

In case of failure, after having powered off and back on, the outdoor temperature is automatically detected by the external probe on the outdoor unit.

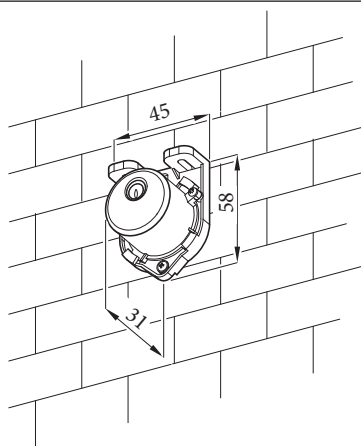

1.16 TEMPERATURE CONTROL SETTING

By setting the parameters in the “Heat regulation” menu, you can adjust how the system operates.

The curves (Fig. 11, 12, 13, 14, 15, 16) show the default settings in the various operating modes available both with external probe and without.

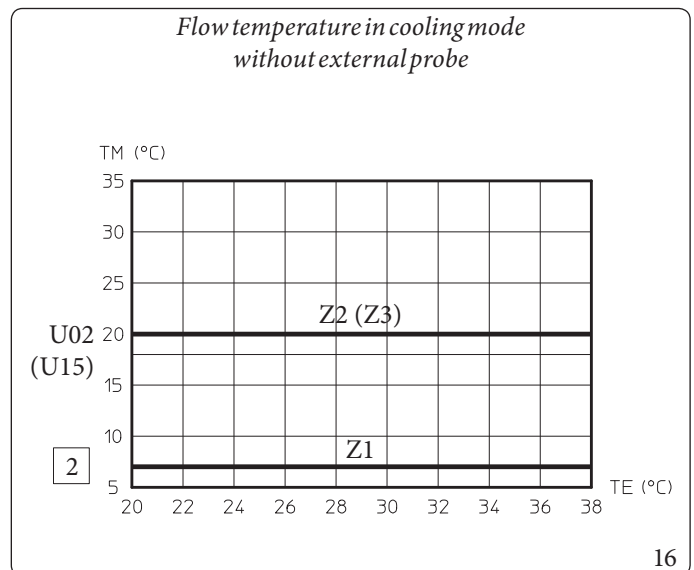
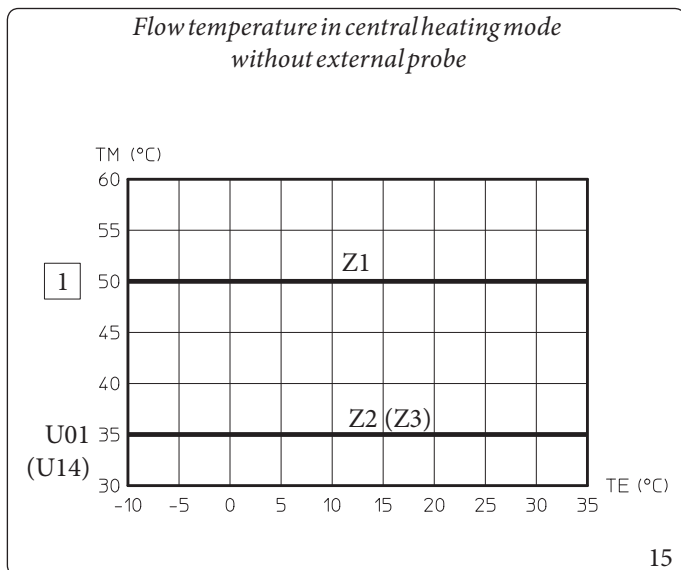
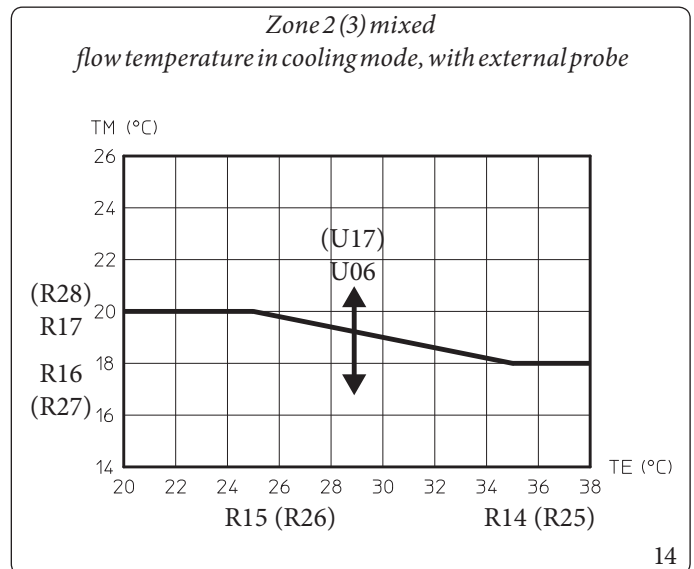
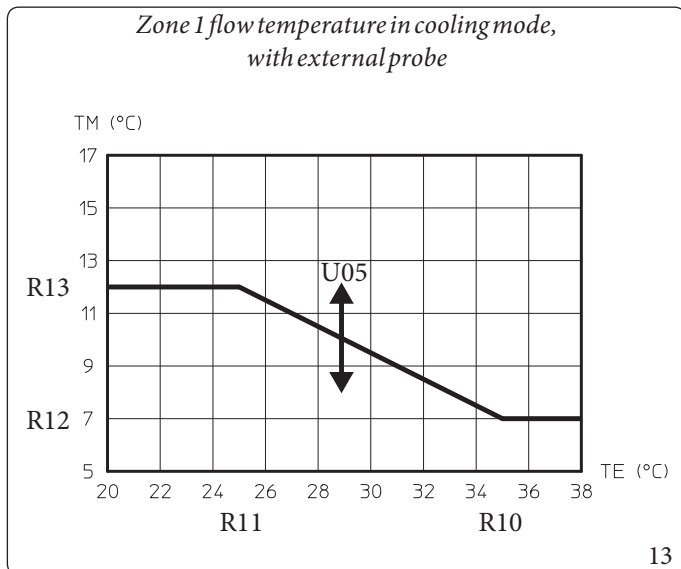
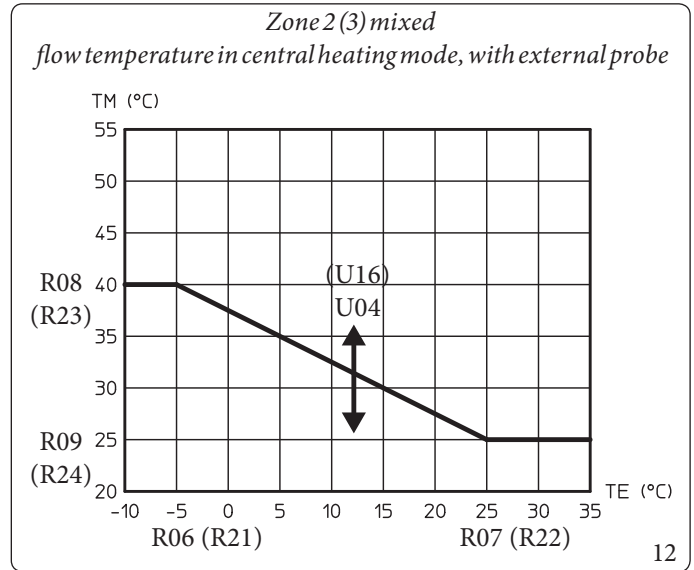
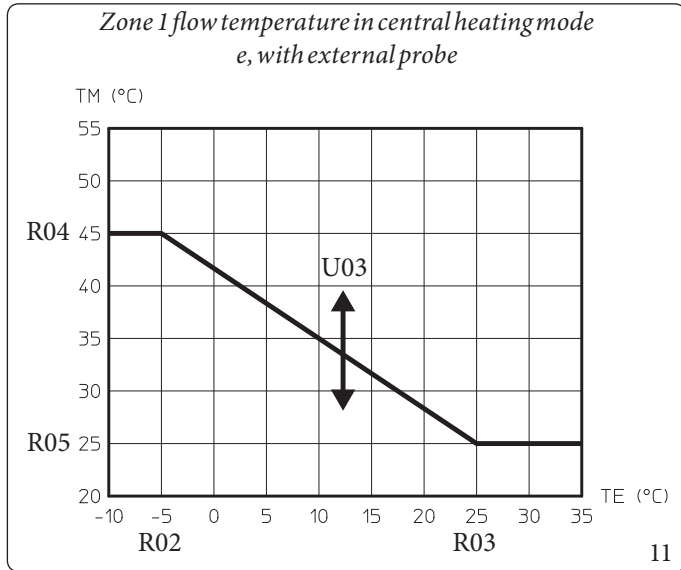

INSTALLER

USER

MAINTENANCE TECHNICIAN

TECHNICAL DATA

Key (Fig. 11,12,13,14,15,16)

1 - Central heating set

2 - Cooling set

Rxx - Temperature control menu parameter

TE - Outside temperature

TM - Flow temperature

U01 - Zone 2 flow temperature in "User" menu central heating mode

U02 - Zone 2 flow temperature in "User" menu cooling mode

U03 - Offset value compared to the curve set by the external probe on central heating zone 1

U04 - Offset value compared to the curve set by the external probe on central heating zone 2

U05 - Offset value compared to the curve set by the external probe on cooling zone 1

U06 - Offset value compared to the curve set by the external probe on cooling zone 2

U14 - Zone 3 flow temperature in "User" menu central heating mode

U15 - Zone 3 flow temperature in "User" menu cooling mode

U16 - Offset value compared to the curve set by the external probe on central heating zone 3

U17 - Offset value compared to the curve set by the external probe on cooling zone 3

Zx - Heating system zone

1.17 SYSTEM FILLING

Once the indoor unit is connected, fill the system using the filling cock (Fig. 22).

The indoor unit has one incorporated automatic vent valve located on the circulator and another on the central heating manifold.



Make sure that the hoods are loosened.

The filling cock must be closed when the indoor unit pressure gauge indicates approximately 1.2 bar.



During these operations, enable the "Venting" functions by setting the "U 50" parameter to ON, which lasts about 18 hours (Parag. 3.9).

System minimum water content.

Minimum water content favours the **proper execution of defrosting cycles** and operation in cooling mode.

To this end, the minimum amount of water to guarantee is **30 litres** for any type of system and in any operating mode.

1.18 OPERATING LIMITS

The system was designed to work in a specific range of temperatures and at a specific maximum flow temperature. The chart (Fig. 17, 18, 19) shows these limits.

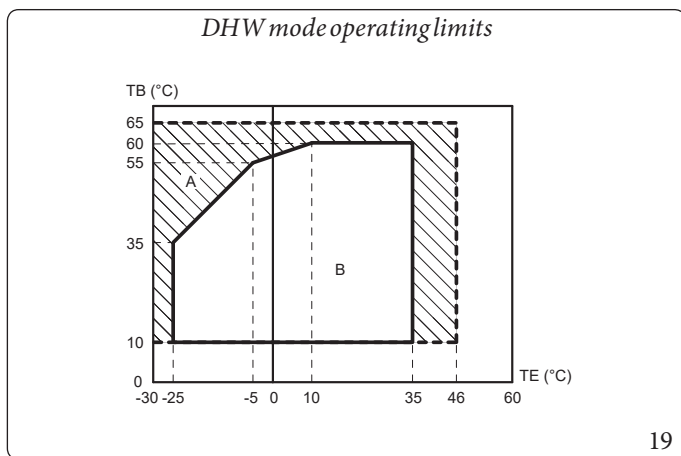
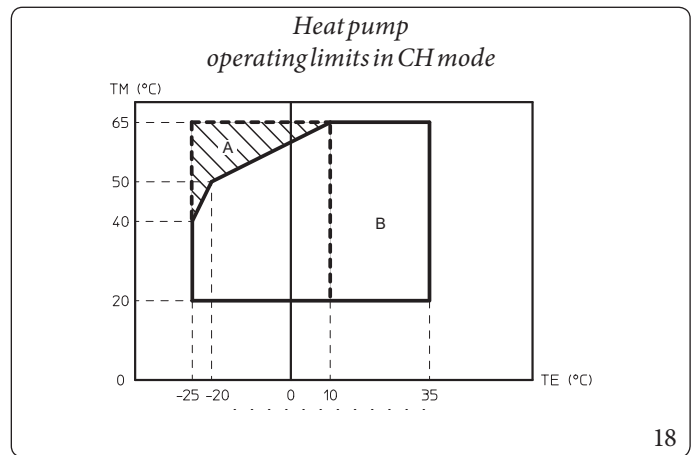
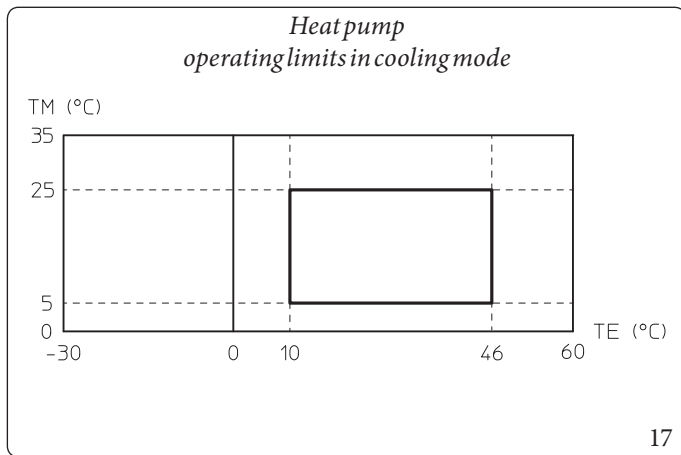

Key (Fig. 17,18,19):

TE = External temperature

TM = Flow temperature

TB = Storage tank temperature

A = With integration electrical resistance (optional)

B = DHW

INSTALLER

USER

MAINTENANCE TECHNICIAN

TECHNICAL DATA

1.19 INDOOR UNIT START-UP (IGNITION)

After having installed the chiller lines on the outdoor unit, to commission the heat pump (the operations listed below must only be performed by qualified personnel and in the presence of staff only):

1. Check connection to a 230V~50Hz power mains, correct L-N polarity and the earthing connection;
2. Switch the indoor unit on and check correct ignition;
3. Check the intervention of the main switch located upstream from the indoor unit and in the indoor unit.



The system must not be started up if even only one of the checks should be negative.



After installation, check for leaks. Toxic gas could be generated if the unit comes into contact with a source of ignition, such as thermal fan, stove and cylinders. Make sure that only refrigerant recovery cylinders are used.

1.20 UPM3 CIRCULATION PUMP

The appliance is supplied with a variable speed pump which operates as follows:

- **Fixed ("A 05" = 0):** The pump speed is fixed and corresponds to parameter "A 04".
- **ΔT constant ("A 05" = 5 K):** the pump speed varies to maintain the $\Delta T = 5K$ constant between the system flow and return. Also, you can adjust the pump operating range, by setting the maximum speed "A 04" and the minimum speed "A 03".



For proper system operation, make sure that the minimum flow rate in operating conditions never drops below 500l/h.

Pump LED.

The LED flashes green when the pump is powered and the pwm control signal is connected.



The LED lights up steady green when the pump is powered and the signal cable disconnected. In these conditions the pump works at maximum and without control.

If the pump detects an alarm, the LED switches from green to red; this can mean one of the following failures:

- low supply voltage;
- rotor seized;
- electrical error.

For a detailed description of the meaning of the red LED, refer to Paragraph 3.8.



The LED, in addition to being green or red, can also remain off.

It is normal for the LED to be off when the pump is not powered, whereas with the pump powered, the LED must be lit: if switched off, it means there is a fault.

Pump release.

If after a long period of inactivity, the circulator is blocked, adjust the screw in the centre of the head in order to manually release the motor shaft.

Take great care during this operation to avoid damage to the motor.

1.21 UPM4 CIRCULATION PUMP

The appliance is supplied with a variable speed pump which operates as follows:

- **Fixed ("A 05" = 0):** The pump speed is fixed and corresponds to parameter "A 04".
- **ΔT constant ("A 05" = 5 K):** the pump speed varies to maintain the $\Delta T = 5K$ constant between the system flow and return. Also, you can adjust the pump operating range, by setting the maximum speed "A 04" and the minimum speed "A 03".



For proper system operation, make sure that the minimum flow rate in operating conditions never drops below 500l/h.

Pump symbols (Fig. 20):

The symbol 2 flashes green (⚡) when the pump is powered and the pwm control signal is on (pump ON).

The symbol 2 stays on steady green (■) when the pump is powered and the pwm control signal is off (pump in Stand-by). In this condition it is necessary to distinguish between two cases:

- the boiler electronics are not requesting pump ignition => condition OK;
- the boiler electronics are requesting the pump ignition => faulty condition (probable disconnection of the pwm signal).

If the pump detects an alarm, symbol 1 lights up red (⚠). This can mean that there is one of the following faults:

- Low power supply voltage.
- Rotor seized (Cautiously turn the screw in the centre of the head to manually release the motor shaft).
- Electrical error.

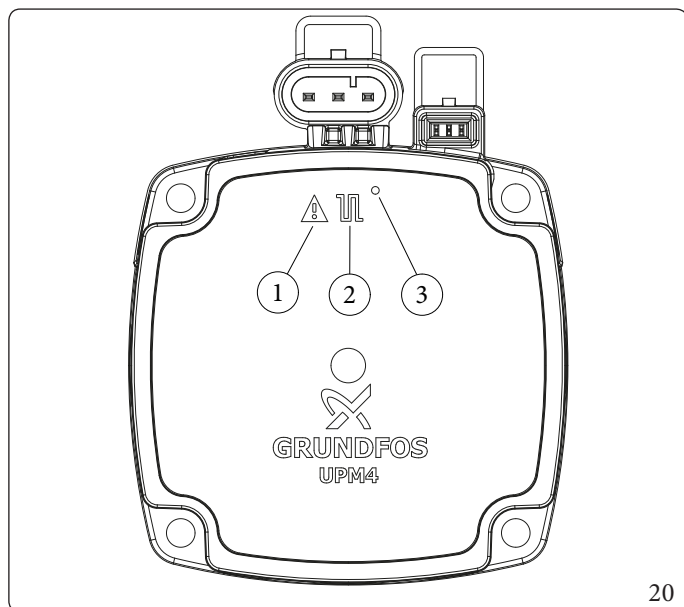

Key (Fig. 20):

- 1 - Alarm signal (Red)
- 2 - Functioning status signal (Steady green/Flashing green)
- 3 - Led (Not used on this model)

Pump release.

If after a long period of inactivity, the circulator is blocked, adjust the screw in the centre of the head in order to manually release the motor shaft.

Take great care during this operation to avoid damage to the motor.

Total head available to the system.

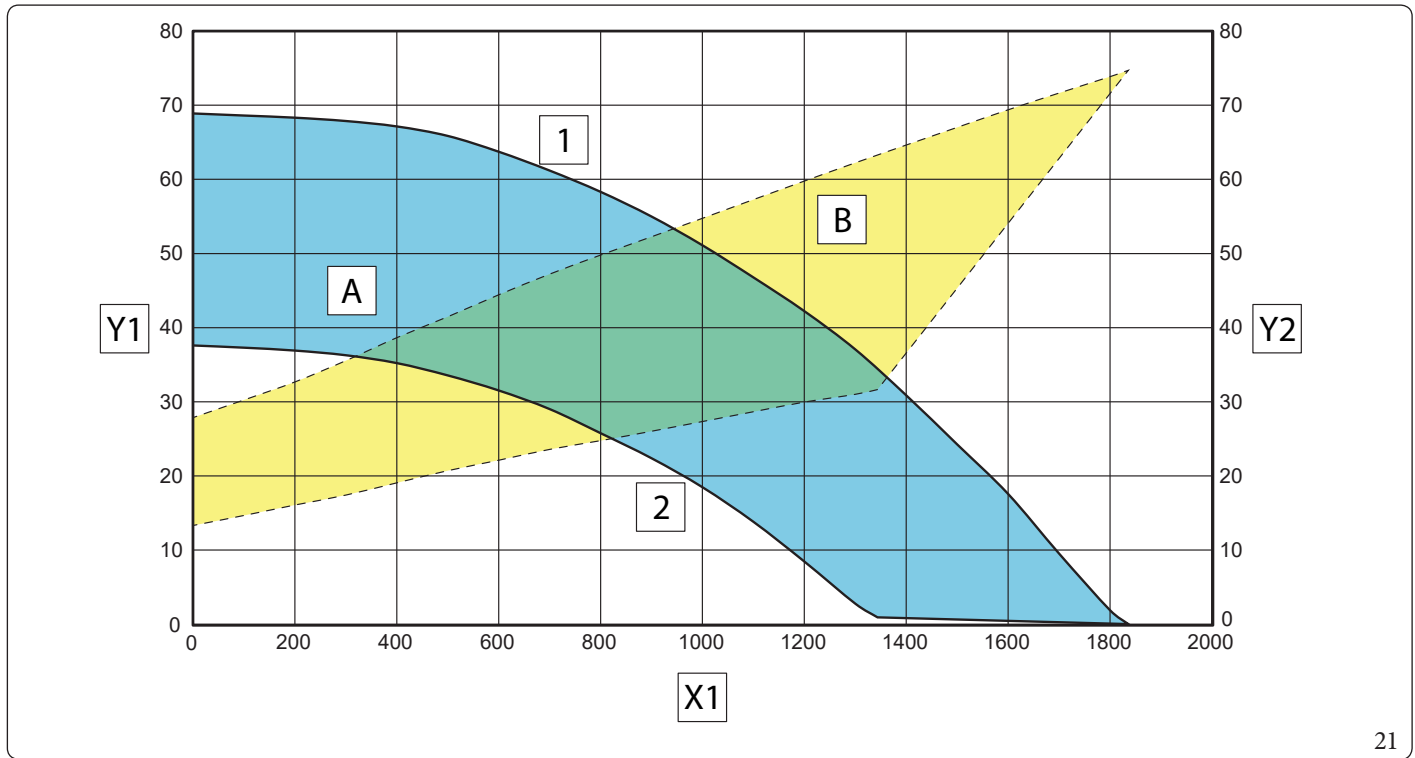

Key (Fig. 21):

- X1 = Flowrate (l/h)
- Y1 = Head (kPa)
- Y2 = Circulator pump absorbed power (W)
- 1 = Maximum speed (100%)
- 2 = Minimum speed (70%)
- A = Head available to the system
- B = Power absorbed by the circulator pump (dotted area)

1.22 KITS AVAILABLE ON REQUEST

- 3 kW heating system integrated resistance kit. Should it be necessary, you can install an electrical resistance to supplement the central heating system; this resistance can be installed directly inside the indoor unit.
- 2 zone kit (1 direct and 1 mixed). Should it be necessary, you can install the zone kit, which allows you to divide the heating system into two separate zones - one direct and one mixed.
- Configurable relay interface kit. The indoor unit is set up for a relay board, which amplifies the features and thus, the operating possibilities.
- 2-relay board kit. The indoor unit can manage up to two dehumidifiers. A 2 relay board that manages dehumidifier enabling is available to pair the appliances.
- R32 circuit connection kit. For R32 circuit wall connections, there is a kit with the two pipes necessary to create the circuit.



The above-mentioned kits are supplied complete with instructions for assembly and use. Check the complete list of kits available and which can be combined with the product, consult the Immergas website, the Immergas Price List or the technical-commercial documentation (catalogues and data sheets).

INSTALLER

USER

MAINTENANCE TECHNICIAN

TECHNICAL DATA

1.23 MAIN COMPONENTS

INSTALLER

USER

MAINTENANCE TECHNICIAN

TECHNICAL DATA

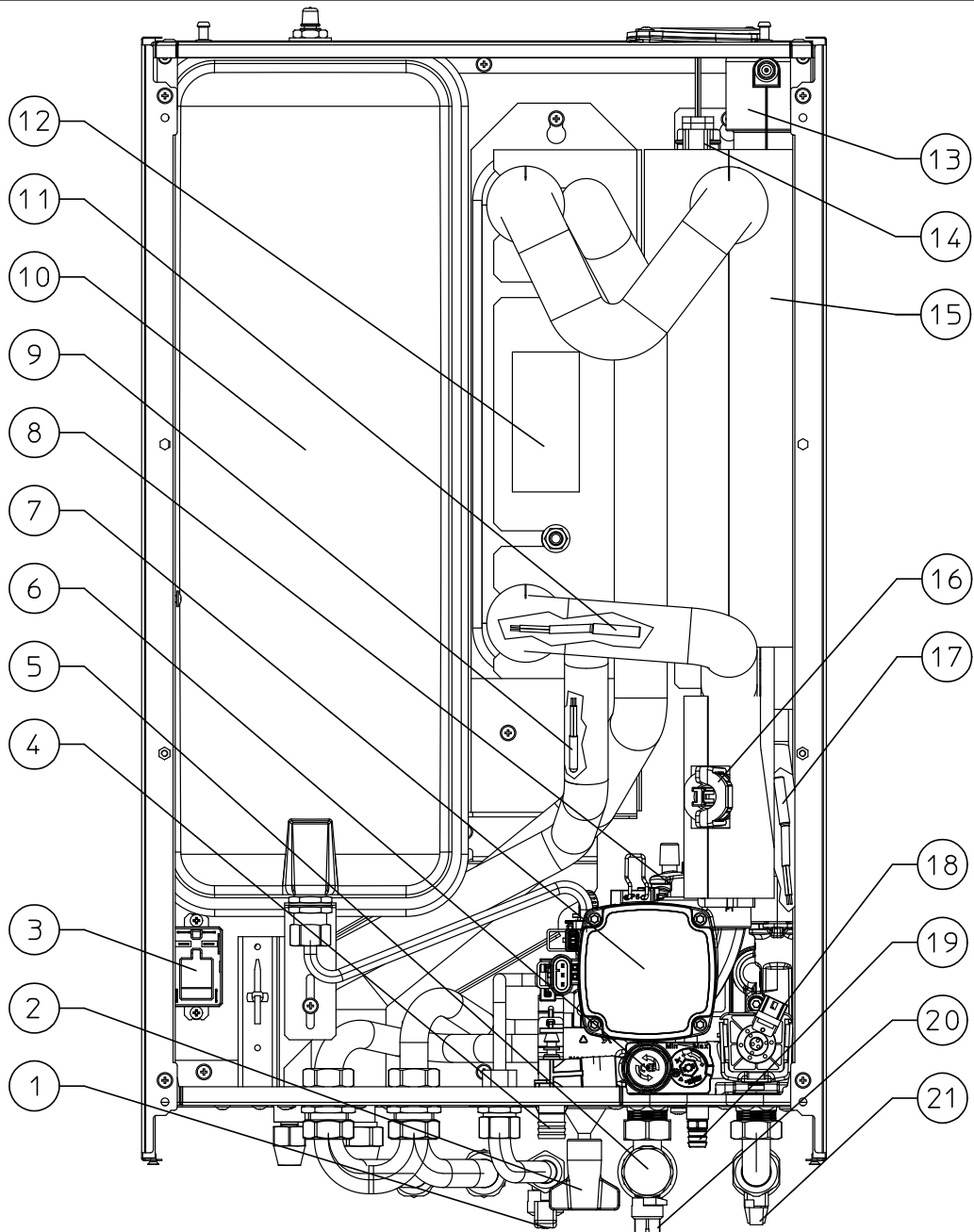

Key (Fig. 22):

- | | | | |
|----|------------------------------------|----|--|
| 1 | - Domestic hot water inlet cock | 13 | - Air vent valve |
| 2 | - System filling cock | 14 | - Heating system integrated electrical resistance cap (optional) |
| 3 | - Relay (optional) | 15 | - Central heating manifold |
| 4 | - 3-bar safety valve drain fitting | 16 | - System flow-meter |
| 5 | - Filter that can be inspected | 17 | - Return probe |
| 6 | - 3 bar safety valve | 18 | - 3-way valve (motorised) |
| 7 | - Pump | 19 | - System draining cock |
| 8 | - Air vent valve | 20 | - System shut-off cock |
| 9 | - Liquid phase detection probe | 21 | - System shut-off cock |
| 10 | - System expansion vessel | | |
| 11 | - Flow probe | | |
| 12 | - Plate heat exchanger | | |

22

2 INSTRUCTIONS FOR USE AND MAINTENANCE

2.1 GENERAL RECOMMENDATIONS



Never expose the indoor unit to direct vapours from a hob.



The device can be used by children at least 8 years old as well as by persons with reduced physical, sensory or mental capabilities, or lack of experience or required knowledge, provided that they are under surveillance, or after they have been instructed relating to the safe use and have understood the potential dangers.

Children must not play with the appliance.

Cleaning and maintenance destined to be performed by the user can not be carried out by unsupervised children.



If temporary shutdown of the indoor unit is required, proceed as follows:

- drain the heating system if antifreeze is not used;
- shut off the electrical and water supply.



Never clean the appliance or connected parts with easily flammable substances.



Never leave containers or flammable substances in the same environment as the appliance.



Do not open or tamper with the appliance.



Do not climb on the appliance, do not use the appliance as a support base.



Only use the user interface devices listed in this section of the booklet.



The use of components involving use of electrical power requires some fundamental rules to be observed such as:

- do not touch the appliance with wet or moist parts of the body; do not touch when barefoot;
- never pull electrical cables or leave the appliance exposed to atmospheric agents (rain, sunlight, etc.);
- the appliance power cable must not be replaced by the user;
- in the event of damage to the cable, switch off the appliance and contact exclusively qualified staff for replacement;
- if the appliance is not to be used for a certain period, disconnect the main indoor unit external switch.



(If paired with a storage tank unit) water at a temperature of more than 50 °C can cause serious burns.

Always check the water temperature before any use.



The temperatures indicated by the display have a tolerance of +/- 3°C due to environmental conditions that cannot be blamed on the indoor unit.



At the end of its service life, the appliance must not be disposed of like normal household waste nor abandoned in the environment, but must be removed by a professionally authorised company as required by current legislation. Contact the manufacturer for disposal instructions.

2.2 CLEANING AND MAINTENANCE



To preserve the system's integrity and keep the safety features, performance and reliability, which distinguish the assembly, unchanged over time, you must execute maintenance operations on a yearly basis in compliance with what is stated in the relative point at “annual check and maintenance of the appliance”, in compliance with national, regional, or local standards in force.

2.3 CONTROL PANEL

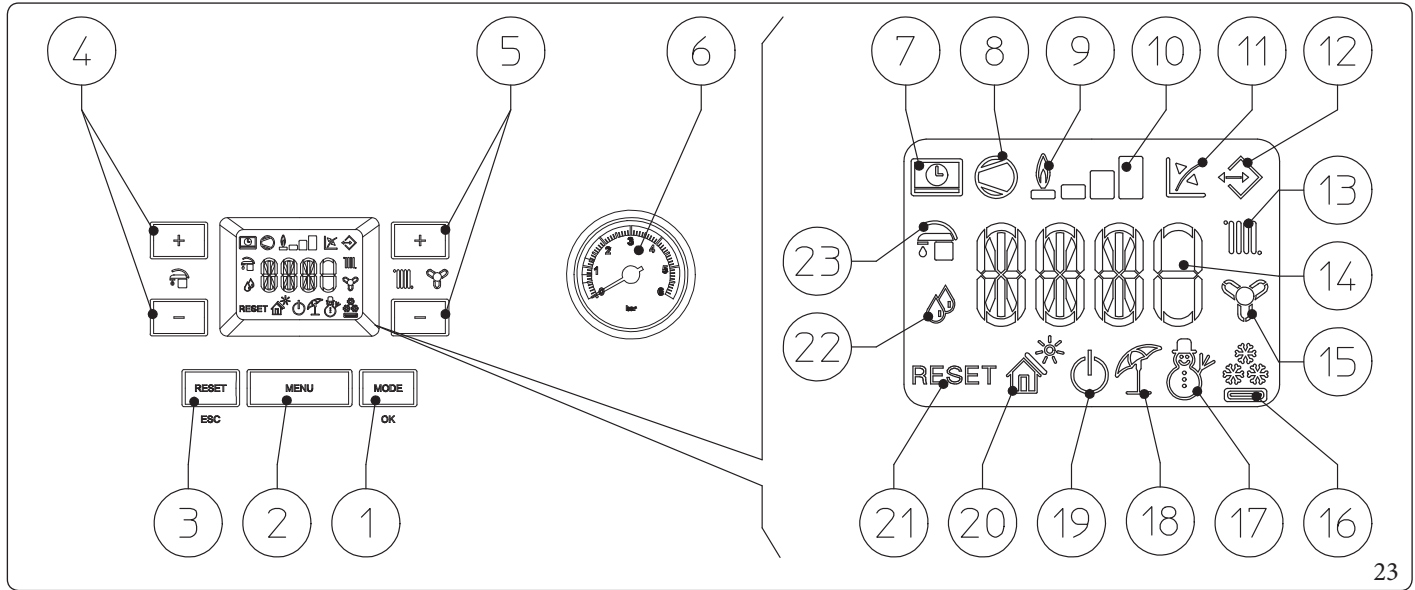

Key (Fig. 23):

- | | |
|--|--|
| <ul style="list-style-type: none"> 1 - Operating mode (winter - air conditioning - summer - stand-by - off) and parameter confirm button 2 - Menu selection button 3 - Reset and exit menu button 4 - Domestic hot water temperature selection buttons 5 - Heating system temperature selection buttons 6 - Indoor unit pressure gauge 7 - Remote control connection (optional) 8 - Outdoor unit in operation 9 - Not used on this model 10 - Dispensed output level 11 - Operation with external temperature probe active (optional) | <ul style="list-style-type: none"> 12 - Connection to other Immergas units 13 - Central heating room mode function active 14 - Temperature indicator, indoor unit info and error codes 15 - Room cooling mode operation active 16 - Operation in cooling mode 17 - Operation in winter mode 18 - Operation in summer mode 19 - Stand-by Mode 20 - Not used on this model 21 - Blocked indoor unit, it needs to be unblocked by pressing the "RESET" button 22 - Operation in dehumidification mode 23 - DHW production phase operating mode active |
|--|--|

2.4 SYSTEM USE



Before ignition, make sure the system is full of water, checking that the pressure gauge needle (6) points to a value between 1 and 1.2 bar and make sure that the chiller circuit has been filled as described in the outdoor unit instructions booklet.

- Press the button (1) until the display switches on. The system now goes back to the state prior to switch-off. (During ignition, the display shows in sequence: display segments all lit, parameter A011, parameter A013).
- If the indoor unit is in stand-by, press the button (1) again to activate it. If this is not the case, go to the next point.
- Then press the button (1) in sequence and set the system to summer ☀️, winter ❄️, or air conditioning position 🌬️.

Summer ☀️

In this mode, the system only works to produce domestic hot water, the temperature is set using the buttons (4) and the corresponding temperature is shown on the display by the indicator (14).

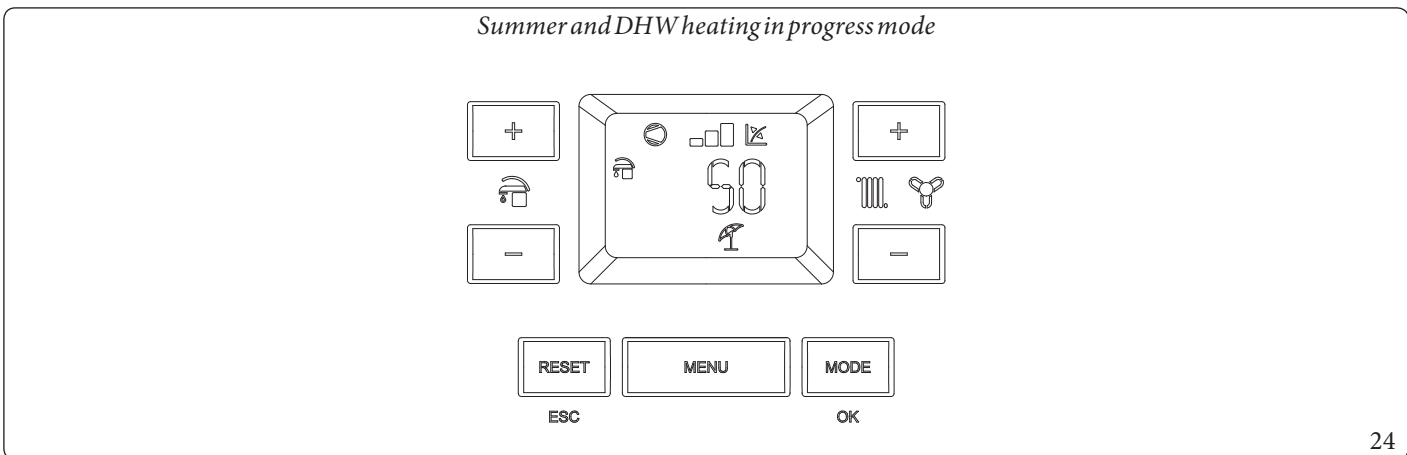

24

Winter ❄️

In this mode, the system works both to product domestic how water and room central heating.

The temperature of the DHW is always regulated via buttons (4), the central heating temperature is regulated via buttons (5) and the relative temperature is shown on the display by the indicator (14).

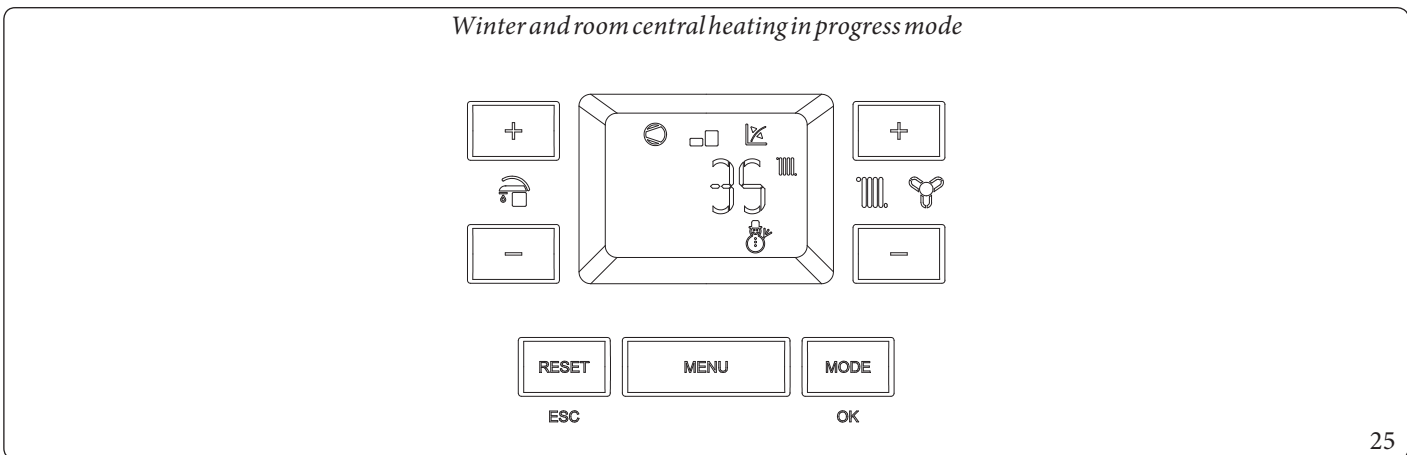

25

Air conditioning

In this mode, the system works both to produce DHW and to cool the room.

The temperature of the DHW is always regulated via buttons (4), the central heating temperature is regulated via buttons (5) and the relative temperature is shown on the display by the indicator (14).

From here on, the system works automatically. If there are no requests (room central heating, DHW production or cooling), the system goes into the “stand-by” function.

Each time the outdoor unit ignites, the display shows the corresponding symbol (8) with the corresponding power scale (10).

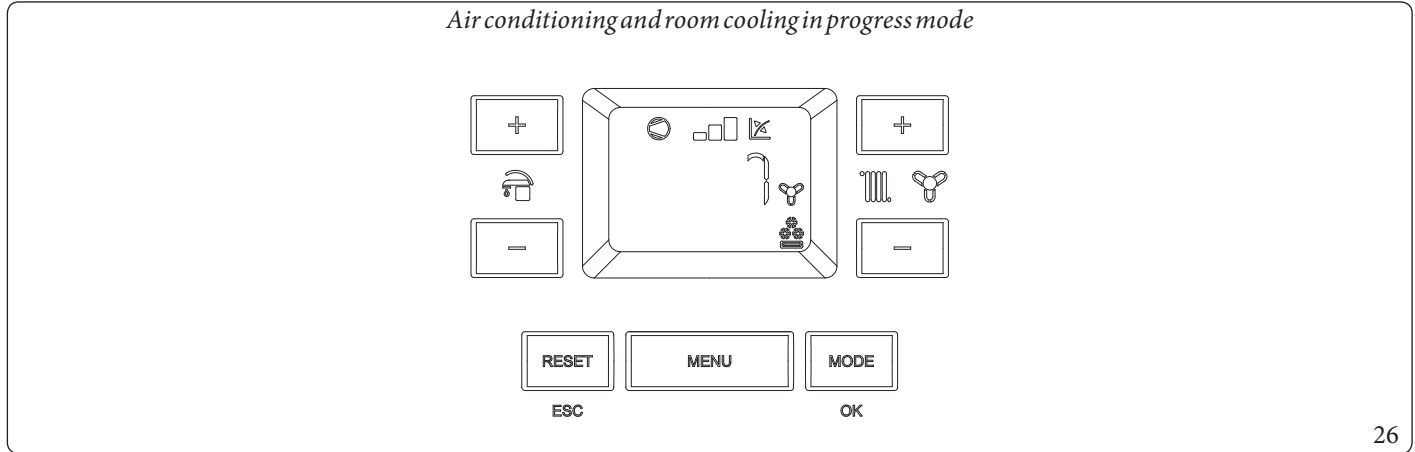

Operation with external probe

The system is set up to use the outdoor unit external probe or an optional external probe.

With the external probe connected, the system flow temperature for room heating and air conditioning is managed by the external probe based on the outdoor temperature measured (Parag. 1.15).

You can change the flow temperature by choosing the offset value in the specific user menu.

In this case, any settings made on the indoor unit will not affect system operation.

Dehumidify

If the system is coupled to a humidistat (optional) or a humidity temperature sensor or a remote zone panel (optional), you can manage the room humidity in summer air conditioning mode.

- If coupled to a humidistat, set the degree of humidity on the humidistat itself (see the instruction booklet).
- If coupled to a humidity temperature sensor, set the humidity percentage in the relative user menu.
- If coupled to a zone remote panel, set the humidity percentage in the relative user menu of the control panel or directly in the menu of the panel (see instruction booklet).

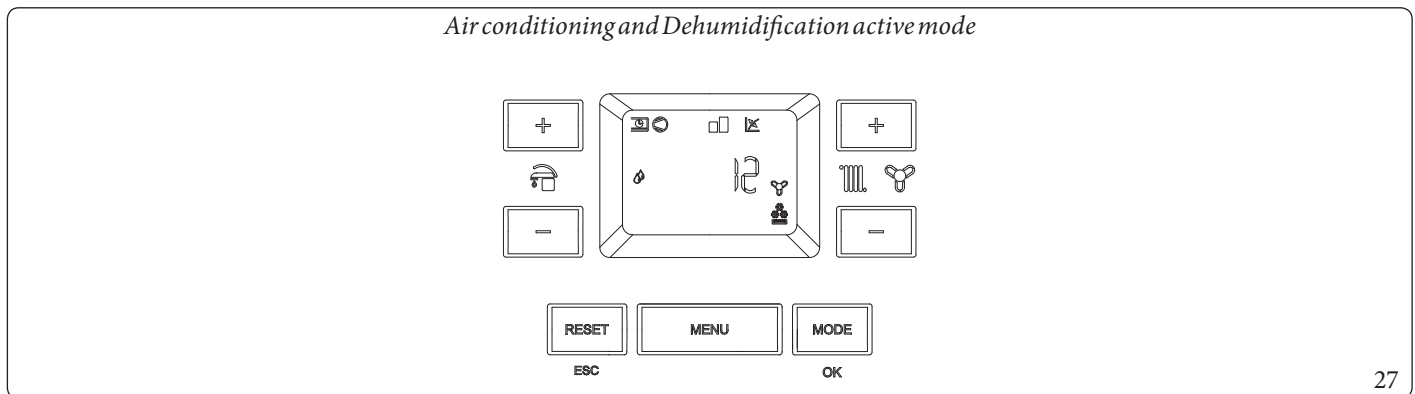

In central heating or cooling request mode, if the temperature of the water in the system meets the request, the system can work simply by activating the circulator pump.

“Stand-by” Mode

Press button (1) repeatedly until the symbol  appears. The system remains off from this moment, though the antifreeze, pump anti-block and 3-way function and signalling of any anomalies are guaranteed.



In these conditions the system must still be considered powered.

OFF mode

By holding the button (1) down for 8 seconds, the display switches-off and the indoor unit is off completely. In this mode, the safety functions are not guaranteed and the remote devices are disconnected.



In these conditions the indoor unit is considered still live even if there are no functions active.

“Automatic vent” mode

Every time the indoor unit is electrically powered, the system automatic vent function is activated (lasting 8 minutes). This function is displayed via a countdown signalled by the indicator (14).

During this period the DHW and CH functions are not active.

The “Automatic vent” function can be annulled by pressing the “Reset” button (3).

Display operation

The display lights up while the control panel is being used; after a set inactivity period, the brightness drops until only the active symbols are displayed. The lighting mode can be varied via parameter T08 in the P.C.B. programming menu.

System operating with outdoor unit disabled

You can disable the outdoor unit through a prearranged connection.

This status is signalled by the flashing of the symbol “Outdoor unit operation in progress” (8) and the flashing of the anomaly code “194”.



In this condition the requests are met by the integration electric resistances (optional).

2.5 FAULT AND ANOMALY SIGNALS

The indoor unit signals any anomalies by flashing a code on the display (14) according to the following table.

Error Code	Anomaly signalled	Cause	Indoor unit status/ Solution
E 5	Delivery probe fault	The board detects an anomaly on the flow NTC probe.	The system does not start (1).
E 8	Maximum N° of resets	Number of allowed resets already performed	Attention: the fault may be reset up to 5 times consecutively, after which the function is inhibited for at least one hour. One attempt is gained every hour for a maximum of 5 attempts. By switching the appliance on and off again, the 5 attempts are re-acquired.
E 12	Storage tank probe anomaly (optional)	The board detects an anomaly on the storage tank probe	The indoor unit cannot produce domestic hot water (1).
E 15	Configuration error	If the board detects an anomaly or incongruity on the electric wiring, the appliance will not start	If normal conditions are restored, the heat generator restarts without having to be reset (1).
E 24	Push button control panel anomaly	The board detects an anomaly on the pushbutton panel.	If normal conditions are restored, the system restarts without having to be reset (1).
E 26	System flowmeter anomaly	The board detects an anomaly on the system flowmeter. Booster pump, if any, always working.	The system does not start (1). Make sure the booster pump (optional) only activates when requested.
E 27	Circulation insufficient	This occurs if there is overheating in the indoor unit due to insufficient water circulating in the primary circuit; the causes can be: - low system circulation; check that no shut-off devices are closed on the central heating circuit and that the system is free of air (deaerated); - pump blocked; free the pump; - damaged flowmeter.	Check system circulation and flowmeter. Press the Reset button (1).
E 32	Mixed zone 2 probe anomaly	If the board detects an anomaly on the mixed zone 2 probe, the system cannot work in the affected area.	(1)
E 33	Mixed zone 3 probe anomaly	If the board detects an anomaly on the mixed zone 3 probe, the system cannot work in the affected area.	(1)
(1) If the shutdown or fault persists, contact an authorised company (e.g. Authorised After-Sales Technical Assistance Centre).			

INSTALLER

USER

MAINTENANCE TECHNICIAN

TECHNICAL DATA

Error Code	Anomaly signalled	Cause	Indoor unit status / Solution
E 34	Safety thermostat intervention Mixed zone 2	During normal operation, if an anomaly causes excessive overheating of the flow temperature in the mixed zone 2, the unit indicates the malfunction.	The unit does not meet the zone central heating requirement. (1)
E 35	Safety thermostat intervention Mixed zone 3	During normal operation, if an anomaly causes excessive overheating of the flow temperature in the mixed zone 3, the unit indicates the malfunction.	The unit does not meet the zone central heating requirement. (1)
E 37	Low power supply voltage	This occurs when the power supply voltage is lower than the allowed limits for correct system operation.	If normal conditions are restored, the system restarts without having to be reset (1)
E 46	Safety thermostat intervention zone 1	During normal operation, if an anomaly causes excessive overheating of the flow temperature in zone 1, the unit indicates the malfunction.	The unit does not meet the zone central heating requirement (1).
E 50	External probe missing or faulty	In the event the external probe is not connected or is faulty, the anomaly is indicated.	Check the external probe connection. The system continues to operate with the external probe integrated in the external unit (1). In case of replacement of the external probe, repeat the installation operations.
E 54	Central heating storage tank probe anomaly (optional)	The central heating storage tank has an out of range resistive value	Puffer mode is disabled. (1)
E 55	Mixed zone 1 probe anomaly	If the board detects an anomaly on the mixed zone 1 probe, the system cannot work in the affected area.	(1)
E 121	Zone 1 device offline alarm	The device connected to zone 1 is offline	(1)
E 122	Zone 2 device offline alarm	The device connected to zone 2 is offline	(1)
E 123	Zone 3 device offline alarm	The device connected to zone 3 is offline.	(1)
E 125	Zone 1 room temperature probe anomaly	The zone 1 room probe has an out of range resistive value	(1)
E 126	Zone 2 room temperature probe anomaly	The zone 2 room probe has an out of range resistive value	(1)

(1) If the shutdown or fault persists, contact an authorised company (e.g. Authorised After-Sales Technical Assistance Centre).

Error Code	Anomaly signalled	Cause	Indoor unit status/ Solution
E 127	Zone 3 room temperature probe anomaly	The zone 3 room probe has an out of range resistive value.	(1)
E 129	Zone 1 humidity probe anomaly	Anomaly on the zone 1 humidity probe.	In addition to the humidity, the dew point is not calculated for the zone either (1). Zone humidity cannot be checked.
E 130	Zone 2 humidity probe anomaly	Anomaly on the zone 2 humidity probe.	In addition to the humidity, the dew point is not calculated for the zone either (1). Zone humidity cannot be checked.
E 131	Zone 3 humidity probe anomaly	Anomaly on the zone 3 humidity probe.	In addition to the humidity, the dew point is not calculated for the zone either (1). Zone humidity cannot be checked.
E 138	Screed heater in progress	Screed heater function in progress.	(1).
E 139	De-aeration in progress	Deaeration function in progress	No demand can be made until the end of the function in progress (1)
E 142	Dominus offline alarm	Communication with Dominus is offline	(1)
E 177	DHW maximum time block	Domestic hot water production is not met within the pre-established time (see parameter P014)	The system continues to operate with non-optimal performance (1)
E 178	Anti-Legionella cycle block not successful	The anti-Legionella cycle is run without success within the pre-established time (see parameter P013)	Press the Reset button (1)
E 179	Liquid phase probe anomaly	The board detects an anomaly on the liquid phase NTC probe.	The system does not start (1).
E 182	Outdoor unit alarm	An anomaly appears on the outdoor unit	The system does not start (1).

(1) If the shutdown or fault persists, contact an authorised company (e.g. Authorised After-Sales Technical Assistance Centre).

INSTALLER

USER

MAINTENANCE TECHNICIAN

TECHNICAL DATA

Error Code	Anomaly signalled	Cause	Indoor unit status / Solution
E 183	Outdoor unit in test mode	A signal notifies that the condensing unit is in test mode	During this time, room air conditioning and domestic hot water production requirements cannot be met
E 184	Communication error with outdoor unit	A signal notifies an anomaly due to a communication problem between the indoor unit and the outdoor unit.	Have the electrical connection between the units checked. The system does not start (1).
E 187	Return probe anomaly	The board detects an anomaly on the return NTC probe	The system does not start (1).
E 188	Request with temperature out of range	A request is made with the outdoor temperature exceeding the operating limits (Parag. 1.18)	The system does not start (1). Wait for the outdoor unit to be restored within operating limits.
E 189	Time out alarm with communication board	If communication between the printed circuit boards is lost, an anomaly is signalled.	The system does not start (1). Check communication between the P.C.B. and the interface board.
E 190	Communication board alarm	An anomaly appears on the communication board	The system does not start (1).
E 193	Appliance in test mode	A signal notifies that the appliance is in test mode	The system continues operating properly.
E 194	Outdoor unit disabled	A signal notifies that the outdoor unit has been disabled through the appropriate input in the terminal board	The system continues operating properly.
E 195	Liquid phase probe low temperature anomaly	Too low temperature is detected in the liquid phase	Check that the cooling circuit is working properly (1).
E 196	Flow high temperature block	An excessively high temperature is detected on the heat pump flow circuit	Check the hydraulic circuit (1).
E 197	Interface Board Configuration Error	An incorrect interface board configuration has been detected	The system does not start (1).

(1) If the shutdown or fault persists, contact an authorised company (e.g. Authorised After-Sales Technical Assistance Centre).

List of outdoor unit anomalies

If the outdoor unit is faulty, the error code is signalled on the control panel (Fig. 23) and on the interface board (see paragraph "Interface board - 7-segment display"). The failure is signalled in different ways.

On the control panel, the error is displayed with an "A" + error code.

On the interface board, the error is displayed with an "E" + error code, showing a sequence of two digits.

For example:

Error 101 is displayed as follows: E1 alternated with 01.

The following is the list of alarms as displayed on the control panel.

Error Code	Anomaly signalled	Indoor unit status/ Solution
A101	Outdoor unit communication error	Check the communication cable to the outdoor unit. Check that the interface board works properly. (1)
A109	Communication error due to incorrect address of interface board	Check the address on the interface board. (1)
A122	MODBUS communication error	Check communication between the management board and interface boards. (1)
A162	EEPROM error	Replace the main board of the outdoor unit (1)
A177	Emergency error	(1)
A198	Error of thermal fuse terminal board (open)	(1)
A201	Communication error (failed coupling) between interface board and outdoor unit	Check the communication cable to the outdoor unit. Check that the interface board and main board of the outdoor unit work properly (1)
A202	Communication error (failed coupling) between indoor unit and interface board	Check the communication cable to the outdoor unit. Check that the interface board and main board of the outdoor unit work properly (1)
A203	Communication error between Inverter and main board of the outdoor unit	Check wiring of communication between the two boards. Replace the main board. Replace the inverter board (1)
A221	Outdoor unit air temperature sensor error	Check the position of the sensor. Check the relative wiring Replace the sensor (1)
A231	Condenser temperature sensor error	Check the position of the sensor. Check the relative wiring Replace the sensor (1)
A251	Discharge temperature sensor error	Check the position of the sensor. Check the relative wiring Replace the sensor

(1) If the shutdown or fault persists, contact an authorised company (e.g. Authorised After-Sales Technical Assistance Centre).

Error Code	Anomaly signalled	Indoor unit status/ Solution
A320	Compressor sensor error (overload protection sensor)	Check the position of the sensor. Check the relative wiring Replace the sensor (1)
A403	Freezing detection (during cooling operation)	Check the chiller cycle. Check the temperatures of the plate heat exchanger (1)
A404	Protection of outdoor unit when in overload (during safety start-up, normal operating status)	Check the chiller cycle. Check the compressor connections. Check the resistances between the different phases of the compressor (1)
A407	Compressor not working due to high pressure	Check the chiller cycle (1)
A416	The compressor discharge is overheated	(1)
A430	Outdoor unit EEV operation error	(1)
A425	Not used on this model	(1)
A440	Central heating blocked (outdoor temperature beyond 35°C)	(1)
A441	Cooling blocked (outdoor temperature below 9°C)	(1)
A458	Error of outdoor unit fan no.1	(1)
A461	Compressor start-up error (Inverter)	Check the chiller cycle. Check the compressor connections. Check the resistances between the different phases of the compressor (1)
A462	Inverter total current overload error	Check the inlet current. Check the refrigerant charge. Check normal operation of the fan. (1)
A463	Compressor overheated sensor	Check the compressor sensor. (1)
A464	Inverter IPM current overload error	Check the compressor connections and its normal operation. Check the refrigerant charge. Check whether there are obstacles around the outdoor unit. Check whether the service valve is open. Check whether the installation pipes are mounted properly. (1)

(1) If the shutdown or fault persists, contact an authorised company (e.g. Authorised After-Sales Technical Assistance Centre).

Error Code	Anomaly signalled	Indoor unit status/ Solution
A465	Compressor overload error	Check the compressor connections and its normal operation. Check the resistances between the different phases of the compressor. (1)
A466	Low voltage error of DC circuit	Check the input voltage. Check the power connections. (1)
A467	Compressor rotation error	Check the compressor connections. Check the resistances between the different phases of the compressor. (1)
A468	Current sensor error (inverter)	Check the main board. (1)
A469	Voltage sensor error of DC circuit (inverter)	Check the power connector of the inverter board. Check the connectors RY21 and R200 of the inverter board. (1)
A470	EEPROM reading/writing error of outdoor unit	Check the main board. (1)
A471	EEPROM reading/writing error of outdoor unit	Check the main board. (1)
A474	Inverter temperature sensor error	Replace inverter board (1)
A475	Error of outdoor unit fan no.2 (where present)	Check the wiring. Check that the fan is powered. Check the board fuses. (1)
A484	PFC overload	Check inductances. Replace inverter board. (1)
A485	Incoming current sensor error	Replace inverter board. (1)
A500	IPM overheated	Check temperature of inverter board. Switch the machine off. Wait for the inverter to cool down. Switch the machine back on. (1)
A554	Gas leak error	Check that the coolant is charged Check the liquid sensor of the indoor unit Check whether the service valve is open Check whether the installation pipes are mounted properly. (1)
A590	Inverter board error	Check normal operation of the main board. Replace the main board (1)
A601	Not present	(1)

(1) If the shutdown or fault persists, contact an authorised company (e.g. Authorised After-Sales Technical Assistance Centre).

INSTALLER

USER

MAINTENANCE TECHNICIAN

TECHNICAL DATA

Error Code	Anomaly signalled	Indoor unit status/ Solution
A604	Not present	(1)
A653	Not present	(1)
A654	Not present	(1)
A899	Not present	(1)
A900	Not present	(1)
A901	Not used	Indoor unit error Check indoor unit (1)
A902	Not used	Indoor unit error Check indoor unit (1)
A903	Not used	Indoor unit error Check indoor unit (1)
A904	Not used	Indoor unit error Check indoor unit (1)
A906	Not used	Indoor unit error Check indoor unit (1)
A911	Not used	Indoor unit error Check indoor unit (1)
A912	Not used	Indoor unit error Check indoor unit (1)
A916	Not used	Indoor unit error Check indoor unit (1)
A919	Not used	Indoor unit error Check indoor unit (1)

(1) If the shutdown or fault persists, contact an authorised company (e.g. Authorised After-Sales Technical Assistance Centre).

2.6 PARAMETERS AND INFORMATION MENU

Pressing the “MENU” button (2), the display cyclically shows the “Data” menu, “User” menu and a menu protected by a “0000” access code with the first flashing digit reserved for a qualified technician.

To access an individual menu, once it appears, press the “OK” button (1).

To scroll through the menu items and to edit the values, use the heating temperature control buttons (5). Pressing the “OK” button (1) confirms the parameter, while pressing the “ESC” button (3) goes back to the previous menu or exits.

A minute after the last operation, the system automatically exits any of the menus.



The menus of the control panel, found in the booklet, refer to rev. 6.0 of the P.C.B. firmware.

Data Menu.

Parameter ID	Description	Range
D 03	Storage tank unit temperature (if paired with a storage tank unit)	-10 ÷ 130 °C
D 04	Value calculated for system setting	5 ÷ 65 °C
D 05	Set value for the DHW set (if paired with a storage tank unit)	10 ÷ 65 °C
D 06	Outdoor temperature (if the outdoor unit external probe is connected or if the optional external probe is available)	-20 ÷ 50 °C
D 08	System return water temperature	-10 ÷ 130 °C
D 09	List of the last five anomalies (to scroll the list press “OK” (1)).	-
D 10	Anomaly list reset. Once “D 10” is displayed, press “OK”.	-
D 14	Circulator pump flow rate	0 ÷ 9999
D 17	Zone 1 flow temperature (if configured)	0 ÷ 99 °C
D 20	System flow temperature	-10 ÷ 130 °C
D 22	DHW 3-way (DHW = domestic hot water, CH = central heating) (if paired with a storage tank unit)	DHW - CH
D 24	Chiller circuit liquid temperature	-10 ÷ 130 °C
D 25	Zone 2 flow temperature (if configured)	-10 ÷ 130 °C
D 26	Probe for primary solar storage (puffer)	-10 ÷ 130 °C
D 28	System circulator pump instantaneous speed	0 ÷ 100 %
D 31	DHW integration function (if paired with a storage tank unit)	OFF - ON
D 32	System integration function	OFF - ON
D 34	Heat pump disabling	OFF - ON
D 35	Solar system inlet	OFF - ON
D 41	Relative humidity zone 1 (if zone 1 humidity sensor active)	0 ÷ 99 %
D 42	Relative humidity zone 2 (if zone 2 humidity sensor active)	0 ÷ 99 %
D 43	Zone 1 humidistat (if zone 1 humidistat active)	OFF - ON
D 44	Zone 2 humidistat (if zone 2 humidistat active)	OFF - ON
D 45	Dehumidifier zone 1	OFF - ON
D 46	Dehumidifier zone 2	OFF - ON
D 47	Zone 1 circulator pump	OFF - ON
D 48	Zone 2 circulator pump	OFF - ON
D 49	Central heating / cooling system separation 3-way (CL = cooling, HT = heating)	CL - HT
D 51	Zone 1 remote panel	OFF - ON
D 52	Zone 2 remote panel	OFF - ON

Parameter ID	Description	Range
D 53	System setting with remote connection in zone 1	5 ÷ 65 °C
D 54	System setting with remote connection in zone 2	5 ÷ 65 °C
D 55	Zone 1 thermostat	OFF - ON
D 56	Zone 2 thermostat	OFF - ON
D 61	System model definition (MP = Magis Pro V2; MCI = Magis Combo V2; MCP = Magis Combo Plus V2)	MP - MCI - MCP
D 62	Communication with interface board	OFF - ON
D 63	Communication with other Immergas devices	OFF - ON
D 71	External unit operating frequency	0 ÷ 150 Hz
D 72	Compressor temperature	-20 ÷ 200 °C
D 73	Compressor discharge temperature	-20 ÷ 100 °C
D 74	Evaporator coil temperature	-20 ÷ 100 °C
D 75	Outdoor unit compressor absorption (make sure the value reading refers to the inverter and therefore not a value read with an amperometric clamp).	0 ÷ 10 A
D 76	Outdoor unit fan speed	0 ÷ 100 rpm
D 77	Electronic expansion valve position	0 ÷ 2000
D 78	4-way side (CL = cooling, HT = heating)	HT / CL
D 79	Temperature detected by the external probe of the outdoor unit	-55 ÷ +45 °C
D 80	Heat pump status (reserved for Authorised After-Sales Technical Assistance Centre)	-
D 91	P.C.B. software version	1 ÷ 99
D 97	Heat pump demand status (reserved to Authorised After-Sales Technical Assistance Centre)	0 ÷ 999
D 98	Thermal generator demand status (reserved for Authorised After-Sales Technical Assistance Centre)	0 ÷ 999
D 99	System status (reserved for Authorised After-Sales Technical Assistance Centre)	0 ÷ 999
D101	Zone 3 flow temperature	1 ÷ 99
D102	Zone 3 relative humidity	1 ÷ 99
D103	Zone 3 humidistat	OFF - ON
D104	Dehumidifier zone 3	OFF - ON
D105	Zone 3 circulator pump	OFF - ON
D106	Zone 3 remote panel	OFF - ON
D107	Zone 3 setpoint	5 ÷ 55
D108	Zone 3 thermostat	OFF - ON
D120	Outdoor unit main board firmware version (1/4)	1 ÷ 99
D121	Outdoor unit main board firmware version (2/4)	1 ÷ 99
D122	Outdoor unit main board firmware version (3/4)	1 ÷ 99
D123	Outdoor unit main board firmware version (4/4)	1 ÷ 99
D124	Interface board firmware version (1/4)	1 ÷ 99
D125	Interface board firmware version (2/4)	1 ÷ 99
D126	Interface board firmware version (3/4)	1 ÷ 99

Parameter ID	Description	Range
D127	Interface board firmware version (4/4)	1 ÷ 99
D128	Outdoor unit inverter board memory version (1/4)	1 ÷ 99
D129	Outdoor unit inverter board memory version(2/4)	1 ÷ 99
D130	Outdoor unit inverter board memory version (3/4)	1 ÷ 99
D131	Outdoor unit inverter board memory version (4/4)	1 ÷ 99
D132	Outdoor unit inverter board firmware version (1/4)	1 ÷ 99
D133	Outdoor unit inverter board firmware version (2/4)	1 ÷ 99
D134	Outdoor unit inverter board firmware version (3/4)	1 ÷ 99
D135	Outdoor unit inverter board firmware version (4/4)	1 ÷ 99
D140	Internal clock	0 ÷ 23
D141	Internal clock	0 ÷ 59
D142	Day of the week	Mo-Tu-We-Th-Fr-Sa-Su
D143	Current day	1 ÷ 31
D144	Current month	1 ÷ 12
D145	Current year	0 ÷ 99

INSTALLER

USER

MAINTENANCE TECHNICIAN

TECHNICAL DATA

User Menu.

Parameter ID	Description		Range	Default	Customised value
U 01	Zone 2 heating flow set point in case of no thermal regulation ("R 01" = OFF).		20 ÷ 65 °C	25	
U 02	Zone 2 cooling flow set point in case of no thermal regulation ("R 01" = OFF)		5 ÷ 25 °C	20	
U 03	Zone 1 central heating offset	It is possible to correct the flow temperature with respect to the adjustment curve of the external probe in central heating mode (Parag. 1.16, Offset value)	- 15 ÷ + 15 °C	0	
U 04	Zone 2 central heating offset		- 15 ÷ + 15 °C	0	
U 05	Zone 1 cooling offset	The flow temperature with respect to the adjustment curve of the external probe in cooling mode can be corrected (Parag. 1.16, Offset value)	- 15 ÷ + 15 °C	0	
U 06	Zone 2 cooling offset		- 15 ÷ + 15 °C	0	
U 07	Zone 1 humidity setting	The humidity temperature sensor (optional) defines room humidity in the corresponding area	30 ÷ 70 %	50	
U 08	Zone 2 humidity setting		30 ÷ 70 %	50	
U 11	Night function	Activating the function allows you to reduce the compressor frequency during the outdoor unit operation in the time slot set in the U 12 and U 13 parameters. Make sure the additional power sources needed to meet potential requirements that may present themselves during active operation are available (e.g. additional resistances)	OFF - ON	OFF	
U 12	Night function enabling time		0 ÷ 23	0	
U 13	Night function disabling time		0 ÷ 23	0	
U 14	Zone 3 heating flow set point in case of no thermal regulation ("R 01" = OFF).		20 ÷ 65 °C	25	
U 15	Zone 3 cooling flow set point in case of no thermal regulation ("R 01" = OFF)		5 ÷ 25 °C	20	
U 16	Zone 3 central heating offset.	It is possible to correct the flow temperature with respect to the adjustment curve of the external probe in central heating mode (Parag. 1.16, Offset value)	- 15 ÷ + 15 °C	0	
U 17	Zone 3 cooling offset.		- 15 ÷ + 15 °C	0	
U 18	Zone 3 humidity setting.	The humidity temperature sensor (optional) defines room humidity in the corresponding area	30 ÷ 70	50	

Parameter ID	Description		Range	Default	Customised value
U 21	Hour setting (internal clock)		0 - 23 hours	-	
U 22	Minutes setting (internal clock)		0 - 59 minutes	-	
U 23	Day of the week		Mo-Tu-We- Th-Fr-Sa-Su	-	
U 24	Current day		1 ÷ 31	-	
U 25	Current month		1 ÷ 12		
U 26	Current year		00 ÷ 99		
U 32	Start time of the DHW recirculation.		0 ÷ 23	0	
U 33	Stop time of the DHW recirculation.		0 ÷ 23	0	
U 50	Venting	In the case of new central heating systems and in particular mode for floor systems, it is very important that de-aeration is performed correctly. The function consists of the cyclic activation of the pump (100 s ON, 20 s OFF) and the 3-way valve (120 s D.H.W., 120 s heating system). The function lasts for 18 hours and it is possible to stop it by pressing "ESC" and setting the function on "OFF". Activation of the function is signalled by the countdown shown on the indicator (14).	OFF - ON	OFF	



The parameters referring to zone 2 can only be displayed if there is a zone 2 on the system and it is configured correctly.



The parameters referring to zone 3 can only be displayed if there is a zone 3 on the system and it is configured correctly.

2.7 INDOOR UNIT SHUTDOWN

Switch off the indoor unit, putting it in "OFF" mode. Switch off the omni-polar switch outside the unit. Never leave the unit powered if left unused for prolonged periods.

2.8 RESTORE CENTRAL HEATING SYSTEM PRESSURE

1. Periodically check the system water pressure (the indoor unit's pressure gauge hand must indicate a value between 1 and 1.2 bar).
2. If the pressure is less than 1 bar (with the system cold), you must restore it using the cock located at the bottom of the unit (Parag. 1.23).
3. Close the cock after the operation.
4. If the pressure reaches values around 3 bar, there is a risk of tripping the safety valve (in this case, remove water from a radiator air vent valve until a pressure of 1 bar is achieved, or ask for assistance from professionally qualified personnel).
5. In the event of frequent pressure drops, contact qualified staff for assistance to eliminate the possible system leakage.

2.9 DRAINING THE SYSTEM

1. Ensure that the filling cock is closed.
2. Open the draining cock (Parag. 1.23).
3. Open all vent valves.
4. At the end, close the emptying cock.
5. Close all previously opened vent valves.



If fluid containing glycol was added to the system circuit, make sure it is recovered and disposed of in accordance with standard EN 1717.

2.10 ANTIFREEZE PROTECTION

The indoor unit has an anti-freeze function that automatically switches on the outdoor unit when the temperature drops below 4°C (standard protection up to a minimum temperature of -5°C).

All information relative to the antifreeze protection is stated in (Parag. 1.5).

In order to guarantee the integrity of the appliance and the domestic hot water heating system (if paired with a storage tank unit) in areas where the temperature drops below zero, we recommend protecting the central heating system using anti-freeze liquid and installing the Immergas Antifreeze Kit in the indoor unit.

2.11 PROLONGED INACTIVITY

In case of prolonged inactivity (e.g. second home), we recommend:

1. to switch off the power supply;
2. completely empty the central heating circuit and the indoor unit domestic hot water circuit (if paired with a storage tank unit). In systems that are drained frequently, filling must be carried out with suitably treated water to eliminate hardness that can cause lime-scale.

2.12 CLEANING THE CASE

1. Use damp cloths and neutral detergent to clean the indoor unit casing.



Never use abrasive or powder detergents.

2.13 PERMANENT SHUTDOWN

Should the system be shut down permanently, have professional staff carry out the procedures, making sure that the electrical and water supply lines have been previously shut off.

2.14 USE OF THE REMOTE ZONE PANEL (OPTIONAL)

For general operation of the zone remote panel, see the relative instruction booklet.

The settings on the remote panel, such as operating mode, flow setting, humidity setting etc. are synchronised with those on the machine control panel.

Moreover, the control panel is not disabled if there is any zone remote panel.

Using a Zone Remote Panel with firmware version 2.00 or higher, it is possible to:

- edit the DHW setpoint;
- read the domestic hot water temperature;
- remotely reset the errors that appear;
- set the flow setpoint and offset from the Zone Setpoint Menu;
- set Eco, Comfort and manual DHW (Domestic hot water) setpoint from the DHW (Domestic hot water) Setpoint Menu;
- enable and configure the DHW time slots;
- read information on flow and return of the enabled generators;
- set the minimum central heating setpoint.

The parameters that are not managed by the appliance will be displayed on the Zone Remote Panel with the symbol "--".

3 INSTRUCTIONS FOR MAINTENANCE AND INITIAL CHECK

3.1 GENERAL RECOMMENDATIONS



**Operators who install and service the appliance must wear the personal protective equipment (PPE) required by applicable law.
The list of possible PPE is not complete as they are indicated by the employer.**



Before carrying out any maintenance work, make sure that:
– you have disconnected the power to the appliance;
– you have discharged the pressure from the system and domestic hot water circuit.



Supply of spare parts

The device's warranty shall be rendered null and void if unapproved or unsuitable parts are used for maintenance or repairs. These will also compromise the product's compliance, and the said product may no longer be valid and fail to meet the current regulations. In regard to the above, only use original Immergas spare parts when replacing components.



If additional documentation needs to be consulted for extraordinary maintenance, contact the Authorised After-Sales Service.



**The appliance operates with R32 refrigerant gas.
This gas is ODOURLESS.
Pay the utmost attention
Strictly follow the instruction handbook of the Audax Pro V2 outdoor condensing unit before installation and any type of operation on the cooling line.**



R32 refrigerant gas belongs to the low flammability refrigerant category: class A2L according to standard ISO 817. It guarantees high performance with low environmental impact. The new gas reduces the potential environmental impact by one third compared to R410A, having less effect on global warming (GWP 675).

INSTALLER

USER

MAINTENANCE TECHNICIAN

TECHNICAL DATA

3.2 INITIAL CHECK

To commission the package, you must:

- check connection to a 230V-50Hz power mains, correct L-N polarity and the earthing connection;
- make sure the central heating system is filled with water and the indoor unit pressure gauge reads a pressure of 1-1.2 bar;
- make sure the chiller circuit has been filled according to what is described in the outdoor unit instructions booklet;
- check the activation of the main switch located upstream of the indoor unit;
- ensure activation of all adjustment devices;
- check the production of DHW (if paired with a storage tank unit);
- check the tightness of the hydraulic circuits;



Even if just one single safety check provides a negative result, do not commission the system.

3.3 YEARLY APPLIANCE CHECK AND MAINTENANCE



The following checks and maintenance should be performed once a year to ensure operation, safety and efficiency of the appliance over time.

- Check for water leaks or oxidation from/on the fittings.
- Check, after discharging the system pressure and bringing it to zero (read on indoor unit pressure gauge), that the expansion vessel charge is at 1.0 bar.
- Check that the system static pressure (with system cold and after refilling the system by means of the filling valve) is between 1 and 1.2 bar.
- Visually check that the safety and control devices have not been tampered with and/or short-circuited.
- Check the condition and integrity of the electrical system and in particular:
 - the power supply wires must be housed in the cable glands;
 - there must be no traces of blackening or burning.
- Check correct lighting and operation.
- Check correct operation of control and adjustment devices and in particular:
 - system regulation probes intervention.
 - Check chiller line connections.
 - Check mesh filter on system return.
 - Check the correct flow rate on plate heat exchanger.
 - Check the integrity of the internal insulation.



In addition to yearly maintenance, one must also check the energy efficiency of the thermal system, with frequency and procedures that comply with the indications of the technical regulations in force.

3.4 COIL MAINTENANCE



We recommend regularly inspecting the finned air coils to check the level of fouling.

This depends on the environment where the unit is installed.

The level of fouling will be worse in urban and industrial sites, as well as near trees that lose their leaves.

There are two maintenance levels to clean the coils:

- If the air heat exchangers are encrusted, clean them gently with a brush in a vertical direction.
- Turn off the fans before working on the air heat exchangers.
- To perform this type of intervention, stop the unit only if the maintenance considerations allow it.
- Perfectly clean air heat exchangers ensure an optimal operation of the unit. When the air heat exchangers begin to encrust, they must be cleaned. The cleaning frequency depends on the season and location of the unit (ventilated, wooded, dusty, etc.).
- Do not use pressurised water without a large diffuser. Do not use high-pressure cleaners for Cu/Cu and Cu/Al air coils.
- Concentrated and/or rotating water jets are strictly prohibited. Never use fluid with a temperature above 45°C to clean the air heat exchangers.
- Proper and frequent cleaning (approx. every three months) prevents 2/3 of corrosion problems.

Clean the air coil using suitable products.

INSTALLER

USER

MAINTENANCE TECHNICIAN

TECHNICAL DATA

3.5 HYDRAULIC DIAGRAM

INSTALLER

USER

MAINTENANCE TECHNICIAN

TECHNICAL DATA

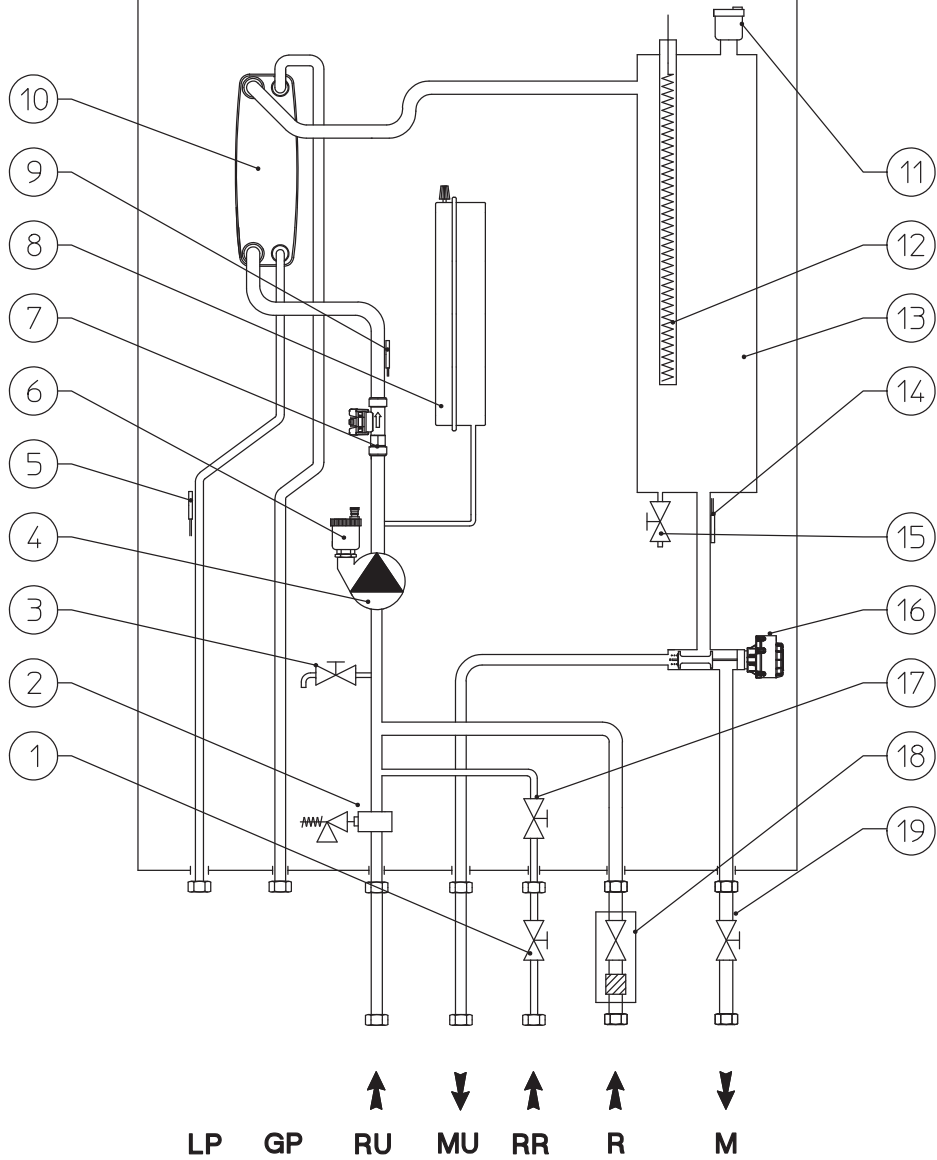

Key (Fig. 28):

- | | |
|--|--|
| 1 - System shut-off cock | 14 - Flow probe |
| 2 - 3 bar safety valve | 15 - System draining cock |
| 3 - System draining cock | 16 - 3-way valve (motorised) |
| 4 - Pump | 17 - System filling cock |
| 5 - Liquid phase detection probe | 18 - System shut-off fitting with filter |
| 6 - Air vent valve | 19 - System shut-off cock |
| 7 - System flow-meter | |
| 8 - System expansion vessel | LP - Chiller line - liquid phase |
| 9 - Return probe | GP - Chiller line - gaseous phase |
| 10 - Plate heat exchanger | RU - Storage tank unit return |
| 11 - Air vent valve | MU - Storage tank unit flow |
| 12 - Central heating integrated electric resistance (optional) | RR - System filling |
| 13 - Central heating manifold | R - System return |
| | M - System flow |

3.6 WIRING DIAGRAM

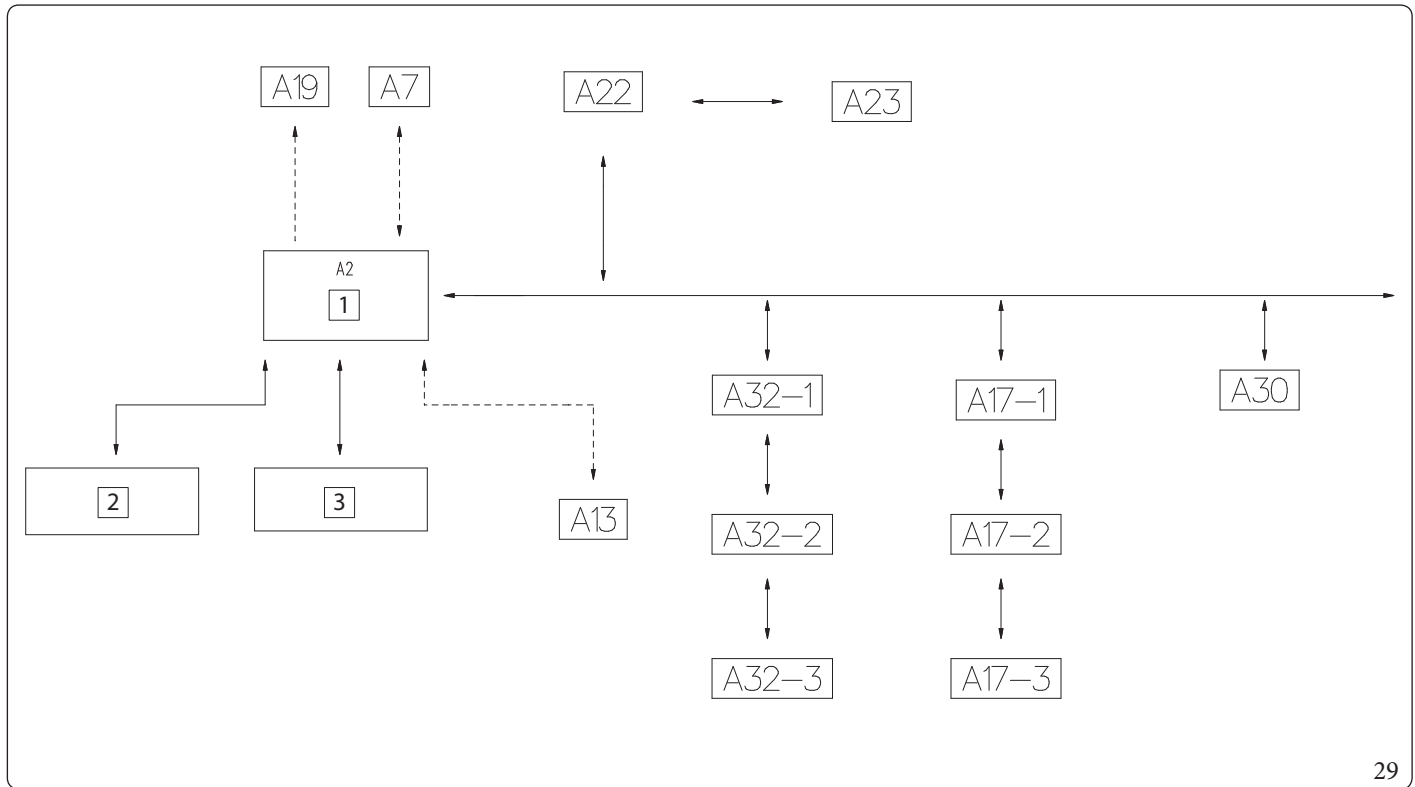

INSTALLER

USER

29

Key (Fig. 29):

- 1 - P.C.B.
- 2 - Low voltage electrical connection clamps (230 Vac)
- 3 - Very low safety voltage electrical connection clamps
- A2 - P.C.B.
- A7 - Three-relay board (optional)
- A13 - System manager (optional)
- A17-1 - Modbus zone 1 temp./humidity probe (optional)
- A17-2 - Modbus zone 2 temp./humidity probe (optional)

- A17-3 - Modbus zone 3 temp./humidity probe (optional)
- A19 - Two-relay board (optional)
- A22 - Interface board
- A23 - External unit
- A30 - Dominus (optional)
- A32-1 - Zone 1 remote control (optional)
- A32-2 - Zone 2 remote control (optional)
- A32-3 - Zone 3 remote control (optional)

MAINTENANCE/TECHNICIAN

TECHNICAL DATA

TECHNICAL DATA

MAINTENANCE TECHNICIAN

USER

INSTALLER

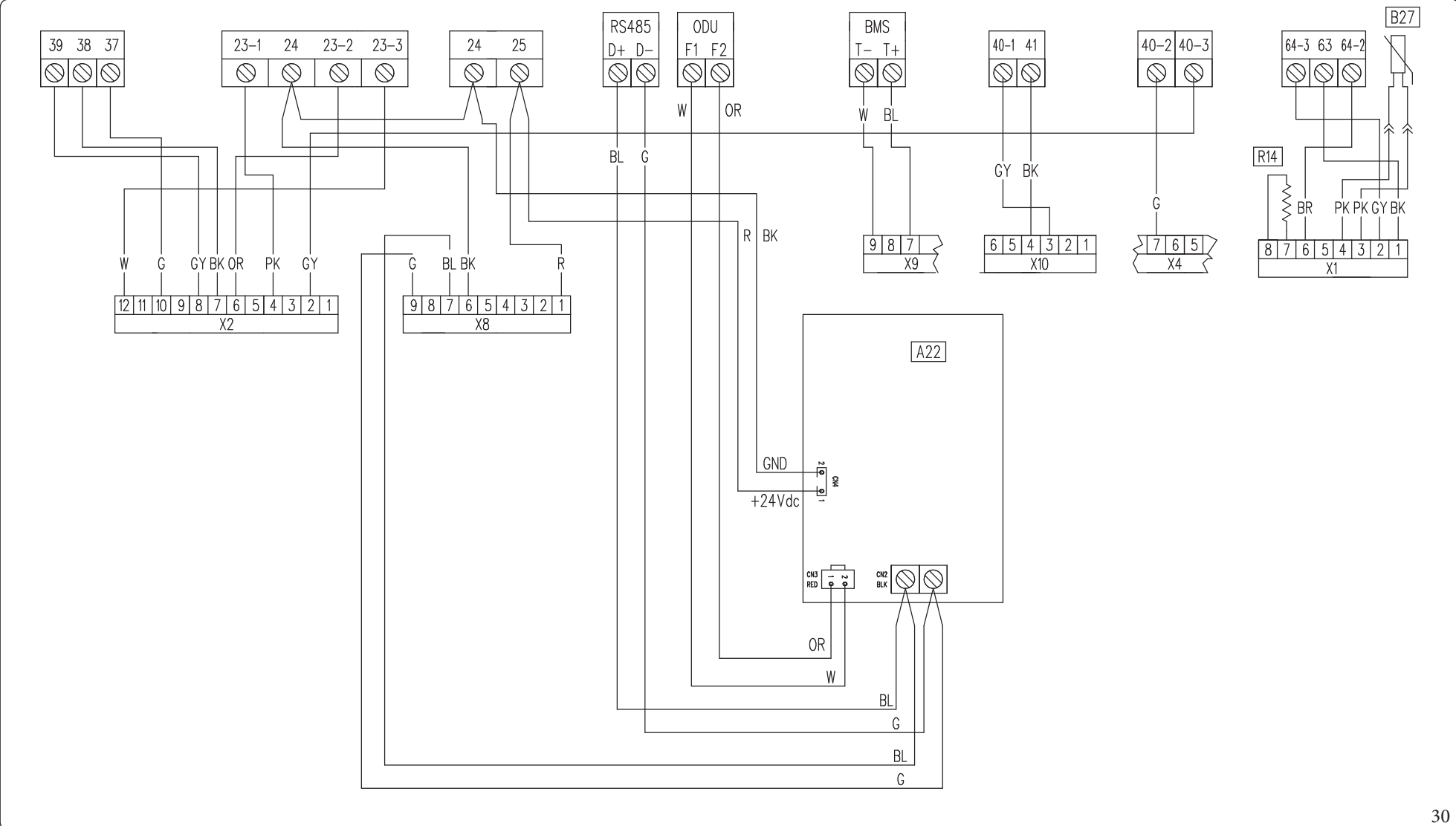

Key (Fig. 30):
 A22 - Condensing unit interface board
 B27 - Liquid phase probe
 R14 - Configuration resistance

Colour code key (Fig. 30):
 BK - Black
 BL - Blue
 BR - Brown
 G - Verde
 GY - Grey
 G/Y - Yellow/Green

OR - Orange
 P - Viola
 PK - Pink
 R - Red
 W - White
 Y - Yellow
 W/BK - White/Black

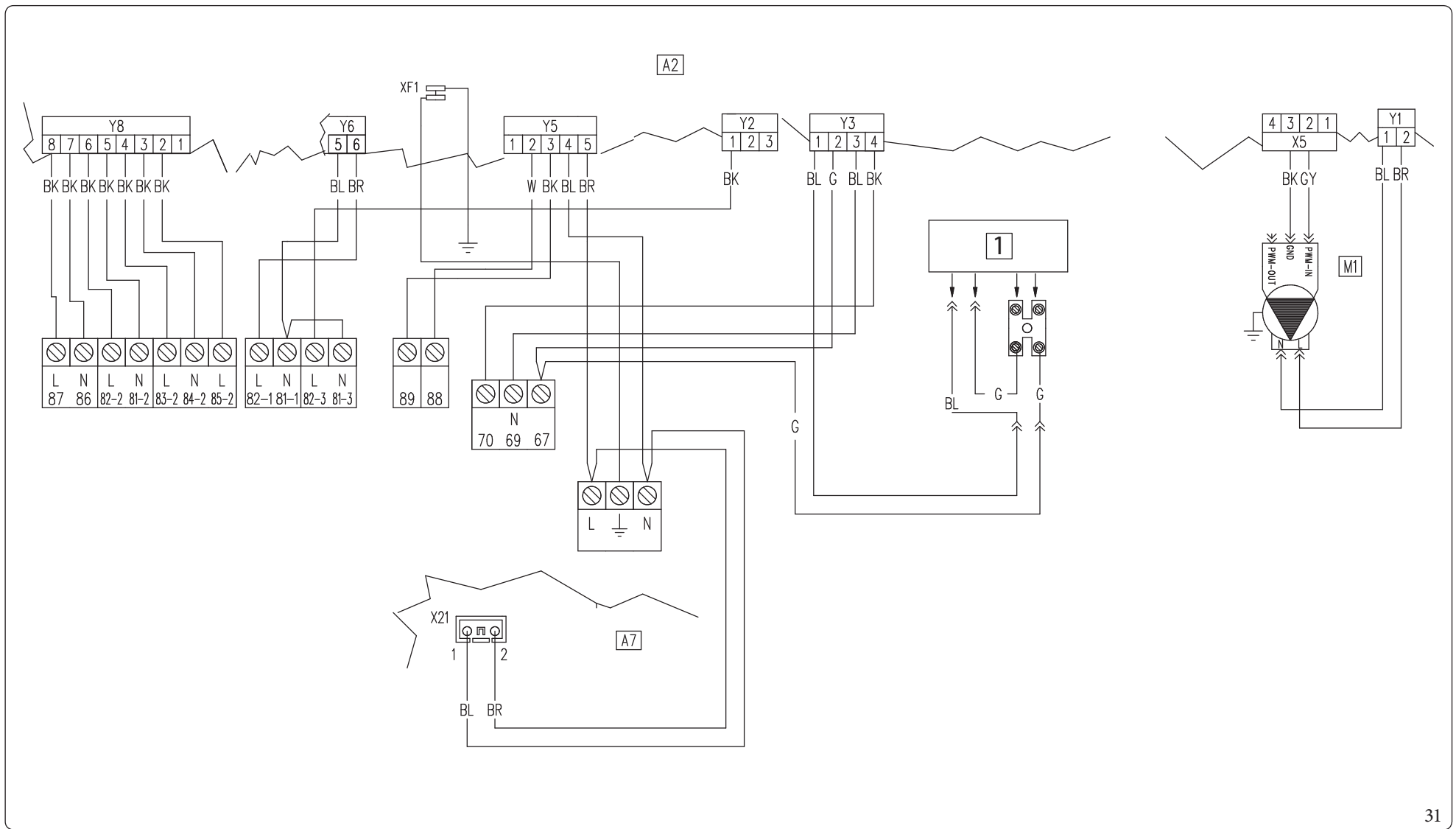

Key (Fig. 31):

- 1 - Integrated resistance kit for 3kw system
- A2 - P.C.B.
- A7 - Relay board
- M1 - Heat pump circulator pump

Colour code key (Fig. 31):

- BK - Black
- BL - Blue
- BR - Brown
- G - Verde
- GY - Grey
- G/Y - Yellow/Green

- OR - Orange
- P - Viola
- PK - Pink
- R - Red
- W - White
- Y - Yellow
- W/BK - White/Black

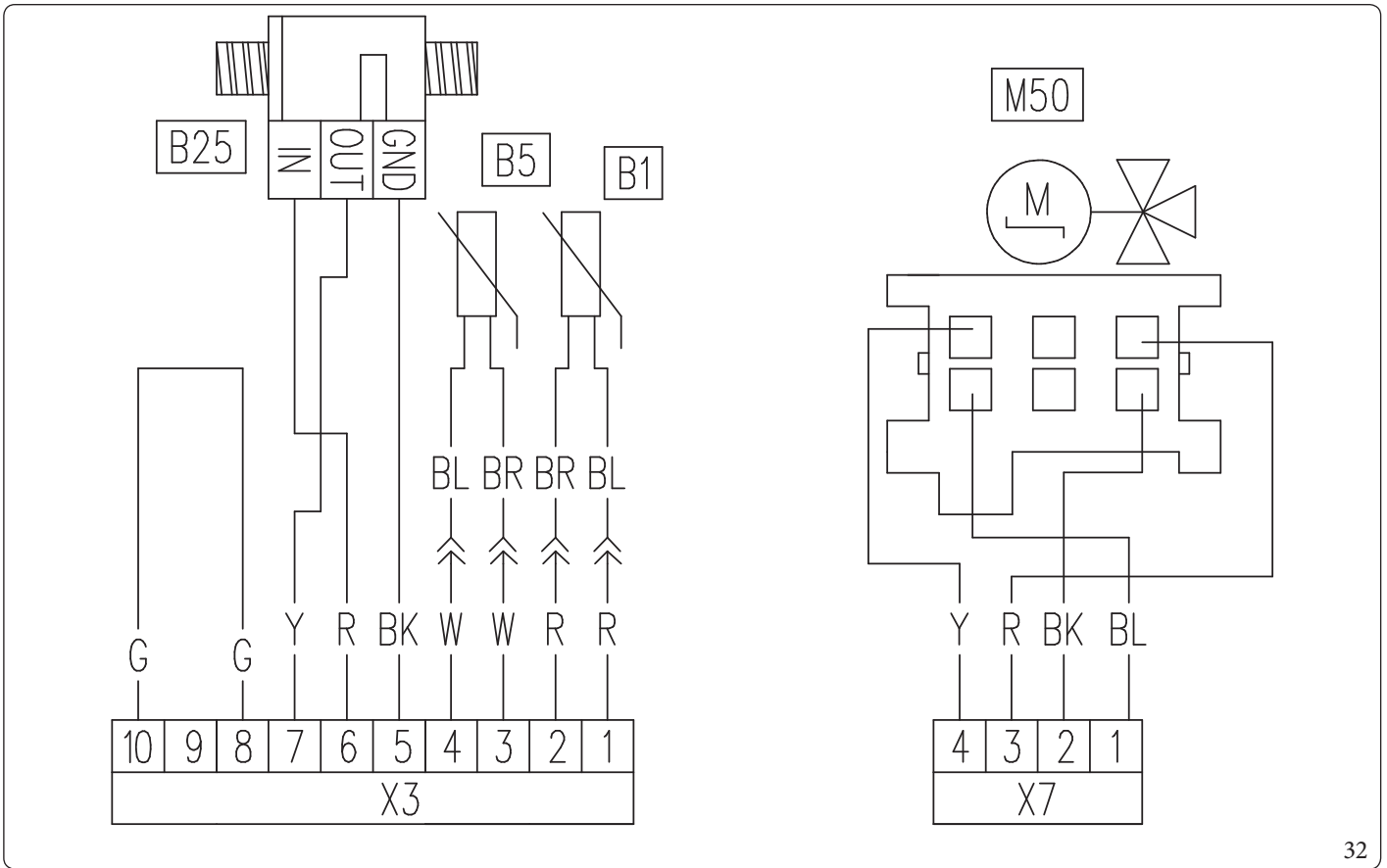

Key (Fig. 32):

- B1 - Heat pump flow probe
- B5 - Heat pump return probe
- B25 - System flow meter
- M50 - DHW priority 3-way valve

Colour code key (Fig. 32):

- BK - Black
- BL - Blue
- BR - Brown
- G - Verde
- GY - Grey
- G/Y - Yellow/Green
- OR - Orange
- P - Viola
- PK - Pink
- R - Red
- W - White
- Y - Yellow
- W/BK - White/Black

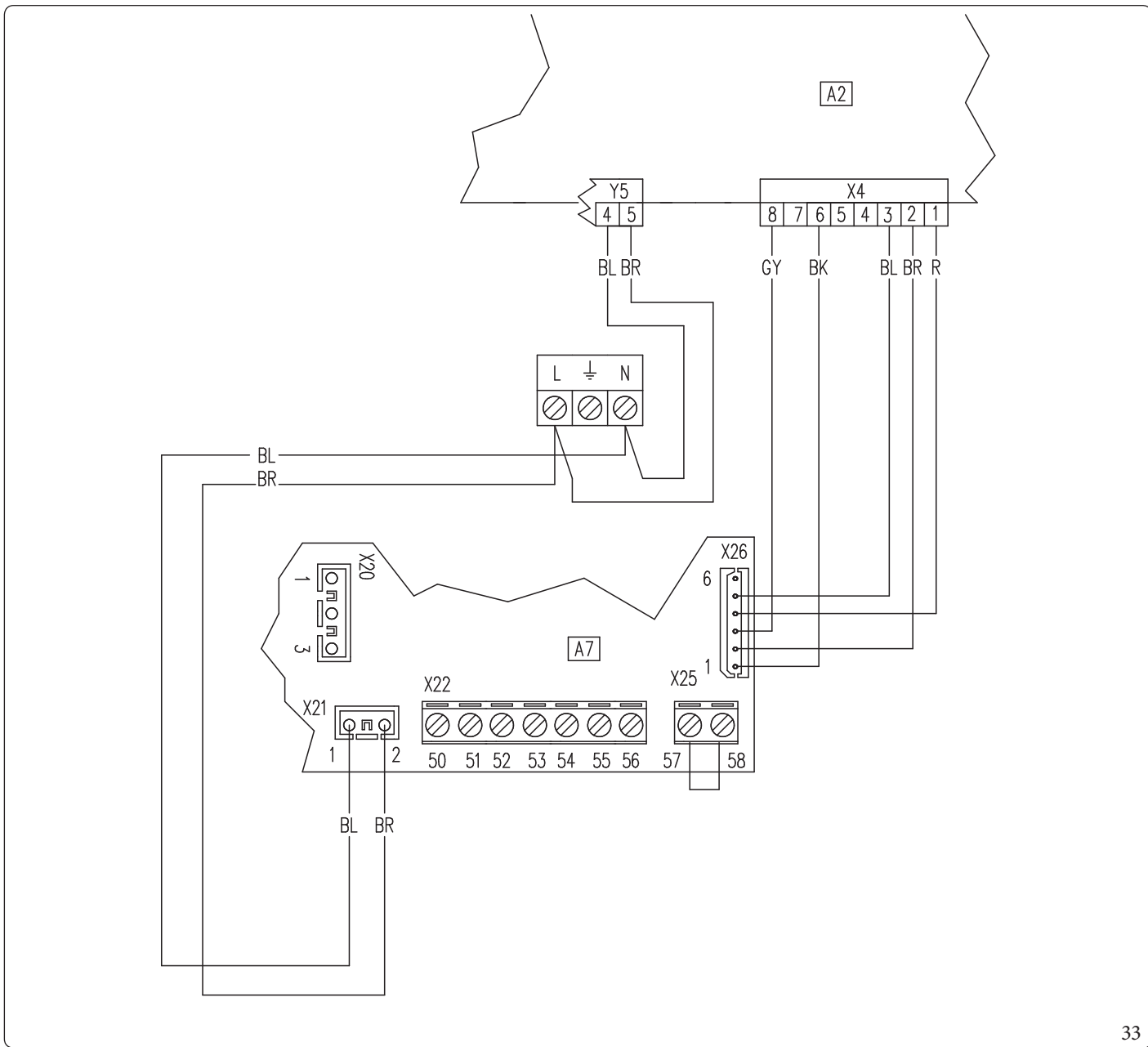

33

Key (Fig. 33):

- A2 - P.C.B.
- A7 - Three-relay board (optional)

Colour code key (Fig. 33):

- BK - Black
- BL - Blue
- BR - Brown
- G - Verde
- GY - Grey
- G/Y - Yellow/Green
- OR - Orange
- P - Viola
- PK - Pink
- R - Red
- W - White
- Y - Yellow
- W/BK - White/Black

INSTALLER

USER

MAINTENANCE/TECHNICIAN

TECHNICAL DATA

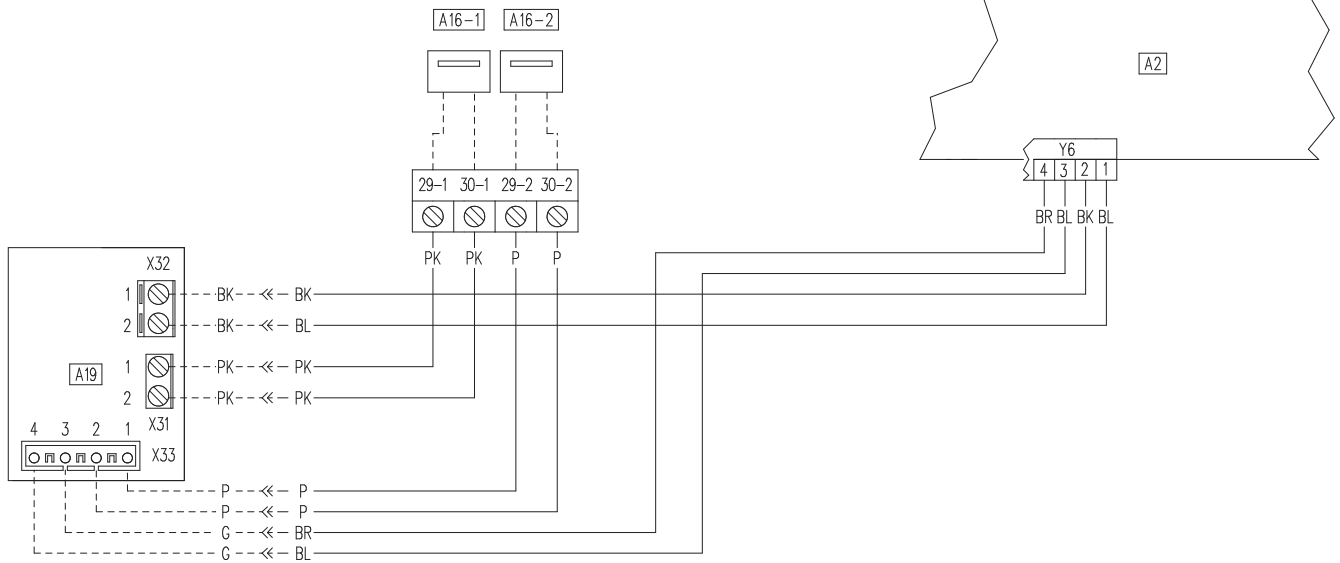

Key (Fig. 34):

- A2 - P.C.B.
- A16-1 - Zone 1 dehumidifier (optional)
- A16-2 - Zone 2 dehumidifier (optional)
- A19 - Two-relay board (optional)

Colour code key (Fig. 34):

- BK - Black
- BL - Blue
- BR - Brown
- G - Green
- GY - Grey
- G/Y - Yellow/Green
- OR - Orange
- P - Purple
- PK - Pink
- R - Red
- W - White
- Y - Yellow
- W/BK - White/Black

P.C.B.

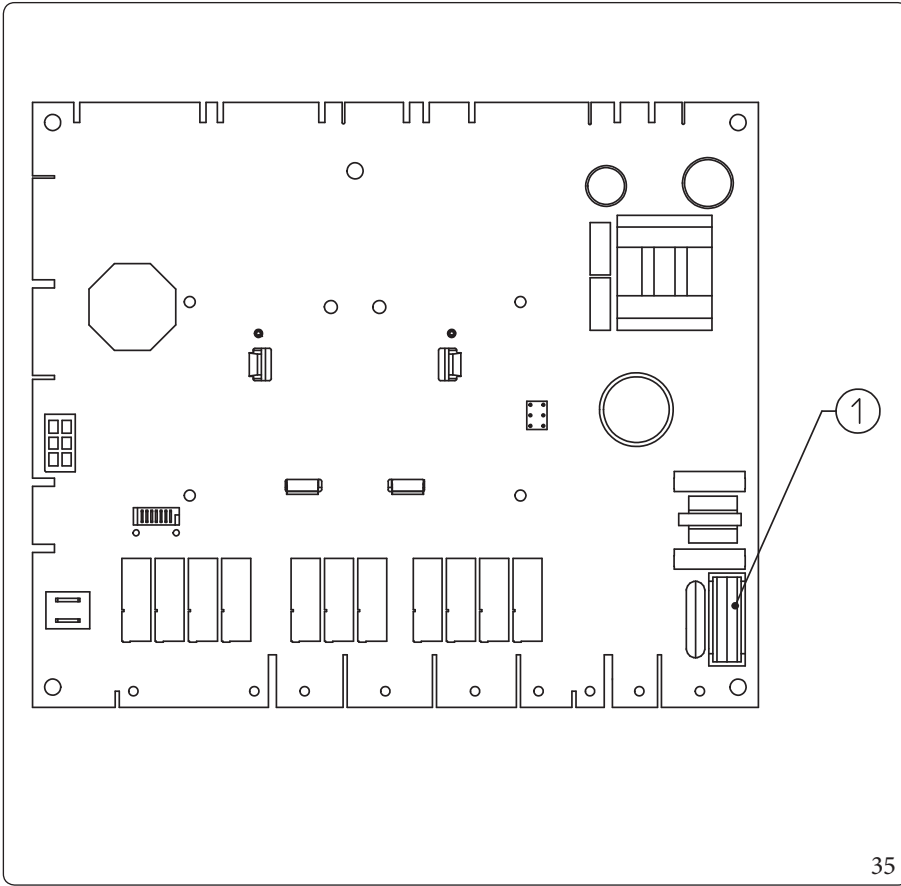

Key (Fig. 35):

1 - F3.15AH250V fuse

35

Interfaceboard - setting switch

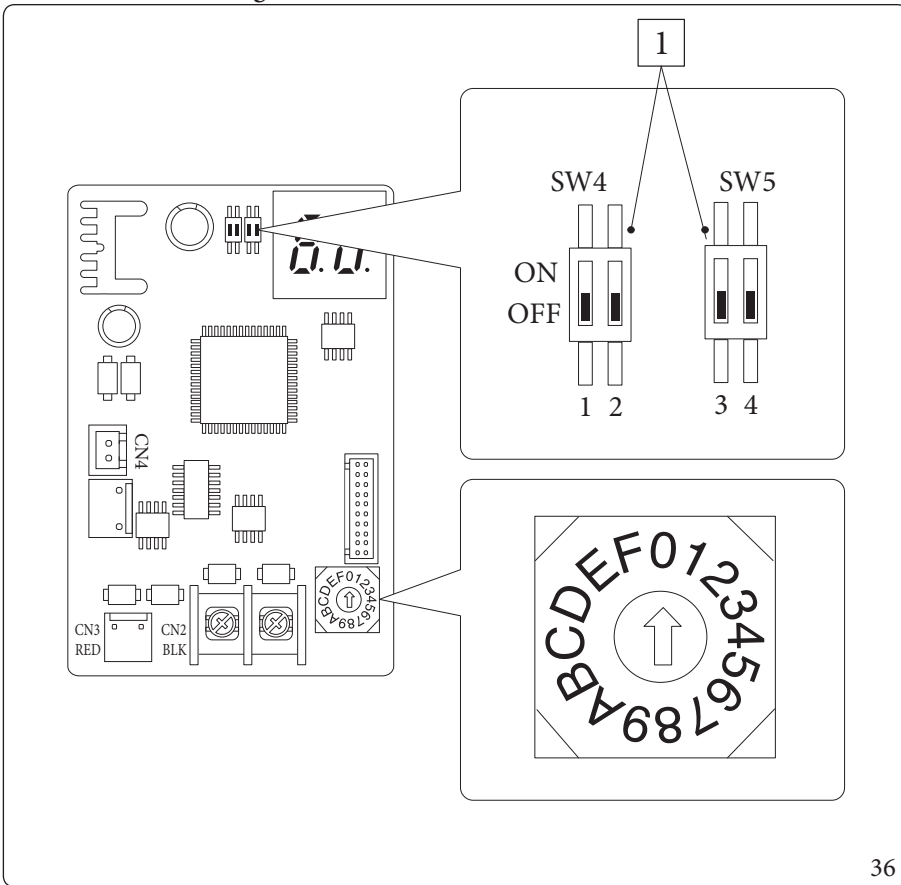

Key (Fig. 36):

1 - Factory setting: do not change

36

INSTALLER

USER

MAINTENANCE/TECHNICIAN

TECHNICAL DATA

Interfaceboard - indicator LED

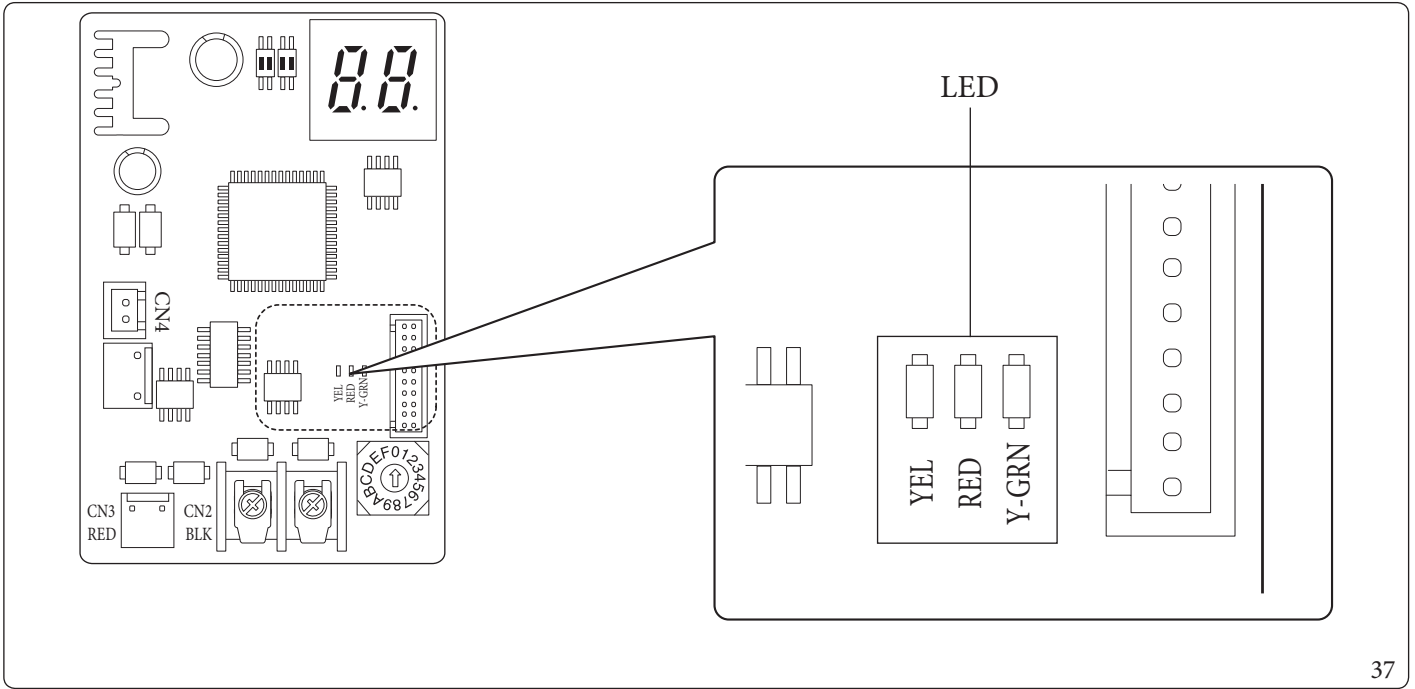

37

Key (Fig. 37):

- Red LED flashing = Communication between interface board and P.C.B. valid
- Green LED flashing = Communication between interface board and outdoor unit valid
- Yellow LED = Not Used

Interface board - 7-segment display

During normal operation, the display shows “A0” for 1 second, followed by “30” for 1 second:

	SEGMENTS
VALID COMMUNICATION	

In case of an error of the outdoor unit, a sequence of two digits at a time is displayed: “E” plus outdoor unit error code:

ERROR CODES	SEGMENTS
E101	

3.7 SYSTEM FILTER

The indoor unit has a filter on the system return fitting to keep the system in good operating conditions.

Periodically and when necessary, the filter can be cleaned as described below (Fig. 38).

Close the tap (3) with a size 12 spanner and tap (5) by hand, drain out the water contained in the indoor unit using the draining valve (4). Open the cap (1) and clean the filter (2).

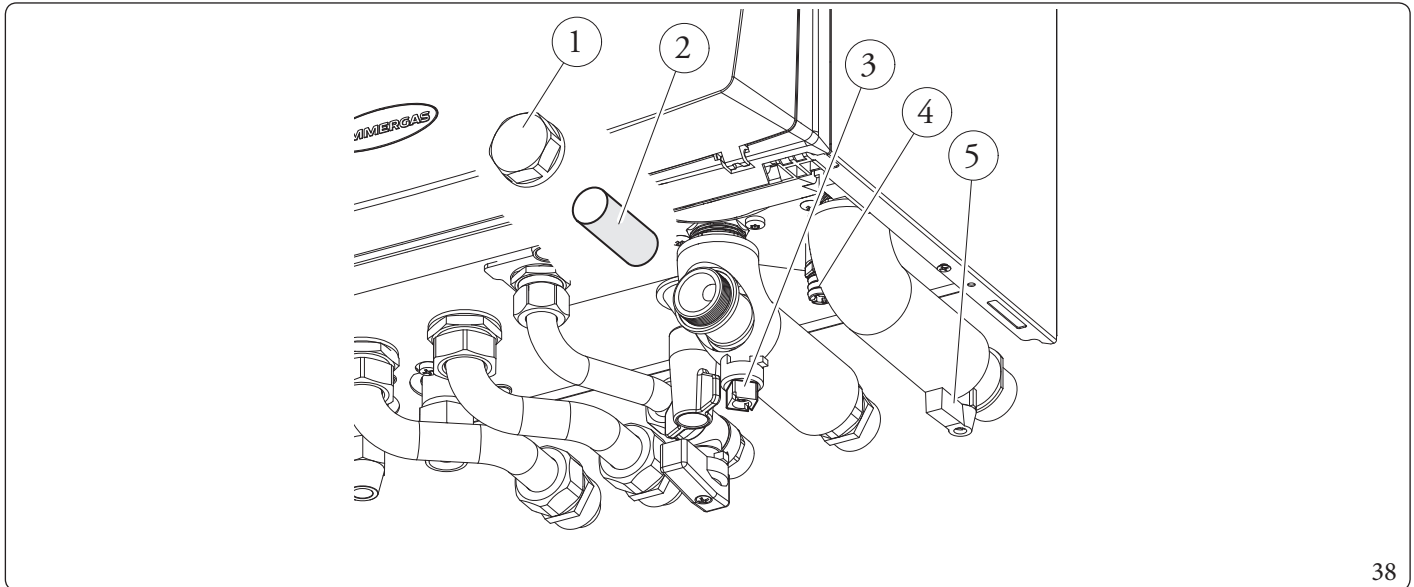

3.8 TROUBLESHOOTING



Maintenance operations must be carried out by an authorised company (e.g. Authorised After-Sales Technical Assistance Centre).

Noise due to air in the system.

Check opening of the hood of the special air vent valve (Fig. 22).

Make sure the system pressure and expansion tank factory-set pressure values are within the set limits.

The factory-set pressure values of the expansion vessel must be 1.0 bar, the value of system pressure must be between 1 and 1.2 bar.

Red pump LED.

There can be three possible causes for this anomaly:

- **Low power supply voltage.** About 1-2 seconds after the voltage drops below 145Vac, the LED switches from green to red and the pump stops. Wait for the supply voltage to raise above 155Vac approximately: the pump starts back up and the LED goes back to green with a delay of about one second (Note: naturally the flow rate decreases with the decrease of the supply voltage).
- **Rotor locked.** Powering the pump with the rotor seized, after about 4 seconds the LED switches from green to red. Carefully act on the screw in the middle of the head to manually release the crankshaft; circulation starts up immediately after the rotor is released and the LED switches from red to green after about 10 seconds.
- **Electrical fault.** Pump, wiring or P.C.B. fault. Check the indicated components.

3.9 P.C.B. PROGRAMMING

The water heater is set up for possible programming of several operation parameters. By modifying these parameters as described below, the system can be adapted according to specific needs.

To access the programming phase, press the “MENU” button (2) until the “Password” menu appears. Enter the password, modify the numerical values using the “central heating regulation” buttons (5) and confirm with the “OK” button (1).

Once you have accessed programming, you can scroll through the parameters in the “System” menu.

Using the “central heating regulation” button, select the parameter and edit the value.

To save the parameter change, press the “OK” button.

Wait for 1 minute or press the “ESC” button (3) to exit programming mode.

Id Parameter	Parameter	Description	Range	Default	Value customized
A03	Minimum speed	Defines the minimum operating speed of the system circulator pump	0 ÷ 100%	55	
A04	Maximum fixed speed	Defines the maximum operating speed of the system circulator pump	45 ÷ 100%	100	
A05	Circulator mode	0 = Fixed (See Parag. “Circulation pump”) 5 - 25 K = ΔT constant (See Parag. “Circulation pump”)	0 - 25°C	0	
A11	Outdoor unit model	Establishes the outdoor unit model paired with the indoor unit. If set to OFF, only the integrated generators are activated.	OFF - 4 - 6 - 9	9	
A12	System vent	Enables the automatic vent function. This function activates as soon as the unit is powered.	OFF - ON	ON	
A13	Number of zones	Defines the number of zones in the heating system	1 - 3	1	
A14	Zone 2 max temperature	Defines the maximum temperature acceptable by zone 2	20 ÷ 80°C	45	
A15	Zone 3 max temperature	Defines the maximum temperature acceptable by zone 3	20 ÷ 80°C	45	
A16	Zone 1 humidity sensor	Defines the type of control on zone 1 humidity	SE = Humidity temp. Sensor ST = Humidistat RP - Remote panel	ST	

Id Parameter	Parameter	Description	Range	Default	Value customized
A 17	Zone 2 humidity sensor	Defines the type of control on zone 2 humidity	ST = Humidistat RP - Remote panel	ST	
A 21	BMS communication address	Defines the communication protocol between the indoor unit and the outdoor unit	1 ÷ 247	11	
A 22	BMS communication setting	OFF = BMS communication protocol on 485; use if connected to optional Immergas devices. 485 = Do not use	OFF - 485	OFF	
A 23	Zone 3 humidity sensor	Defines the type of control on zone 3 humidity	SE = Humidity temp. Sensor ST = Humidistat RP - Remote panel	ST	
A 24	Zone 1 max temperature	Defines the maximum temperature acceptable by zone 1	20 ÷ 80 °C	55	
A 25	Dew point enabling	In the presence of a remote device, enables calculation of the dew point	OFF - ON	ON	
A 27	Zone 1 flow probe	It allows enabling the zone 1 flow probe	OAT = Use of external probe on the indoor unit	OAT	
A 31	Zone 1 room thermostat	Defines the temperature control in zone 1	RT = Room thermostat RP - Remote panel	RT	

INSTALLER

USER

MAINTENANCE/TECHNICIAN

TECHNICAL DATA

Id Parameter	Parameter	Description	Range	Default	Value customized
A 32	Zone 2 room thermostat	Defines the temperature control in zone 2	RP - Remote panel	RT	
			RPT = Remote panel with Thermostat		
A 33	Zone 3 room thermostat	Defines the temperature control in zone 3	RT = Room thermostat	RT	
			RP - Remote panel		
			RPT = Remote panel with Thermostat		
A 35	Room probe modulation	In the presence of Zone Remote panel, configured in RP, enables modulation with room probe	OFF - ON	ON	
A 39	Heating/ Cooling contact	Enables the Heating/Cooling function by means of a dry contact	OFF - ON	OFF	
A 41	Zone 1 heating/ cooling enable	Allows to determine heating, cooling mode or both of zone 1	HT/CL/H -C	H - C	
A 42	Zone 2 heating/ cooling enable	Allows to determine heating, cooling mode or both of zone 2	HT/CL/H -C	H - C	
A 43	Zone 3 heating/ cooling enable	Allows to determine heating, cooling mode or both of zone 3	HT/CL/H -C	H - C	
A 51	Dehumidifier flow setpoint zone 1	Setpoint used by the machine for dehumidification demand on zone 1 without cooling demands present	15 ÷ 25 °C	20	
A 52	Dehumidifier flow setpoint zone 2	Setpoint used by the machine for dehumidification demand on zone 2 without cooling demands present	15 ÷ 25 °C	20	
A 53	Dehumidifier flow setpoint zone 3	Setpoint used by the machine for dehumidification demand on zone 3 without cooling demands present	15 ÷ 25 °C	20	

Id Parameter	Parameter	Description	Range	Default	Value customized
P03	Relay 1 (optional)	The indoor unit is set-up for functioning with the relay P.C.B. (optional), which can be configured 0 = Off 1 = DHW recirculation 2 = General alarm 3 = Central heating / cooling mode active 4 = Puffer mode active 5 = Dehumidifier zone 3	0 ÷ 4	0	
P04	Relay 2 (optional)	The indoor unit is set-up for functioning with the relay P.C.B. (optional), which can be configured 0 = Off 1 = DHW recirculation 2 = General alarm 3 = Central heating / cooling mode active 4 = Puffer mode active 5 = Zone 3 mixing valve closing	0 ÷ 4	0	
P05	Relay 3 (optional)	The indoor unit is set-up for functioning with the relay P.C.B. (optional), which can be configured 0 = Off 1 = DHW recirculation 2 = General alarm 3 = Central heating / cooling mode active 4 = Puffer mode active 5 = Zone 3 mixing valve opening	0 ÷ 4	0	
P07	External probe correction	If the reading of the external probe is not accurate, it is possible to correct it in order to compensate any environmental factors.	-9 ÷ 9 K	0	
P11	Gen. DHW setpoint offset	The DHW flow setpoint of the generator is calculated by adding P11 to the DHW setpoint	2 ÷ 30 °C	10	
P12	DHW electric resistance tripping offset	Call an Authorised After-Sales Technical Assistance Centre	5 ÷ 50 °C	10	
P13	T max anti-Le- gionella	Maximum time to perform anti-Legionella function	1 - 24 hours	3	
P14	T max DHW	Maximum time to perform DHW function	1 - 24 hours	5	

INSTALLER

USER

MAINTENANCE TECHNICIAN

TECHNICAL DATA

Id Parameter	Parameter	Description	Range	Default	Value customized
P 15	Anti-Legionella function enable	Enable running of anti-Legionella function	OFF - ON	OFF	
P 16	Anti-Legionella start time	Allows to set when anti-Legionella function starts	0 - 23	2	
P 17	Anti-Legionella activation day	Allows to set the weekday on which to activate the anti-Legionella function. You may even activate the function continuously every day.	Mo-Tu-We-Th- Fr-Sa-Su	Mo	
P 21	Activation time	Temperature setpoint - Activation time correction	0 - 120 minutes	20	
P 22	Increase time	Temperature setpoint - Increment time correction	0 - 20 minutes	5	
P 23	Heat setpoint correction	Allows to correct the heating mode demand setpoint in presence of dispersions or system decoupling circuits	0 ÷ 10°C	0	
P 24	Cool setpoint correction	Allows to correct the cooling mode demand setpoint in presence of dispersions or system decoupling circuits	0 ÷ 10°C	0	

Id Parameter	Parameter	Description	Range	Default	Value customized
T02	D.H.W. thermostat	Establishes the unit ignition and switch-off mode in DHW mode. It is enabled when the water in the storage tank goes below the DHW set value and is disabled when the temperature exceeds the DHW set value.	0 ÷ 20 °C	4	
T05	Ignitions timer	The indoor unit has an electronic timer that controls restarting the compressor of the outdoor unit.	0 - 10 minutes	3	
T07	Delay request from TA	The system is set to switch on immediately after a request for room air conditioning. For special systems (e.g. zone systems with motorised valves, etc.), it may be necessary to delay ignition.	0 - 240 seconds (10 sec step)	0	
T08	Display lighting	Establishes the display lighting mode. AU: the display lights up during use and lowers after 15 seconds of inactivity. In the event of an anomaly, the display flashes. OFF: the display lighting is always off. ON: the display lighting is always on.	AU - OFF - ON	AU	
T09	Display	Establishes what the indicator displays 14 (Fig. 14). “Summer” mode: ON: active circulator, this displays the flow temperature, with circulator off the indicator is off OFF: the indicator is always off “Winter” and “cooling” mode: ON: circulator pump active displays the flow temperature, pump off displays the value set on the central heating selector. OFF: always displays the value set on the central heating selector	ON - OFF	ON	
T21	Screed heating - days at minimum temperature	Defines the time spent at minimum operating temperature during the active function	0 ÷ 7 days	3	
T22	Screed heating - ascent gradient	Defines the ascent gradient of the temperature	0 ÷ 30 °C / day	30	
T23	Screed heating - days at maximum temperature	Defines the time spent at maximum operating temperature during the active function	0 ÷ 14 days	4	
T24	Screed heating - descent gradient	Defines the descent gradient of the temperature	0 ÷ 30 °C / day	30	

INSTALLER

USER

MAINTENANCE TECHNICIAN

TECHNICAL DATA

Heat regulation menu.

Id Parameter	Parameter	Description	Range	Default	Value customized
R01	External probe	Defines if and which external probe is used to manage the system. OFF = no external probe used OU = external probe on outdoor unit IU = optional external probe connected to the indoor unit	OFF - OU - IU	OU	
R02	Outdoor temperature for max CH flow zone 1	Establishes the outdoor temperature at which to have the maximum flow temperature of zone 1.	-15 ÷ 25°C	-5	
R03	Outdoor temperature for min CH flow zone 1	Establishes the outdoor temperature at which to have the minimum flow temperature of zone 1.	-15 ÷ 25°C	25	
R04	Zone 1 maximum central heating	Defines the maximum flow temperature in zone 1 room central heating mode	20 ÷ 65	45	
R05	Zone 1 minimum central heating	Defines the minimum flow temperature in zone 1 room central heating mode	20 ÷ 65	25	
R06	Outdoor temperature for max zone 2 CH flow mixed zone	Establishes the outdoor temperature at which to have the maximum flow temperature of zone 2	-15 ÷ 25°C	-5	
R07	Outdoor temperature for min zone 2 CH flow mixed zone	Establishes the outdoor temperature at which to have the minimum flow temperature of zone 2	-15 ÷ 25°C	25	
R08	Zone 2 mixed zone maximum central heating	Defines the maximum flow temperature in zone 2 room central heating mode	20 ÷ 65	40	
R09	Zone 2 mixed zone minimum central heating	Defines the minimum flow temperature in zone 2 room central heating mode	20 ÷ 65	25	
R10	Zone 1 outdoor temperature for minimum cooling flow	Establishes the maximum outdoor temperature at which to have the minimum flow temperature in zone 1 cooling mode	20 ÷ 40	35	

Id Parameter	Parameter	Description	Range	Default	Value customized
R11	Outdoor temperature for Zone 1 maximum cooling flow	Establishes the minimum outdoor temperature at which to have the maximum flow temperature in zone 1 cooling mode	20 ÷ 40	25	
R12	Zone 1 minimum cooling	Defines the minimum flow temperature in zone 1 room cooling mode	5 ÷ 20	7	
R13	Zone 1 maximum cooling	Defines the maximum flow temperature in zone 1 room cooling mode	5 ÷ 25	12	
R14	Outdoor temperature for zone 2 min cooling flow mixed zone	Establishes the outdoor temperature at which to have the minimum flow temperature of zone 2	20 ÷ 40	35	
R15	Outdoor temperature for zone 2 max cooling flow mixed zone	Establishes the outdoor temperature at which to have the maximum flow temperature of zone 2	20 ÷ 40	25	
R16	Zone 2 mixed zone minimum cooling	Defines the minimum flow temperature in zone 2 room cooling mode	5 ÷ 20	18	
R17	Zone 2 mixed zone maximum cooling	Defines the maximum flow temperature in zone 2 room cooling mode	5 ÷ 25	20	
R21	Outdoor temperature for max CH flow zone 3	Establishes the outdoor temperature at which to have the maximum flow temperature of zone 3	-15 ÷ 25°C	-5	
R22	Outdoor temperature for min CH flow zone 3	Establishes the outdoor temperature at which to have the maximum flow temperature of zone 3	-15 ÷ 25°C	25	
R23	Zone 3 maximum central heating	Establishes the outdoor temperature at which to have the maximum flow temperature of zone 3	20 ÷ 65	40	
R24	Zone 3 minimum central heating	Establishes the outdoor temperature at which to have the maximum flow temperature of zone 3	20 ÷ 65	25	

INSTALLER

USER

MAINTENANCE TECHNICIAN

TECHNICAL DATA

Id Parameter	Parameter	Description	Range	Default	Value customized
R25	Outdoor temperature for Zone 3 low temperature zone min cooling flow	Establishes the outdoor temperature at which to have the maximum flow temperature of zone 3	20 ÷ 40	35	
R26	Outdoor temperature for Zone 3 low temperature zone max cooling flow	Establishes the outdoor temperature at which to have the maximum flow temperature of zone 3	20 ÷ 40	25	
R27	Zone 3 low temperature zone minimum cooling	Establishes the outdoor temperature at which to have the maximum flow temperature of zone 3	5 ÷ 20	18	
R28	Zone 3 low temperature zone maximum cooling	Establishes the outdoor temperature at which to have the maximum flow temperature of zone 3	5 ÷ 25	20	

Integration menu.

Id Parameter	Parameter	Description	Range	Default	Value customized
I01	DHW integration enabling	Allows you to enable an alternative power source (AL) to integrate domestic hot water heating	OFF - AL	OFF	
I02	System integration enabling	Using this function, you can enable an alternative (AL) or simultaneous (CO) power source to integrate heating system central heating.	OFF - AL - CO	OFF	
I03	DHW max wait time	Establishes the maximum amount of time before activating DHW integration.	1 - 255 minutes	240	
I04	Central heating max wait time	Establishes the maximum amount of time before activating central heating integration.	1 - 255 minutes	120	
I08	Simultaneous D.H.W.	Enables the simultaneous operation in DHW mode and room air conditioning mode	OFF - ON	ON	
I09	DHW activation temperature	Establishes the outdoor temperature under which DHW integration is enabled	-25 ÷ 35°C	-15	
I10	System activation temperature	Establishes the outdoor temperature under which system integration is enabled	-25 ÷ 35°C	-15	
I11	Outdoor unit operating hours	Displays the hours of operation performed by the outdoor unit	-	-	
I12	Heating integration resistance hours of operation	Displays the hours of operation of the central heating integration resistance (optional)	-	-	
I13	DHW integration resistance hours of operation	Displays the hours of operation of the DHW integration resistance (optional)	-	-	
I15	Preheat function enabling temperature	If system integration is enabled, this is the temperature below which the preheat function is activated	14 ÷ 25°C	20	

INSTALLER

USER

MAINTENANCE/TECHNICIAN

TECHNICAL DATA

Maintenance menu.

Accessing this menu, the unit goes into stand-by. By selecting every single parameter, you can activate a specific function for each load.

Id Parameter	Parameter	Description	Range	Default	Value customized
M02	System circulator pump speed	Establishes the system circulator pump speed	0 - 100%	0	
M03	DHW 3-way	Moves the 3-way motor from system to DHW	DHW-CH-MD	DHW	
M04	Cooling 3-way	Moves the cooling circuit 3-way motor	OFF - ON	OFF	
M08	Zone 1 outdoor circulator pump	Enables the zone 1 outdoor circulator pump	OFF - ON	OFF	
M09	Zone 2 outdoor circulator pump	Enables the zone 2 outdoor circulator pump	OFF - ON	OFF	
M10	Mixer zone 2	Establishes zone 2 mixing valve positioning	OFF - OPEN - CLOSE	OFF	
M11	DHW electrical resistance	Enables the DHW integrated electrical resistance	OFF - ON	OFF	
M12	Central heating electrical resistance	Enables the room central heating integrated electrical resistance	OFF - ON	OFF	
M13	Dehumidifier zone 1	Enables the dehumidifier in zone 1	OFF - ON	OFF	
M14	Dehumidifier zone 2	Enables the dehumidifier in zone 2	OFF - ON	OFF	
M15	Relay 1	Enables relay 1 on the 3-relay board	OFF - ON	OFF	
M16	Relay 2	Enables relay 2 on the 3-relay board	OFF - ON	OFF	
M17	Relay 3	Enables relay 3 on the 3-relay board	OFF - ON	OFF	
M18	Zone 3 outdoor circulator pump	Enables the zone 3 outdoor circulator pump.	OFF - ON	OFF	
M19	Dehumidifier zone 3	Enables the zone 3 outdoor circulator pump.	OFF - ON	OFF	
M20	Zone 3 mixing valve	Enables the zone 3 outdoor circulator pump.	OFF - OPEN - CLOSE	OFF	

3.10 FIRST IGNITION PARAMETER SETTING

During the first activation of the appliance, it is necessary to customise the following parameters, which concern the generator operation, the type of outdoor unit and the type of system connected to the appliance.

Heat pump power

Set parameter A11 according to the type of outdoor unit connected.

Circulator speed

Set parameter A05 to define the operating mode of the pump.

Set parameters A03 and A04 to define the maximum and minimum speed of the pump.

It is necessary to adjust the pump speed according to the appliance power, to improve the operating efficiency of the machine.

It is suggested to set the values indicated in Parag. 1.20 - 1.21.

Number of zones

Set parameter A13 according to the number of zones in the system that are directly controlled by the machine.

3.11 PUMP ANTI-BLOCK FUNCTION

The indoor unit has a function that starts the pump at least once every 24 hours for the duration of 30 seconds in order to reduce the risk of the pump becoming blocked due to prolonged inactivity.

3.12 THREE-WAY ANTI-BLOCK SYSTEM

The indoor unit has a function that activates the motorised three-way unit 24 hours after the last time it operated by running a complete cycle in order to reduce the risk of the three-way blocking due to prolonged inactivity.

3.13 RADIATORS ANTIFREEZE FUNCTION

If the system return water is below 4°C, the indoor unit starts up until reaching 42°C.

3.14 PHOTOVOLTAIC FUNCTION

If the photovoltaic contact (contact "S 39" Fig. 8) is closed, any DHW (Domestic hot water) stored is heated to a temperature of 55°C by means of heat pump operation in the absence of system requests.

The storage tank is only heated with DHW control.

3.15 OUTDOOR UNIT DISABLE FUNCTION

With input active (contact "S 41" Fig. 8), external unit operation is inhibited.

The demands can be met by any electrical resistances appropriately connected and configured.

3.16 DIVERTER VALVE MANAGEMENT (SUMMER / WINTER).

The unit electronics has a 230V outlet to manage the summer / winter diverter valves.

The voltage output is active when the appliance is in Air-conditioning mode.

3.17 ANTI-LEGIONELLA FUNCTION (IF PAIRED WITH A STORAGE TANK UNIT)

The indoor unit is equipped with a function to perform a thermal shock on the storage tank.

This function brings the generator temperature to the maximum allowed with DHW integrative resistance enabled.

The function is enabled with parameter "P 15".

The function activates at the time set on parameter P 16, on the weekday set on Parameter "P 17"; the function can be activated every day by setting "P 17"="ALL".

The maximum allowed duration of the function is "P 13" hours; if the function is not completed within the maximum allowed time, an alarm will be triggered.



The function can only be activated in presence of integrative DHW resistance and eventually a thermostatic valve must be installed at the DHW outlet to prevent burns.

3.18 AUTOMATIC VENTING FUNCTION

In the case of new central heating systems and in particular mode for floor systems, it is very important that deaeration is performed correctly.

The function consists of the cyclic activation of the pump and the 3-way valve.

The function is activated in two different ways:

- Each time the heat generator is re-powered;
- Using parameter "U 50".

In the first case, the function has a duration of 8 minutes and it can be interrupted by pressing the "Reset" button (3). In the second case, it has a duration of 18 hours and it can be interrupted simply by switching the heat generator on.

Activation of the function is signalled by the countdown shown on the indicator (14).

3.19 PREHEATING FUNCTION

In case of DHW (Domestic hot water) or central heating request, if the water temperature is lower than the value set on parameters I15, the operation of the heat generator is forced until +5°C are reached with respect to the value set on parameter I15.

The function remains active for a maximum of 2 hours.

If needed, the function can be bypassed by disabling the system's electric resistance.

3.20 SCREED HEATER FUNCTION

The indoor unit is equipped with a function to perform the thermal shock on new radiant panel systems, as required by the applicable standard.



Contact the manufacturer of the radiant panels for the thermal shock characteristics and its correct execution.



To be able to activate the function there must be no remote control connected, while in case of system divided into zones it must be properly connected, both hydraulically and electrically.



The active zone pumps are those with ongoing requests, made via the room thermostat input.

The function is activated from indoor unit in stand-by by pressing and holding the buttons “Reset” and “Mode” for more than 5 seconds (Fig. 39).

The standard function lasts in total 7 days - 3 days at the lowest temperature set and 4 days at the highest temperature set (Fig. 40).

Duration can be changed by changing the value of parameters “T022”, “T024”.

After activating the function, the lower set (range 20 ÷ 45 °C default = 25 °C) and the higher set (range 25 ÷ 55 °C default = 45 °C) appear in sequence.

The temperature is selected by means of the buttons “+” and “-” of the system side ( ) and confirmed by pressing the button “Mode”.

The display now shows the countdown of days alternated with the current flow temperature, as well as the normal operating symbols of the indoor unit.

In case of failure, the function is suspended and will resume when normal operating conditions are reset from the point where it was interrupted.

In case of power failure, the function is suspended.

When the time expires, the indoor unit automatically goes back to “Stand-by” mode, the function can also be stopped by pressing the button “Mode”.

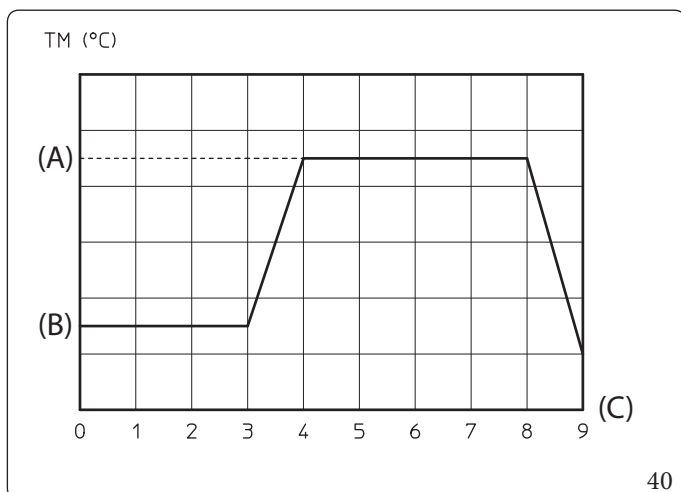
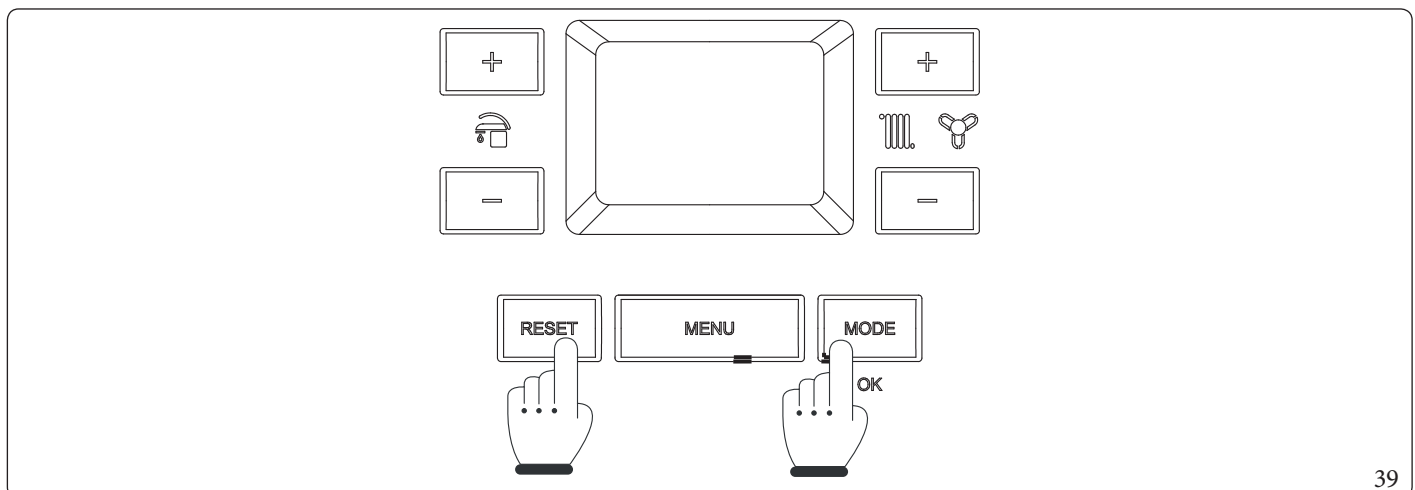

Key (Fig. 40):

- (A) - Top set
- (B) - Lower set
- (C) - Days

40

3.21 DEHUMIDIFICATION FUNCTION

Dehumidification can be performed according to three different types of devices:

- 1) Humidistat;
- 2) Humidity sensor;
- 3) Remote zone panel.

In the first case, the cooling mode temperature corresponds to:

- In the event of dehumidification request: maximum setpoint set for the request zone;
- In the event of dehumidification and cooling request: setpoint set for the request zone.

In the second and third cases, the cooling mode temperature corresponds to:

- In the event of dehumidification request: maximum setpoint set for the request zone;
- In the event of dehumidification request and cooling request: setpoint set for the request zone, but limited by the calculated dew temperature.



The dew temperature is only calculated for adjustments above or equal to 15°C.

3.22 OUTDOOR UNIT TESTMODE FUNCTION

When test mode is used (see outdoor unit instruction booklet), the indoor unit must be set in a mode other than “Stand-by”.

The alarm E183 is triggered during the test, meaning “Test mode” in progress.

3.23 OUTDOOR UNIT PUMP DOWN FUNCTION

If the pump down function is used (see outdoor unit instruction booklet) the indoor unit must be set in “Stand-by”.

The function can only be activated if the appliance is not under alarm.

3.24 PUFFER IN PREHEATING FUNCTION

In the presence of an inertial storage tank heated by other sources of heat, following a central heating demand, it is possible to prevent the generators from being activated by using hot water coming from the puffer

The function is activated by setting one of the relays of the relay board at 4. (see P03, P04, P05).

The puffer function requires the puffer probe.

See the instruction sheet of the relay board for details and examples

3.25 NIGHT MODE FUNCTION

This function can be activated by setting the internal clock of the appliance (parameters U 21 and U 22).

Activating the function allows you to reduce the compressor frequency during the outdoor unit operation in the time slot set in the U 12 and U 13 parameters.

Make sure the additional power sources needed to meet potential requirements that may present themselves during active operation are available (e.g. additional resistances).

3.26 SYSTEM SETPOINT CORRECTION FUNCTION

In the presence of hydraulic disconnections on the system which separate the appliance from the zones, a function can be activated which allows to meet the demands, by correcting the appliance's setpoint.

The corrections can be made either in heating or cooling mode only.

They are activated by setting the parameters P 23 or P 24 at a value > 0°C.

Following a demand, the correction begins after a time equal to P 21 and continues by 1°C every P 22 minutes.

To connect the B3-1, B3-2 and B3-3 probes, please refer to the wiring diagram (Fig. 9):

To enable the setpoint correction on zone 1, it is necessary to set the parameter A27=ZN1.

3.27 HEATING/COOLING SELECTOR FUNCTION

The cooling/central heating selector function uses the S44 contact in combination with the zone 1 Room thermostat to make central heating/cooling requests to the machine using free contacts.

The type of demand, central heating or cooling, can be selected from the external selector S44, see Horizontal terminal block electrical connection diagram (Par. 1.9);

To use this command, the function in question must be enabled by means of the parameter A 39=ON.

To make the request, it is necessary to position the S44 selector as indicated in the following table:

S44Selector	Mode
Closed	Central heating
Open	Cooling

At the end, close the zone 1 Room thermostat contact.

The remote devices cannot be used when the function is enabled, except for the room thermostat of zone 1; even the demands of other zones, 2 or 3, are disabled automatically.

3.28 DHW RECIRCULATION FUNCTION

It is possible to manage DHW recirculation by activating the circulator based on a set schedule (see parameters U 32 and U 33).

The function is activated by selecting the relative function in parameters P 03, P 04 and P 05.

If U 32=U 33, the function is active all day.

For correct operation of recirculation it is necessary to install the relay board (optional kit).

3.29 CASINGREMOVAL

To facilitate indoor unit maintenance the casing can be completely removed as follows:

Lower grid (Fig. 41)

- Loosen the two screws (a).
- Press the hooks inwards, which block the lower grid (b).
- Remove the grid (b).

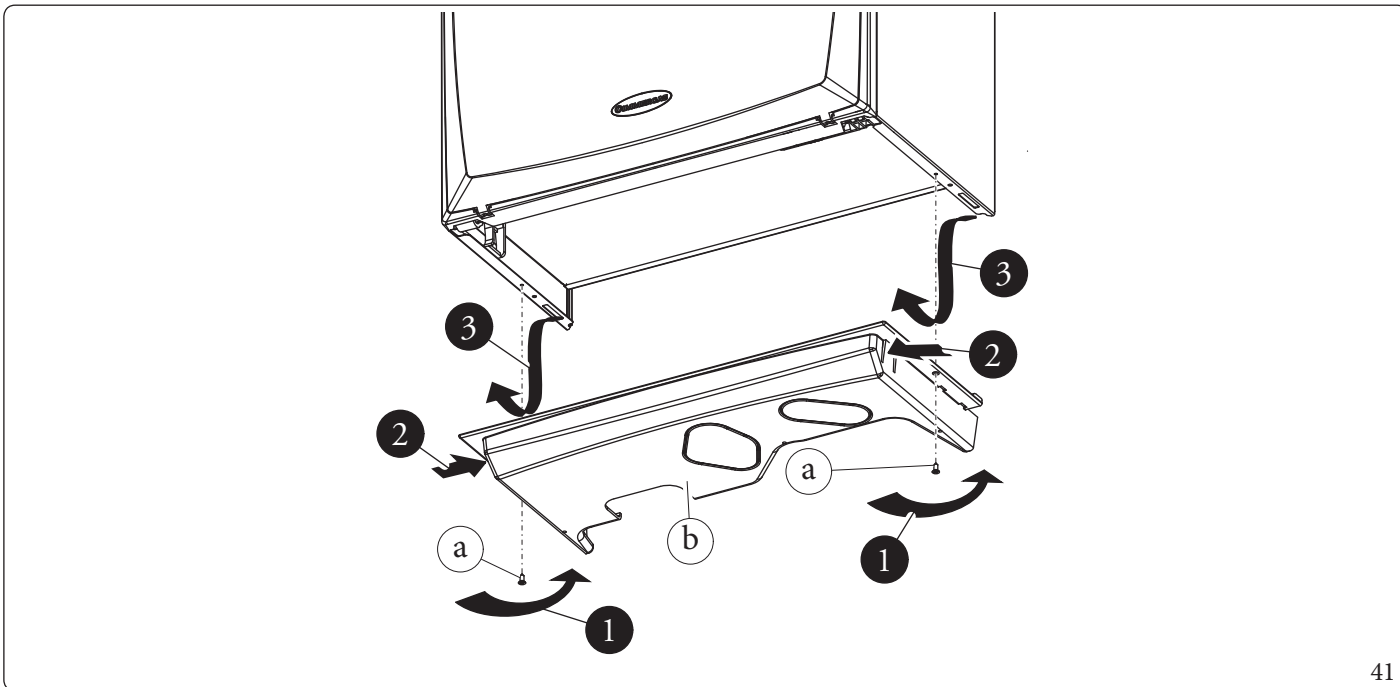

41

Front panel (Fig. 42)

- Open the protection door (e1) pulling it towards you.
- Remove the cover caps (c) and loosen screws (d).
- Pull the front panel (e) towards you and release it from its lower seat.

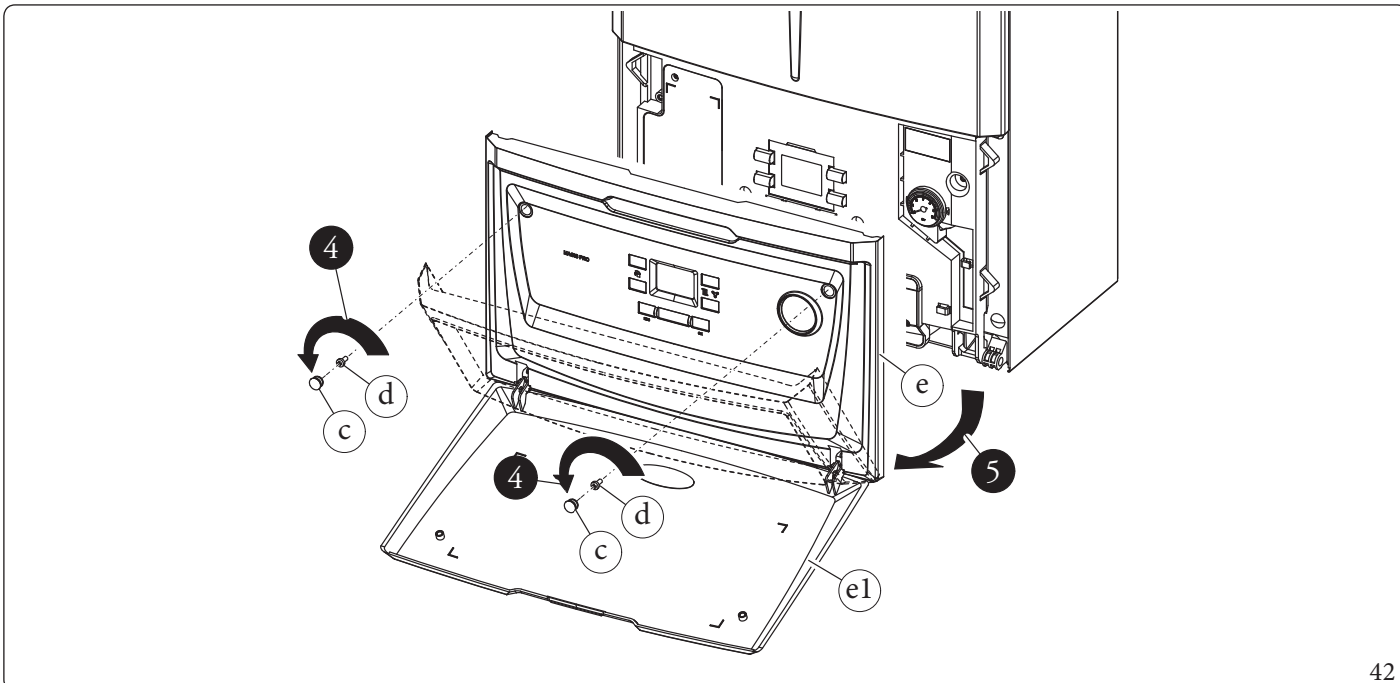

42

Front (Fig. 43)

- Loosen the two screws (g).
- Pull the front (f) slightly towards you.
- Release front (f) from pins (h) pulling it towards you while pushing it upwards at the same time.

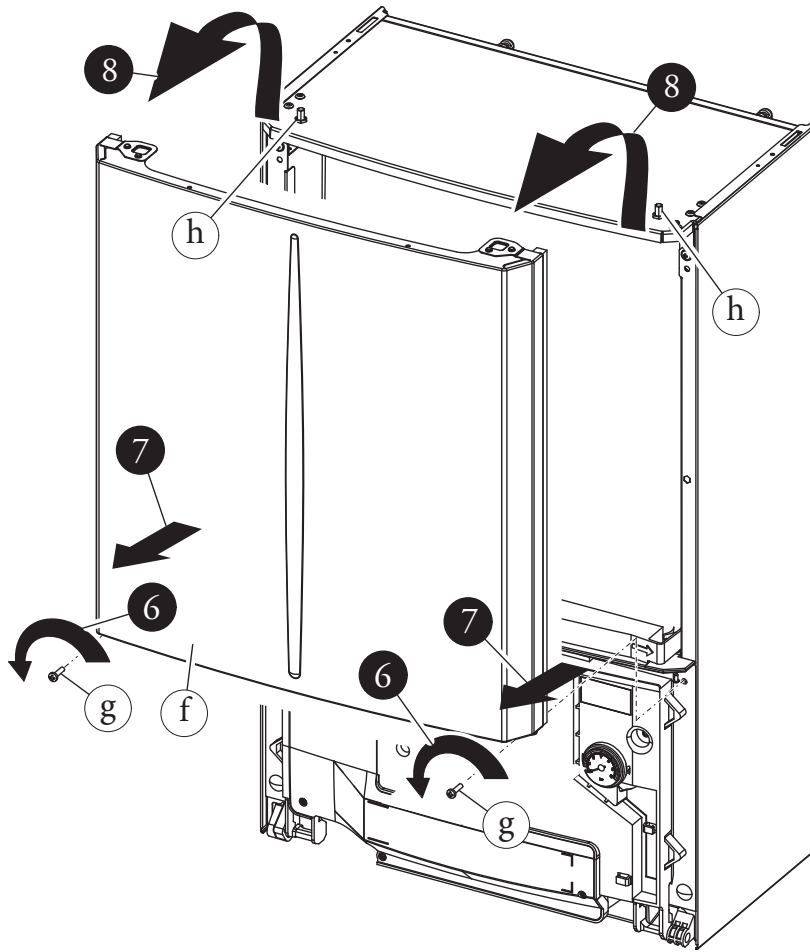

43

INSTALLER

USER

MAINTENANCE/TECHNICIAN

TECHNICAL DATA

Control panel (Fig. 44)

- Press the hooks on the side of the control panel (i).
- Tilt the control panel (i) towards you.

The control panel (i) can rotate until the support cord (j) is completely extended.

- If the left side needs to be removed, unhook the support cord (j) from the control panel and proceed as follows.

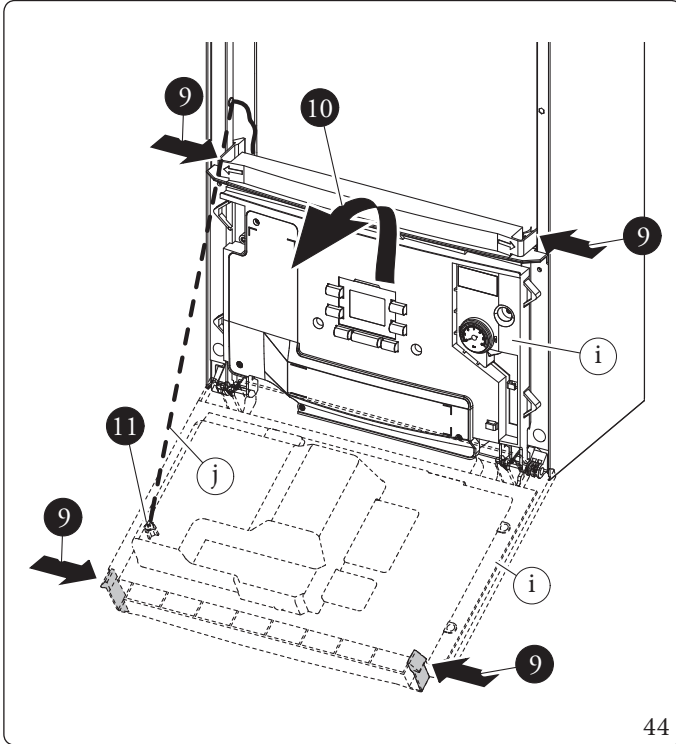

INTERFACE BOARD

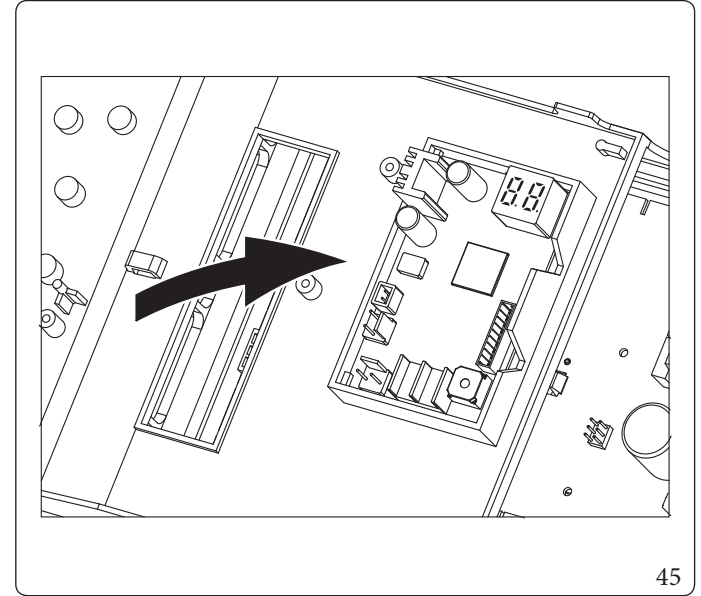

Sides (Fig. 46)

- Unscrew the side (k) fastening screws (l).
- Remove the sides by extracting them from their rear seat (Ref. X).

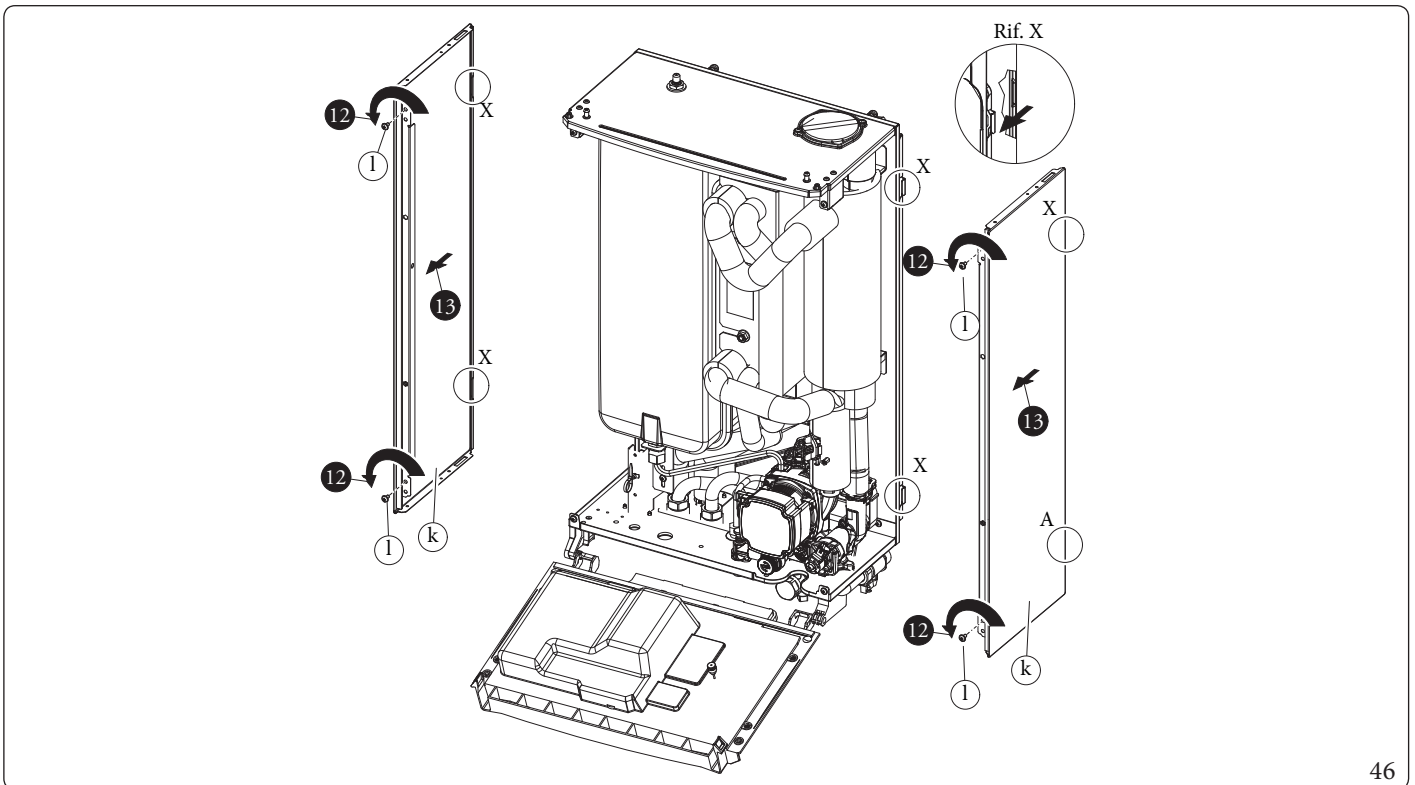

4 TECHNICAL DATA

4.1 TECHNICAL DATA TABLE

The data below refer to the pairing between indoor unit and outdoor unit.

		MAGIS PRO 4 V2	MAGIS PRO 6 V2	MAGIS PRO 9 V2
Nominal data for low temperature applications (A7/W35) *				
Nominal central heating output	kW	4,40	6,00	9,00
Absorption	kW	0,85	1,22	1,87
COP	kW/kW	5,20	4,92	4,81
Nominal data for low temperature applications (A35/W18) *				
Nominal cooling output	kW	5,00	6,50	8,70
Absorption	kW	1,09	1,47	2,11
EER	kW/kW	4,59	4,42	4,12
Nominal data for intermediate temperature applications (A7/W45) **				
Nominal central heating output	kW	4,20	5,40	8,60
Absorption	kW	1,09	1,51	2,33
COP	kW/kW	3,85	3,58	3,69
Nominal data for intermediate temperature applications (A35/W7) **				
Nominal cooling output	kW	3,60	4,70	6,50
Absorption	kW	1,11	1,44	1,95
EER	kW/kW	3,24	3,26	3,33
Nominal data for medium temperature applications (A7/W55) ***				
Nominal central heating output	kW	3,90	4,80	8,00
Absorption	kW	1,32	1,81	2,73
COP	kW/kW	2,95	2,65	2,93

* Central heating mode status: heat exchanger water inlet/remains at 30°C/35°C, outdoor air temperature 7°C db/6°C wb. Performance in compliance with EN 14511.

Cooling mode status: heat exchanger water inlet/remains at 23°C/18°C, outdoor air temperature 35°C. Performance in compliance with EN 14511.

* Central heating mode status: heat exchanger water inlet/remains at 40°C/45°C, outdoor air temperature 7°C db/6°C wb.

Cooling mode status: heat exchanger water inlet/remains at 12°C/7°C, outdoor air temperature 35°C. Performance in compliance with EN 14511.

*** Central heating mode status: inlet/remains at 47°C/55°C, outdoor air temperature 7°C db/6°C wb. Performance in compliance with EN 14511.

INSTALLER

USER

MAINTENANCE TECHNICIAN

TECHNICAL DATA

Indoor unit data

		MAGIS PRO 4 V2	MAGIS PRO 6 V2	MAGIS PRO 9 V2
Dimensions (Width x Height x Depth)	mm	440x760x250		
Maximum heating temperature	°C	70		
Adjustable central heating temperature (max operating field)	°C	20-65		
Cooling adjustable temperature (max. operating field)	°C	5-25		
Domestic hot water adjustable temperature	°C	10-55		
Domestic hot water adjustable temperature with DHW integration resistance (optional)	°C	10-65		
Water content	l	4,0		
Expansion vessel volume	l	12		
Expansion vessel pre-charged pressure	bar	1		
Hydraulic circuit max. operating pressure	bar	3		
Head available with 1000l/h flow rate	kPa (m.c.a.)	51,1(5,2)		

Electrical connection	V/Hz	230Vac, 50Hz		
Absorption without additional loads	W	70		
System integrative resistance absorption (optional)	kW	-		
Maximum relay current for zone pumps (inductive load)	A	1		
EER value	-	≤0,23 - Part. 3		
Equipment electrical system protection	-	IPX4D		
Ambient operating temperature range	°C	-5 ÷ +40		
Ambient operating temperature range with antifreeze kit (optional)	°C	-15 ÷ +40		
Empty hydronic unit weight	kg	35,8		
Full hydronic unit weight	kg	39,8		

Outdoor unit - Ambient operating temperature range.

		MAGIS PRO 4 V2	MAGIS PRO 6 V2	MAGIS PRO 9 V2
Room temperature in cooling mode	°C	10-46		
Room temperature in central heating mode	°C	-25..35		
Domestic hot water room temperature	°C	-25..35		
Domestic hot water room temperature with DHW integration resistance (optional)	°C	-25..46		

4.2 MAGIS PRO 4 V2 PRODUCT FICHE (IN COMPLIANCE WITH REGULATION 811/2013)

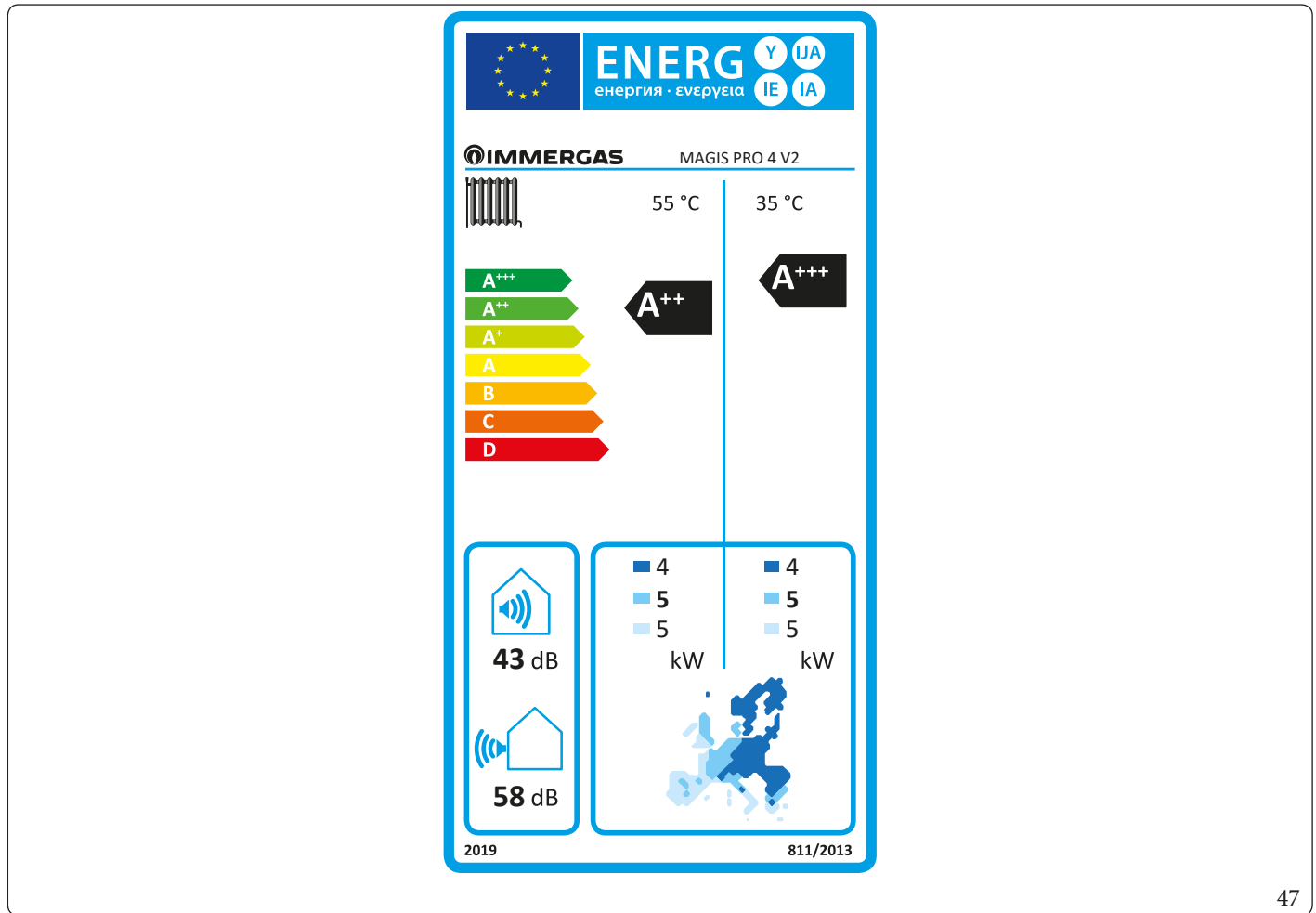

INSTALLER

USER

MAINTENANCE TECHNICIAN

TECHNICAL DATA

For proper installation of the appliance refer to chapter 1 of this booklet (for the installer) and current installation regulations. For proper maintenance refer to chapter 3 of this booklet (for the maintenance technician) and adhere to the frequencies and methods set out herein.

Low temperature (30/35)

Parameter	Value	Colder zones	Average zones	Hotter zones
Annual energy consumption for the central heating mode (Q_{HP})	kWh/year	2770	2253	1134
Room central heating seasonal efficiency (η_s)	η_s %	138	180	233
Nominal heat output	kW	4,00	5,00	5,00

Average temperature (47/55)

Parameter	Value	Colder zones	Average zones	Hotter zones
Annual energy consumption for the central heating mode (Q_{HP})	kWh/year	3992	3178	1753
Room central heating seasonal efficiency (η_s)	η_s %	96	127	149
Nominal heat output	kW	4,00	5,00	5,00

Average temperature table (47/55) average zones

Model		MAGIS PRO 4 V2					
Air/water heat pump	yes	Low temperature heat pump			no		
Water/water heat pump	no	With Supplementary heater			no		
Brine/water heat pump	no	Mixed central heating device with heat pump:			no		
The parameters are declared for average temperature application, except for low temperature heat pumps. The parameters for low temperature heat pumps are declared for low temperature application							
The parameters are declared for average climatic conditions							
Element	Symbol	Value	Unit	Element	Symbol	Value	Unit
Nominal heat output	$P_{nomi-nale}$	5,00	kW	Room central heating seasonal energy efficiency	η_s	127	%
Central heating capacity declared with a partial load and indoor temperature equivalent to 20°C and outdoor temperature T_j				Performance coefficient declared with indoor temperature equivalent to 20°C and outdoor temperature T_j			
$T_j = -7\text{ °C}$	Pdh	4,4	kW	$T_j = -7\text{ °C}$	COPd	2,10	-
$T_j = +2\text{ °C}$	Pdh	2,7	kW	$T_j = +2\text{ °C}$	COPd	3,10	-
$T_j = +7\text{ °C}$	Pdh	1,7	kW	$T_j = +7\text{ °C}$	COPd	4,46	-
$T_j = +12\text{ °C}$	Pdh	1,9	kW	$T_j = +12\text{ °C}$	COPd	5,72	-
$T_j = \text{bivalent temperature}$	Pdh	4,4	kW	$T_j = \text{bivalent temperature}$	COPd	2,10	-
$T_j = \text{operating limit temperature}$	Pdh	4,2	kW	$T_j = \text{operating limit temperature}$	COPd	1,51	-
for air/water heat pumps: $T_j = -15\text{ °C}$ (se TOL < -20°C)	Pdh	0,0	kW	for air/water heat pumps: $T_j = -15\text{ °C}$ (se TOL < -20°C)	COPd	0	-
Bivalent temperature	T_{biv}	-7	°C	For air/water heat pumps: Operating limit temperature	TOL	-10	°C
Central heating capacity cycle intervals	P_{ych}	0,0	kW	Cycle intervals efficiency	COP_{cyc} o PER_{cyc}	0	-
Degradation coefficient	C_{dh}	0,9	-	Water heating temperature operating limit	WTOL	0	°C
Different mode of energy consumption from the active mode				Supplementary heater			
OFF mode	P_{OFF}	0,022	kW	Nominal heat output	P_{sup}	2,00	kW
Thermostat mode off	P_{TO}	0,022	kW	Type of energy supply voltage	electrical		
Standby mode	P_{SB}	0,022	kW				
Guard heating mode	P_{CK}	0,000	kW				
Other items							
Capacity control	VARIABLE			For air/water heat pumps: nominal air output to outside	-	2400	m ³ /h
Indoor/outdoor sound level	L_{WA}	58	dB	For water or brine/water heat pumps: nominal flow of brine or water, outdoor heat exchanger	-	-	m ³ /h
Annual energy consumption	Q_{HE}	3178	kWh or GJ				
For mixed central heating appliances with a heat pump							
Stated load profile	-			Water central heating energy efficiency	η_{wh}	-	%
Daily electrical power consumption	Q_{elec}	-	kWh	Daily fuel consumption	Q_{fuel}	-	kWh
Annual energy consumption	AEC	-	kWh	Annual fuel consumption	AFC	-	GJ
Contact information	Immergas S.p.A. via Cisa Ligure n.95						

4.3 MAGIS PRO 6 V2 PRODUCT FICHE (IN COMPLIANCE WITH REGULATION 811/2013)

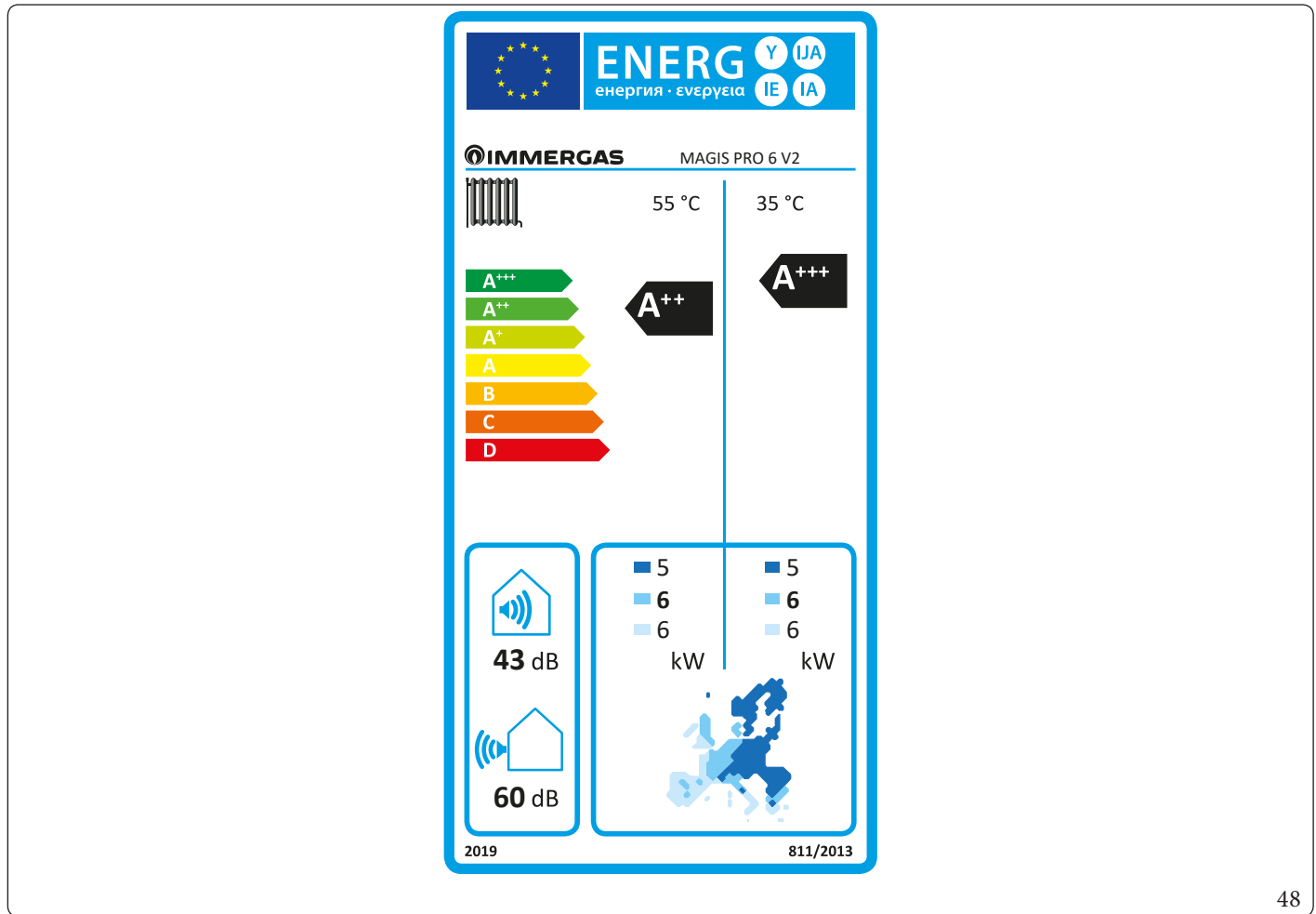

INSTALLER

USER

MAINTENANCE TECHNICIAN

TECHNICAL DATA

48

For proper installation of the appliance refer to chapter 1 of this booklet (for the installer) and current installation regulations. For proper maintenance refer to chapter 3 of this booklet (for the maintenance technician) and adhere to the frequencies and methods set out herein.

Low temperature (30/35)

Parameter	Value	Colder zones	Average zones	Hotter zones
Annual energy consumption for the central heating mode (Q_{HP})	kWh/year	3305	2705	1264
Room central heating seasonal efficiency (η_s)	η_s %	140	180	234
Nominal heat output	kW	5,00	6,00	6,00

Average temperature (47/55)

Parameter	Value	Colder zones	Average zones	Hotter zones
Annual energy consumption for the central heating mode (Q_{HP})	kWh/year	4951	3745	1953
Room central heating seasonal efficiency (η_s)	η_s %	93	129	150
Nominal heat output	kW	5,00	6,00	6,00

Average temperature table (47/55) average zones

Model		MAGIS PRO 6 V2					
Air/water heat pump	yes	Low temperature heat pump			no		
Water/water heat pump	no	With Supplementary heater			no		
Brine/water heat pump	no	Mixed central heating device with heat pump:			no		
The parameters are declared for average temperature application, except for low temperature heat pumps. The parameters for low temperature heat pumps are declared for low temperature application							
The parameters are declared for average climatic conditions							
Element	Symbol	Value	Unit	Element	Symbol	Value	Unit
Nominal heat output	$P_{nomi-nale}$	6,00	kW	Room central heating seasonal energy efficiency	η_s	-	%
Central heating capacity declared with a partial load and indoor temperature equivalent to 20°C and outdoor temperature T_j				Performance coefficient declared with indoor temperature equivalent to 20°C and outdoor temperature T_j			
$T_j = -7\text{ °C}$	Pdh	5,3	kW	$T_j = -7\text{ °C}$	COPd	2,00	-
$T_j = +2\text{ °C}$	Pdh	3,2	kW	$T_j = +2\text{ °C}$	COPd	3,23	-
$T_j = +7\text{ °C}$	Pdh	2,1	kW	$T_j = +7\text{ °C}$	COPd	4,47	-
$T_j = +12\text{ °C}$	Pdh	1,9	kW	$T_j = +12\text{ °C}$	COPd	5,82	-
$T_j =$ bivalent temperature	Pdh	5,3	kW	$T_j =$ bivalent temperature	COPd	2,00	-
$T_j =$ operating limit temperature	Pdh	5,0	kW	$T_j =$ operating limit temperature	COPd	1,80	-
for air/water heat pumps: $T_j = -15\text{ °C}$ (se TOL < -20°C)	Pdh	0,0	kW	for air/water heat pumps: $T_j = -15\text{ °C}$ (se TOL < -20°C)	COPd	0	-
Bivalent temperature	T_{biv}	-7	°C	For air/water heat pumps: Operating limit temperature	TOL	-10	°C
Central heating capacity cycle intervals	Pcyc	0,0	kW	Cycle intervals efficiency	COPcyc o PERcyc	0	-
Degradation coefficient	Cdh	0,9	-	Water heating temperature operating limit	WTOL	0	°C
Different mode of energy consumption from the active mode				Supplementary heater			
OFF mode	P_{OFF}	0,022	kW	Nominal heat output	P_{sup}	2,00	kW
Thermostat mode off	P_{TO}	0,022	kW	Type of energy supply voltage	electrical		
Standby mode	P_{SB}	0,022	kW				
Guard heating mode	P_{CK}	0,000	kW				
Other items							
Capacity control	VARIABLE			For air/water heat pumps: nominal air output to outside	-	2580	m ³ /h
Indoor/outdoor sound level	L_{WA}	60	dB	For water or brine/water heat pumps: nominal flow of brine or water, outdoor heat exchanger	-	-	m ³ /h
Annual energy consumption	Q_{HE}	3745	kWh or GJ				
For mixed central heating appliances with a heat pump							
Stated load profile	-			Water central heating energy efficiency	η_{wh}	-	%
Daily electrical power consumption	Q_{elec}	-	kWh	Daily fuel consumption	Q_{fuel}	-	kWh
Annual energy consumption	AEC	-	kWh	Annual fuel consumption	AFC	-	GJ
Contact information	Immergas S.p.A. via Cisa Ligure n.95						

4.4 MAGIS PRO 9 V2 PRODUCT FICHE (IN COMPLIANCE WITH REGULATION 811/2013)

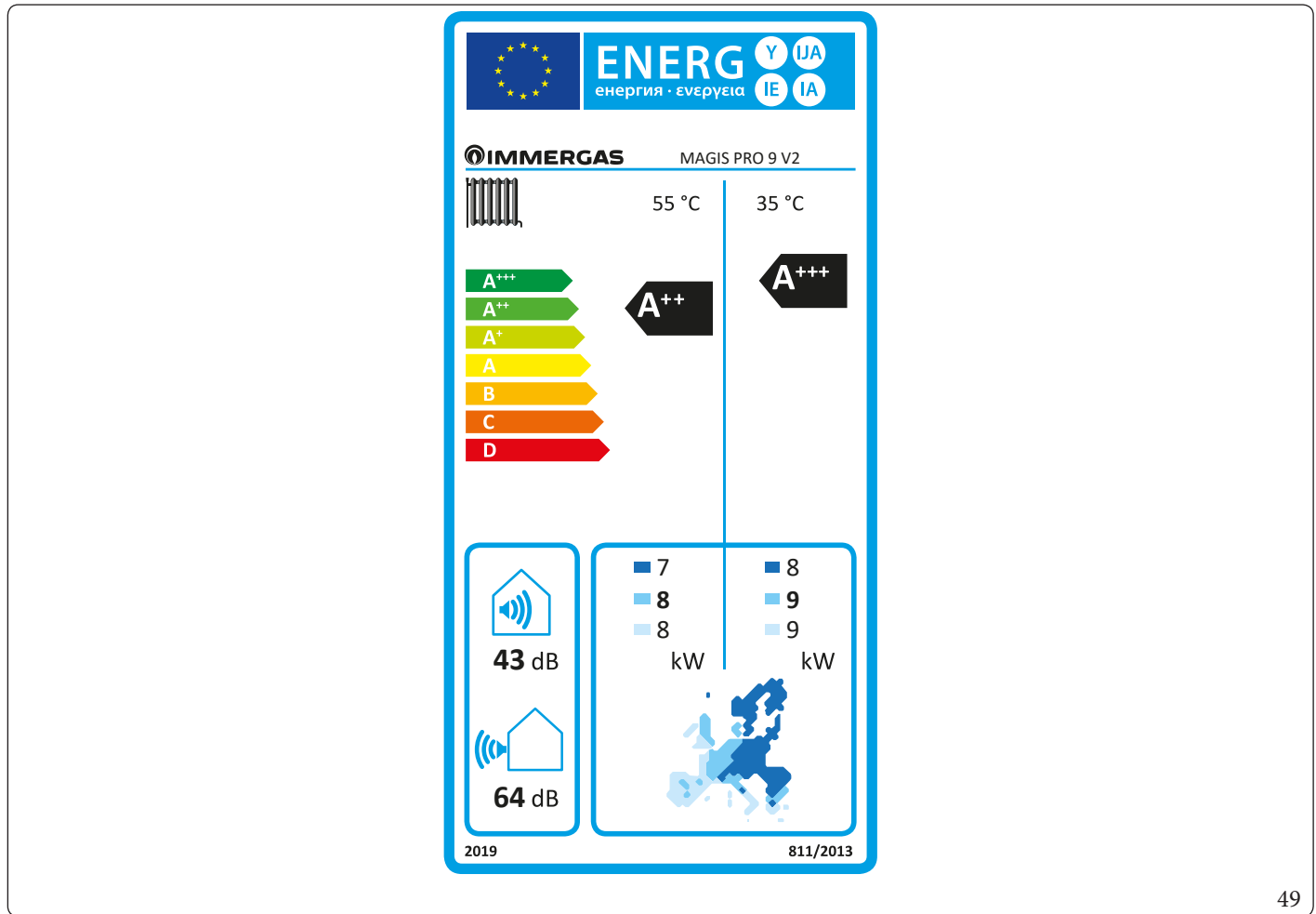

INSTALLER

USER

MAINTENANCE TECHNICIAN

TECHNICAL DATA

For proper installation of the appliance refer to chapter 1 of this booklet (for the installer) and current installation regulations. For proper maintenance refer to chapter 3 of this booklet (for the maintenance technician) and adhere to the frequencies and methods set out herein.

Low temperature (30/35)

Parameter	Value	Colder zones	Average zones	Hotter zones
Annual energy consumption for the central heating mode (Q_{HP})	kWh/year	5252	3949	1865
Room central heating seasonal efficiency (η_s)	η_s %	138	175	241
Nominal heat output	kW	8,00	9,00	9,00

Average temperature (47/55)

Parameter	Value	Colder zones	Average zones	Hotter zones
Annual energy consumption for the central heating mode (Q_{HP})	kWh/year	7220	5103	2720
Room central heating seasonal efficiency (η_s)	η_s %	93	127	154
Nominal heat output	kW	7,00	8,00	8,00

Average temperature table (47/55) average zones

Model		MAGISPRO9 V2					
Air/water heat pump	yes	Low temperature heat pump			no		
Water/water heat pump	no	With Supplementary heater			no		
Brine/water heat pump	no	Mixed central heating device with heat pump:			no		
The parameters are declared for average temperature application, except for low temperature heat pumps. The parameters for low temperature heat pumps are declared for low temperature application							
The parameters are declared for average climatic conditions							
Element	Symbol	Value	Unit	Element	Symbol	Value	Unit
Nominal heat output	$P_{nomi-nale}$	8,00	kW	Room central heating seasonal energy efficiency	η_s	-	%
Central heating capacity declared with a partial load and indoor temperature equivalent to 20°C and outdoor temperature T_j				Performance coefficient declared with indoor temperature equivalent to 20°C and outdoor temperature T_j			
$T_j = -7\text{ °C}$	Pdh	7,1	kW	$T_j = -7\text{ °C}$	COPd	1,76	-
$T_j = +2\text{ °C}$	Pdh	4,3	kW	$T_j = +2\text{ °C}$	COPd	3,32	-
$T_j = +7\text{ °C}$	Pdh	2,8	kW	$T_j = +7\text{ °C}$	COPd	4,62	-
$T_j = +12\text{ °C}$	Pdh	2,6	kW	$T_j = +12\text{ °C}$	COPd	5,88	-
$T_j = \text{bivalent temperature}$	Pdh	7,1	kW	$T_j = \text{bivalent temperature}$	COPd	1,76	-
$T_j = \text{operating limit temperature}$	Pdh	4,9	kW	$T_j = \text{operating limit temperature}$	COPd	1,35	-
for air/water heat pumps: $T_j = -15\text{ °C}$ (se TOL < -20°C)	Pdh	0,0	kW	for air/water heat pumps: $T_j = -15\text{ °C}$ (se TOL < -20°C)	COPd	0	-
Bivalent temperature	T_{biv}	-7	°C	For air/water heat pumps: Operating limit temperature	TOL	-10	°C
Central heating capacity cycle intervals	Pcyh	0,0	kW	Cycle intervals efficiency	COPcyc o PERcyc	0	-
Degradation coefficient	Cdh	0,9	-	Water heating temperature operating limit	WTOL	0	°C
Different mode of energy consumption from the active mode				Supplementary heater			
OFF mode	P_{OFF}	0,022	kW	Nominal heat output	P_{sup}	2,00	kW
Thermostat mode off	P_{TO}	0,022	kW	Type of energy supply voltage	electrical		
Standby mode	P_{SB}	0,022	kW				
Guard heating mode	P_{CK}	0,000	kW				
Other items							
Capacity control	VARIABLE			For air/water heat pumps: nominal air output to outside	-	3960	m ³ /h
Indoor/outdoor sound level	L_{WA}	64	dB	For water or brine/water heat pumps: nominal flow of brine or water, outdoor heat exchanger	-	-	m ³ /h
Annual energy consumption	Q_{HE}	5103	kWh or GJ				
For mixed central heating appliances with a heat pump							
Stated load profile	-			Water central heating energy efficiency	η_{wh}	-	%
Daily electrical power consumption	Q_{elec}	-	kWh	Daily fuel consumption	Q_{fuel}	-	kWh
Annual energy consumption	AEC	-	kWh	Annual fuel consumption	AFC	-	GJ
Contact information	Immergas S.p.A. via Cisa Ligure n.95						

4.5 MAGIS PRO 4 V2 PRODUCT FICHE PAIRED WITH SUPER TRIO (IN COMPLIANCE WITH REGULATION 811/2013)

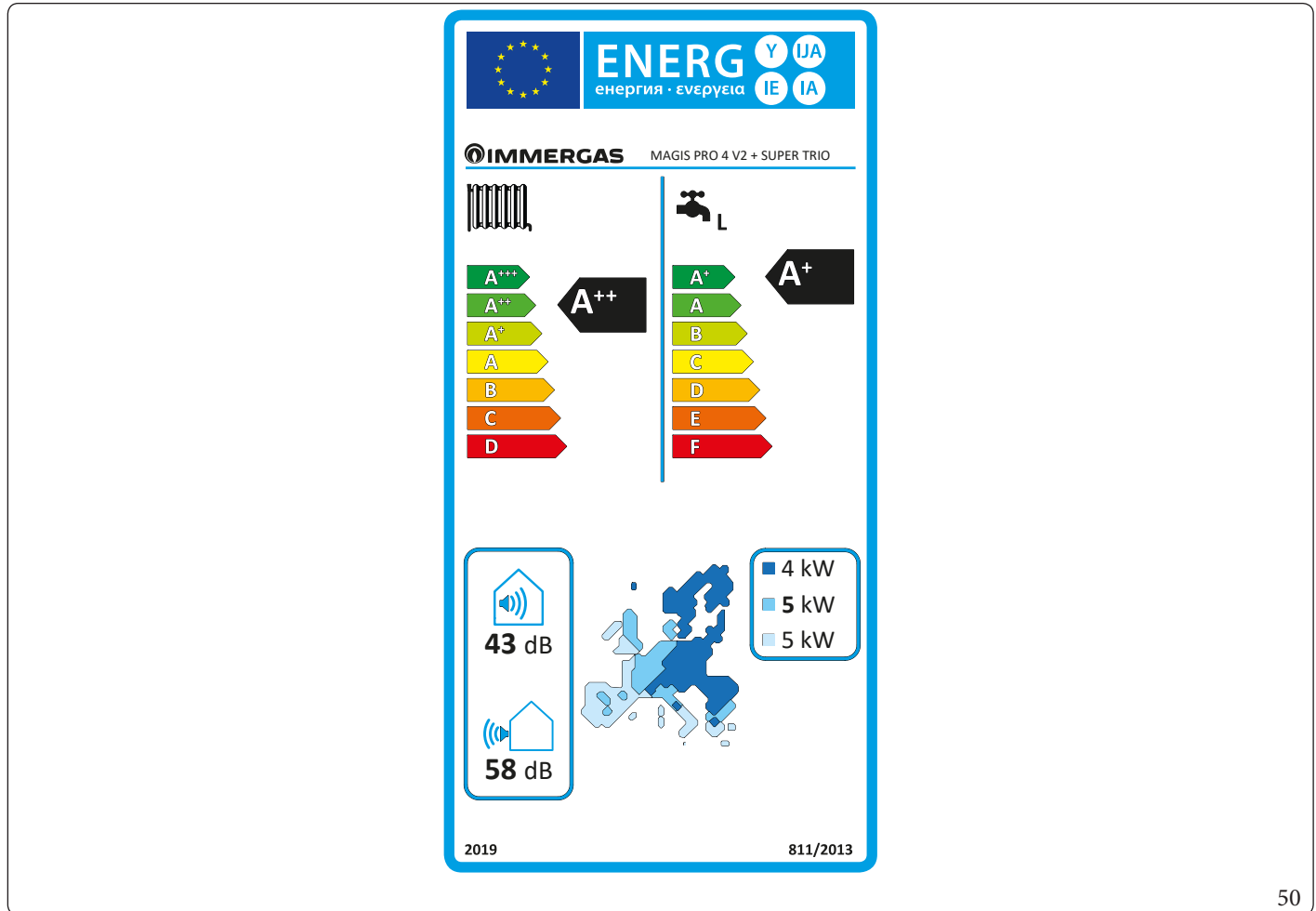

INSTALLER

USER

MAINTENANCE TECHNICIAN

TECHNICAL DATA

50

For proper installation of the appliance refer to chapter 1 of this booklet (for the installer) and current installation regulations. For proper maintenance refer to chapter 3 of this booklet (for the maintenance technician) and adhere to the frequencies and methods set out herein.

Low temperature (30/35)

Parameter	Value	Colder zones	Average zones	Hotter zones
		■	■	■
Annual energy consumption for the central heating mode (Q_{HE})	kWh/year	2770	2253	1134
Room central heating seasonal efficiency (η_s)	η_s %	138	180	233
Nominal heat output	kW	4,00	5,00	5,00

Average temperature (47/55)

Parameter	Value	Colder zones	Average zones	Hotter zones
		■	■	■
Annual energy consumption for the central heating mode (Q_{HE})	kWh/year	3992	3178	1753
Room central heating seasonal efficiency (η_s)	η_s %	96	127	149
Nominal heat output	kW	4,00	5,00	5,00

Average temperature table (47/55) average zones

Model		MAGIS PRO 4 V2 + SUPER TRIO					
Air/water heat pump	yes	Low temperature heat pump				no	
Water/water heat pump	no	With Supplementary heater				no	
Brine/water heat pump	no	Mixed central heating device with heat pump:				yes	
The parameters are declared for average temperature application, except for low temperature heat pumps. The parameters for low temperature heat pumps are declared for low temperature application							
The parameters are declared for average climatic conditions							
Element	Symbol	Value	Unit	Element	Symbol	Value	Unit
Nominal heat output	$P_{nomi-nale}$	5,00	kW	Room central heating seasonal energy efficiency	η_s	127	%
Central heating capacity declared with a partial load and indoor temperature equivalent to 20°C and outdoor temperature T_j				Performance coefficient declared with indoor temperature equivalent to 20°C and outdoor temperature T_j			
$T_j = -7\text{ °C}$	Pdh	4,4	kW	$T_j = -7\text{ °C}$	COPd	2,10	-
$T_j = +2\text{ °C}$	Pdh	2,7	kW	$T_j = +2\text{ °C}$	COPd	3,10	-
$T_j = +7\text{ °C}$	Pdh	1,7	kW	$T_j = +7\text{ °C}$	COPd	4,46	-
$T_j = +12\text{ °C}$	Pdh	1,9	kW	$T_j = +12\text{ °C}$	COPd	5,72	-
$T_j = \text{bivalent temperature}$	Pdh	4,4	kW	$T_j = \text{bivalent temperature}$	COPd	2,10	-
$T_j = \text{operating limit temperature}$	Pdh	4,2	kW	$T_j = \text{operating limit temperature}$	COPd	1,51	-
for air/water heat pumps: $T_j = -15\text{ °C}$ (se TOL < -20°C)	Pdh	0,0	kW	for air/water heat pumps: $T_j = -15\text{ °C}$ (se TOL < -20°C)	COPd	0	-
Bivalent temperature	T_{biv}	-7	°C	For air/water heat pumps: Operating limit temperature	TOL	-10	°C
Central heating capacity cycle intervals	P_{ych}	0,0	kW	Cycle intervals efficiency	COP_{cyc} o PER_{cyc}	0	-
Degradation coefficient	C_{dh}	0,9	-	Water heating temperature operating limit	WTOL	0	°C
Different mode of energy consumption from the active mode				Supplementary heater			
OFF mode	P_{OFF}	0,022	kW	Nominal heat output	P_{sup}	2,00	kW
Thermostat mode off	P_{TO}	0,022	kW	Type of energy supply voltage	electrical		
Standby mode	P_{SB}	0,022	kW				
Guard heating mode	P_{CK}	0,000	kW				
Other items							
Capacity control	VARIABLE			For air/water heat pumps: nominal air output to outside	-	2400	m ³ /h
Indoor/outdoor sound level	L_{WA}	58	dB	For water or brine/water heat pumps: nominal flow of brine or water, outdoor heat exchanger	-	-	m ³ /h
Annual energy consumption	Q_{HE}	3178	kWh or GJ				
For mixed central heating appliances with a heat pump							
Stated load profile	L			Water central heating energy efficiency	η_{wh}	118,0	%
Daily electrical power consumption	Q_{elec}	4,20	kWh	Daily fuel consumption	Q_{fuel}	-	kWh
Annual energy consumption	AEC	869	kWh	Annual fuel consumption	AFC	-	GJ
Contact information	Immergas S.p.A. via Cisa Ligure n.95						

4.6 MAGIS PRO 6 V2 PRODUCT FICHE PAIRED WITH SUPER TRIO (IN COMPLIANCE WITH REGULATION 811/2013)

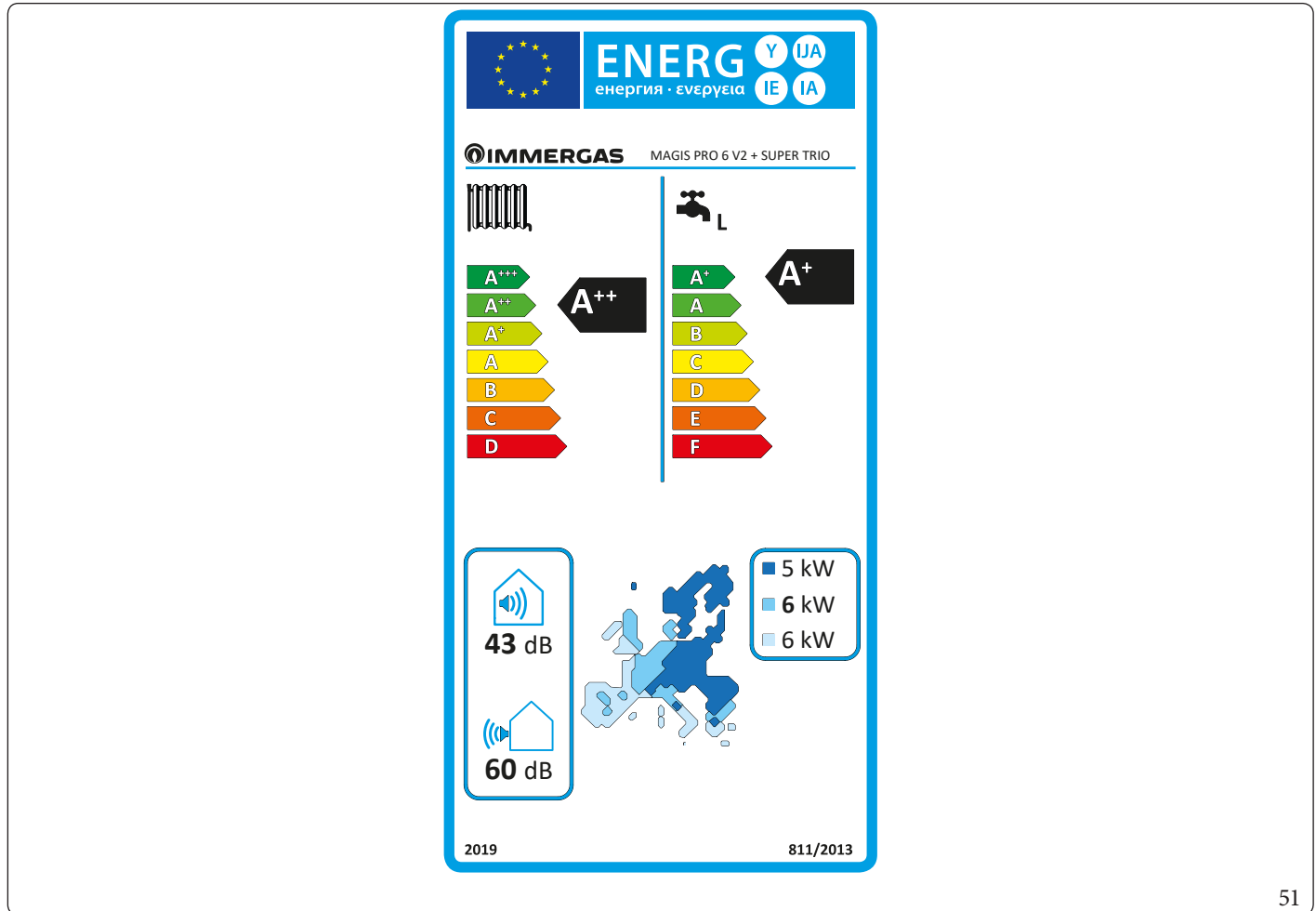

INSTALLER

USER

MAINTENANCE TECHNICIAN

TECHNICAL DATA

51

For proper installation of the appliance refer to chapter 1 of this booklet (for the installer) and current installation regulations. For proper maintenance refer to chapter 3 of this booklet (for the maintenance technician) and adhere to the frequencies and methods set out herein.

Low temperature (30/35)

Parameter	Value	Colder zones	Average zones	Hotter zones
Annual energy consumption for the central heating mode (Q_{HE})	kWh/year	3305	2705	1264
Room central heating seasonal efficiency (η_s)	η_s %	140	180	234
Nominal heat output	kW	5,00	6,00	6,00

Average temperature (47/55)

Parameter	Value	Colder zones	Average zones	Hotter zones
Annual energy consumption for the central heating mode (Q_{HE})	kWh/year	4951	3745	1953
Room central heating seasonal efficiency (η_s)	η_s %	93	129	150
Nominal heat output	kW	5,00	6,00	6,00

Average temperature table (47/55) average zones

Model		MAGIS PRO 6 V2 + SUPER TRIO					
Air/water heat pump	yes	Low temperature heat pump				no	
Water/water heat pump	no	With Supplementary heater				no	
Brine/water heat pump	no	Mixed central heating device with heat pump:				yes	
The parameters are declared for average temperature application, except for low temperature heat pumps. The parameters for low temperature heat pumps are declared for low temperature application							
The parameters are declared for average climatic conditions							
Element	Symbol	Value	Unit	Element	Symbol	Value	Unit
Nominal heat output	$P_{nomi-nale}$	6,00	kW	Room central heating seasonal energy efficiency	η_s	129	%
Central heating capacity declared with a partial load and indoor temperature equivalent to 20°C and outdoor temperature T_j				Performance coefficient declared with indoor temperature equivalent to 20°C and outdoor temperature T_j			
$T_j = -7\text{ °C}$	Pdh	5,3	kW	$T_j = -7\text{ °C}$	COPd	2,00	-
$T_j = +2\text{ °C}$	Pdh	3,2	kW	$T_j = +2\text{ °C}$	COPd	3,23	-
$T_j = +7\text{ °C}$	Pdh	2,1	kW	$T_j = +7\text{ °C}$	COPd	4,47	-
$T_j = +12\text{ °C}$	Pdh	1,9	kW	$T_j = +12\text{ °C}$	COPd	5,82	-
$T_j = \text{bivalent temperature}$	Pdh	5,3	kW	$T_j = \text{bivalent temperature}$	COPd	2,00	-
$T_j = \text{operating limit temperature}$	Pdh	5,0	kW	$T_j = \text{operating limit temperature}$	COPd	1,80	-
for air/water heat pumps: $T_j = -15\text{ °C}$ (se TOL < -20°C)	Pdh	0,0	kW	for air/water heat pumps: $T_j = -15\text{ °C}$ (se TOL < -20°C)	COPd	0	-
Bivalent temperature	T_{biv}	-7	°C	For air/water heat pumps: Operating limit temperature	TOL	-10	°C
Central heating capacity cycle intervals	P_{cyc}	0,0	kW	Cycle intervals efficiency	COP_{cyc} o PER_{cyc}	0	-
Degradation coefficient	C_{dh}	0,9	-	Water heating temperature operating limit	WTOL	0	°C
Different mode of energy consumption from the active mode				Supplementary heater			
OFF mode	P_{OFF}	0,022	kW	Nominal heat output	P_{sup}	2,00	kW
Thermostat mode off	P_{TO}	0,022	kW	Type of energy supply voltage	electrical		
Standby mode	P_{SB}	0,022	kW				
Guard heating mode	P_{CK}	0,000	kW				
Other items							
Capacity control	VARIABLE			For air/water heat pumps: nominal air output to outside	-	2580	m ³ /h
Indoor/outdoor sound level	L_{WA}	60	dB	For water or brine/water heat pumps: nominal flow of brine or water, outdoor heat exchanger	-	-	m ³ /h
Annual energy consumption	Q_{HE}	3745	kWh or GJ				
For mixed central heating appliances with a heat pump							
Stated load profile	L			Water central heating energy efficiency	η_{wh}	121,0	%
Daily electrical power consumption	Q_{elec}	4,11	kWh	Daily fuel consumption	Q_{fuel}	-	kWh
Annual energy consumption	AEC	849	kWh	Annual fuel consumption	AFC	-	GJ
Contact information	Immergas S.p.A. via Cisa Ligure n.95						

4.7 MAGIS PRO 9 V2 PRODUCT FICHE PAIRED WITH SUPER TRIO (IN COMPLIANCE WITH REGULATION 811/2013)

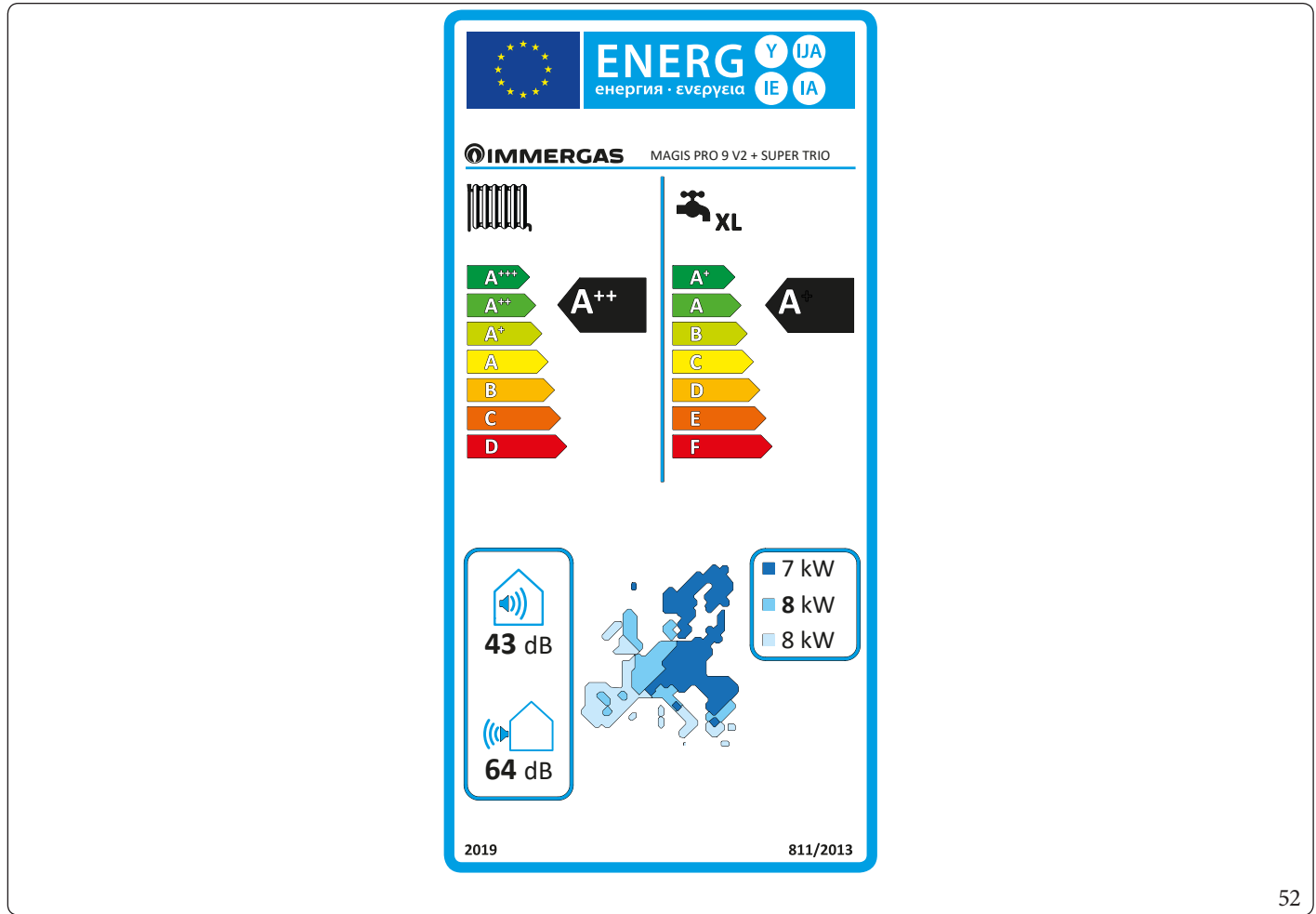

INSTALLER

USER

MAINTENANCE TECHNICIAN

TECHNICAL DATA

52

For proper installation of the appliance refer to chapter 1 of this booklet (for the installer) and current installation regulations. For proper maintenance refer to chapter 3 of this booklet (for the maintenance technician) and adhere to the frequencies and methods set out herein.

Low temperature (30/35)

Parameter	Value	Colder zones	Average zones	Hotter zones
		■	■	■
Annual energy consumption for the central heating mode (Q_{HE})	kWh/year	5252	3949	1865
Room central heating seasonal efficiency (η_s)	η_s %	138	175	241
Nominal heat output	kW	8,00	9,00	9,00

Average temperature (47/55)

Parameter	Value	Colder zones	Average zones	Hotter zones
		■	■	■
Annual energy consumption for the central heating mode (Q_{HE})	kWh/year	7220	5103	2720
Room central heating seasonal efficiency (η_s)	η_s %	93	127	154
Nominal heat output	kW	7,00	8,00	8,00

Average temperature table (47/55) average zones

Model		MAGIS PRO 9 V2 + SUPER TRIO					
Air/water heat pump	yes	Low temperature heat pump				no	
Water/water heat pump	no	With Supplementary heater				no	
Brine/water heat pump	no	Mixed central heating device with heat pump:				yes	
The parameters are declared for average temperature application, except for low temperature heat pumps. The parameters for low temperature heat pumps are declared for low temperature application							
The parameters are declared for average climatic conditions							
Element	Symbol	Value	Unit	Element	Symbol	Value	Unit
Nominal heat output	$P_{nomi-nale}$	8,00	kW	Room central heating seasonal energy efficiency	η_s	127	%
Central heating capacity declared with a partial load and indoor temperature equivalent to 20°C and outdoor temperature T_j				Performance coefficient declared with indoor temperature equivalent to 20°C and outdoor temperature T_j			
$T_j = -7\text{ °C}$	Pdh	7,1	kW	$T_j = -7\text{ °C}$	COPd	1,76	-
$T_j = +2\text{ °C}$	Pdh	4,3	kW	$T_j = +2\text{ °C}$	COPd	3,32	-
$T_j = +7\text{ °C}$	Pdh	2,8	kW	$T_j = +7\text{ °C}$	COPd	4,62	-
$T_j = +12\text{ °C}$	Pdh	2,6	kW	$T_j = +12\text{ °C}$	COPd	5,88	-
$T_j =$ bivalent temperature	Pdh	7,1	kW	$T_j =$ bivalent temperature	COPd	1,76	-
$T_j =$ operating limit temperature	Pdh	4,9	kW	$T_j =$ operating limit temperature	COPd	1,35	-
for air/water heat pumps: $T_j = -15\text{ °C}$ (se TOL < -20°C)	Pdh	0,0	kW	for air/water heat pumps: $T_j = -15\text{ °C}$ (se TOL < -20°C)	COPd	0	-
Bivalent temperature	T_{biv}	-7	°C	For air/water heat pumps: Operating limit temperature	TOL	-10	°C
Central heating capacity cycle intervals	Pcyh	0,0	kW	Cycle intervals efficiency	COPcyc o PERcyc	0	-
Degradation coefficient	Cdh	0,9	-	Water heating temperature operating limit	WTOL	0	°C
Different mode of energy consumption from the active mode				Supplementary heater			
OFF mode	P_{OFF}	0,022	kW	Nominal heat output	P_{sup}	2,00	kW
Thermostat mode off	P_{TO}	0,022	kW	Type of energy supply voltage	electrical		
Standby mode	P_{SB}	0,022	kW				
Guard heating mode	P_{CK}	0,000	kW				
Other items							
Capacity control	VARIABLE			For air/water heat pumps: nominal air output to outside	-	3960	m ³ /h
Indoor/outdoor sound level	L_{WA}	64	dB	For water or brine/water heat pumps: nominal flow of brine or water, outdoor heat exchanger	-	-	m ³ /h
Annual energy consumption	Q_{HE}	5103	kWh or GJ				
For mixed central heating appliances with a heat pump							
Stated load profile	XL			Water central heating energy efficiency	η_{wh}	111,0	%
Daily electrical power consumption	Q_{elec}	7,14	kWh	Daily fuel consumption	Q_{fuel}	-	kWh
Annual energy consumption	AEC	1511	kWh	Annual fuel consumption	AFC	-	GJ
Contact information	Immergas S.p.A. via Cisa Ligure n.95						

4.8 PARAMETERS FOR FILLING IN THE PACKAGE FICHE

Should you wish to install an assembly starting from the Magis Pro V2 package, use the package fiche shown in (Fig. 54). To complete it properly, fill the relevant spaces (as shown in the package fiche facsimile Fig. 53) with the values shown in tables "Parameters to fill in the low temperature package fiche (30/35)", "Parameters to fill in the average temperature package fiche (47/55)". The remaining values must be obtained from the technical data sheets of the products used to make up the assembly (e.g. solar devices, integration hydronic module, temperature controllers). Use board (Fig. 54) for "assemblies" related to the central heating mode (e.g.: heat pump + temperature controller).



Since the product is standard supplied with a temperature controller, the package fiche must always be completed.

Facsimile for filling in the package fiche for room central heating systems.

Room central heating seasonal energy efficiency of the heat pump %

Temperature control %
 From temperature control board

Class I = 1 %, Class II = 2 %,
 Class III = 1.5 %, Class IV = 2 %,
 Class V = 3 %, Class VI = 4 %,
 Class VII = 3.5 %, Class VIII = 5 %

Supplementary boiler %
 From boiler board

Seasonal central heating energy efficiency of the room (%)

$$\left(\text{[]} - \text{'I'} \right) \times \text{'II'} = - \text{[]} \%$$

Solar contribution
 From the board of the solar device

Dimensions of the manifold (in m²)

Volume of the tank (in m³)

Efficiency of the manifold (in %)

Classification of the tank
 A* = 0.95, A = 0.91,
 B = 0.86, C = 0.83,
 D-G = 0.81

$$\left(\text{'III'} \times \text{[]} + \text{'IV'} \times \text{[]} \right) \times 0.45 \times \left(\text{[]} / 100 \right) \times \text{[]} = + \text{[]} \%$$

Room central heating seasonal energy efficiency of the assemble in average climate conditions %

Room central heating seasonal energy efficiency class of the assemble in average climate conditions

□	□	□	□	□	□	□	□	□	□
G	F	E	D	C	B	A	A⁺	A⁺⁺	A⁺⁺⁺
< 30 %	≥ 30 %	≥ 34 %	≥ 36 %	≥ 75 %	≥ 82 %	≥ 90 %	≥ 98 %	≥ 125 %	≥ 150 %

Room central heating seasonal energy efficiency in colder and hotter climate conditions

Colder: - 'V' = % Hotter: + 'VI' = %

The energy efficiency of the set of products indicated in this sheet may not reflect the actual energy efficiency after installation since such efficiency is affected by additional factors, such as the heat loss in the distribution system and the size of the products compared to the size and features of the building.

Parameters to fill in the low temperature package fiche (30/35)

Magis PRO 4 V2

Parameter	Colder zones	Average zones	Hotter zones
	■	■	■
"I"	138	180	233
"II"	*	*	*
"III"	6,68	5,35	5,35
"IV"	2,61	2,09	2,09

Magis PRO 6 V2

Parameter	Colder zones	Average zones	Hotter zones
	■	■	■
"I"	140	180	234
"II"	*	*	*
"III"	5,35	4,45	4,45
"IV"	2,09	1,74	1,74

Magis PRO 9 V2

Parameter	Colder zones	Average zones	Hotter zones
	■	■	■
"I"	138	175	241
"II"	*	*	*
"III"	3,34	2,97	2,97
"IV"	1,31	1,16	1,16

* to be determined according to Regulation 811/2013 and transient calculation methods as per Notice of the European Community no. 207/2014.

Parameters to fill in the average temperature package fiche (47/55)

Magis PRO 4 V2

Parameter	Colder zones	Average zones	Hotter zones
	■	■	■
"I"	96	127	149
"II"	*	*	*
"III"	6,68	5,35	5,35
"IV"	2,61	2,09	2,09

Magis PRO 6 V2

Parameter	Colder zones	Average zones	Hotter zones
	■	■	■
"I"	93	129	150
"II"	*	*	*
"III"	5,35	4,45	4,45
"IV"	2,09	1,74	1,74

Magis PRO 9 V2

Parameter	Colder zones	Average zones	Hotter zones
	■	■	■
"I"	93	127	154
"II"	*	*	*
"III"	3,82	3,34	3,34
"IV"	1,49	1,31	1,31

* to be determined according to Regulation 811/2013 and transient calculation methods as per Notice of the European Community no. 207/2014.

INSTALLER

USER

MAINTENANCE TECHNICIAN

TECHNICAL DATA

Parameters to fill in the low temperature package fiche (30/35)

Magis PRO 4 V2 paired with Super Trio

Parameter	Colder zones	Average zones	Hotter zones
	■	■	■
"I"	138	180	233
"II"	*	*	*
"III"	6,68	5,35	5,35
"IV"	2,61	2,09	2,09

Magis PRO 6 V2 paired with Super Trio

Parameter	Colder zones	Average zones	Hotter zones
	■	■	■
"I"	140	180	234
"II"	*	*	*
"III"	5,35	4,45	4,45
"IV"	2,09	1,74	1,74

Magis PRO 9 V2 paired with Super Trio

Parameter	Colder zones	Average zones	Hotter zones
	■	■	■
"I"	138	175	241
"II"	*	*	*
"III"	3,34	2,97	2,97
"IV"	1,31	1,16	1,16

* to be determined according to Regulation 811/2013 and transient calculation methods as per Notice of the European Community no. 207/2014.

Parameters to fill in the average temperature package fiche (47/55)

Magis PRO 4 V2 paired with Super Trio

Parameter	Colder zones	Average zones	Hotter zones
	■	■	■
"I"	96	127	149
"II"	*	*	*
"III"	6,68	5,35	5,35
"IV"	2,61	2,09	2,09

Magis PRO 6 V2 paired with Super Trio

Parameter	Colder zones	Average zones	Hotter zones
	■	■	■
"I"	93	129	150
"II"	*	*	*
"III"	5,35	4,45	4,45
"IV"	2,09	1,74	1,74

Magis PRO 9 V2 paired with Super Trio

Parameter	Colder zones	Average zones	Hotter zones
	■	■	■
"I"	93	127	154
"II"	*	*	*
"III"	3,82	3,34	3,34
"IV"	1,49	1,31	1,31

* to be determined according to Regulation 811/2013 and transient calculation methods as per Notice of the European Community no. 207/2014.

INSTALLER

USER

MAINTENANCE TECHNICIAN

TECHNICAL DATA

Room central heating system package fiche.

Room central heating seasonal energy efficiency of the heat pump

%

Temperature control
From temperature
control board

Class I = 1 %, Class II = 2 %,
Class III = 1.5 %, Class IV = 2 %,
Class V = 3 %, Class VI = 4 %,
Class VII = 3.5 %, Class VIII = 5 %

+ %

Supplementary boiler
From boiler board

Seasonal central heating energy efficiency of the room (%)

(- _____) x _____ = - %

Solar contribution

From the board of the solar device

Dimensions of the manifold (in m²)

Volume of the tank (in m³)

Efficiency of the manifold (in %)

Classification of the tank
A* = 0.95, A = 0.91,
B = 0.86, C = 0.83,
D-G = 0.81

(_____ x + _____ x) x 0.45 x (/ 100) x = + %

Room central heating seasonal energy efficiency of the assemble in average climate conditions

%

Room central heating seasonal energy efficiency class of the assemble in average climate conditions

<input type="checkbox"/>	<input type="checkbox"/>	<input type="checkbox"/>	<input type="checkbox"/>	<input type="checkbox"/>	<input type="checkbox"/>	<input type="checkbox"/>	<input type="checkbox"/>	<input type="checkbox"/>	<input type="checkbox"/>
G	F	E	D	C	B	A	A⁺	A⁺⁺	A⁺⁺⁺
< 30 %	≥ 30 %	≥ 34 %	≥ 36 %	≥ 75 %	≥ 82 %	≥ 90 %	≥ 98 %	≥ 125 %	≥ 150 %

Room central heating seasonal energy efficiency in colder and hotter climate conditions

Colder: - _____ = %

Hotter: + _____ = %

The energy efficiency of the set of products indicated in this sheet may not reflect the actual energy efficiency after installation since such efficiency is affected by additional factors, such as the heat loss in the distribution system and the size of the products compared to the size and features of the building.





This instruction booklet is made of ecological paper.

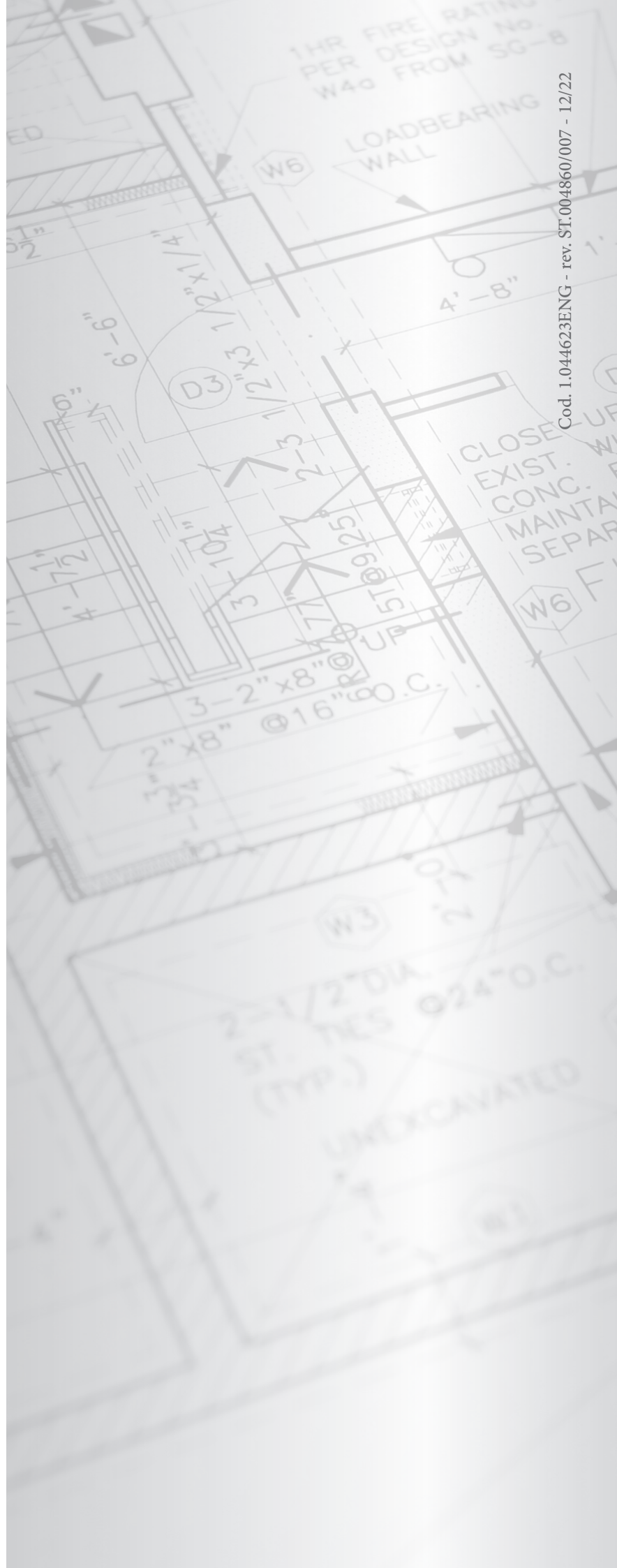

Cod. 1.044623ENG - rev. ST.004860/007 - 12/22

immergas.com

Immergas S.p.A.
42041 Brescello (RE) - Italy
Tel. 0522.689011
Fax 0522.680617



IMMERCAS
IMMERCAS SPA - ITALY
CERTIFIED COMPANY
UNI EN ISO 9001:2015

Design, manufacture and post-sale assistance of gas boilers, gas water heaters and related accessories