

MANUAL  
USER'S

**Instructions and  
recommendations** **IE**  
Installer  
User  
Maintenance technician

\*1.043500ENG\*



**IMMERGAS**

## AVIO ECO 24

The European regulation 813/2013 provides that this boiler can be installed only to replace similar equipment connected to existing branched multiple flues.





## INDEX

Dear Customer.....	4	2.8	Restore central heating system pressure.....	25
General recommendations.....	4	2.9	Draining the system.....	25
Safety symbols used.....	5	2.10	Draining the domestic hot water circuit.....	25
Personal protective equipment.....	5	2.11	Storage tank draining.....	25
		2.12	Antifreeze protection.....	25
1 Boiler installation.....	6	2.13	Cleaning the case.....	25
1.1 Installation recommendations.....	6	2.14	Decommissioning.....	25
1.2 Main dimensions.....	9			
1.3 Minimum installation distances.....	9	3	Instructions for maintenance and initial check.....	26
1.4 Antifreeze protection.....	10	3.1	General warnings.....	26
1.5 Boiler connection unit.....	11	3.2	Initial check.....	26
1.6 Gas connection.....	11	3.3	Yearly appliance check and maintenance.....	27
1.7 Hydraulic connection.....	12	3.4	Hydraulic Diagram.....	28
1.8 Electrical connection.....	12	3.5	Wiring diagram.....	29
1.9 Remote controls and room chrono-thermostats (Optional).....	13	3.6	Troubleshooting.....	30
1.10 External probe (Optional).....	14	3.7	Possible adjustments of the gas valve.....	30
1.11 Ventilation of the rooms.....	14	3.8	Information Menu.....	31
1.12 Evacuation of combustion products: smoke ducts and branched multiple flues.....	14	3.9	Programming the P.C.B.....	32
1.13 Flue exhaust control device.....	15	3.10	Automatic soft ignition function.....	34
1.14 System filling.....	15	3.11	“Chimney sweep” function.....	34
1.15 Gas system start-up.....	15	3.12	Pump anti-block function.....	34
1.16 Boiler start-up (Ignition).....	15	3.13	three-way anti-block system.....	34
1.17 Domestic hot water storage tank unit.....	15	3.14	Radiators antifreeze function.....	34
1.18 Circulation pump.....	16	3.15	Periodical P.C.B. self-check.....	34
1.19 Boiler components.....	18	3.16	Casing removal.....	35
1.20 Kits available on request.....	18			
		4	Technical data.....	37
2 Instructions for use and maintenance.....	19	4.1	Variable heat output.....	37
2.1 General warnings.....	19	4.2	Combustion parameters.....	37
2.2 Cleaning and maintenance.....	21	4.3	Technical data table.....	38
2.3 Ventilation of the rooms.....	21	4.4	Key for Data nameplate.....	39
2.4 Control panel.....	21	4.5	Technical parameters for combination boilers (in compliance with Regulation 813/2013).....	40
2.5 Using the boiler.....	22	4.6	Product fiche (in compliance with Regulation 811/2013).....	41
2.6 Fault and anomaly signals.....	23	4.7	Parameters for filling in the package fiche.....	42
2.7 Boiler shutdown.....	25			

Dear Customer,

*Congratulations for having chosen a top-quality Immergas product, able to assure well-being and safety for a long period of time. As an Immergas customer you can also count on a qualified after-sales service, prepared and updated to guarantee constant efficiency of your boiler. Read the following pages carefully: you will be able to draw useful tips on the correct use of the device, compliance of which will confirm your satisfaction with the Immergas product.*

*For any assistance and scheduled maintenance please contact Authorised Immergas After-Sales centres: they have original spare parts and are specifically trained by the manufacturer.*

## GENERAL RECOMMENDATIONS

This book contains important information for the:

**Installer** (section 1);

**User** (section 2);

**Maintenance Technician** (section 3).

- The user must carefully read the instructions in the specific section (section 2).
- The user must limit operations on the appliance only to those explicitly allowed in the specific section.
- The appliance must be installed by qualified and professionally trained personnel.
- The instruction booklet is an integral and essential part of the product and must be given to the new user in the case of transfer or succession of ownership.
- It must be stored with care and consulted carefully, as all of the warnings provide important safety indications for installation, use and maintenance stages.
- In compliance with the legislation in force, the systems must be designed by qualified professionals, within the dimensional limits established by the Law. Installation and maintenance must be performed in compliance with the regulations in force, according to the manufacturer's instructions and by professionally qualified staff, meaning staff with specific technical skills in the plant sector, as provided for by Law.
- Improper installation or assembly of the Immergas device and/or components, accessories, kits and devices can cause unexpected problems for people, animals and objects. Read the instructions provided with the product carefully to ensure proper installation.
- This instructions manual provides technical information for installing Immergas products. As for the other issues related to the installation of products (e.g. safety at the workplace, environmental protection, accident prevention), it is necessary to comply with the provisions of the standards in force and the principles of good practice.
- All Immergas products are protected with suitable transport packaging.
- The material must be stored in a dry place protected from the weather.
- Damaged products must not be installed.
- Maintenance must be carried out by skilled technical staff. For example, the Authorised Immergas Service Centre that represents a guarantee of qualifications and professionalism.
- The device must only be destined for the use for which it has been expressly declared. Any other use will be considered improper and therefore potentially dangerous.
- If errors occur during installation, operation and maintenance, due to non-compliance with technical laws in force, standards or instructions contained in this booklet (or however supplied by the manufacturer), the manufacturer is excluded from any contractual and extra-contractual liability for any damages and the device warranty is invalidated.



The company **IMMERGAS S.p.A.**, with registered office in via Cisa Ligure 95 42041 Brescello (RE), declares that the design, manufacturing and after-sales assistance processes comply with the requirements of standard **UNI EN ISO 9001:2015**.

For further details on the product CE marking, request a copy of the Declaration of Conformity from the manufacturer, specifying the appliance model and the language of the country.

The manufacturer declines all liability due to printing or transcription errors, reserving the right to make any modifications to its technical and commercial documents without forewarning.

## SAFETY SYMBOLS USED.



### GENERIC HAZARD

Strictly follow all of the indications next to the pictogram. Failure to follow the indications can generate hazard situations resulting in possible harm to the health of the operator and user in general.



### ELECTRICAL HAZARD

Strictly follow all of the indications next to the pictogram. The symbol indicates the appliance's electrical components or, in this manual, identifies actions that can cause an electrical hazard.



### MOVING PARTS

The symbol indicates the appliance's moving components that can cause hazards.



### HOT SURFACES

The symbol indicates the appliance's very hot components that can cause burns.



### SHARP SURFACES

The symbol indicates the appliance's components or parts that can cause cuts if touched.



### EARTH TERMINAL CONNECTION

The symbol identifies the appliance's earth terminal connection point.

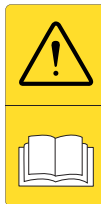

### READ AND UNDERSTAND THE INSTRUCTIONS

Read and understand the appliance's instructions before performing any operation, carefully following the indications provided.



### INFORMATION

Indicates useful tips or additional information.



### RECOVERABLE OR RECYCLABLE MATERIAL



The user must not dispose of the appliance at the end of its service life as municipal waste, but send it to appropriate collection centres.

## PERSONAL PROTECTIVE EQUIPMENT.



### SAFETY GLOVES



### SAFETY GOGGLES



### SAFETY FOOTWEAR

# 1 BOILER INSTALLATION.

## 1.1 INSTALLATION RECOMMENDATIONS.

### ATTENTION:

operators who install and service the appliance must wear the personal protective equipment required by applicable law.

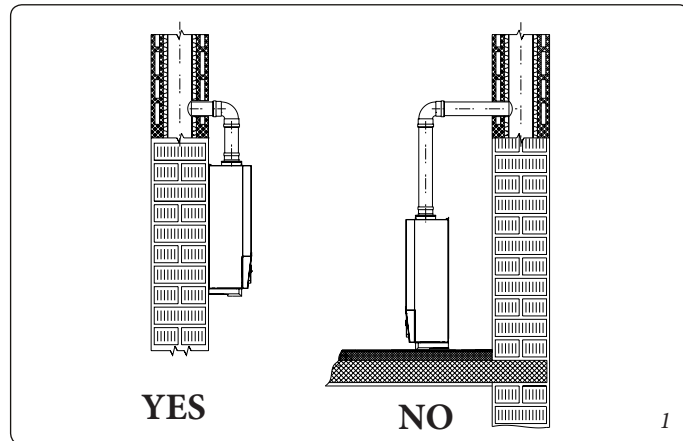

The Avio Eco 24 kW boiler has been designed for wall mounted installation only, for central heating and production of domestic hot water for domestic use and similar purposes.



The place of installation of the appliance and relative Immergas accessories must have suitable features (technical and structural), such as to allow for (always in safe, efficient and comfortable conditions):

- installation (according to the provisions of technical legislation and technical regulations);
- maintenance operations (including scheduled, periodic, routine and special maintenance);
- removal (to outdoors in the place for loading and transporting the appliances and components) as well as the eventual replacement of those with appliances and/or equivalent components.

The wall surface must be smooth, without any protrusions or recesses enabling access to the rear part. They are not designed to be installed on plinths or floors (Fig. 1).

**N.B.:** classification of the appliance is B11<sub>BS</sub>.

Only professionally enabled companies are authorised to install Immergas gas appliances.

Installation must be carried out according to regulation standards, current legislation and in compliance with local technical regulations and the required technical procedures.

### ATTENTION:

It is not permitted to install boilers that are removed and decommissioned from other systems. The manufacturer declines all liability for damages caused by boilers removed from other systems or for any non-conformities of such equipment.



### ATTENTION:

check the environmental operating conditions of all parts relevant to installation, referring to the values shown in the technical data table in this booklet.



### ATTENTION:

if installing a kit or servicing the appliance, always empty the system's domestic hot water circuit first so as not to compromise the appliance's electrical safety (Par. 2.9 and 2.10).



Before installing the appliance, ensure that it is delivered in perfect condition; if in doubt, contact the supplier immediately. Packing materials (staples, nails, plastic bags, polystyrene foam, etc.) constitute a hazard and must be kept out of the reach of children.



If the appliance is installed inside or between cabinets, ensure sufficient space for normal servicing; therefore it is advisable to leave clearance of at least 3 cm between the boiler casing and the vertical sides of the cabinet. Leave adequate space above the boiler for possible water and flue removal connections (Fig. 3).

It is just as important that the intake grids and exhaust terminals are not obstructed.

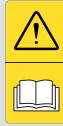

Keep all flammable objects away from the appliance (paper, rags, plastic, polystyrene, etc.).

The minimum distance for exhaust pipes from flammable materials must be at least 25 cm.

Do not put household appliances under the boiler as they could be damaged if the safety valve trips or if the hydraulic fittings leak. Otherwise, the manufacturer cannot be held liable for any damage to the household appliances.

For the aforementioned reasons, we recommend not placing furnishings, furniture, etc. under the boiler.

In the event of malfunctions, faults or incorrect operation, turn the appliance off immediately and contact an authorised company (e.g. the Immergas Technical Assistance centre, which has specifically trained staff and original spare parts). Do not attempt to modify or repair the appliance alone.

Any modification to the appliance that is not explicitly indicated in this section of the booklet is forbidden.

### Installation Standards:



- **these boilers cannot be installed in bedrooms, studio flats and bathrooms. They also cannot be installed in rooms with wood (or solid fuel) burning heat generators and in communicating rooms.**
- **Installation in places with a fire risk is prohibited (for example: underground car parks, garages), potentially dangerous places, gas appliances and relative flue ducts.**

- **Installation is prohibited on the vertical projection of the cooking surface.**



- **Installation is forbidden in places/rooms that constitute public areas of apartment buildings, internal stairways or other escape routes (e.g. floor landings, entrance halls, etc.).**

- **Installation is also forbidden in places/rooms that constitute public areas of apartment buildings such as cellars, entrance halls, attics, lofts, etc., unless otherwise provided for by local regulations in force.**

- **These boilers are not suitable for installation on walls made of combustible material.**

**N.B.: wall mounting of the boiler must guarantee stable and efficient support for the boiler.** The plugs (standard supply) are only to be used to fix the boiler to the wall; they only ensure adequate support if inserted correctly (according to technical standards) in walls made of solid or semi-hollow brick or block. In the case of walls made from hollow brick or block, partitions with limited static properties, or in any case walls other than those indicated, a static test must be carried out to ensure adequate support.



These boilers are used to heat water to below boiling temperature in atmospheric pressure. They must be connected to a central heating system and domestic hot water circuit suited to their performance and capacity.



**“Anti-Legionella” heat treatment of the Immergas storage tank (function enabled when the system is provided with temperature control).**

During this phase, the temperature of the water inside the tank exceeds 60°C with the subsequent risk of burns. Keep this domestic hot water treatment under control (and inform the users) to prevent unforeseeable damage to people, animals, things. If required install a thermostatic valve on the domestic hot water outlet to prevent scalding.

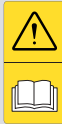

**Risk of damage due to corrosion caused by unsuitable combustion air and environment.**

Spray, solvents, chlorine-based detergents, paints, glue, ammonium compounds, powders and similar cause product and flue duct corrosion.

- Check that combustion air power supply is free from chlorine, sulphur, powders, etc.
- Make sure that no chemical substances are stored in the place of installation.
- If you want to install the product in beauty salons, paint workshops, carpenter's shop, cleaning companies or similar, choose a separate installation area that ensures combustion air supply that is free from chemical substances.
- Make sure the combustion air is not fed from chimneys that were used with gas boilers or other heating devices. In fact, these may cause an accumulation of soot in the chimney.

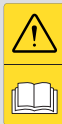
**Risk of material damage after using sprays and liquids to search for leaks**

Leak sprays and liquids clog the reference hole PR (Part. 7 Fig. 17) of the gas valve, damaging it irreparably.

During installation and maintenance, do not use spray or liquids in the upper area of the gas valve (side referring to the electric connections)

**ATTENTION:**

- **Type B open chamber boilers must not be installed in places where commercial, artisan or industrial activities take place, which use products that may develop volatile vapours or substances (e.g. acid vapours, glues, paints, solvents, combustibles, etc.), as well as dusts (e.g. dust deriving from the working of wood, coal fines, cement, etc.), which may be damaging for the components of the appliance and jeopardise functioning.**
- **The installation rooms must be permanently ventilated, in compliance with the local regulations in force (at least 6 cm<sup>2</sup> for every kW of installed heat input, except in the event of any increases needed for electro-mechanical vacuum cleaners or other devices that could put the installation room under vacuum).**

**ATTENTION:**

- **they must also be installed in an environment in which the temperature cannot fall below 0°C. They must not be exposed to atmospheric agents.**

**ATTENTION:**

- **Failure to comply with the above implies personal responsibility and invalidates the warranty.**



### 1.2 MAIN DIMENSIONS.

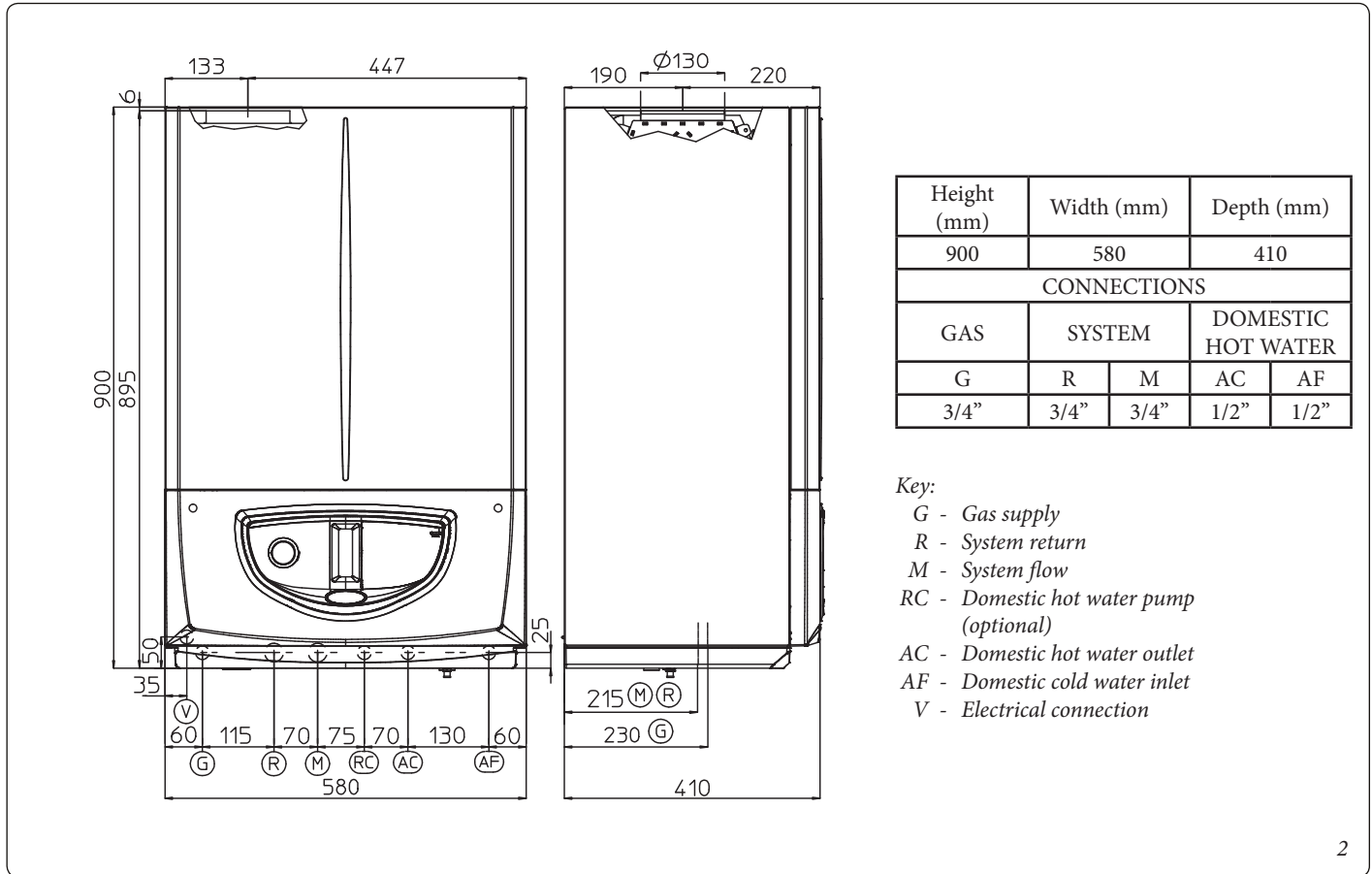

INSTALLER

USER

### 1.3 MINIMUM INSTALLATION DISTANCES.

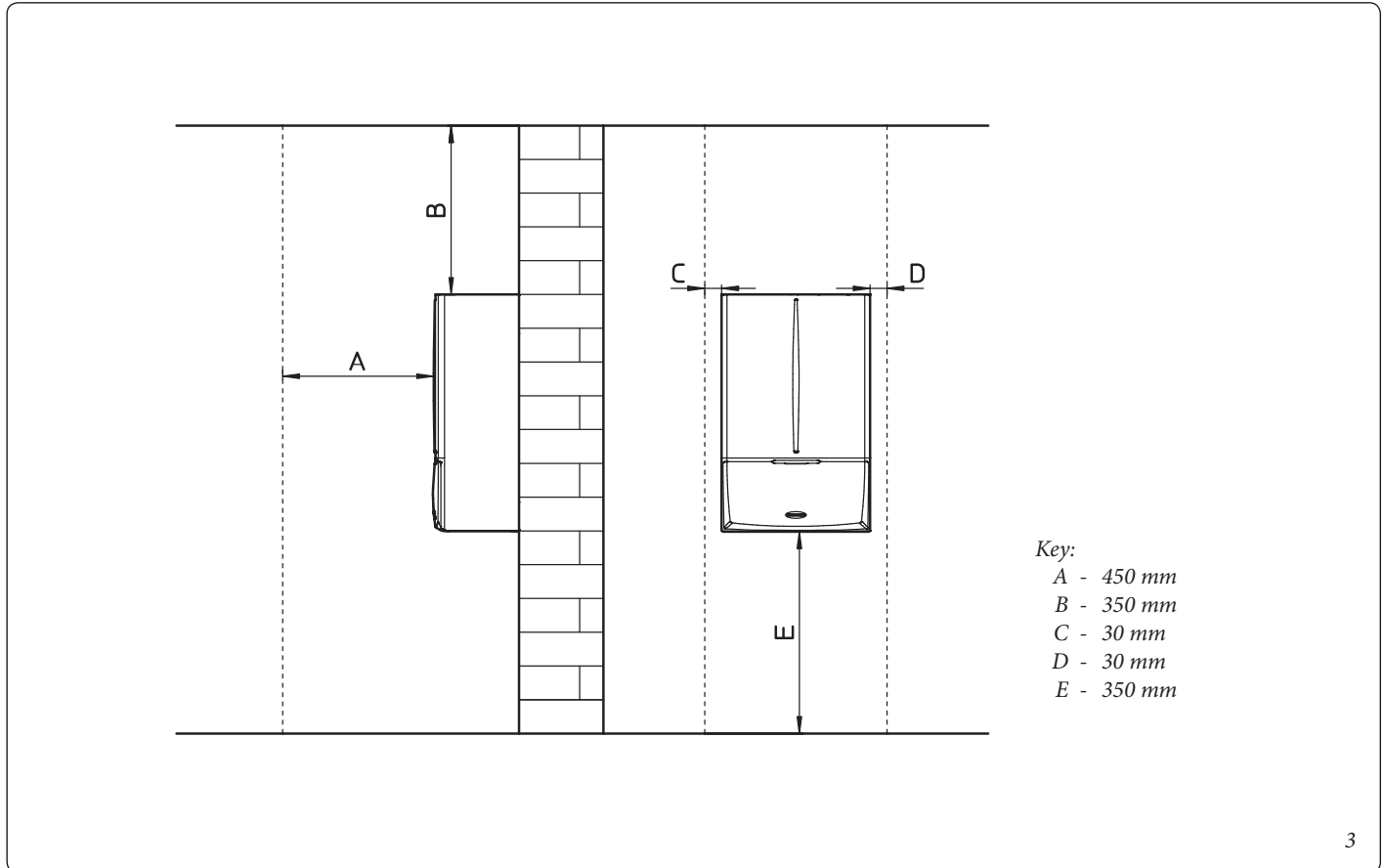

MAINTENANCE TECHNICIAN

#### 1.4 ANTIFREEZE PROTECTION.

**Minimum temperature 0°C.** The boiler comes standard with an antifreeze function that activates the pump and burner when the system water temperature in the boiler falls below 4°C.

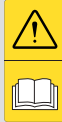

*In these conditions the boiler is protected against freezing to an ambient temperature of 0°C.*

**To prevent the risk of freezing follow the instructions below:**

- protect the central heating circuit from freezing by inserting a good-quality antifreeze liquid into this circuit, which is specially suited for central heating systems and which is manufacturer guaranteed not to cause damage to the heat exchanger or other components of the boiler. The antifreeze liquid must not be harmful to one's health. The instructions of the manufacturer of this liquid must be strictly followed regarding the necessary percentage with respect to the minimum temperature at which the system must be kept.

**N.B.:** the excessive use of glycol could jeopardise the proper functioning of the appliance.

An aqueous solution must be made with potential pollution class of water 2 (EN 1717:2002).

The materials used for the central heating circuit of Immergas boilers resist ethylene and propylene glycol based antifreeze liquids (if the mixtures are prepared perfectly).

For life and possible disposal, follow the supplier's instructions.

Boiler antifreeze protection is thus only ensured if:

- the boiler is correctly connected to gas and electricity power supply circuits;
- the boiler is powered constantly;
- the boiler is not in "off" mode;
- the boiler is not in anomaly conditions (Paragraph 2.6);

The warranty does not cover damage due to interruption of the electrical power supply and failure to comply with that stated on the previous page.

**N.B.:** if the boiler is installed in places where the temperature falls below 0°C the domestic hot water and central heating attachment pipes must be insulated.

**N.B.:** the antifreeze systems described in this chapter are only to protect the boiler. The presence of these functions and devices does not exclude the possibility of parts of the system or domestic hot water circuit outside the boiler from freezing.

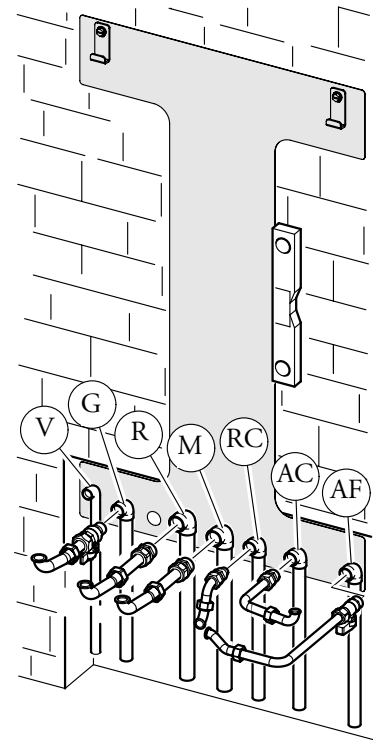

*The kit includes:*

- N°2 - 3/4" telescopic fittings (R-M)
- N°1 - 1/2" telescopic fitting (U)
- N°1 - 1/2" gas cock (G)
- N°1 - 1/2" ball valve (E)
- N°3 - Ø18 copper bends
- N°2 - Ø14 copper bends
- N°2 - adjustable expansion bolts
- N°2 - boiler support hooks
- Gaskets and seal O-Ring

*Key:*

- G - 1/2" gas supply
- R - 3/4" system return
- M - 3/4" System flow
- RC - 1/2" domestic hot water recirculation
- AC - 1/2" domestic hot water outlet
- AF - 1/2" domestic cold water inlet
- V - Electrical connection 230V-50Hz

### 1.5 BOILER CONNECTION UNIT.

The connection unit consisting of all the necessary parts to perform the hydraulic and gas system connections of the appliance comes as a standard supply. Perform the connections respecting the layout of (Fig. 4) based on the type of installation to be made.

### 1.6 GAS CONNECTION.

Our boilers are designed to operate with methane gas (G20). Supply pipes must be the same as or larger than the boiler fitting.

#### ATTENTION:

**Before connecting the gas line, carefully clean inside all the fuel feed system pipes to remove any residue that could impair boiler efficiency. Also make sure the gas corresponds to that for which the boiler is prepared (see boiler data nameplate). It is also important to check the dynamic pressure of the mains (methane) used to supply the boiler, which must comply with EN 437 and its attachment, as insufficient levels may reduce generator output and cause discomfort to the user.**



**According to local regulations in force, make sure that a gas cock is installed upstream of each connection between the appliance and the gas system. This cock, if supplied by the appliance's manufacturer, can be directly connected to the appliance (i.e. downstream from the pipes connecting the system to the appliance), according to the manufacturer's instructions.**



The Immergas connection unit, which is a standard supply, also includes the gas cock, whose installation instructions are provided in the kit.

In any case, make sure the gas cock is connected properly.

The gas supply pipe must be suitably dimensioned according to current regulations in order to guarantee correct gas flow rate to the burner even in conditions of maximum generator output and to guarantee appliance efficiency (technical specifications). The coupling system must conform to standards in force (EN 1775).

#### ATTENTION:

**the appliance is designed to operate with fuel gas free from impurities; otherwise it is advisable to fit special filters upstream of the appliance to restore the purity of the fuel.**

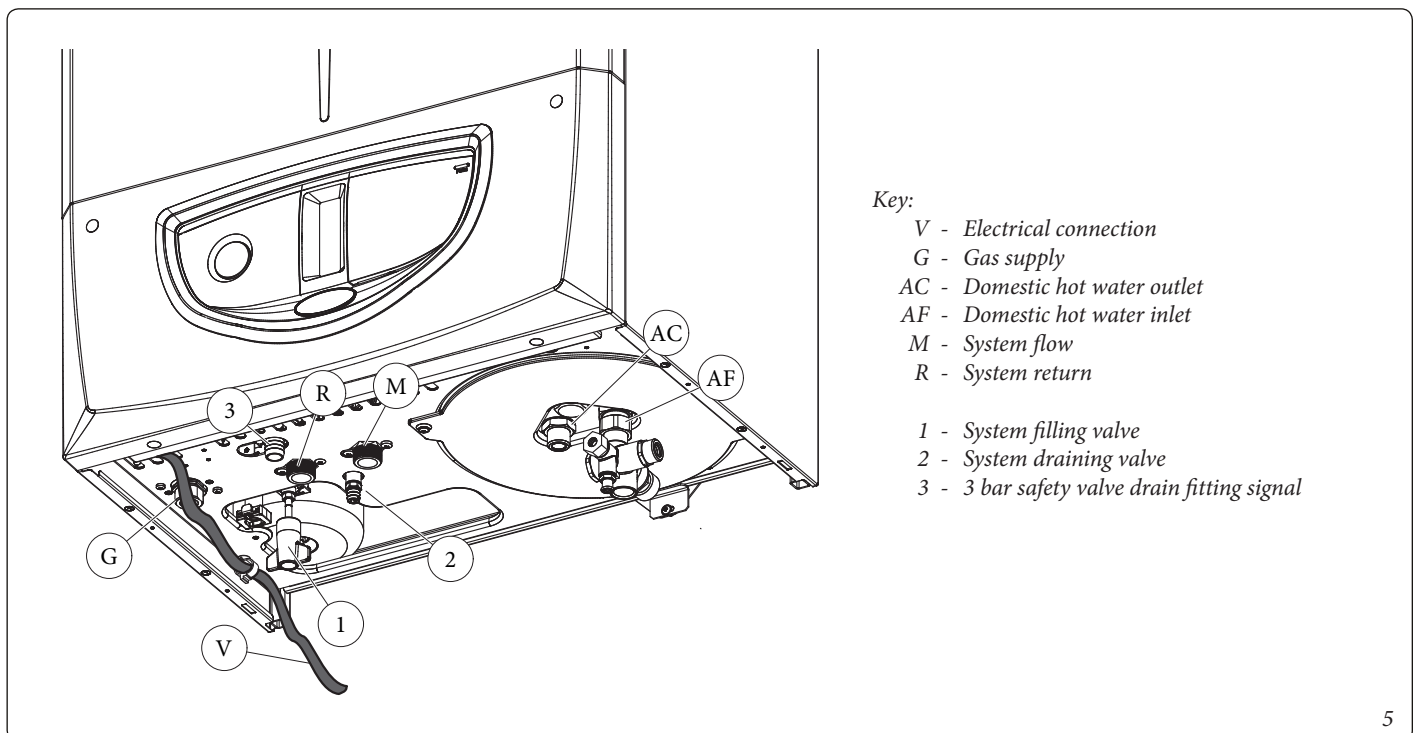

Key:

V - Electrical connection

G - Gas supply

AC - Domestic hot water outlet

AF - Domestic hot water inlet

M - System flow

R - System return

1 - System filling valve

2 - System draining valve

3 - 3 bar safety valve drain fitting signal

## 1.7 HYDRAULIC CONNECTION.

In order not to void the warranty of the primary heat exchanger before making the boiler connections, carefully clean the heating system (pipes, radiators, etc.) with special pickling or de-scaling products to remove any deposits that could compromise correct boiler operation.



A treatment of the heating and water system water is required, in compliance with the technical standards in force, in order to protect the system and the appliance from deposits (e.g. scale), slurry or other hazardous deposits. In order not to void the heat exchanger warranty, you are required to comply with what has been prescribed in Par. 1.14.

Hydraulic connections must be made in a rational way using the couplings on the boiler template. The boiler safety valve outlet must be connected to a draining funnel. Otherwise, the boiler's manufacturer declines any responsibility in case of flooding if the drain valve cuts in.

### ATTENTION:

**the manufacturer declines all liability in the event of damage caused by the installation of an automatic filling system.**



In order to meet the system requirements established by EN 1717 in terms of pollution of drinking water, we recommend installing the IMMERGAS anti-backflow kit to be used upstream of the cold water inlet connection of the boiler. We also recommend using a category 1, 2 or 3 heat transfer fluid (ex: water + glycol) in the boiler's primary circuit (C.H. circuit), as defined in standard EN 1717.

To preserve the duration of appliance efficiency features, in the presence of water whose features can lead to the deposit of lime scale, installation of the "polyphosphate dispenser" kit is recommended.



## 1.8 ELECTRICAL CONNECTION.

The appliance has an IPX5D protection degree; electrical safety of the appliance is achieved only when it is connected properly to an efficient earthing system, as specified by current safety standards.

### ATTENTION:

**the manufacturer declines any responsibility for damage or physical injury caused by failure to connect the boiler to an efficient earthing system or failure to comply with the IEC reference standards.**



Also ensure that the electrical installation corresponds to maximum absorbed power specifications as shown on the boiler data nameplate. The boilers are supplied complete with a "Y" type power cable without plug.

### ATTENTION:

**The power supply cable must be connected to a 230V  $\pm$ 10% / 50Hz mains supply respecting L-N polarity and earth connection; this network must also have a multi-pole circuit breaker with class III overvoltage category in compliance with installation regulations.**



To protect from possible dispersions of DC voltage, it is necessary to provide a type A differential safety device.

If the power cable is damaged, contact a qualified company (e.g. the Immergas Authorised After-Sales Technical Assistance Service) for its replacement to avoid a hazard.

The power cable must be laid as shown (Fig. 5).

If the network fuse on the connection terminal block needs replacing, this must also be done by qualified personnel: use a 3.15 A fast fuse.

For the main power supply to the appliance, never use adapters, multiple sockets or extension leads.

## 1.9 REMOTE CONTROLS AND ROOM CHRONO-THERMOSTATS (OPTIONAL).

The boiler is prepared for the application of room chrono-thermostats or remote controls, which are available as optional kits (Fig. 6).

All Immergas chrono-thermostats are connected with 2 wires only. Carefully read the user and assembly instructions contained in the accessory kit.

### ATTENTION:

**disconnect power to the appliance before any electrical connection.**



#### • On/Off Immergas digital chrono-thermostat.

The chrono-thermostat allows:

- set two room temperature value: one for day (comfort temperature) and one for night (reduced temperature);
- set a weekly programme with four daily switch on and switch off times;
- selecting the required function mode from the various possible alternatives:
  - manual mode (with adjustable temperature).
  - automatic mode (with set programme).
  - forced automatic mode (momentarily changing the temperature of the automatic programme).

The chrono-thermostat is powered by two 1.5V LR 6 type alkaline batteries;

#### • Comando Amico Remoto Remote Control Device <sup>V2</sup> (CAR<sup>V2</sup>) with climate chrono-thermostat function.

In addition to the functions described in the previous point, the CAR<sup>V2</sup> panel enables the user to control all the important information regarding operation of the appliance and the heating system with the opportunity to easily intervene on the previously set parameters, without having to go to where the appliance is installed. The panel is provided with self-diagnosis to display any boiler functioning anomalies. The climate chrono-thermostat incorporated into the remote panel enables the system flow temperature to be adjusted to the actual needs of the room being heated, in order to obtain the desired room temperature with extreme precision and therefore with evident saving in running costs. The CAR<sup>V2</sup> is fed directly by the boiler by means of the same 2 wires used for the transmission of data between the boiler and device.

**Comando Amico Remoto Remote Control <sup>V2</sup> or On/Off chrono-thermostat electrical connections (Optional).** *The operations described below must be performed after having removed the voltage from the appliance.* Any thermostat or On/Off environment chrono-thermostat must be connected to clamps 40 and 41 eliminating jumper X40 (Fig. 16). Make sure that the On/Off thermostat contact is of the “clean” type, i.e. independent of the mains voltage, otherwise the P.C.B. would be damaged. Any Comando Amico Remoto remote control<sup>V2</sup> must be connected to terminals 44 and 41, eliminating jumper X40 on the P.C.B. (Fig. 16). The boiler can only be connected to one remote control.

If the Comando Amico Remoto remote control <sup>V2</sup> or any other On/Off chrono-thermostat is used arrange two separate lines in compliance with current regulations regarding electrical systems. No boiler pipes must ever be used to earth the electric system or telephone lines. Ensure elimination of this risk before making the boiler electrical connections.



INSTALLER

USER

MAINTENANCE TECHNICIAN

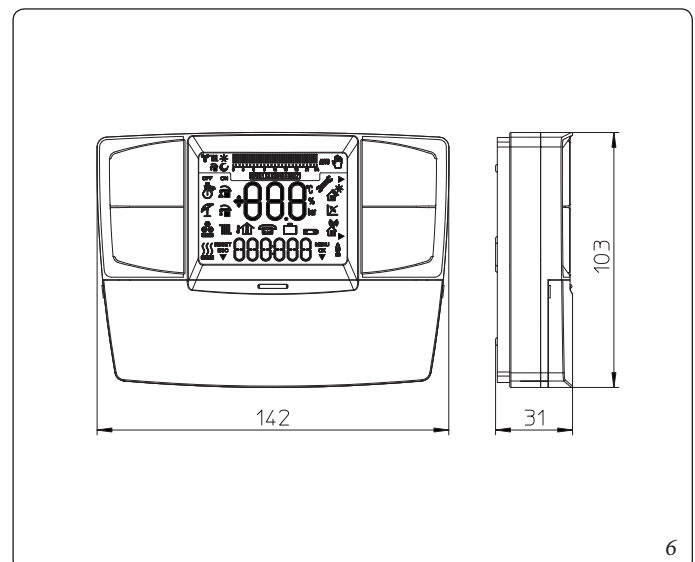

**1.10 EXTERNAL PROBE (OPTIONAL).**

The boiler is designed for the application of the external temperature probe (Fig. 7), which is available as an optional kit. Refer to the relative instruction sheet for positioning of the external probe. The probe can be connected directly to the boiler electrical system and allows the max. system flow temperature to be automatically decreased when the external temperature increases, in order to adjust the heat supplied to the system according to the change in external temperature. The external probe always operates when connected, regardless of the presence or type of room chrono-thermostat used and can work in combination with Immergas chrono-thermostats. The correlation between system flow temperature and external temperature is determined by the position of the central heating selector switch on the boiler control panel (or on the CAR<sup>v2</sup> control panel if connected to the boiler) according to the curves shown in the diagram (Fig. 8). The electric connection of the external probe must be made on clamps 38 and 39 on the terminal board in the boiler control panel (Fig. 16).

**1.11 VENTILATION OF THE ROOMS.**

In the room in which the boiler is installed it is necessary that at least as much air flows as that requested for by normal combustion of the gas and ventilation of the room. Natural air flow must take place directly through:

- permanent openings in the walls of the room to be ventilated that lead towards the outside;
- ventilation pipes, individual or branched type.

The air used for ventilation must be withdrawn directly from outside, in an area away from sources of pollution. Natural air flow is also allowed indirectly by air intake from adjoining rooms. For further information relative to ventilation of the rooms, follow the provisions of the laws in force.

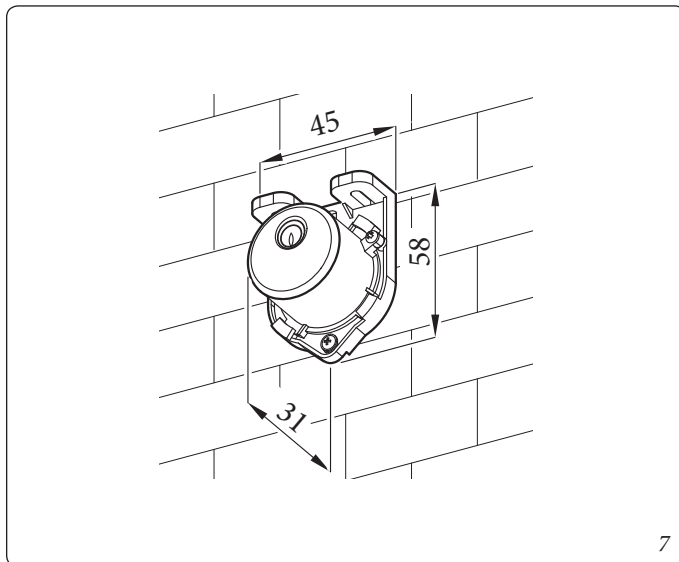

7

**Evacuation of foul air.**

In the rooms where the gas appliances are installed it may also be necessary, as well as the intake of combustion agent air, to evacuate foul air, with consequent intake of a further equal amount of clean air. This must be realised respecting the provisions of the technical regulations in force.



**1.12 EVACUATION OF COMBUSTION PRODUCTS: SMOKE DUCTS AND BRANCHED MULTIPLE FLUES.**

The European regulation 813/2013 provides that this boiler can be installed only to replace similar equipment connected to existing branched multiple flues.

**Connection to branched multiple flues.**

Fitting the appliances to a branched multiple flues takes place by means of flue ducts.

In the event of fittings with pre-existing flues, these must be in safe and efficient status and perfectly clean because the detachment of any waste from the walls during functioning, could block the passage of flue gases, thus causing extremely dangerous situations for the user.

The flue ducts must be connected to the flue in the same room in which the appliance is installed or, at most, in the adjoining room and:

- must comply with the regulations in force;
- must comply with EN 1856-2;
- must have a diameter that is not less than that of the device's outlet throughout its length (in this case D = 130 mm).

**EXTERNAL PROBE**  
Correction law of the flow temperature depending on the external temperature and user adjustment of the central heating temperature.

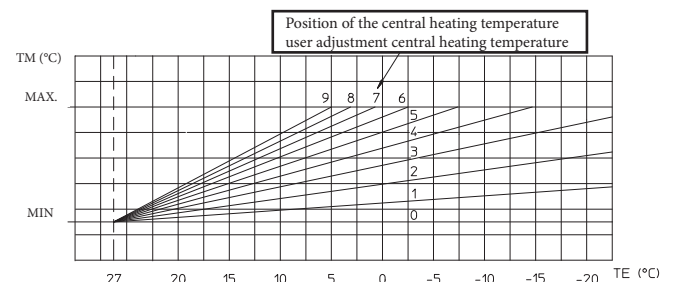

8

### 1.13 FLUE EXHAUST CONTROL DEVICE.

**Important:** it is prohibited to put the flue exhaust control device out of order voluntarily. Every piece of this device must be replaced using original spare parts if they have deteriorated. In the case of repeated interventions of the flue exhaust control device, check the fumes exhaust flue and the ventilation of the room in which the boiler is located.

**N.B.:** for the boiler to function correctly, the pipe the boiler is connected to is to have a minimum vacuum equivalent to the fan assisted of 1 meter of vertical pipe with a diameter of 130 mm.

### 1.14 SYSTEM FILLING.

Once the boiler is connected, proceed with system filling via the filling cock (Part. 9 Fig. 12). Filling is performed at low speed to ensure release of air bubbles in the water via the boiler and central heating system vents.

The boiler has a built-in automatic vent valve on the pump. Check if the cap is loose. Then open the radiator vent valves.

Close radiator vent valves when only water escapes from them. Close the filling valve when the boiler pressure gauge indicates approx. 1.2 bar.

**N.B.:** during these operations, enable the automatic vent functions on the boiler.

### 1.15 GAS SYSTEM START-UP.

To start up the system, refer to the technical standards in force.

### 1.16 BOILER START-UP (IGNITION).

To commission the boiler (the operations listed below must only be performed by qualified personnel and in the presence of staff only):

- check that the internal system is properly sealed according to the specifications set forth by regulations in force;
- ensure that the type of gas used corresponds to boiler settings;
- check connection to a 230V-50Hz power mains, correct L-N polarity and earthing connection;
- check that there are external factors that may cause the formation of fuel pockets;
- switch the boiler on and ensure correct ignition;
- make sure that the gas flow rate and relevant pressure values comply with those given in the manual (Par. 4.1);
- ensure that the safety device is engaged in the event of gas supply failure and check activation time;
- check the intervention of the main switch located upstream from the boiler and in the boiler;
- check that the intake/exhaust terminals (if fitted) are not blocked;

Should even just one of these checks have a negative outcome, the system must not be commissioned.

### 1.17 DOMESTIC HOT WATER STORAGE TANK UNIT.

The Avio Eco 24 storage tank is the accumulation type with a capacity of 45 litres. It contains a large coiled stainless steel heat exchanger pipe, which allows to notably reduce hot water production times. These storage tank units constructed with stainless steel casing and bottoms, guarantee long duration through time. The assembly concepts and welding (T.I.G.) are implemented to the minimum detail to ensure maximum reliability.

The lower inspection flange ensures practical control of the storage tank unit and the coiled heat exchanger pipe and easy internal cleaning.

The flange cover is provided with domestic hot water connection fittings (cold inlet and hot outlet) and a Magnesium anode holder cap including the device, which is a standard supply to protect the inner part of the storage tank from possible corrosion.

**N.B.:** every year, a qualified company (e.g. Authorised After-sales Service), must check the efficiency of the storage tank unit Magnesium Anode. The storage tank unit is prepared for introduction of the domestic hot water pump fitting.

### 1.18 CIRCULATION PUMP.

The boiler is supplied with circulator fitted with speed regulator. These settings are suitable for most systems.

In fact, the pump is equipped with electronic control to set advanced functions. For proper operation one must select the most suitable type of operation for the system and select a speed in the available range, with a focus on energy savings.

**By-pass Regulation (Part. 19 Fig. 12).** The boiler leaves the factory with the bypass open.

If necessary, the by-pass can be regulated to system requirements from minimum (by-pass closed) to maximum (by-pass open). Adjust using a flat-head screwdriver. Turning clockwise opens the bypass and anticlockwise closes it.

**Display of operation status.** During normal operation the status LED (2) is on green, the four yellow LEDs (3) indicate circulator absorption according to the following table:

Circulating pump LED	Absorption															
<table style="margin-left: auto; margin-right: auto;"> <tr> <td>G</td><td>Y</td><td>Y</td><td>Y</td><td>Y</td> </tr> <tr> <td>●</td><td>●</td><td>○</td><td>○</td><td>○</td> </tr> <tr> <td>On</td><td>On</td><td>Off</td><td>Off</td><td>Off</td> </tr> </table>	G	Y	Y	Y	Y	●	●	○	○	○	On	On	Off	Off	Off	0 ÷ 25 %
G	Y	Y	Y	Y												
●	●	○	○	○												
On	On	Off	Off	Off												
<table style="margin-left: auto; margin-right: auto;"> <tr> <td>G</td><td>Y</td><td>Y</td><td>Y</td><td>Y</td> </tr> <tr> <td>●</td><td>●</td><td>●</td><td>○</td><td>○</td> </tr> <tr> <td>On</td><td>On</td><td>On</td><td>Off</td><td>Off</td> </tr> </table>	G	Y	Y	Y	Y	●	●	●	○	○	On	On	On	Off	Off	25 ÷ 50 %
G	Y	Y	Y	Y												
●	●	●	○	○												
On	On	On	Off	Off												
<table style="margin-left: auto; margin-right: auto;"> <tr> <td>G</td><td>Y</td><td>Y</td><td>Y</td><td>Y</td> </tr> <tr> <td>●</td><td>●</td><td>●</td><td>●</td><td>○</td> </tr> <tr> <td>On</td><td>On</td><td>On</td><td>On</td><td>Off</td> </tr> </table>	G	Y	Y	Y	Y	●	●	●	●	○	On	On	On	On	Off	50 ÷ 75 %
G	Y	Y	Y	Y												
●	●	●	●	○												
On	On	On	On	Off												
<table style="margin-left: auto; margin-right: auto;"> <tr> <td>G</td><td>Y</td><td>Y</td><td>Y</td><td>Y</td> </tr> <tr> <td>●</td><td>●</td><td>●</td><td>●</td><td>●</td> </tr> <tr> <td>On</td><td>On</td><td>On</td><td>On</td><td>On</td> </tr> </table>	G	Y	Y	Y	Y	●	●	●	●	●	On	On	On	On	On	75 ÷ 100 %
G	Y	Y	Y	Y												
●	●	●	●	●												
On	On	On	On	On												

**Selection of operating mode.** To see the current operation mode it is sufficient to press button (1) once.

To change operation mode press the button for between 2 to 10 seconds until the current configuration flashing, each time the button is pressed all possible functions are scrolled cyclically. After a few seconds without doing any operation the circulator memorises the selected mode and goes back to operation display.

**Attention:** The circulator has various built-in operation modes, however the constant curve operation mode must be selected according to the following table.

Circulating pump LED	Description															
<table style="margin-left: auto; margin-right: auto;"> <tr> <td>G</td><td>Y</td><td>Y</td><td>Y</td><td>Y</td> </tr> <tr> <td>●</td><td>●</td><td>●</td><td>○</td><td>○</td> </tr> <tr> <td>On</td><td>On</td><td>On</td><td>Off</td><td>Off</td> </tr> </table>	G	Y	Y	Y	Y	●	●	●	○	○	On	On	On	Off	Off	Do not use
G	Y	Y	Y	Y												
●	●	●	○	○												
On	On	On	Off	Off												
<table style="margin-left: auto; margin-right: auto;"> <tr> <td>G</td><td>Y</td><td>Y</td><td>Y</td><td>Y</td> </tr> <tr> <td>●</td><td>●</td><td>●</td><td>●</td><td>○</td> </tr> <tr> <td>On</td><td>On</td><td>On</td><td>On</td><td>Off</td> </tr> </table>	G	Y	Y	Y	Y	●	●	●	●	○	On	On	On	On	Off	Constant curve speed 2
G	Y	Y	Y	Y												
●	●	●	●	○												
On	On	On	On	Off												
<table style="margin-left: auto; margin-right: auto;"> <tr> <td>G</td><td>Y</td><td>Y</td><td>Y</td><td>Y</td> </tr> <tr> <td>●</td><td>●</td><td>●</td><td>●</td><td>●</td> </tr> <tr> <td>On</td><td>On</td><td>On</td><td>On</td><td>On</td> </tr> </table>	G	Y	Y	Y	Y	●	●	●	●	●	On	On	On	On	On	Constant curve speed 3 <b>(default)</b>
G	Y	Y	Y	Y												
●	●	●	●	●												
On	On	On	On	On												
<table style="margin-left: auto; margin-right: auto;"> <tr> <td>G</td><td>Y</td><td>Y</td><td>Y</td><td>Y</td> </tr> <tr> <td>●</td><td>●</td><td>●</td><td>○</td><td>●</td> </tr> <tr> <td>On</td><td>On</td><td>On</td><td>Off</td><td>On</td> </tr> </table>	G	Y	Y	Y	Y	●	●	●	○	●	On	On	On	Off	On	Constant curve speed 4
G	Y	Y	Y	Y												
●	●	●	○	●												
On	On	On	Off	On												

Constant curve: the circulator operates maintaining constant speed.

**Selection button lock.** The button has a feature that locks its operation to prevent accidental modifications. To lock the control panel, it is necessary to press button (1) for more than 10 seconds (during which the current configuration flashes), the active lock is signalled by all LEDs of the control panel flashing. To unlock the button press again longer than 10 seconds.

**Real time diagnostics:** in the event of malfunction the LEDs provide information on the circulator operation status, see table (Fig. 10):

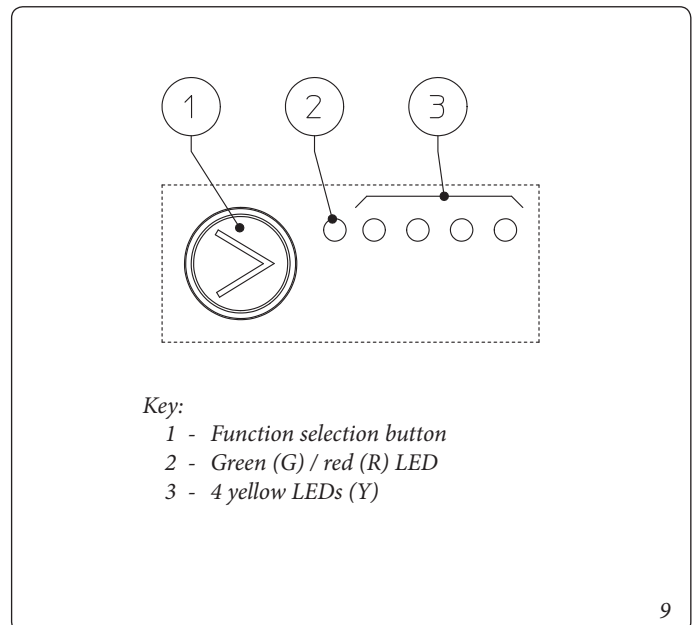



Circulating pump LED (first red LED)	Description	Diagnostics	Remedy
R    Y    Y    Y    Y ●   ○   ○   ○   ● On Off Off Off On	Circulator pump blocked	The circulator pump cannot restart automatically due to an anomaly	Wait for the circulator to make automatic release attempts or manually release the motor shaft acting on the screw in the centre of the head. If the anomaly persists replace the circulator.
R    Y    Y    Y    Y ●   ○   ○   ●   ○ On Off Off On Off	Abnormal situation (the circulator continues operating). low power supply voltage	Voltage off range	Check power supply
R    Y    Y    Y    Y ●   ○   ●   ○   ○ On Off On Off Off	Electrical fault (Circulator pump blocked)	The circulator is locked due to power supply too low or serious malfunction	Check the power supply, if the anomaly persists replace the circulator

Head available to the system.

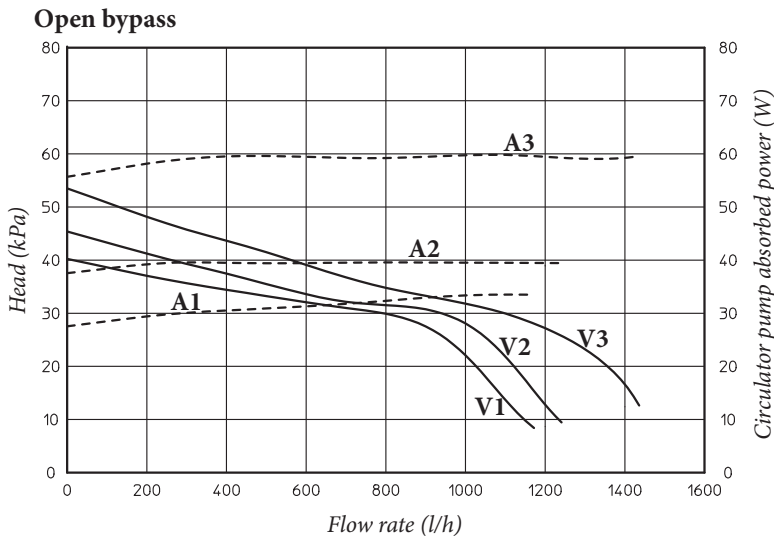

Key:

- V1 = Total head available to the system with pump at speed 2
- V2 = Total head available to the system with pump at speed 3
- V3 = Total head available to the system with pump at speed 4
- A1 = Power absorbed by the pump at speed 2
- A2 = Power absorbed by the pump at speed 3
- A3 = Power absorbed by the pump at speed 4

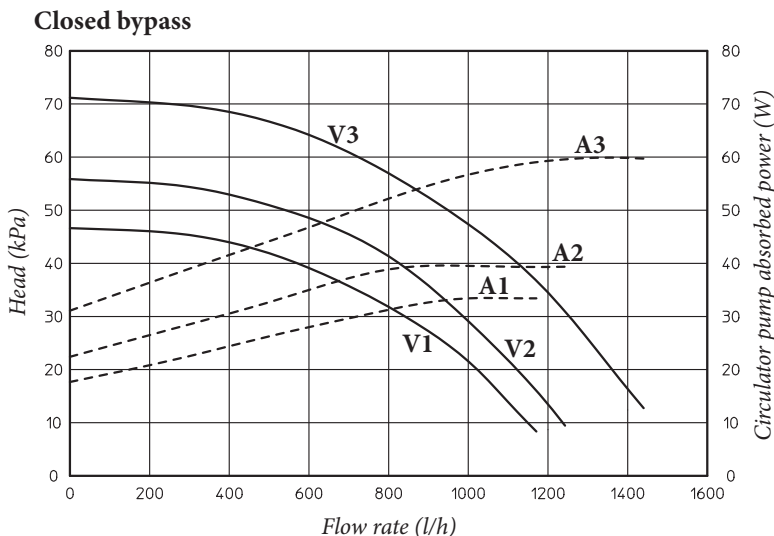

## 1.19 BOILER COMPONENTS.

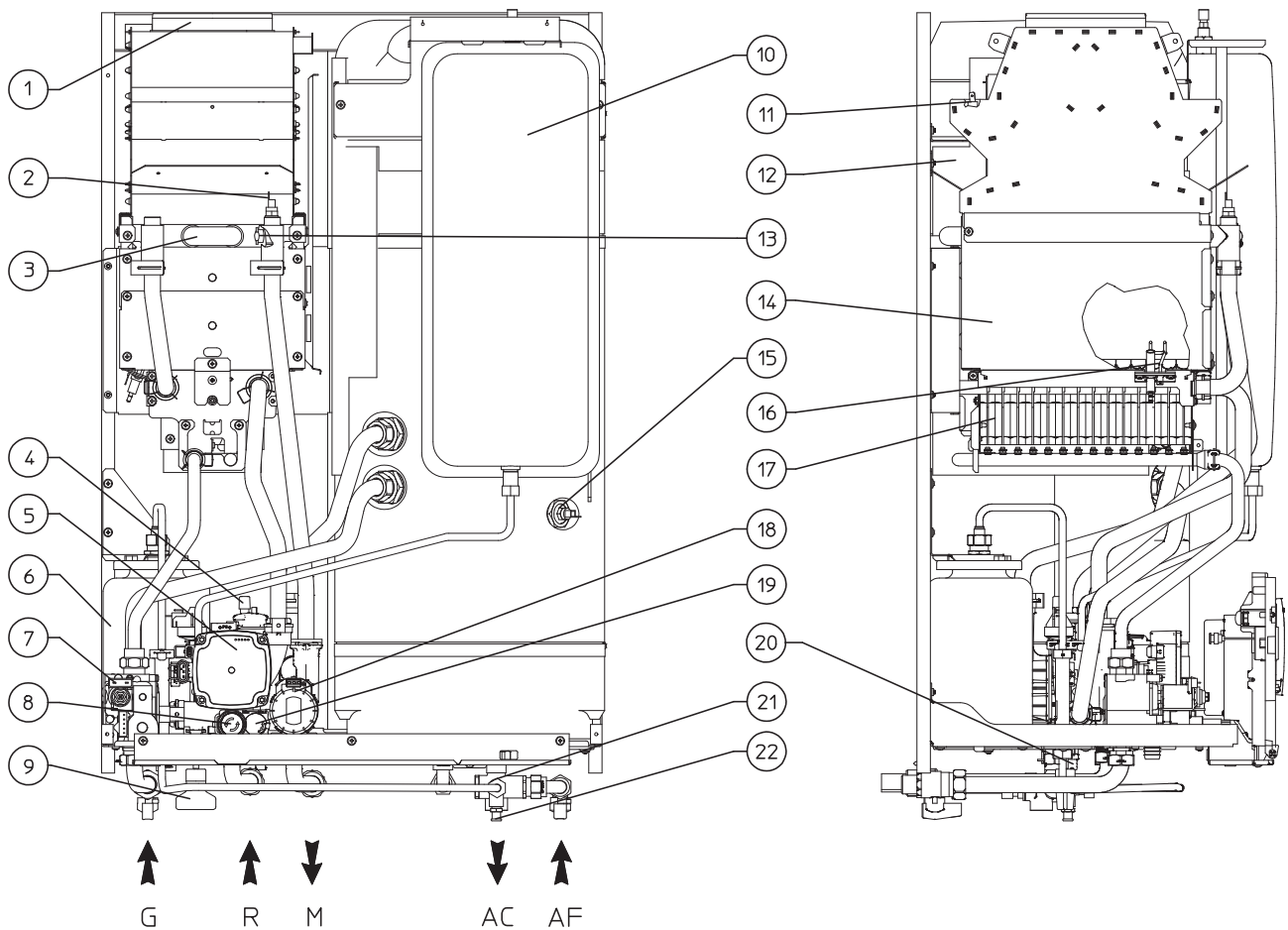

## Key:

- |   |                                       |
|---|---------------------------------------|
| 1 - Flue hood                           | 12 - Stainless steel storage tank     |
| 2 - Flow probe                          | 13 - Safety thermostat                |
| 3 - Primary heat exchanger              | 14 - Combustion chamber               |
| 4 - Air vent valve                      | 15 - D.H.W. probe                     |
| 5 - Boiler pump                         | 16 - Ignition and detection electrode |
| 6 - Domestic hot water expansion vessel | 17 - Burner                           |
| 7 - Gas valve                           | 18 - 3-way valve (motorised)          |
| 8 - 3 bar safety valve                  | 19 - Adjustable by-pass               |
| 9 - System filling valve                | 20 - System draining valve            |
| 10 - System expansion vessel            | 21 - 8 bar safety valve               |
| 11 - Flue safety thermostat             | 22 - Storage tank draining valve      |

12

## 1.20 KITS AVAILABLE ON REQUEST.

- System cut-off valves kit. The boiler is designed for installation of system interception cocks to be placed on flow and return pipes of the connection assembly. This kit is particularly useful for maintenance as it allows to drain just the boiler without having to empty the entire system.
- Polyphosphate dispenser kit. The polyphosphate dispenser reduces the formation of lime-scale and preserves the original heat exchange and domestic hot water production conditions. The boiler is prepared for application of the polyphosphate dispenser kit.

**N.B.:** this is a type of chemical conditioning treatment for domestic hot water, if provided for by current regulations.

- System zone control unit Kit. If the central heating system is to be divided into several zones (**max. three**), in order to interlock them with separate adjustments and to keep water flow rate high for each zone, Immergas supplies zone system kits by request.

The above-mentioned kits are supplied complete with instructions for assembly and use.

## 2 INSTRUCTIONS FOR USE AND MAINTENANCE.

### 2.1 GENERAL WARNINGS.

#### ATTENTION:

- Never expose the wall-mounted boiler to direct vapours from a cooking surface. 
- The device can be used by children at least 8 years old as well as by persons with reduced physical, sensory or mental capabilities, or lack of experience or required knowledge, provided that they are under surveillance, or after they have been instructed relating to the safe use and have understood the potential dangers. Children must not play with the appliance. Cleaning and maintenance destined to be performed by the user can not be carried out by unsupervised children.
- For safety purposes, check that the air intake/flue exhaust terminals (if fitted) are not blocked.
- If temporary shutdown of the boiler is required, proceed as follows:
  - a) drain the heating system if antifreeze is not used;
  - b) shut-off all electrical, water and gas supplies.
- In the case of work or maintenance to structures located in the vicinity of ducting or devices for flue extraction and relative accessories, switch off the appliance and on completion of operations ensure that a qualified technician checks efficiency of the ducting or other devices.
- Never clean the appliance or connected parts with easily flammable substances.
- Never leave containers or flammable substances in the same environment as the appliance.

- Do not open or tamper with the appliance. 
- Do not take apart or tamper with the intake and exhaust pipes.
- Only use the user interface devices listed in this section of the booklet.
- Do not climb on the appliance, do not use the appliance as a supporting surface.

#### ATTENTION:

The use of components involving use of electrical power requires some fundamental rules to be observed such as: 

- do not touch the appliance with wet or moist parts of the body; do not touch when barefoot;
- never pull electrical cables or leave the appliance exposed to atmospheric agents (rain, sunlight, etc.);
- the appliance power cable must not be replaced by the user;
- in the event of damage to the cable, switch off the appliance and contact exclusively qualified staff for replacement;
- if the appliance is not to be used for a certain period, disconnect the main power switch.

#### ATTENTION:

water at a temperature of more than 50 °C can cause serious burns. Always check the water temperature before any use. 

The temperatures indicated by the display have a tolerance of +/- 3°C due to environmental conditions that cannot be blamed on the boiler. 

**ATTENTION:**

if you smell gas in the building:



- close the gas meter interception device or the main interception device;
- if possible, close the gas interception cock on the product;
- if possible, open doors and windows wide and create an air current;
- do not use open flames (e.g. lighters, matches);
- do not smoke;
- do not use electrical switches, plugs, door bells, telephones or intercom devices in the building;
- call an authorised company (e.g. Authorised After-Sales Service).

**ATTENTION:**

if you smell burning or see smoke coming out of the appliance, switch it off, disconnect the power, close the main gas cock, open the windows and call an authorised company (e.g. Authorised After-Sales Service).

**ATTENTION:**

At the end of its service life, the appliance must not be disposed of like normal household waste nor abandoned in the environment, but must be removed by a professionally authorised company as required by current legislation. Contact the manufacturer for disposal instructions.



## 2.2 CLEANING AND MAINTENANCE.

To preserve the boiler's integrity and keep the safety features, performance and reliability, which distinguish it, unchanged over time, you must execute maintenance operations on a yearly basis in compliance with what is stated in the relative point at "annual check and maintenance of the appliance", in compliance with national, regional, or local standards in force.

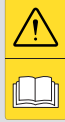

## 2.3 VENTILATION OF THE ROOMS.

In the room in which the boiler is installed it is necessary that at least as much air flows as that requested for by normal combustion of the gas and ventilation of the room. The provisions relative to ventilation, the flue ducts and multiple flues are stated in Par. 1.12 and 1.13. If in doubt regarding correct ventilation, contact an authorised company.

## 2.4 CONTROL PANEL.

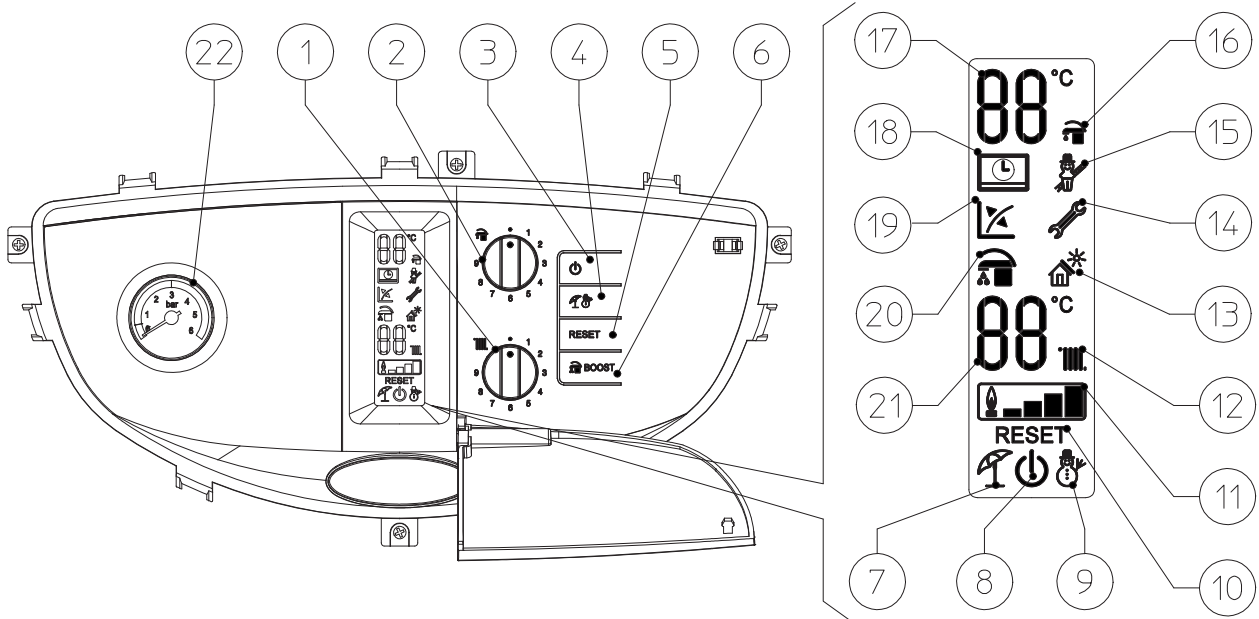

### Key:

- |   |  |  |
|---|--|--|
| 1 - Central heating temperature selector                      | 10 - Blocked boiler, it needs to be unblocked by pressing the "RESET" button | 16 - DHW production phase function active                        |
| 2 - Domestic hot water temperature selector                   | 11 - Flame presence symbol and relative output scale                         | 17 - Domestic hot water temperature set                          |
| 3 - On/Stand-by/Off Button                                    | 12 - Room central heating mode functioning active                            | 18 - Boiler connected to V2 remote control (optional)            |
| 4 - Summer/Winter Button                                      | 13 - Solar function active (Not used)  | 19 - Operation with external temperature probe active (optional) |
| 5 - Reset Button  | 14 - Anomaly present   | 20 - Booster function active                                     |
| 6 - Boost button (for activating / disabling D.H.W. priority) | 15 - Chimney sweep function in progress                                      | 21 - Central heating temperature set                             |
| 7 - Operation in summer mode                                  |  | 22 - Boiler manometer  |
| 8 - Boiler in Stand-by mode                                   |  |  |
| 9 - Operation in winter mode                                  |  |  |

## 2.5 USING THE BOILER.

Before ignition make sure the central heating system is filled with water and that the pressure gauge (22) indicates a pressure of 1 - 1.2 bar.

- Open the gas cock upstream from the boiler.
- Press the button (🔌) until the display switches on. At this point, the boiler goes to the state previous to switch-off (Off).
- If the boiler is on “Stand-by”, press (🔌) again to enable it, otherwise go to the next point.
- Then press the button (🌞🌙) in sequence and set the boiler in the summer (🌞) or winter (🌙) position.
- **Summer (🌞):** in this mode the boiler only works to produce DHW; the temperature is set via the selector (2) and the relative temperature is shown on the display via the indicator (17).

During a request for DHW the indicator (🚰) switches on. Upon ignition of the burner, the flame presence indicator (🔥📊) with relative power scale switches on and the indicator (17) shows the instant outlet temperature from the primary heat exchanger.

- **Winter (🌙):** in this mode the boiler works both for producing domestic hot water and for central heating. The temperature of the DHW is always regulated via the selector (2), the heating temperature is regulated via selector (1) and the relative temperature is shown on the display via the indicator (21).

During a request for CH the indicator (🔥📊) switches on. Upon ignition of the burner, the flame presence indicator (🔥📊) with relative power scale switches on and the indicator (21) shows the instant outlet temperature from the primary heat exchanger. In the central heating mode, if the temperature of the water contained in the system is sufficient to heat the radiators, the boiler can only function with the activation of the boiler pump (indicator 12 on).

From this moment the boiler functions automatically. With no demand for heat (central heating or domestic hot water production) the boiler goes to “standby” function, equivalent to the boiler being powered without presence of flame. Each time the burner ignites, the relative flame present symbol is displayed (🔥📊) with relative output scale.

- **Operation with Comando Amico Remoto remote control v2 (CAR<sup>v2</sup>) (Optional).** If the CAR<sup>v2</sup> is connected, the (📺) symbol will appear on the display. The boiler regulation parameters can be set via the CAR<sup>v2</sup> control panel and the “RESET” button remains active on the boiler control panel, along with (🔌) for switch-off (“off” mode only) and the display where the functioning state is shown.

### ATTENTION:

if the boiler is put into “off” mode, the “CON” connection error symbol will appear on the CAR<sup>v2</sup>. The CAR<sup>v2</sup> is however powered constantly so as not to lose memorised programs. ⚠️

When the water supplied by the solar system is at a temperature lower than that at which the boiler is set, the boiler switches on. At this point, the solar function symbol will stay on without flashing.

- **Booster function (🚰).** Press the Boost button (6; symbol 🚰) to enable a timer that forces the storage tank set point to minimum for the duration equivalent to “storage tank unabling timer”. After timing, the setpoint is reset. Pressing “🚰” again with the timer running, cancels it. When the timer is enabled, the display will show the change in setpoint.

### ATTENTION:

activation of this function in presence of water whose characteristics may cause the onset of limescale can cause premature clogging of the D.H.W. heat exchanger (see hydraulic connection). ⚠️

- **Operation with optional external probe (🌡️).** In the case of a system with optional external probe, the boiler flow temperature for room central heating is managed by the external probe depending on the external temperature measured (Par. 1.10). The flow temperature can be modified by selecting the functioning curve via selector (1), selecting a value from “0 to 9” (Fig. 13).

With external probe present, the relative symbol (🌡️) will appear on the display. In the central heating mode, if the temperature of the water contained in the system is sufficient to heat the radiators, the boiler can only function with the activation of the pump.

- **Standby mode.** Press button (3) until the (🔌) symbol appears. The boiler remains active from this moment and the antifreeze function, pump anti-block function and 3-way and signalling of any anomalies is guaranteed.

### ATTENTION:

in these conditions the boiler is considered still live. ⚡

- **“Off” mode.** By holding the button (🔌) down for 8 seconds, the display switches-off and the boiler is off completely. The safety functions are not guaranteed in this mode.

### ATTENTION:

in these conditions the boiler is considered still live. ⚡

- **Display functioning.** The display lights up during the use of the control panel or if the burner is ignited, after 15 seconds inactivity, the brightness drops until just the active symbols are displayed. The lighting mode can be varied via parameter P2 in the P.C.B. customisation menu.

## 2.6 FAULT AND ANOMALY SIGNALS.

In the event of an anomaly, it is signalled via the flashing indicator (  ) and flashing of the relative error code (21) according to the following table.

On any remote controls (CAR<sup>V2</sup>), the error code will be displayed using a numerical code preceded or followed by the letter E (e.g. CAR<sup>V2</sup>= Exx).

Error Code	Anomaly signalled	Cause	Boiler status / Solution
01	No ignition ignition	In the event of request of room central heating or domestic hot water production, the boiler does not switch on within the preset time. Upon appliance commissioning or after extended downtime, it may be necessary to eliminate the block.	Press the Reset button (1)
02	Thermostat safety (safety) overheating, flame control anomaly	During normal operation, if a fault causes excessive overheating internally, the boiler goes into overheating block.	Press the Reset button (1).
03	Flue safety thermostat block	During normal operation, if a fault causes excessive flue gas overheating, the boiler blocks	Press the Reset button (1)
04	Generic boiler P.C.B. anomaly	Safety thermostat fault (overheating) or flame control anomaly.	The boiler does not start (1).
05	Storage tank probe flow	The board detects an anomaly on the flow NTC probe.	The boiler does not start (1)
08	Maximum N° of resets	Number of allowed resets already performed.	The anomaly can be reset 5 times consecutively, after which the function is inhibited for at least one hour. One attempt is gained every hour for a maximum of 5 attempts. By switching the appliance on and off again, the 5 attempts are re-acquired.
10	Insufficient system pressure	Water pressure inside the central heating circuit that is sufficient to guarantee the correct operation of the boiler is not detected.	Check on the boiler pressure gauge that the system pressure is between 1÷1.2 bar and restore the correct pressure if necessary.
12	Storage tank probe anomaly	The board detects an anomaly on the storage tank probe.	The boiler cannot produce domestic hot water (1)
15	Configuration error	If the board detects an anomaly or incongruity on the electric wiring, the boiler will not start.	If normal conditions are restored the boiler restarts without having to be reset (1).
20	Parasite flame block	This occurs in the event of a leak on the detection circuit or anomaly in the flame control unit.	Press the Reset button (1)
24	Push button control panel anomaly	The board detects an anomaly on the pushbutton panel.	If normal conditions are restored the boiler restarts without having to be reset (1).
27	Circulation insufficient	This occurs if there is overheating in the boiler due to insufficient water circulating in the primary circuit; the causes can be: - low system circulation; check that no shut-off devices are closed on the heating circuit and that the system is free of air (deaerated); - circulating pump blocked; free the circulating pump.	Press the Reset button (1).
31	Loss of remote control communication	This occurs if an incompatible remote control is connected, or if communication between the boiler and the remote control is lost.	Disconnect and reconnect the power to the boiler. If the Remote Control is still not detected on re-starting, the boiler will switch to local operating mode, i.e. using the controls on the control panel. In this case the "Central Heating" (1) function cannot be activated.
37	Low power supply voltage	This occurs when the power supply voltage is lower than the allowed limits for the correct boiler operation.	If normal conditions are restored the boiler restarts without having to be reset (1)
38	Loss of flame signal	This occurs when the boiler is ignited correctly and the burner flame switches off unexpectedly; a new attempt at ignition is performed and if normal conditions are restored, the boiler does not have to be reset.	If normal conditions are restored the boiler restarts without having to be reset (1)

(1) If the shutdown or fault persists, contact an authorised company (e.g. Authorised Technical After-Sales Service)

Error Code	Anomaly signalled	Cause	Boiler status / Solution
43	<b>Block due to loss of continuous flame signal</b>	This occurs if the "Flame signal loss" error occurs 6 times consecutively in 8.5 minutes (38)".	Press the Reset button (1).
44	<b>Block for maximum time, partial gas valve opening</b>	This occurs if the gas valve remains open for longer than required for normal operation, without the boiler switching on.	Press the Reset button (1).

(1) If the shutdown or fault persists, contact an authorised company (e.g. Authorised Technical After-Sales Service)



## 2.7 BOILER SHUTDOWN.

Disconnect the main switch (9) by placing it on “” (LEDs 1 to 8 are off), disconnect the external omni-polar switch to the boiler and close the gas cock upstream of the appliance. Never leave the boiler switched on if left unused for prolonged periods.

## 2.8 RESTORE CENTRAL HEATING SYSTEM PRESSURE.

Periodically check the system water pressure. The boiler pressure gauge should read a value of between 1 and 1.2 bar.

*If pressure falls below 1 bar (with the circuit cold), restore normal pressure via the cock located at the bottom of the boiler (Part. 1 Fig. 5).*

**N.B.:** close the cock after the operation.

If pressure values reach around 3 bar the safety valve may be activated.

In this case, remove water from a radiator air vent valve until a pressure of 1 bar is achieved, or ask for assistance from professionally qualified personnel.

In the event of frequent pressure drops, contact qualified staff for assistance to eliminate the possible system leakage.

## 2.9 DRAINING THE SYSTEM.

To drain the boiler, use the special draining valve (Part. 20 Fig. 12). Before draining, ensure that the filling cock is closed.

### ATTENTION:

**if glycol was input in the system's circuit, make sure it is discharged into the waste water system, pursuant to regulation EN 1717**



## 2.10 DRAINING THE DOMESTIC HOT WATER CIRCUIT.

To do this, always close the domestic cold water inlet upstream of the appliance.

Open any domestic hot water tap to discharge the pressure from the circuit.

## 2.11 STORAGE TANK DRAINING.

To drain the storage tank, use the relevant storage tank draining valve (Fig. 14).

**N.B.:** before performing this operation, close the boiler cold water inlet valve and open any DHW system hot water valve in order to let air into the storage tank.

## 2.12 ANTIFREEZE PROTECTION.

The boiler comes standard with an antifreeze function that activates the pump and burner when the system water temperature in the boiler falls below 4°C.

The antifreeze function is guaranteed if the boiler is fully operative and not in “block” status, and is electrically powered with the Summer or Winter main switch. To avoid keeping the system switched on in case of a prolonged absence, the system must be drained completely or antifreeze substances must be added to the central heating system water. In both cases, the boiler's domestic hot water circuit must be drained. In systems that are drained frequently, filling must be carried out with suitably treated water to eliminate hardness that can cause lime-scale.

## 2.13 CLEANING THE CASE.

Use damp cloths and neutral detergent to clean the boiler casing. Never use abrasive or powder detergents.

## 2.14 DECOMMISSIONING.

In the event of permanent shutdown of the boiler, contact professional staff for the procedures and ensure that the electrical, water and gas supply lines are shut off and disconnected.

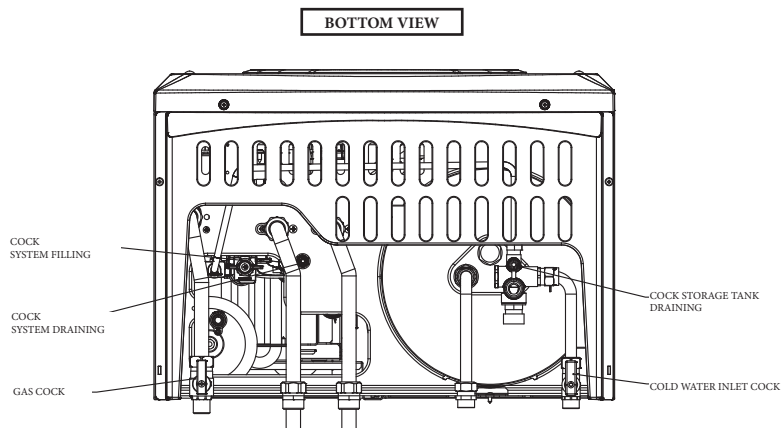

### 3 INSTRUCTIONS FOR MAINTENANCE AND INITIAL CHECK.

#### 3.1 GENERAL WARNINGS.

##### ATTENTION:

operators who install and service the appliance must wear the personal protective equipment (PPE) required by applicable law.



Note: the list of possible PPE is not complete as they are indicated by the employer.

##### ATTENTION:

before performing any maintenance operation, make sure:

- you have disconnected the power to the appliance;
- you have closed the gas cock;
- you have discharged the pressure from the system and domestic hot water circuit.



##### Risk of material damage after using sprays and liquids to search for leaks.

Leak sprays and liquids clog the reference hole PR (Part. 7 Fig. 17) of the gas valve, damaging it irreparably.

During installation and maintenance, do not use spray or liquids in the upper area of the gas valve (side referring to the electric connections)



##### Supply of spare parts.

The device's warranty shall be rendered null and void if unapproved or unsuitable parts are used for maintenance or repairs. These will also compromise the product's compliance, and the said product may no longer be valid and fail to meet the current regulations.

With regard to the above, only use Immergas original spare parts when replacing parts.



If additional documentation needs to be consulted for extraordinary maintenance, contact the Authorised Immergas After-Sales Service.



#### 3.2 INITIAL CHECK.

##### To commission the boiler:

- ensure that the type of gas used corresponds to boiler settings;
- check connection to a 230V-50Hz power mains, correct L-N polarity and the earthing connection;
- make sure the central heating system is filled with water and that the boiler manometer indicates a pressure of  $1 \div 1.2$  bar;
- make sure the air valve cap is open and that the system is well deaerated;
- switch the boiler on and ensure correct ignition;
- make sure the gas maximum and minimum flow rate and pressure values correspond to those given in the handbook (Par. 4.1);
- check activation of the safety device in the event of no gas, as well as the relative activation time;
- check activation of the main switch located upstream from the boiler;
- check the existing draught during normal functioning of the appliance, e.g. a draught gauge positioned at the exit of the appliance combustion products;
- check that there is no backflow of combustion products into the room, even during functioning of fans;
- ensure activation of all adjustment devices;
- seal the gas flow rate regulation devices (if settings are modified);
- ensure production of domestic hot water;
- ensure sealing efficiency of water circuits;
- check ventilation and/or aeration of the installation room where provided.

**Even if just one single safety check provides a negative result, do not commission the system.**



### 3.3 YEARLY APPLIANCE CHECK AND MAINTENANCE.

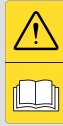

**The following checks and maintenance should be performed at least once a year to ensure operation, safety and efficiency of the appliance over time.**

- Clean the flue side of the heat exchanger.
- Clean the main burner.
- Check the correct positioning, integrity and cleanliness of the detection and ignition electrode; remove any oxide present.
- Visually check the draught-breaker/anti-wind device for deterioration or corrosion.
- Check correct lighting and operation.
- Ensure correct calibration of the burner in domestic water and central heating phases.
- Check correct operation of control and adjustment devices and in particular:
  - intervention of main electrical switch on boiler;
  - system control thermostat intervention;
  - domestic hot water control thermostat intervention.
- Check that the internal system is properly sealed according to specifications.
- Check the intervention of the device against no gas ionisation flame control. Intervention time must be less than 10 seconds.
- Visually check for water leaks or oxidation from/on connections.
- Visually check that the water safety drain valve is not blocked.
- Check, after discharging the system pressure and bringing it to zero (read on boiler pressure gauge), that the expansion vessel charge is at 1.0 bar.  
Check that the DHW expansion vessel load is at a pressure between 3 and 3.5 bar.
- Check that the system static pressure (with system cold and after refilling the system by means of the filling cock) is between 1 and 1.2 bar.
- Check visually that the safety and control devices have not been tampered with and/or shorted, in particular:
  - temperature safety thermostat;
  - flue exhaust control thermostat.
- Check the integrity of the storage tank Magnesium Anode.
- Check the condition and integrity of the electrical system and in particular:
  - electrical power cables must be inside the fairleads;
  - there must be no traces of blackening or burning.

In addition to yearly maintenance, one must also check the energy efficiency of the thermal system, with frequency and procedures that comply with the indications of the technical regulations in force.



INSTALLER

USER

MAINTENANCE TECHNICIAN

### 3.4 HYDRAULIC DIAGRAM.

INSTALLER

USER

MAINTENANCE TECHNICIAN

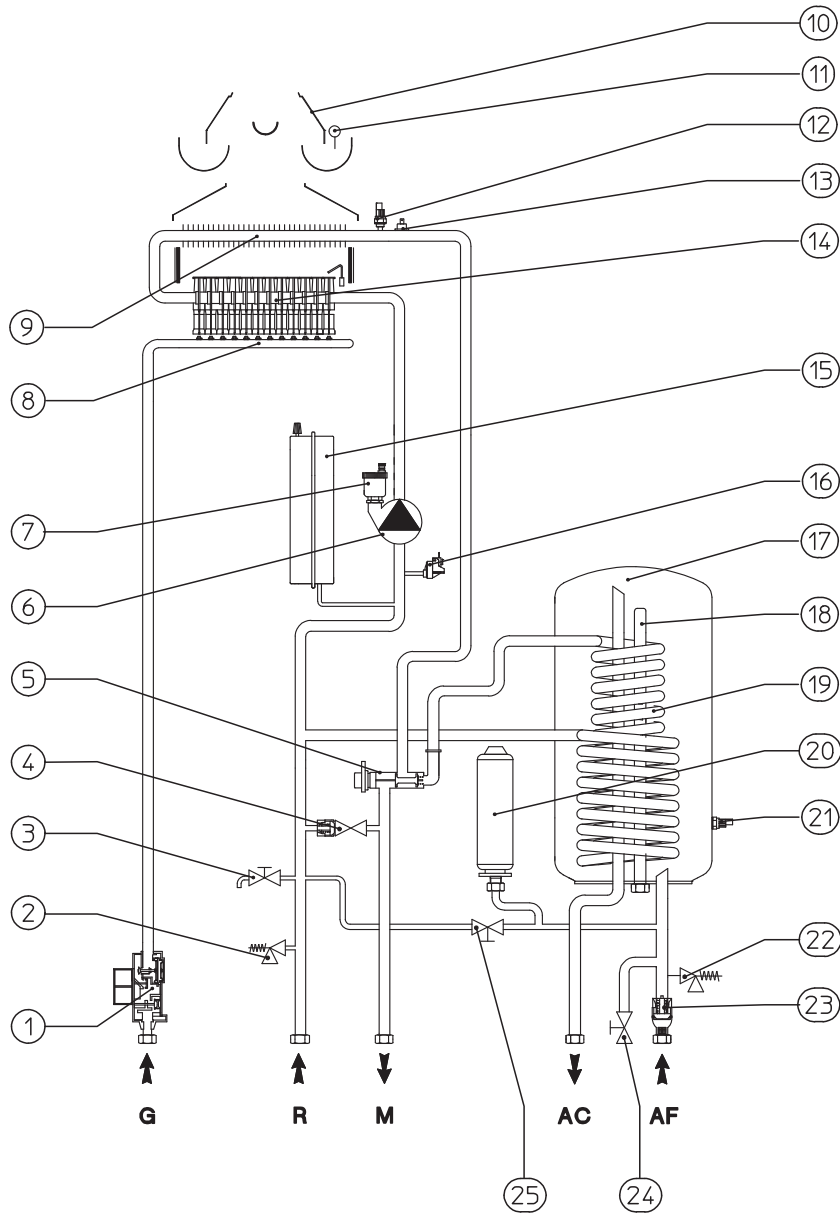

**Key:**

- 1 - Gas valve
- 2 - 3 bar safety valve
- 3 - System draining valve
- 4 - Bypass
- 5 - 3-way valve (motorised)
- 6 - Boiler pump
- 7 - Air vent valve
- 8 - Gas manifold
- 9 - Primary heat exchanger
- 10 - Flue hood
- 11 - Flue safety thermostat
- 12 - Flow probe
- 13 - Safety thermostat
- 14 - Burner
- 15 - System expansion vessel
- 16 - System pressure switch

- 17 - Stainless steel storage tank
- 18 - Magnesium anode
- 19 - Stainless steel coil for storage tank
- 20 - Domestic hot water expansion vessel
- 21 - D.H.W. probe
- 22 - 8 bar safety valve
- 23 - Cold water inlet non-return valve
- 24 - Storage tank draining valve
- 25 - System filling valve

- G - Gas supply
- AC - Domestic hot water outlet
- AF - Domestic cold water inlet
- R - System return
- M - System flow

### 3.5 WIRING DIAGRAM.

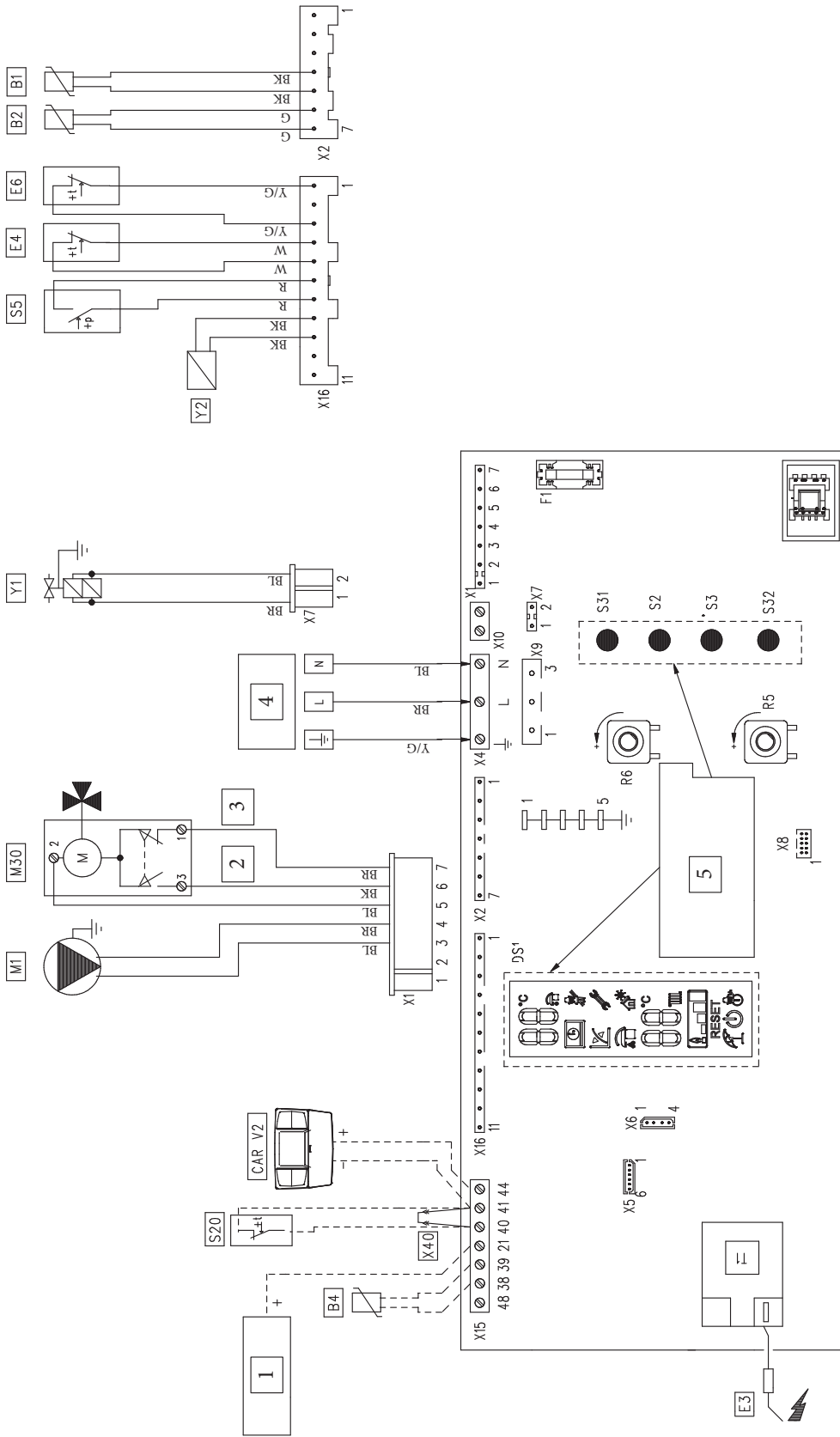

- Key:
- 1 - Zones control unit (optional)
  - 2 - DHW
  - 3 - Central heating
  - 4 - 230 Vac 50 Hz power supply
  - 5 - N.B.: the user interface is on the welding device side of the boiler board
  - B1 - Flow probe
  - B2 - D.H.W. probe
  - B4 - External probe (optional)
  - CAR V<sub>2</sub> - Comando Amico Remoto remote control Version 2 (optional)

- DS1 - Display
- E3 - Ignition and detection electrode
- E4 - Safety thermostat
- E6 - Flue safety thermostat
- F1 - Phase fuse
- M1 - Boiler pump
- M30 - Three-way valve
- R5 - DHW temperature trimmer
- R6 - C.H. temperature trimmer
- S2 - Selector switch functioning

- S3 - Reset button
- S5 - System pressure switch
- S20 - Room thermostat (optional)
- S31 - On/Stand-by/Off Button
- S32 - On Off storage tank unabling
- T1 - Ignition transformer
- X40 - Room thermostat jumper
- Y1 - Gas valve
- Y2 - Gas valve modulation coil

Colour code key:

- BK - Black
- BL - Blue
- BR - Brown
- G - Green
- GY - Grey
- R - Red
- W - White
- Y - Yellow
- Y/G - Yellow/Green

**MAINTENANCE TECHNICIAN**

**USER**

**INSTALLER**

Remote control: the boiler is set-up for the application of the Comando Amico Remoto remote control<sup>V2</sup> (CAR<sup>V2</sup>) which must be connected to clamps 41 and 44 of connector X15 on the P.C.B., observing polarity and eliminating jumper X40.

Room thermostat: the boiler is designed for the application of the Room Thermostat (S20). Connect it to clamps 40 – 41 eliminating jumper X40.

The connector X5 is used for the connection to the relay board.

The connector X6 is used for automatic inspection and for connection to the Virgilio palmtop during maintenance operations

The connector X8 is used for the connection of the Virgilio palmtop when updating the software.

### 3.6 TROUBLESHOOTING.

Maintenance operations must be carried out by an authorised company (e.g. Authorised After-Sales Technical Assistance Service).



- **Smell of gas.** Caused by leakage from gas circuit pipelines. Check sealing efficiency of gas intake circuit.
- **Irregular combustion (red or yellow flame).** When the burner is dirty or the boiler lamellar pack is blocked. Clean the burner or the lamellar pack.
- **Frequent trips of the temperature overheating safety device** It can depend on the lack of water in the boiler, little water circulation in the system or blocked pump. Check on the pressure gauge that the system pressure is within established limits. Check that the radiator valves are not closed and also the functionality of the pump.
- **The boiler produces condensate.** This can be caused by obstructions of the chimney or flues with height or section not proportioned to the boiler. It can also be determined by functioning at boiler temperatures that are excessively low. In this case, make the boiler run at higher temperatures.
- **Frequent trips of the flue safety thermostat.** This can be caused by obstructions in the fumes circuit. Check the flue. The flue may be obstructed or by height or section not suitable for the boiler. Ventilation may be insufficient (see room ventilation point).
- **Presence of air in the system.** Check opening of the special air vent valve cap (Fig. 12). Make sure the system pressure and expansion vessel pressure values are within the set limits; the pressure value for the expansion vessel must be 1.0 bar, and system pressure must be between 1 and 1.2 bar.
- **Ignition block and Chimney block.** See par. 2.6 and 1.8 (electrical connection).

### 3.7 POSSIBLE ADJUSTMENTS OF THE GAS VALVE.

- Adjustment of boiler nominal thermal heat output (Fig. 17).
  - Turn the domestic hot water temperature selector switch (Ref. 2 Fig. 13) in a maximum operation position;
  - open the domestic hot water cock in order to prevent modulation intervention;
  - adjust the nominal boiler power from the brass nut (3), keeping to the maximum pressure values provided in the tables (Par. 4.1) depending on the type of gas;
  - by turning in a clockwise direction the heating potential increases and in an anti-clockwise direction it decreases.
- Adjustment of minimum boiler heat output (Fig. 17).

**N.B.:** only proceed after having calibrated the nominal pressure.

Adjustment of the minimum thermal input is obtained by operating on the cross plastic screws (2) on the gas valve maintaining the brass nut blocked (3);

- disconnect the power supply to the modulating reel (just disconnect a faston); By turning the screw in a clockwise direction, the pressure increases, in an anti-clockwise direction it decreases. On completion of calibration, re-apply the power supply to the modulating coil. The minimum boiler power must not be adjusted to a pressure value below the levels stated in the tables (Par. 4.1) depending on the type of gas.

**N.B.:** to adjust the gas valve, remove the plastic cap (6); after adjusting, refit the cap.

Maintenance operations must be carried out by an authorised company (e.g. Authorised After-Sales Technical Assistance Service).

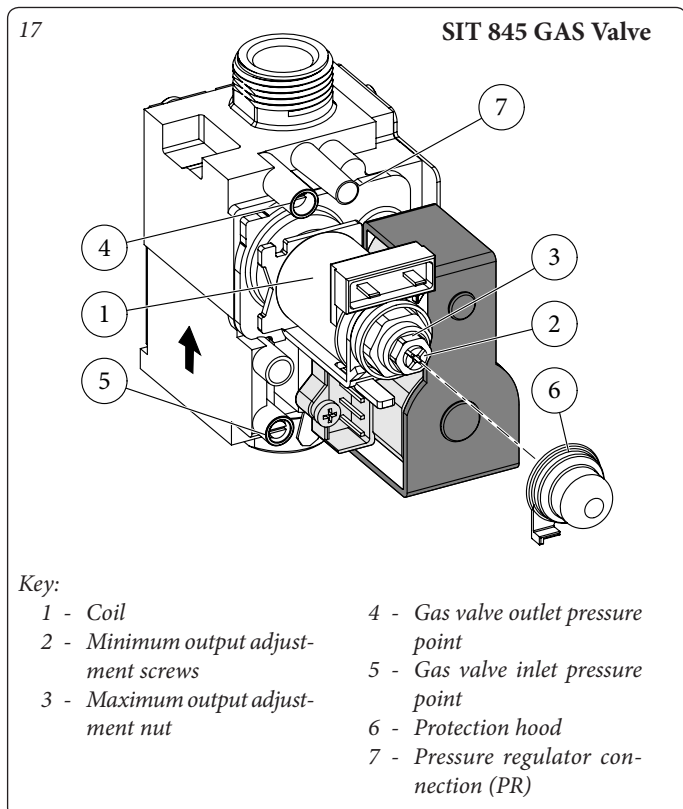

### 3.8 INFORMATION MENU.

Pressing the “” button for 4 seconds, the “Information menu” is activated, which allows to display some boiler functioning parameters.

Press the "RESET" button (4) to scroll the various parameters.

To exit the menu, press the “” button again for 4 seconds or wait for 120 seconds.

With the menu active on the indicator (17) the parameter n° is displayed while indicator (21) displays the parameter value.

Id Parameter (ref. 17)	Description
d1	Displays the flame signal (uA)
d2	Displays the primary heat exchanger output instant heating flow temperature
d3	Displays the instant output temperature from the DHW exchanger
d4	Displays the temperature set for the central heating set (if remote control is present)
d5	Displays the temperature set for the DHW set (if remote control is present)
d6	Displays the external environment temperature (if the external probe is present) If the temperature is below zero, the value is displayed flashing.
d7	Display the temperature of the inlet DHW.

INSTALLER

USER

MAINTENANCE TECHNICIAN

### 3.9 PROGRAMMING THE P.C.B.

The boiler is prepared for possible programming of several operation parameters. By modifying these parameters as described below, the boiler can be adapted according to specific needs.

To access the programming phase, press “” and “RESET” simultaneously for approximately 8 seconds.

Once the menu has been accessed, it is possible to scroll through the three sub-menus present (s, p, t) by pressing the “” button for 2 seconds.

Use the "DHW regulator" selector (2), to select the parameter and rotate the "CH regulator" (1) to modify the value according to the range available.

With the menu active on the indicator (17) the parameter n° is displayed while indicator (21) displays the parameter value.

Press the "RESET" button for 2 seconds to memorise the variation of the parameters.

Memorisation is displayed by the flashing indicators (17 and 21). Exit the programming phase by waiting for 2 minutes or by pressing the “” and “RESET” simultaneously for 5 seconds.

Id Parameter	Parameter	Description	Range	Default
S0	Minimum central heating output	The boiler also has electronic modulation that adapts the boiler potentiality to the effective heating demand of the house. Then the boiler works normally in a variable gas pressure field between the minimum heating output and the maximum central heating output depending on the system's heating load.	0 - 60 %	set according to factory inspection
S1	Maximum central heating output	<b>Note:</b> the boiler is produced and calibrated in the central heating phase at nominal output. Approximately 10 minutes are needed to reach the nominal heat output, which can be changed using the parameter (S1). <b>Note:</b> the selection of the “Minimum heating output” and “Maximum heating output” parameters, in presence of a heating request, allows boiler ignition and power supply of the modulator with current equal to the value of the respective set value.	0 - 99 %	99
S2	Gas type selection	The setting of this function is used to adjust the boiler so that it can operate with the correct type of gas.	nG - Methane	nG
S3	Boiler type	Establishes the boiler type and its functioning mode 0 = combi 1 = 24 kW storage tank 2 = 28 kW storage tank 3 = 32kW storage tank	0 - 3	1
S4	Output ignition	Establishes the power at which the boiler must switch on	0 - 50 %	set according to factory inspection

Id Parameter	Parameter	Description	Range	Default
P0	D.H.W. thermostat	Establishes the switch-off method in DHW mode. 1 Correlated: a single calculation algorithm is used, regardless of the set boiler power. 0 Fixed: the curves depend on the boiler power set on the display.	0 - 1	1
P1	Solar delay timing	Not used	0 - 30 seconds	0



Id Parameter	Parameter	Description	Range	Default
P2	Pump functioning	The pump can function in two ways. 0 intermittent: in winter "mode" the circulator is managed by the room thermostat or by the remote control 1 continuous: in "winter" mode the circulator is always powered and is therefore always in operation	0 - 1	0
P3	Relay 1 (optional)	The boiler is set-up for functioning with the relay P.C.B. (optional), which can be configured 0 = Off 1 = Main zone control 2 = General alarm 3 = CH mode active 4 = External gas valve power supply 5 = Aquaceleris PTC control (Do not use on this boiler model)	0 - 5	0
P4	Relay 2 (optional)	The boiler is set-up for functioning with the relay P.C.B. (optional), which can be configured 0 = Off 1 = General alarm 2 = CH phase mode 3 = External gas valve power supply 4 = Secondary zone control (from TA on relay board contact)	0 - 4	0
P5	Relay 3 (optional)	The boiler is set-up for functioning with the relay P.C.B. (optional), which can be configured 0 = Off 1 = Chiller remote activation 2 = General alarm 3 = CH mode active 4 = External gas valve power supply 5 = Aquaceleris PTC control (Do not use on this boiler model)	0 - 5	0

INSTALLER

USER

Id Parameter	Parameter	Description	Range	Default
t0	Central heating ignitions timer	The boiler has an electronic timer, which prevents the burner from igniting too often in central heating mode	0 - 600 seconds	18
t1	Central heating ramp timer	In the ignition phase, the boiler performs an ignition ramp in order to arrive at the maximum power set	0 - 840 seconds	65
t2	CH ignition delay from TA and CR request	The boiler is set to switch-on immediately after a request. In the case of particular systems (e.g. area systems with motorised thermostatic valves etc.) it may be necessary to delay ignition.	0 - 600 seconds	0
t3	Display lighting	Establishes the display lighting mode. 0 <b>Automatic</b> : the display lights up during use and dims after 15 seconds of inactivity. In the event of an anomaly the display flashes. 1 <b>Off</b> : the display is always lit with low intensity 2 <b>On</b> : the display is always lit with high intensity.	0 - 2	0
t4	Display	Establishes what indicators 17 and 21 display (Fig. 13). 0 Indicator 17: displays the set DHW setting; Indicator 21: in winter mode it displays the set CH setting, while the indicator is switched off in summer mode 1 Indicator 17: it is switched off in the presence of a request. Without any request the indicator shows the set DHW setting. Indicator 21: in the presence of a request, it shows the instant flow temperature of the boiler. Without any request in summer mode, the indicator is off. In winter mode it shows the set CH setting.	0 - 1	1

MAINTENANCE TECHNICIAN

### 3.10 AUTOMATIC SOFT IGNITION FUNCTION.

In ignition phase, the P.C.B. supplies constant gas with pressure proportional to the parameter "S4" set.

### 3.11 "CHIMNEY SWEEP" FUNCTION.



When activated, this function forces the boiler to variable output for 15 minutes.

In this state all adjustments are excluded and only the safety thermostat and the limit thermostat remain active. To activate the chimney sweep function, press the "RESET" button until activation of the function in the absence of DHW requests.

Its activation is signalled by the indication of the flow temperature on the indicator (17), the power percentage on the indicator (21) and activation of the relative symbol .

This function allows the technician to check the combustion parameters.

Once the function is activated, it is possible to select whether to make the chick in CH status or DHW status by opening any hot water cock and regulating the power by turning the "CH regulation" selector (1).

Functioning in CH or DHW mode is visualised by the relative flashing symbols  or .

On completion of the checks, deactivate the function by pressing "RESET" for 8 seconds.

### 3.12 PUMP ANTI-BLOCK FUNCTION.

The boiler has a function that starts the pump once every 24 hours for the duration of 30 seconds in order to reduce the risk of the pump becoming blocked due to prolonged inactivity.

### 3.13 THREE-WAY ANTI-BLOCK SYSTEM.

The boiler is supplied with a function that activates the motorised three-way unit every 24 hours, carrying out a complete cycle in order to reduce the risk of three-way block due to prolonged inactivity.

### 3.14 RADIATORS ANTIFREEZE FUNCTION.

If the system return water is below 4°C, the boiler starts up until reaching 42°C.

### 3.15 PERIODICAL P.C.B. SELF-CHECK.

During functioning in central heating mode or with boiler in standby, the function activates every 18 hours after the last boiler check/power supply. In case of functioning in domestic hot water mode the self-check starts within 10 minutes after the end of the withdrawing in progress, for duration of approx. 10 seconds.

**N.B.:** during self-check, the boiler remains off, including signalling.

### 3.16 CASING REMOVAL.

To facilitate boiler maintenance the casing can be completely removed as follows (Fig. 18, 19 e 20):

- 1- Undo the 2 bottom screws (b) that fasten the protection guard (a).
- 2- Release the guard (a).
- 3- Unhook the decorative frame (c) from the relative lower retainers.
- 4- Remove the decorative frame (c) from the casing (e).
- 5- Loosen the 2 front screws (d) that fasten the cover.

#### Installation drawings key:

**a** Unmistakeable component identification

**1** Sequential identification of the operation to perform

- 6- Remove the cover's protect caps (f).
- 7- Loosen the 2 front screws (g) that fasten the cover.
- 8- Loosen the 2 lower screws (h) that fasten the cover.
- 9- Pull the cover towards you (e).
- 10 - Loosen the 2 lower screws (j) that fasten the casing.
- 11 - At the same time, push the casing (k) upwards to release it from the upper cross member.
- 12 - Loosen the control panel fixing screw (l) from the base of the frame and open it downwards.
- 13 - Unscrew the 4 fixing screws of the sides (m).
- 14 - Remove the sides (n) from the relative hooks (X) on the frame.

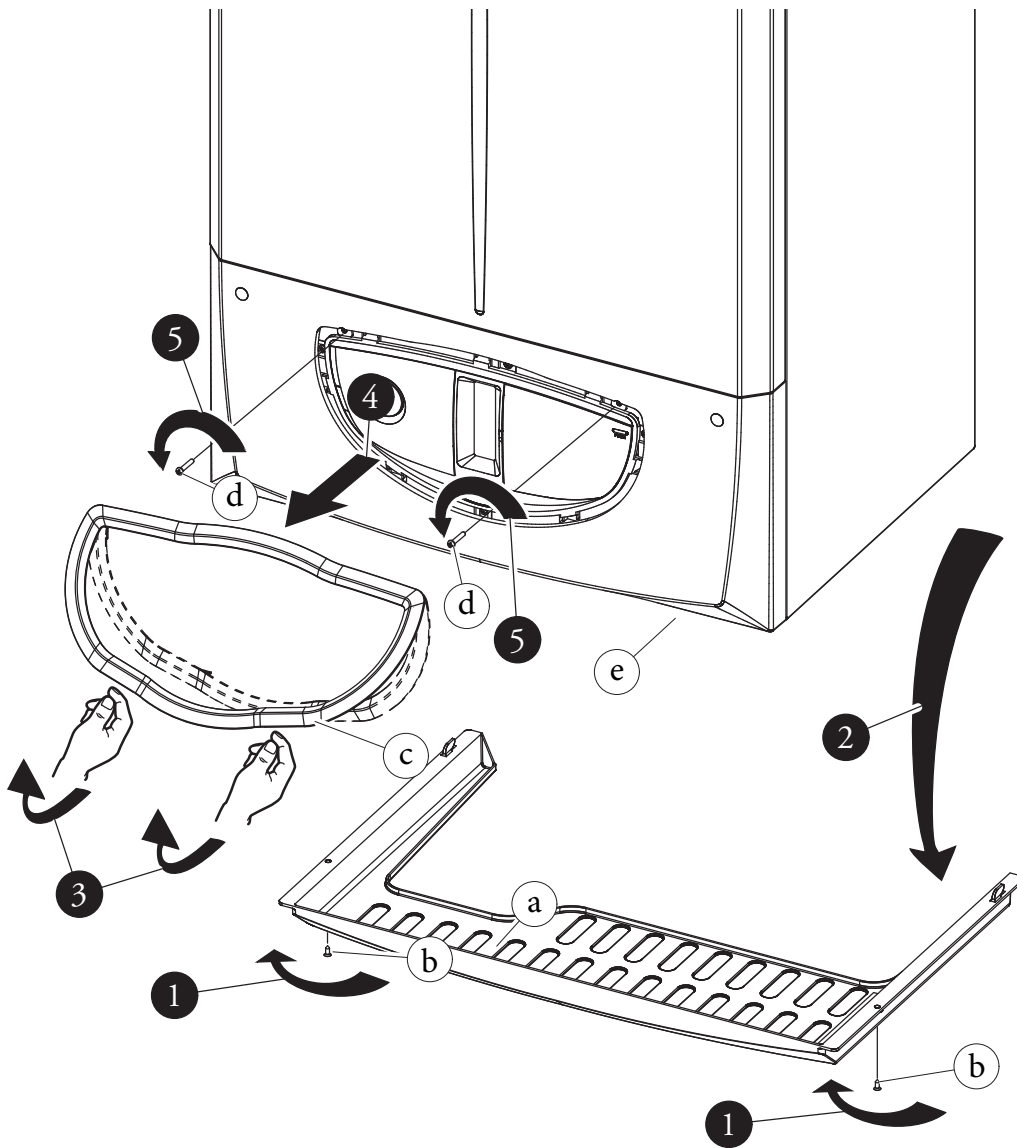

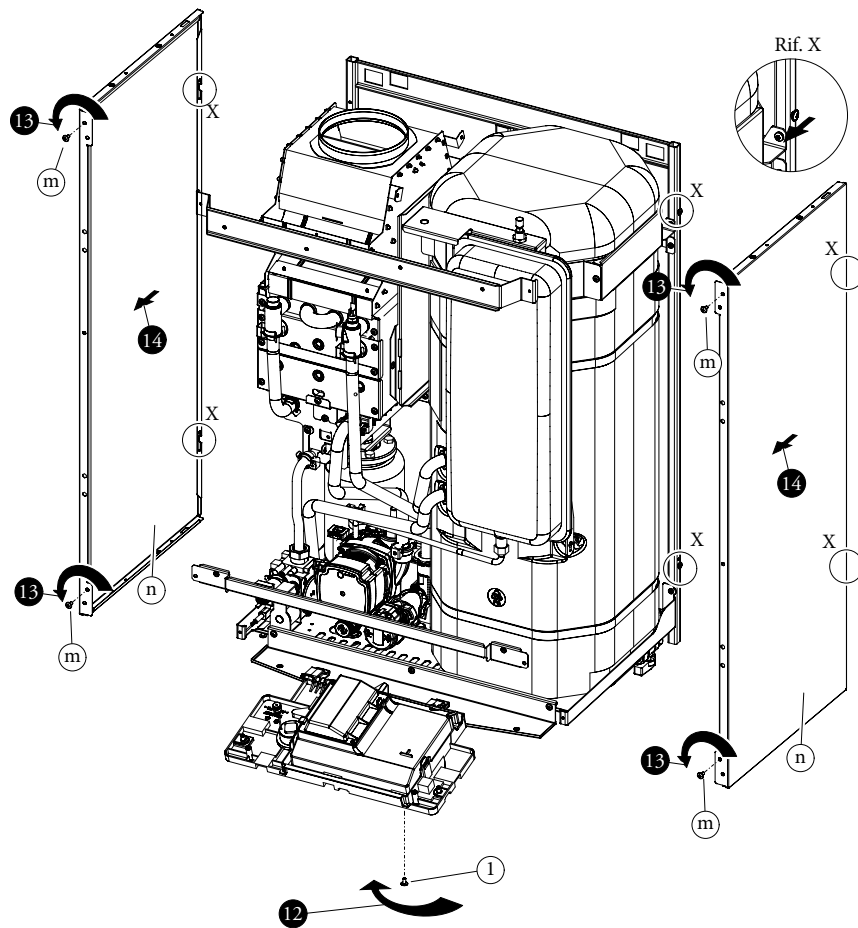
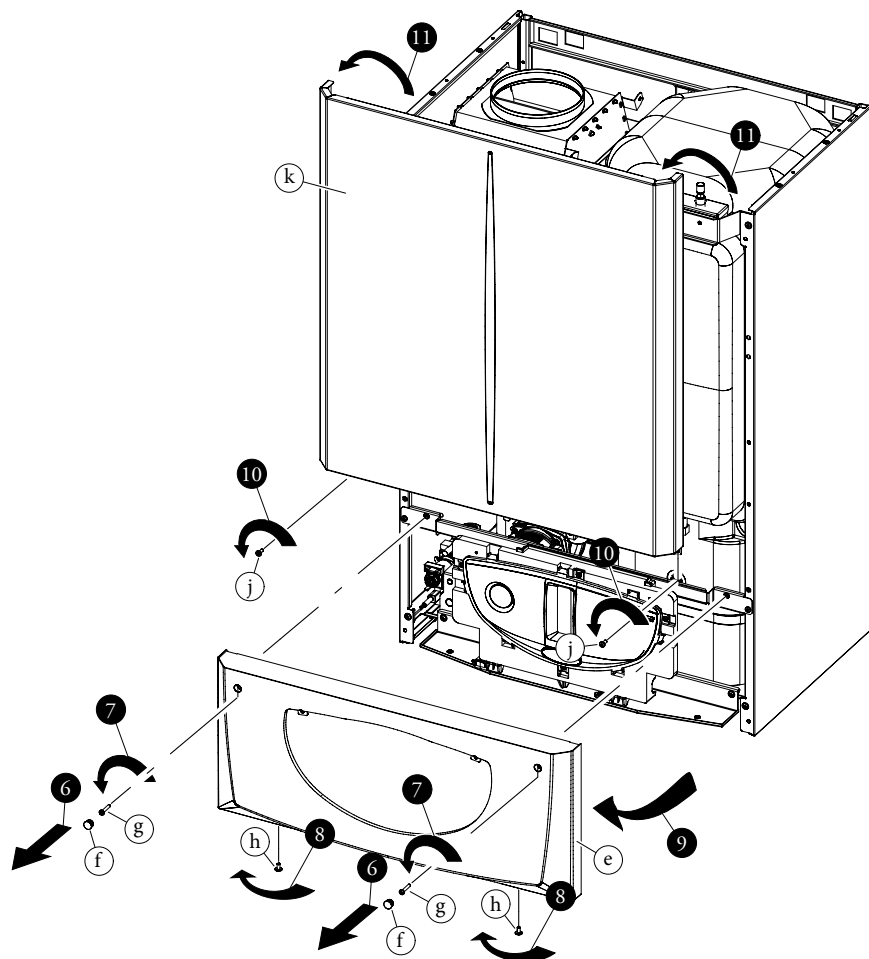

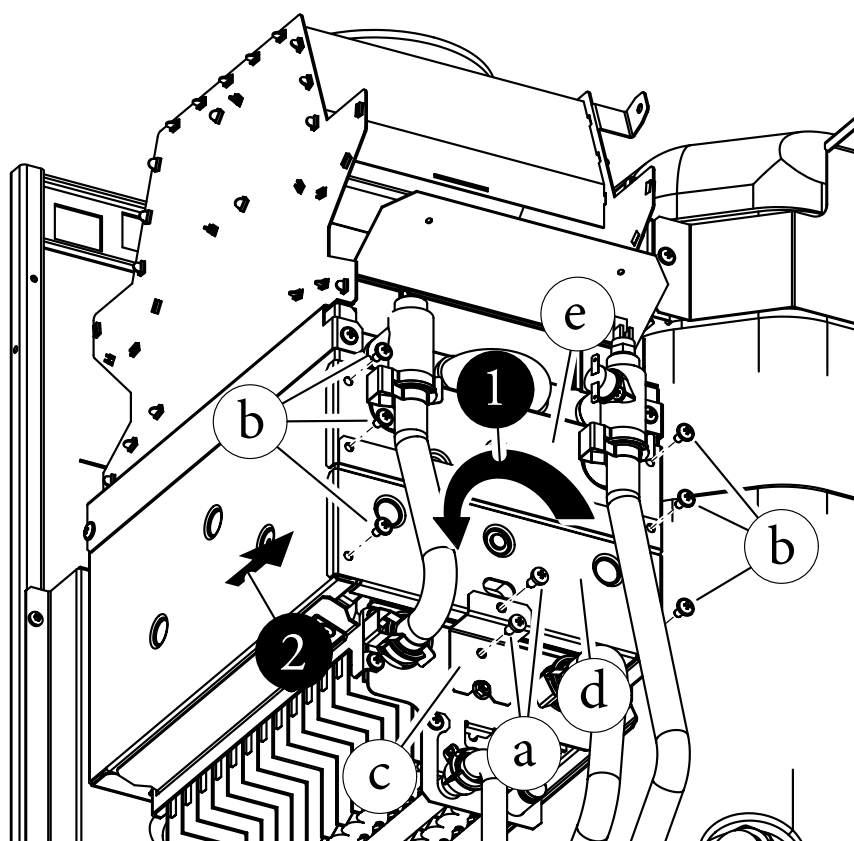

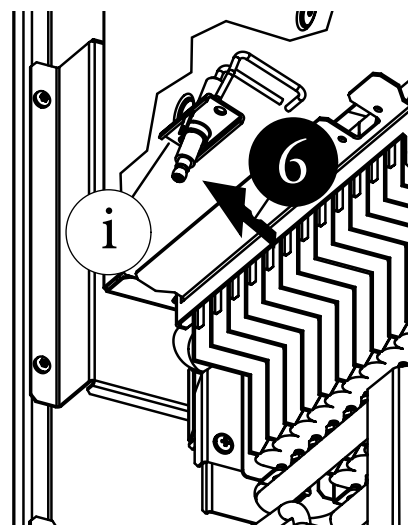
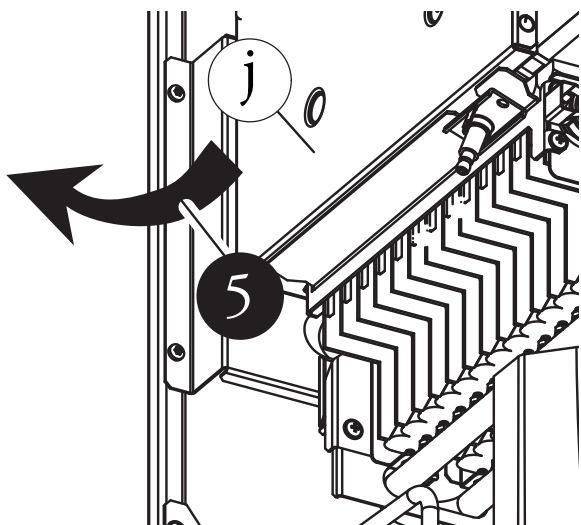
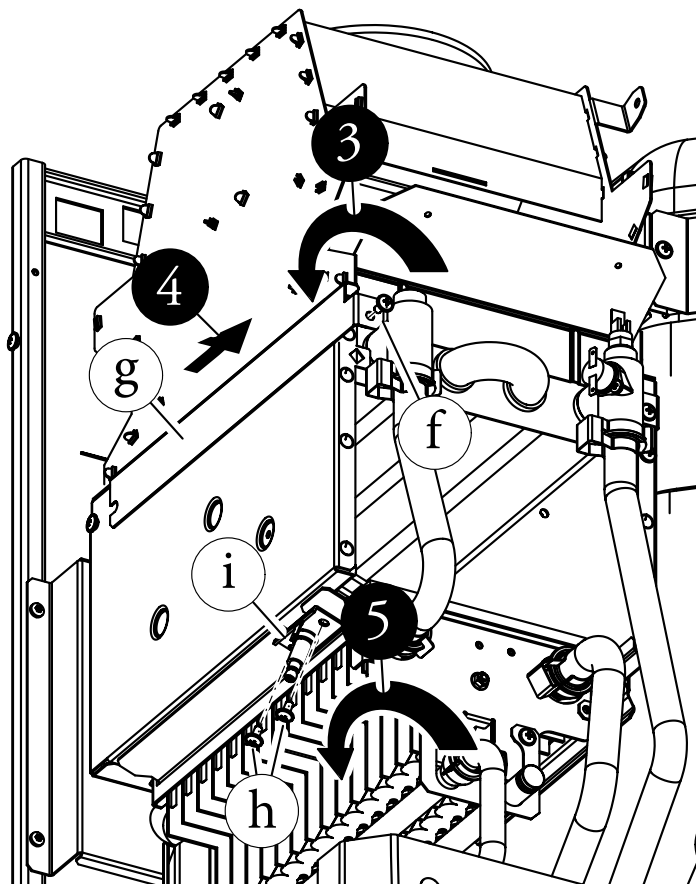

## 4 TECHNICAL DATA.

### 4.1 VARIABLE HEAT OUTPUT.

**N.B.:** gas flow rates refer to net calorific value at a temperature of 15°C and pressure of 1013 mbar. Burner pressure values refer to use of gas at 15°C.

	METHANE (G20)				
	HEAT THERMAL	HEAT THERMAL	GAS FLOW RATE BURNER	PRESS. NOZZLE BURNER	
	(kW)	(kcal/h)	(m <sup>3</sup> /h)	(mbar)	(mm H <sub>2</sub> O)
MAX.	24.0	20640	2.82	13.90	141.7
MIN. HEAT	10.4	8944	1.24	3.00	30.6
MIN. DHW	9.5	8170	1.13	2.50	25.5

### 4.2 COMBUSTION PARAMETERS.

		<b>G20</b>
Supply pressure	mbar (mm H <sub>2</sub> O)	20 (204)
Gas nozzle diameter	mm	0.82
Flue flow rate at nominal heat output	kg/h (g/s)	73 (20.27)
Flue flow rate at min DHW / heat output	kg/h (g/s)	56 (15.56) / 57 (15.83)
CO <sub>2</sub> at Q. Nom./Min. DHW/Min. heat output	%	5.10 / 2.60 / 2.75 (± 0.2)
CO with 0% O <sub>2</sub> at Nom./Min. Q.	ppm	75 / 25
NO <sub>x</sub> with 0% O <sub>2</sub> at Nom./Min. Q.	mg/kWh	80 / 33
Flue temperature at nominal output	°C	95
Flue temperature at minimum output	°C	64

Combustion parameters: measuring conditions of useful efficiency (flow temperature/return temperature= 80 / 60 °C), ambient temperature reference = 15°C.

### 4.3 TECHNICAL DATA TABLE.

Domestic hot water nominal heat input	kW (kcal/h)	26,6 (22908)
Central heating nominal heat input	kW (kcal/h)	26,6 (22908)
Minimum DHW heat input	kW (kcal/h)	10,7 (9211)
Central heating minimum heat input	kW (kcal/h)	11,7 (10038)
Domestic hot water nominal heat output (useful)	kW (kcal/h)	24,0 (20640)
Central heating nominal heat output (useful)	kW (kcal/h)	24,0 (20640)
Minimum heat output (useful)	kW (kcal/h)	9,5 (8170)
	kW (kcal/h)	10,4 (8944)
*Effective thermal efficiency Nom./Min.	%	90,1 / 89,1
Casing losses with burner On/Off (80-60°C)	%	1,42 - 3,3
Chimney losses with burner On/Off (80-60°C)	%	0,08 - 6,6
Central heating circuit max. operating pressure	bar (MPa)	3,0 (0,3)
Maximum heating temperature	°C	90
Adjustable central heating temperature (max operating field)	°C	35 - 85
System expansion vessel total volume	l	7,7
Expansion vessel pre-charged pressure	bar (MPa)	1,0 (0,1)
	l	1,2
	bar (MPa)	3,5 (0,35)
Appliance water content	l	45,2
Head available with 1000 l/h flow rate	kPa (m H <sub>2</sub> O)	26,6 (2,7)
Hot water production useful heat output	kW (kcal/h)	24,0 (20640)
Domestic hot water adjustable temperature	°C	10 - 60
Domestic hot water circuit min. pressure (dynamic)	bar (MPa)	0,3 (0,03)
Domestic hot water circuit max. operating pressure	bar (MPa)	8,0 (0,8)
Flow rate capacity in continuous duty ( $\Delta T$ 30°C)	l/min	11,2
Weight of full boiler	kg	97,2
Weight of empty boiler	kg	52,0
Electrical connection	V/Hz	230 / 50
Nominal power absorption	A	0,4
Installed electric power	W	50
Pump absorbed power	W	33
EEI value	-	≤ 0,20 - Part. 3
Equipment electrical system protection	-	IPX5D
Ambient operating temperature range	°C	0 ÷ + 50
NO <sub>x</sub> class	-	6
Weighted NO <sub>x</sub>	mg/kWh	29
Weighted CO	mg/kWh	27
Type of appliance	B11 <sub>BS</sub>	
Category	I 2H	

- The data relating to domestic hot water performance refer to a dynamic inlet pressure of 2 bar and an inlet temperature of 15°C; the values are measured immediately at the boiler outlet, considering that to obtain the data declared, mixing with cold water is required.

- \* Efficiencies refer to the net calorific value.

- The weighted NO<sub>x</sub> value refer to the net calorific value.



#### 4.4 KEY FOR DATA NAMEPLATE.

Md		Cod. Md	
Sr N°	CHK	Cod. PIN	
Type			
Q <sub>nw</sub> /Q <sub>n</sub> min.	Q <sub>nw</sub> /Q <sub>n</sub> max.	P <sub>n</sub> min.	P <sub>n</sub> max.
PMS	PMW	D	TM
NO <sub>x</sub> Class			

**Note:** the technical data is provided on the data nameplate on the boiler

	ENG
Md	Model
Code Md	Model code
Sr N°	Serial Number
CHK	Check
Code PIN	PIN code
Type	Type of installation (ref. CEN TR 1749)
Q <sub>nw</sub> min.	Minimum DHW heat input
Q <sub>n</sub> min.	Central heating minimum heat input
Q <sub>nw</sub> max.	DHW maximum heat input
Q <sub>n</sub> max.	Central heating maximum heat input
P <sub>n</sub> min.	Minimum heat output
P <sub>n</sub> max.	Maximum heat output
PMS	Maximum system pressure
PMW	Maximum domestic hot water pressure
D	Specific flow rate
TM	Maximum operating temperature
NO <sub>x</sub> Class	NO <sub>x</sub> Class

#### 4.5 TECHNICAL PARAMETERS FOR COMBINATION BOILERS (IN COMPLIANCE WITH REGULATION 813/2013).

The efficiencies and NO<sub>x</sub> values in the following tables refer to the gross calorific value.

Model/s:				Avio Eco 24				
Condensing Boilers:				NO				
Low temperature boiler:				NO				
Boiler type B1:				YES				
Co-generation appliance for central heating:				NO		Fitted with supplementary heating system:		NO
Mixed heating appliance:				YES				
Element	Symbol	Value	Unit	Element	Symbol	Value	Unit	
Nominal heat output	P <sub>n</sub>	24	kW	Seasonal energy efficiency of central heating	η <sub>s</sub>	77	%	
For central heating only and combination boilers: useful heat output				For central heating only and combination boilers: useful efficiency				
At nominal heat output in high temperature mode (*)	P <sub>4</sub>	24.0	kW	At nominal heat output in high temperature mode (*)	η <sub>4</sub>	80,8	%	
At 30% of nominal heat output in a low temperature mode (**)	P <sub>1</sub>	7,1	kW	At 30% of nominal heat output in a low temperature mode (**)	η <sub>1</sub>	80,5	%	
Auxiliary electricity consumption				Other items				
At full load	el <sub>max</sub>	0.011	kW	Heat loss in standby	P <sub>stby</sub>	0,199	kW	
At partial load	el <sub>min</sub>	0.011	kW	Ignition burner energy consumption	P <sub>ign</sub>	0,000	kW	
In standby mode	P <sub>SB</sub>	0.002	kW	Emissions of nitrogen oxides	NO <sub>x</sub>	26	mg / kWh	
For mixed central heating appliances								
Stated load profile	XL			Domestic hot water production efficiency	η <sub>WH</sub>	72	%	
Daily electrical power consumption	Q <sub>elec</sub>	0.100	kWh	Daily gas consumption	Q <sub>fuel</sub>	28,750	kWh	
Contact information	IMMERGAS S.p.A. VIA CISA LIGURE, 95 - 42041 BRESCELLO (RE) ITALY							
(*) High temperature mode means 60°C on return and 80°C on flow.								
(**) Low temperature mode for condensation Boilers means 30°C , for low temperature boilers 37°C and for other appliances 50°C of return temperature.								

#### 4.6 PRODUCT FICHE (IN COMPLIANCE WITH REGULATION 811/2013).

##### Avio Eco 24

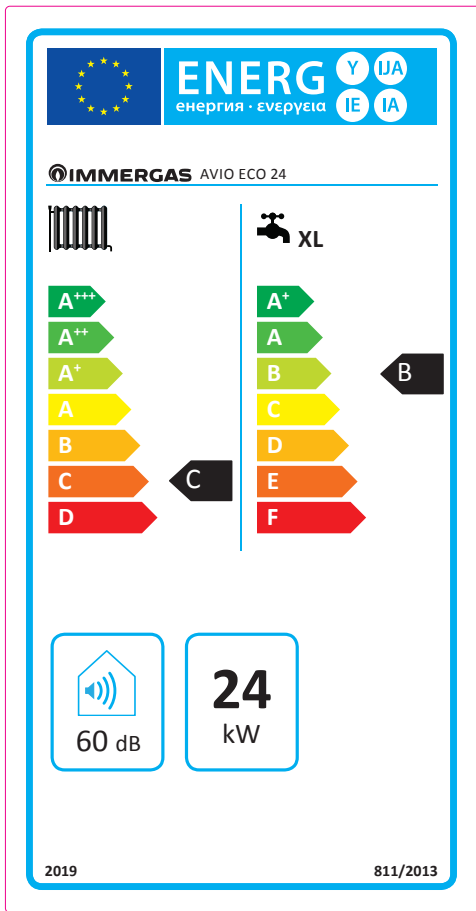

Parameter	value
Annual energy consumption for the central heating mode ( $Q_{HE}$ )	65,0 GJ
Annual electricity consumption for the domestic hot water function (AEC)	22 kWh
Annual fuel consumption for the domestic hot water function (AFC)	21,0 GJ
Seasonal space heating energy efficiency ( $\eta_s$ )	77 %
Water heating energy efficiency ( $\eta_{wh}$ )	72 %

For proper installation of the device, refer to chapter 1 of this booklet (for the installer) and current installation regulations. For proper maintenance refer to chapter 3 of this booklet (for the maintenance technician) and adhere to the frequencies and methods set out herein.

#### 4.7 PARAMETERS FOR FILLING IN THE PACKAGE FICHE.

If you wish to install an assembly, starting from the Avio Eco 24 boiler, use the assembly charts in Fig. 27 and 30).

To complete it properly, fill the relevant spaces (as shown in the package fiche facsimile (Fig. 26 and 29) with the values shown in tables (Fig. 25 and 28).

The remaining values must be obtained from the technical data sheets of the products used to make up the assembly (e.g. solar devices, integration heat pumps, temperature controllers).

Use board (Fig. 27) for “assemblies” related to the central heating mode (e.g.: boiler + temperature controller).

Use board (Fig. 30) for “assemblies” related to the domestic hot water function (e.g.: boiler + solar thermal system).

#### Facsimile for filling in the package fiche for room central heating systems.

Seasonal central heating energy efficiency of the boiler		<b>1</b>	<input type="text" value="'I'"/>	%
Temperature control From temperature control board	Class I = 1 %, Class II = 2 %, Class III = 1.5 %, Class IV = 2 %, Class V = 3 %, Class VI = 4 %, Class VII = 3.5 %, Class VIII = 5 %	<b>2</b>	+ <input type="text"/>	%
Supplementary boiler From boiler board	Seasonal central heating energy efficiency (in %)	<b>3</b>	( <input type="text"/> - 'I' ) x 0.1 = ± <input type="text"/>	%
Solar contribution From the board of the solar device	<div style="display: flex; justify-content: space-around;"> <div>Dimensions of the manifold (in m<sup>2</sup>)</div> <div>Volume of the tank (in m<sup>3</sup>)</div> <div>Efficiency of the manifold (in %)</div> </div> Classification of the tank A* = 0.95, A = 0.91, B = 0.86, C = 0.83, D-G = 0.81	<b>4</b>	( 'III' x <input type="text"/> + 'IV' x <input type="text"/> ) x (0.9 x ( <input type="text"/> / 100 ) x <input type="text"/>	= + <input type="text"/> %
Supplementary heat pump From the heat pump board	Seasonal central heating energy efficiency (in %)	<b>5</b>	( <input type="text"/> - 'I' ) x 'II'	= + <input type="text"/> %
Solar contribution and supplementary heat pump	Select the lowest value	<b>6</b>	0.5 x <input type="text"/> O 0.5 x <input type="text"/>	= - <input type="text"/> %
Seasonal central heating energy efficiency of the set		<b>7</b>	<input type="text"/>	%
Seasonal central heating energy efficiency class of the set	<div style="border: 1px solid black; padding: 5px; text-align: center;"> <input type="checkbox"/> <input type="checkbox"/> <input type="checkbox"/> <input type="checkbox"/> <input type="checkbox"/> <input type="checkbox"/> <input type="checkbox"/> <input type="checkbox"/> <input type="checkbox"/> <input type="checkbox"/>   <b>G</b> <b>F</b> <b>E</b> <b>D</b> <b>C</b> <b>B</b> <b>A</b> <b>A<sup>+</sup></b> <b>A<sup>++</sup></b> <b>A<sup>+++</sup></b>             &lt; 30 % ≥ 30 % ≥ 34 % ≥ 36 % ≥ 75 % ≥ 82 % ≥ 90 % ≥ 98 % ≥ 125 % ≥ 150 %         </div>			
Boiler and supplementary heat pump installed with low temperature heat emitters at 35 °C?		<b>7</b>	<input type="text"/>	
From the board of the heat pump			+ ( 50 x 'II' ) = <input type="text"/>	%
<p>The energy efficiency of the set of products indicated in this sheet may not reflect the actual energy efficiency after installation since such efficiency is affected by additional factors, such as the heat loss in the distribution system and the size of the products compared to the size and features of the building.</p>				

**Parameters for filling in the assembly chart.**

Parameter	Avio Eco 24
'I'	77
'II'	*
'III'	1.11
'IV'	0.43

\* to be established by means of table 5 of Regulation 811/2013 in case of "assembly" including a heat pump to integrate the boiler. In this case the boiler must be considered as the main appliance of the assembly.

**Room central heating system package fiche.**

Seasonal central heating energy efficiency of the boiler ①  %

---

Temperature control ②  %  
 From temperature control board  
 Class I = 1 %, Class II = 2 %, Class III = 1.5 %, Class IV = 2 %, Class V = 3 %, Class VI = 4 %, Class VII = 3.5 %, Class VIII = 5 %

---

Supplementary boiler ③  %  
 From boiler board  
 Seasonal central heating energy efficiency (in %)   
 $( \text{ } - \text{ } ) \times 0.1 = \pm \text{ } \%$

---

Solar contribution ④  %  
 From the board of the solar device  
 Dimensions of the manifold (in m<sup>2</sup>)  Volume of the tank (in m<sup>3</sup>)  Efficiency of the manifold (in %)   
 Classification of the tank: A\* = 0.95, A = 0.91, B = 0.86, C = 0.83, D-G = 0.81  
 $( \text{ } \times \text{ } + \text{ } \times \text{ } ) \times (0.9 \times ( \text{ } / 100 ) \times \text{ } = + \text{ } \%$

---

Supplementary heat pump ⑤  %  
 From the heat pump board  
 Seasonal central heating energy efficiency (in %)   
 $( \text{ } - \text{ } ) \times \text{ } = + \text{ } \%$

---

Solar contribution and supplementary heat pump ⑥  %  
 Select the lowest value  $0.5 \times \text{ } \text{ O } 0.5 \times \text{ } = - \text{ } \%$

---

Seasonal central heating energy efficiency of the set ⑦  %

---

Seasonal central heating energy efficiency class of the set

<input type="checkbox"/>	<input type="checkbox"/>	<input type="checkbox"/>	<input type="checkbox"/>	<input type="checkbox"/>	<input type="checkbox"/>	<input type="checkbox"/>	<input type="checkbox"/>	<input type="checkbox"/>	<input type="checkbox"/>
<b>G</b>	<b>F</b>	<b>E</b>	<b>D</b>	<b>C</b>	<b>B</b>	<b>A</b>	<b>A<sup>+</sup></b>	<b>A<sup>++</sup></b>	<b>A<sup>+++</sup></b>
< 30 %	≥ 30 %	≥ 34 %	≥ 36 %	≥ 75 %	≥ 82 %	≥ 90 %	≥ 98 %	≥ 125 %	≥ 150 %

---

Boiler and supplementary heat pump installed with low temperature heat emitters at 35 °C?  
 From the board of the heat pump ⑦  + ( 50 x  ) =  %

The energy efficiency of the set of products indicated in this sheet may not reflect the actual energy efficiency after installation since such efficiency is affected by additional factors, such as the heat loss in the distribution system and the size of the products compared to the size and features of the building.

Facsimile for filling in the domestic hot water production system package fiche.

Water heating energy efficiency of combination boiler ①  %

Stated load profile:

Solar contribution

From the board of the solar device

Auxiliary electricity

  
↓

$$(1.1 \times \text{'I'} - 10\%) \times \text{'II'} - \text{'III'} - \text{'I'} = + \text{} \%$$

Water heating energy efficiency of the assembly in average climate conditions ③  %

Water heating energy efficiency class of the assembly in average climate conditions

	<input type="checkbox"/>	<input type="checkbox"/>	<input type="checkbox"/>	<input type="checkbox"/>	<input type="checkbox"/>	<input type="checkbox"/>	<input type="checkbox"/>	<input type="checkbox"/>	<input type="checkbox"/>	<input type="checkbox"/>
	<b>G</b>	<b>F</b>	<b>E</b>	<b>D</b>	<b>C</b>	<b>B</b>	<b>A</b>	<b>A<sup>+</sup></b>	<b>A<sup>++</sup></b>	<b>A<sup>+++</sup></b>
<input type="checkbox"/> <b>M</b>	< 27 %	≥ 27 %	≥ 30 %	≥ 33 %	≥ 36 %	≥ 39 %	≥ 65 %	≥ 100 %	≥ 130 %	≥ 163 %
<input type="checkbox"/> <b>L</b>	< 27 %	≥ 27 %	≥ 30 %	≥ 34 %	≥ 37 %	≥ 50 %	≥ 75 %	≥ 115 %	≥ 150 %	≥ 188 %
<input type="checkbox"/> <b>XL</b>	< 27 %	≥ 27 %	≥ 30 %	≥ 35 %	≥ 38 %	≥ 55 %	≥ 80 %	≥ 123 %	≥ 160 %	≥ 200 %
<input type="checkbox"/> <b>XXL</b>	< 28 %	≥ 28 %	≥ 32 %	≥ 36 %	≥ 40 %	≥ 60 %	≥ 85 %	≥ 131 %	≥ 170 %	≥ 213 %

Water heating energy efficiency class in colder and hotter climate conditions

Colder: ③ - 0.2 x ② =    %

Hotter: ③ + 0.4 x ② =    %

*The energy efficiency of the set of products indicated in this sheet may not reflect the actual energy efficiency after installation since such efficiency is affected by additional factors, such as the heat loss in the distribution system and the size of the products compared to the size and features of the building.*

Parameters for filling in the DHW package fiche.

Parameter	Avio Eco 24
‘I’	72
‘II’	*
‘III’	*

\* to be determined according to Regulation 811/2013 and transient calculation methods as per Notice of the European Community no. 207/2014.

29

Domestic hot water production system package fiche.

Water heating energy efficiency of combination boiler

%

Stated load profile:

Solar contribution

From the board of the solar device

Auxiliary electricity

( 1.1 x \_\_\_\_\_ - 10 % ) x \_\_\_\_\_ -  - \_\_\_\_\_ = +  %

Water heating energy efficiency of the assembly in average climate conditions

%

Water heating energy efficiency class of the assembly in average climate conditions

	<input type="checkbox"/>	<input type="checkbox"/>	<input type="checkbox"/>	<input type="checkbox"/>	<input type="checkbox"/>	<input type="checkbox"/>	<input type="checkbox"/>	<input type="checkbox"/>	<input type="checkbox"/>	<input type="checkbox"/>
	G	F	E	D	C	B	A	A <sup>+</sup>	A <sup>++</sup>	A <sup>+++</sup>
<input type="checkbox"/> M	< 27 %	≥ 27 %	≥ 30 %	≥ 33 %	≥ 36 %	≥ 39 %	≥ 65 %	≥ 100 %	≥ 130 %	≥ 163 %
<input type="checkbox"/> L	< 27 %	≥ 27 %	≥ 30 %	≥ 34 %	≥ 37 %	≥ 50 %	≥ 75 %	≥ 115 %	≥ 150 %	≥ 188 %
<input type="checkbox"/> XL	< 27 %	≥ 27 %	≥ 30 %	≥ 35 %	≥ 38 %	≥ 55 %	≥ 80 %	≥ 123 %	≥ 160 %	≥ 200 %
<input type="checkbox"/> XXL	< 28 %	≥ 28 %	≥ 32 %	≥ 36 %	≥ 40 %	≥ 60 %	≥ 85 %	≥ 131 %	≥ 170 %	≥ 213 %

Water heating energy efficiency class in colder and hotter climate conditions

Colder:  - 0.2 x  =  %

Hotter:  + 0.4 x  =  %

The energy efficiency of the set of products indicated in this sheet may not reflect the actual energy efficiency after installation since such efficiency is affected by additional factors, such as the heat loss in the distribution system and the size of the products compared to the size and features of the building.

30



[immergas.com](http://immergas.com)

Immergas S.p.A.  
42041 Brescello (RE) - Italy  
Tel. 0522.689011  
Fax 0522.680617

**Certified company ISO 9001**

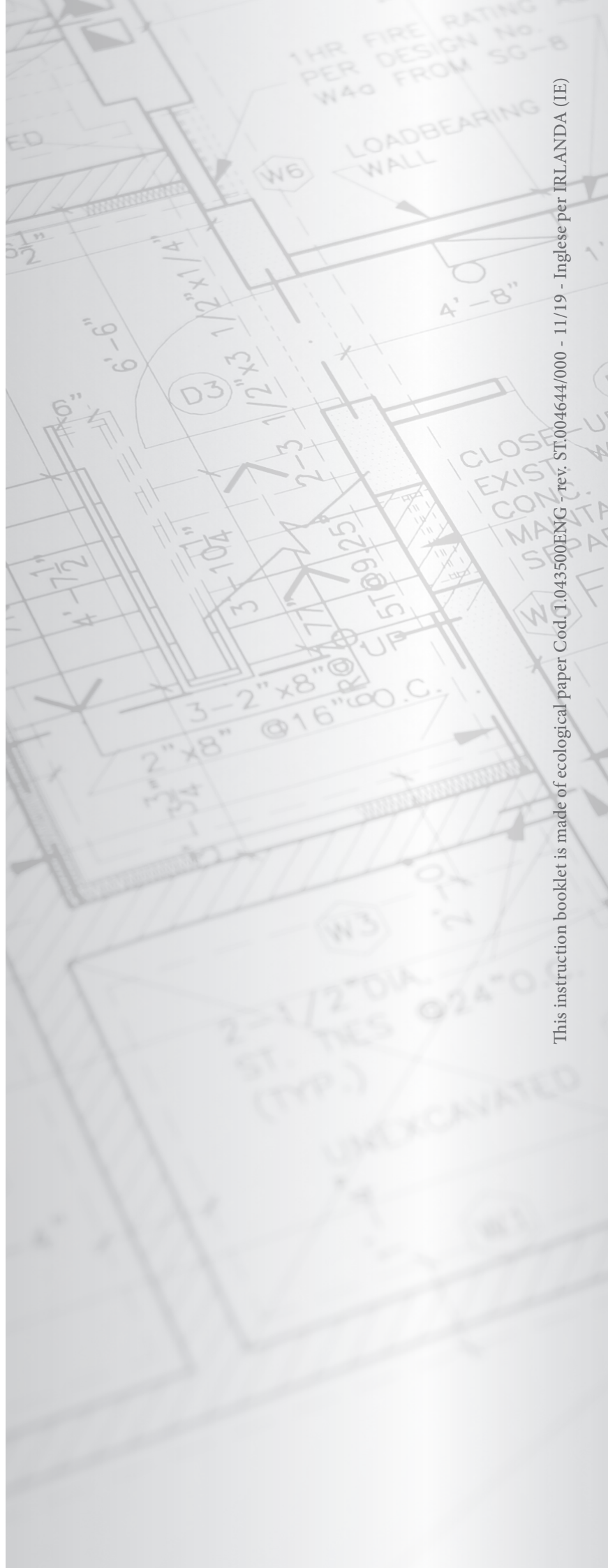

This instruction booklet is made of ecological paper Cod. 1.043500ENG - rev. ST.004644/000 - 11/19 - Inglese per IRLANDA (IE)