

MANUALS
USERS

Instruction and **IE**
warning book

 **IMMERGAS**

NIKE MYTHOS
242 E

1.038789ENG



Dear Customer,

Our compliments for having chosen a top-quality Immergas product, able to assure well-being and safety for a long period of time. As an Immergas customer you can also count on a qualified after-sales service, prepared and updated to guarantee constant efficiency of your boiler. Read the following pages carefully: you will be able to draw useful suggestions regarding the correct use of the appliance, the respect of which, will confirm your satisfaction for the Immergas product. For assistance and scheduled maintenance contact Authorised Immergas After-Sales centres: they have original spare parts and are specifically trained directly by the manufacturer.

General recommendations

All Immergas products are protected with suitable transport packaging.

The material must be stored in dry environments protected against bad weather.

The instruction book is an integral and essential part of the product and must be consigned to the new user also in the case of transfer or succession of ownership.

It must be stored with care and consulted carefully, as all of the warnings provide important safety indications for installation, use and maintenance stages.

This instructions manual provides technical information for installing Immergas boilers. As for the other issues related to boiler installation (e.g. safety in the work site, environment protection, injury prevention), it is necessary to comply with the provisions specified in the regulations in force and principles of good practice.

In compliance with legislation in force, the systems must be designed by qualified professionals, within the dimensional limits established by the Law. Installation and maintenance must be performed in compliance with the regulations in force, according to the manufacturer's instructions and by professionally qualified staff, intending staff with specific technical skills in the plant sector, as envisioned by the Law.

Improper installation or assembly of the Immergas appliance and/or components, accessories, kit and devices can cause unexpected problems to people, animals and objects. Read the instructions provided with the product carefully to ensure a proper installation.

Maintenance must be carried out by skilled technical staff. The Immergas Authorised After-sales Service represents a guarantee of qualifications and professionalism.

The appliance must only be destined for the use for which it has been expressly declared. Any other use will be considered improper and therefore potentially dangerous.

If errors occur during installation, operation and maintenance, due to non compliance with technical laws in force, standards or instructions contained in this book (or however supplied by the manufacturer), the manufacturer is excluded from any contractual and extra-contractual liability for any damages and the appliance warranty is invalidated.

Product not intended for EU countries

The manufacturer declines all liability due to printing or transcription errors, reserving the right to make any modifications to its technical and commercial documents without prior notice.

INDEX

INSTALLER

page

1	Boiler installation.....	4
1.1	Installation recommendations.....	4
1.2	Main dimensions.....	5
1.3	Connections (Optional).....	5
1.4	Remote controls and room chrono- thermostats (Optional).....	6
1.5	Ventilation of the rooms.....	7
1.6	Flue ducts.....	7
1.7	Flues/Chimneys.....	7
1.8	System filling.....	7
1.9	Gas system start-up.....	7
1.10	Boiler commissioning (ignition).....	8
1.11	Circulation pump.....	8
1.12	Kits available on request.....	8
1.13	Boiler components.....	9

USER

page

2	Instructions for use and maintenance..	10
2.1	Cleaning and maintenance.....	10
2.2	Ventilation of the rooms.....	10
2.3	General warnings.....	10
2.4	Control panel.....	10
2.5	Troubleshooting.....	11
2.6	Restoring central heating system pressure.....	11
2.7	System draining.....	11
2.8	Anti-freeze protection.....	12
2.9	Case cleaning.....	12
2.10	Decommissioning.....	12

MAINTENANCE TECHNICIAN

page

3	Boiler commissioning (initial check).....	13
3.1	Hydraulic diagram.....	13
3.2	Wiring diagram.....	14
3.3	Troubleshooting.....	14
3.4	Converting the boiler to other types of gas.....	15
3.5	Checks following conversion to another type of gas.....	15
3.6	Possible adjustments.....	15
3.7	Programming the P.C.B.....	15
3.8	Automatic slow ignition function with timed ramp delivery.....	16
3.9	"Chimney sweep function".....	16
3.10	Heating Timer.....	16
3.11	Pump anti-block function.....	16
3.12	Radiators anti-freeze function.....	16
3.13	P.C.B. periodical self-check.....	16
3.14	Casing removal.....	17
3.15	Yearly appliance check and maintenance.....	18
3.16	Variable heat output.....	18
3.17	Combustion parameters.....	19
3.18	Technical data.....	19
3.19	Data plate key.....	20

1 BOILER INSTALLATION

1.1 INSTALLATION RECOMMENDATIONS.

The Nike Mythos 24 2E boiler has been designed for wall mounted installation only, for heating environments and production of domestic hot water for domestic use and similar purposes.

The place of installation of the appliance and relative Immergas accessories must have suitable features (technical and structural) such to allow (always in safety, efficiency and comfortable conditions):

- installation (according to the provisions of the technical legislation and technical regulations);
- maintenance operations (including scheduled, periodic, routine and special maintenance);
- removal (to outdoors in the place for loading and transporting the appliances and components) as well as their eventual replacement with appliances and/or equivalent components.

The wall surface must be smooth, without any protrusions or recesses enabling access to the rear part. They are not designed to be installed on plinths or floors (Fig. 1-1).

Only professionally enabled companies are authorised to install Immergas gas appliances. Installation must be carried out according to regulation standards, current legislation and in compliance with local technical regulations and the required technical procedures.

Attention: the manufacturer declines all liability for damages caused by boilers removed from other systems or for any non-conformities of such equipment.

Before installing the appliance, ensure that it is delivered in perfect condition; if in doubt, contact the supplier immediately. Packing materials (staples, nails, plastic bags, polystyrene foam, etc.) constitute a hazard and must be kept out of the reach of children. If the appliance is installed inside or between cabinets, ensure sufficient space for normal servicing; therefore it is advisable to leave clearance of at least 3 cm between the boiler casing and the vertical sides of the cabinet. Leave adequate space above the boiler for possible water and flue removal connections. It is just as important that the intake grids are not obstructed. Keep all flammable objects away from the appliance (paper, rags, plastic, polystyrene, etc.). Do not place household appliances underneath the boiler as they could be damaged if the safety valve intervenes with an obstructed conveying system (the safety valve must be conveyed away by a draining funnel), or

if there are leaks from the hydraulic connections; on the contrary, the manufacturer cannot be held responsible for any damage caused to the household appliances.

For the aforementioned reasons, we recommend not placing furnishings, furniture, etc. under the boiler.

In the event of malfunctions, faults or incorrect operation, turn the appliance off immediately and contact an authorised company (e.g. the Immergas Technical Assistance centre, which has specifically trained staff and original spare parts). Do not attempt to modify or repair the appliance alone. Failure to comply with the above implies personal responsibility and invalidates the warranty.

• Installation regulations:

- these boilers cannot be installed in bedrooms, studio flats and bathrooms. They also cannot be installed in rooms with wood (or solid fuel) burning heat generators and in adjacent and communicating rooms;
- installation in places with a fire risk is prohibited (for example: garages, closed parking stalls), gas appliances and relative flue ducts, flue exhaust pipes and combustion air intake pipes;
- installation is prohibited on the vertical projection of cooking hobs;
- installation is also prohibited in places/environments that constitute common parts of office condominiums such as stairs, cellars, entrance halls, attics, lofts, escape routes, etc. if they are not located inside technical compartments under the responsibility of each individual building and only accessible to the user (for the features of the technical compartments, see the technical standards in force);
- type B open chamber boilers must not be installed in places where commercial, artisan or industrial activities take place, which use products that may develop volatile vapours or substances (e.g. acid vapours, glues, paints, solvents, combustibles, etc.), as well as dusts (e.g. dust deriving from the working of wood, coal fines, cement, etc.), which may be harmful for the components of the appliance and jeopardise operation;
- they must also be installed in rooms where the temperature cannot fall below 0°C and must not be exposed to weathering.

Attention: wall mounting of the boiler must guarantee stable and efficient support for the generator.

The plugs (standard supply) are to be used only in

conjunction with the mounting brackets or fixing template to fix the appliance to the wall; they only ensure adequate support if inserted correctly (according to technical standards) in walls made of solid or semi-hollow brick or block. In the case of walls made from hollow brick or block, partitions with limited static properties, or in any case walls other than those indicated, a static test must be carried out to ensure adequate support.

N.B.: the hex head screws supplied in the blister pack are to be used exclusively to fix the relative mounting bracket to the wall.

These boilers are used to heat water to below boiling temperature in atmospheric pressure.

They must be connected to a central heating system and hot water circuit suited to their performance and capacity.

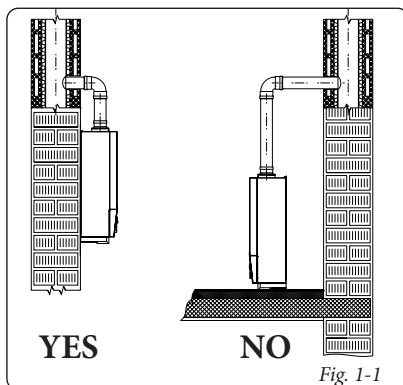
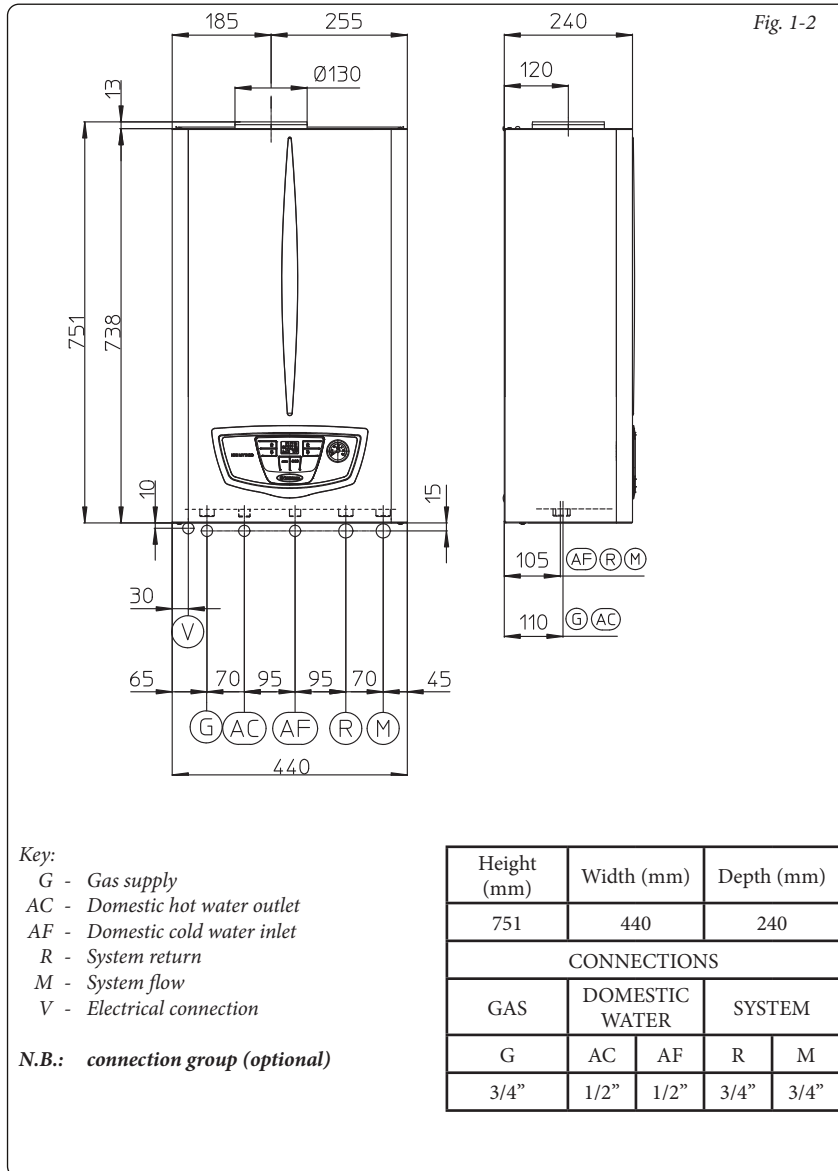

Fig. 1-1

1.2 MAIN DIMENSIONS.



1.3 CONNECTIONS (OPTIONAL).

Gas connection (Appliance category II_{2H3+}). Our boilers are designed to operate with methane gas (G20) or LPG. Supply pipes must be the same as or larger than the 3/4" G boiler fitting. Before connecting the gas line, carefully clean inside all the fuel feed system pipes to remove any residue that could impair boiler efficiency. Also make sure the gas corresponds to that for which the boiler is prepared (see boiler data-plate). If different, the appliance must be converted for operation with the other type of gas (see converting appliance for other gas types). The dynamic gas supply (methane or LPG) pressure must also be checked according to the type used in the boiler, which must comply with the regulations in force, as insufficient levels can reduce generator output and cause malfunctions. Ensure correct gas cock connection by following the mounting instructions illustrated in the figure. The gas supply pipe must be suitably dimensioned according to current regulations in order to guarantee correct gas flow to the burner even in conditions of maximum generator output and to guarantee appliance efficiency (technical specifications). The coupling system must conform to standards.

Fuel gas quality. The appliance has been designed to operate with combustible gas free of impurities; otherwise it is advisable to fit special filters upstream of the appliance to restore the purity of the fuel.

Storage tanks (in case of supply from LPG depot).

- New LPG storage tanks may contain residual inert gases (nitrogen) that degrade the mixture delivered to the appliance causing functioning anomalies.
- Due to the composition of the LPG mixture, layering of the mixture components may occur during the period of storage in the tanks. This can cause a variation in the heating power of the mixture delivered to the appliance, with subsequent change in its performance.

INSTALLER

USER

MAINTENANCE TECHNICIAN

Hydraulic connection.

Attention: in order not to void the heat primary exchanger warranty, before making the boiler connections, carefully clean the heating system (pipes, radiators, etc.) with special pickling or de-scaling products to remove any deposits that could compromise correct boiler operation.

A chemical treatment of the thermal system water is required, in compliance with the technical standards in force, in order to protect the system and the appliance from deposits (e.g., limescale), slurry or other hazardous deposits.

Water connections must be made in a rational way using the couplings on the boiler template. The boiler safety valve outlet must be connected to an appropriate drain. Otherwise, the manufacturer declines any responsibility in case of flooding if the drain valve cuts in.

Attention: the manufacturer declines all liability in the event of damage caused by the installation of an automatic filling system.

In order to meet the system requirements established by the regulations in terms of pollution of drinking water, we recommend installing the IMMERGAS anti-backflow kit to be used upstream of the cold water inlet connection of the boiler. It is also recommended that the heat transfer fluid (e.g. water + glycol) entered in the primary circuit of the boiler (heating circuit), complies with the local regulations in force.

Attention: to preserve the duration of appliance efficiency features, in the presence of water whose features can lead to the deposit of lime scale, installation of the "polyphosphate dispenser" kit is recommended.

Electrical connection. The Nike Mythos 24 2E boiler has an IPX4D protection rating for the entire appliance. Electrical safety of the appliance is reached only when it is correctly connected to an efficient earthing system as specified by current safety standards.

Attention: the manufacturer declines any responsibility for damage or physical injury caused by failure to connect the boiler to an efficient earth system or failure to comply with the reference standards.

Also ensure that the electrical installation corresponds to maximum absorbed power specifications as shown on the boiler data-plate. Boilers are supplied complete with an "X" type power cable without plug. The power supply cable must be connected to a 230V $\pm 10\%$ / 50Hz mains supply respecting L-N polarity and earth connection; , this network must also have a multi-pole circuit breaker with class III over-voltage category.

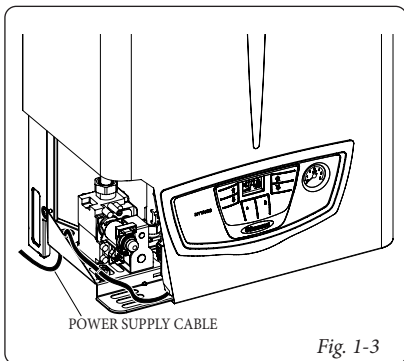

Fig. 1-3

When replacing the power supply cable, contact a qualified company (e.g. the Immergas Authorised After-Sales Technical Assistance Service). The power cable must be laid as shown (Fig. 1-3). In the event of mains fuse replacement on the P.C.B., use a 2A quick-blow fuse. For the main power supply to the appliance, never use adapters, multiple sockets or extension leads.

1.4 REMOTE CONTROLS AND ROOM CHRONO-THERMOSTATS (OPTIONAL).

The boiler is prepared for the application of room chrono-thermostats or remote controls, which are available as optional kits. (Fig. 1-4)

All Immergas chrono-thermostats are connected with 2 wires only. Carefully read the user and assembly instructions contained in the accessory kit.

- On/Off digital chrono-thermostat. The chrono-thermostat allows:
 - set two room temperature value: one for daytime (comfort temperature) and one for nighttime (lower temperature);
 - set a weekly programme with four daily switch on and switch off times;
 - select the required operating mode from the various possible alternatives:
 - manual mode (with adjustable temperature);
 - automatic mode (with set programme);
 - forced automatic mode (momentarily changing the temperature of the automatic programme).

The chrono-thermostat is powered by two 1.5V LR 6 type alkaline batteries.

- Comando Amico Remoto Remote Control Device ^{v2} (CAR^{v2}) with climate chrono-thermostat function. In addition to the functions described in the previous point, the CAR^{v2} panel enables the user to control all the important information regarding operation of the appliance and the heating system with the opportunity to easily intervene on the previously set parameters, without having to go to where the appliance is installed. The panel is provided with self-diagnosis to display any boiler functioning anomalies. The climate chrono-thermostat incorporated into the remote panel enables the system flow temperature to be adjusted to the actual needs of the room being heated, in order to obtain the desired room temperature with extreme precision and therefore with evident saving in running costs. The chrono-thermostat is fed directly by the boiler by means of the same 2 wires used for the transmission of data between boiler and chrono-thermostat.

CAR^{v2} or chrono-thermostat On/Off electric connection (Optional). *The operations described below must be performed after having removed the voltage from the appliance.* Any On/Off room chrono-thermostat must be connected to clamps 40 and 41 eliminating jumper X40 (Fig. 3-2). Make sure that the On/Off thermostat contact is of the "clean" type, i.e. independent of the mains supply, otherwise the P.C.B. would be damaged. Any CAR^{v2} must be connected to clamps 40 and 41 eliminating jumper X40 on the circuit board, paying attention not to invert the polarity in the connections (Fig. 3-2). Connection with the wrong polarity prevents functioning, but without damaging the CAR^{v2}. The boiler can only be connected to one remote control.

Important: if the CAR^{v2} remote control is used, arrange two separate lines in compliance with current regulations regarding electrical systems. No boiler pipes must ever be used to earth the electric system or telephone lines. Ensure elimination of this risk before making the boiler electrical connections.

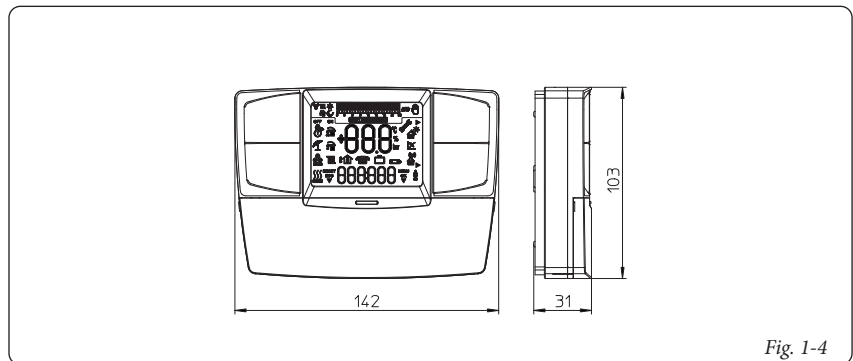

Fig. 1-4

1.5 VENTILATION OF THE ROOMS.

In the room in which the boiler is installed it is necessary that at least as much air flows as that requested for by normal combustion of the gas and ventilation of the room. Natural air flow must take place directly through:

- permanent openings in the walls of the room to be ventilated that lead towards the outside;
- ventilation pipes, individual or branched type.

The air used for ventilation must be withdrawn directly from outside, in an area away from sources of pollution. Natural air flow is also allowed indirectly by air intake from adjoining rooms. For further information relative to ventilation of the rooms follow that indicated by the standards in force and the following modifications and integrations.

Evacuation of foul air. In the rooms where the gas appliances are installed it may also be necessary, as well as the intake of combustion agent air, to evacuate foul air, with consequent intake of a further equal amount of clean air. This must be realised respecting the provisions of the technical regulations in force.

1.6 FLUE DUCTS.

The gas appliances with attachment for the flue gas discharge pipe must have direct connection to chimneys or safely efficient flues.

The combustion products can be discharged directly outside only if these are missing, as long as the standard regulations for the flue terminal are respected as well as the existing laws.

Connection to chimneys or flues. The connection of the appliances to a chimney or flue takes place by means of flue ducts.

In the event of fittings with pre-existing flues, these must be perfectly clean because the detachment of any waste from the walls during functioning, could block the passage of flue gases, thus causing extremely dangerous situations for the user.

The flue ducts must be connected to the chimney or flue in the same room in which the appliance is installed or, at most, in the adjoining room and must comply with the requirements indicated by the regulation.

1.7 FLUES/CHIMNEYS.

For the appliances with natural draught individual chimneys and branched flues can be used.

Individual chimneys. The individual flues must be dimensioned with respect to the standard in force.

Branched flues. In buildings with lots of floors, branched flues can be used for the natural draught evacuation of combustion products. New flues must be designed following the calculation method and provisions of the regulation.

Chimney caps. A chimney cap is a device crowning an individual chimney or collective branched flue. The device facilitates the dispersion of combustion products, even with bad weather, and prevents the deposit of foreign bodies.

It must meet the standard requirements

The outlet quota, corresponding to the top of the chimney/flue, independently of any caps, must be out of the "backflow area", in order to prevent the formation of counter-pressures that impede the free discharge of the combustion products into the atmosphere. It is therefore necessary to use the minimum heights indicated in the figures stated in the regulation, depending on the slope of the roof.

Direct exhaust outside. The natural draught appliances, envisioned to be connected to a chimney or a flue, can discharge the combustion products directly to the outside, through a pipe passing through the perimeter walls of the building. In this case discharge takes place through an exhaust flue, which is connected to a draught terminal at the outside.

Exhaust flue. The exhaust flue must be in compliance with the same requisites listed for the flue ducts, with further provisions stated in the regulation in force.

Positioning the exhaust terminals. The exhaust terminals must:

- be installed on external perimeter walls of the building;
- be positioned according to the minimum distances specified in current technical standards.

Fume exhaust of forced draught appliances in closed open-top environments. In spaces closed on all sides with open tops (ventilation pits, courtyards etc.), direct flue gas exhaust is allowed for natural or forced draught gas appliances with a heating power range from 4 to 35 kW, provided the conditions as per the current technical standards are respected.

Important: it is prohibited to put the fumes exhaust control device out of order voluntarily. Every piece of this device must be replaced using original spare parts if they have deteriorated. In the case of repeated interventions of the fumes exhaust control device, check the fumes exhaust flue and the ventilation of the room in which the boiler is located.

1.8 SYSTEM FILLING.

Once the boiler is connected, proceed with system filling via the filling valve (Fig. 2-2). Filling is performed at low speed to ensure release of air bubbles in the water via the boiler and heating system vents. The boiler has a built-in automatic venting valve on the circulator. Open the radiator vent valves. Close radiator vent valves when only water escapes from them. Close the filling valve when the boiler manometer indicates approx. 1.2 bar.

N.B.: during these operations start up the circulation pump at intervals, acting on the main switch positioned on the control panel. *Vent the circulation pump by loosening the front cap and keeping the motor running.*

Tighten the cap after the operation.

1.9 GAS SYSTEM START-UP.

To start up the system, make reference to the Standard. In particular, for new gas systems:

- open windows and doors;
- avoid presence of sparks or open flames;
- bleed all air from the pipelines;
- check that the internal system is properly sealed according to specifications.

1.10 BOILER COMMISSIONING (IGNITION).

To commission the boiler (the operations listed below must only be performed by qualified personnel and in the presence of staff only):

- check that the internal system is properly sealed according to the regulations in force;
- make sure that the type of gas used corresponds to boiler settings;
- check that there are no external factors that may cause the formation of fuel pockets;
- switch the boiler on and check correct ignition;
- make sure that the gas flow rate and relevant pressure values comply with those given in the manual (par. 3.16);
- check the correct ventilation of the rooms;
- check the existing draught during normal functioning of the appliance, e.g. a draught gauge positioned at the exit of the appliance combustion products;
- check that there is no backflow of combustion products into the room, even during functioning of fans;
- ensure that the safety device intervenes in the event of gas supply failure and check the relative intervention time;
- check activation of the main switch located upstream of the boiler.

The boiler must not be started up even if only one of the checks should be negative.

1.11 CIRCULATION PUMP.

The Nike Mythos 24 2E series boilers are supplied with a built-in circulation pump with three-position electric speed control. The boiler does not operate correctly with the circulation pump on first speed. To ensure optimal boiler operation, in the case of new systems (single pipe and module) it is recommended to use the pump at maximum speed. The circulation pump is already fitted with a capacitor.

Pump release. If, after a prolonged period of inactivity, the circulation pump is blocked, unscrew the front cap and turn the motor shaft using a screwdriver. Take great care during this operation to avoid damage to the motor.

By-pass regulation (part. 16 Fig. 1-6). If necessary, the by-pass can be adjusted according to system requirements from a minimum (by-pass excluded) to a maximum (by-pass inserted) represented by the graph (Fig. 1-5). Make the adjustment using a flat head screwdriver, turn clockwise and insert the by-pass; by turning it anti-clockwise it is excluded.

1.12 KITS AVAILABLE ON REQUEST.

- Connection unit kit (on request). The kit includes pipes, fittings and cocks (including gas cock), to carry out all connections to the boiler system
- System shut off valves kit. The boiler is designed for installation of system interception cocks to be placed on flow and return pipes of the connection assembly. This kit is particularly useful for maintenance as it allows to drain just the boiler without having to empty the entire system.
- Polyphosphate dispenser kit. The polyphosphate dispenser reduces the formation of lime-scale and preserves the original heat exchange and domestic hot water production conditions. The boiler is prepared for application of the polyphosphate dispenser kit.

The above-mentioned kits are supplied complete with instructions for assembly and use.

Head available to the system.

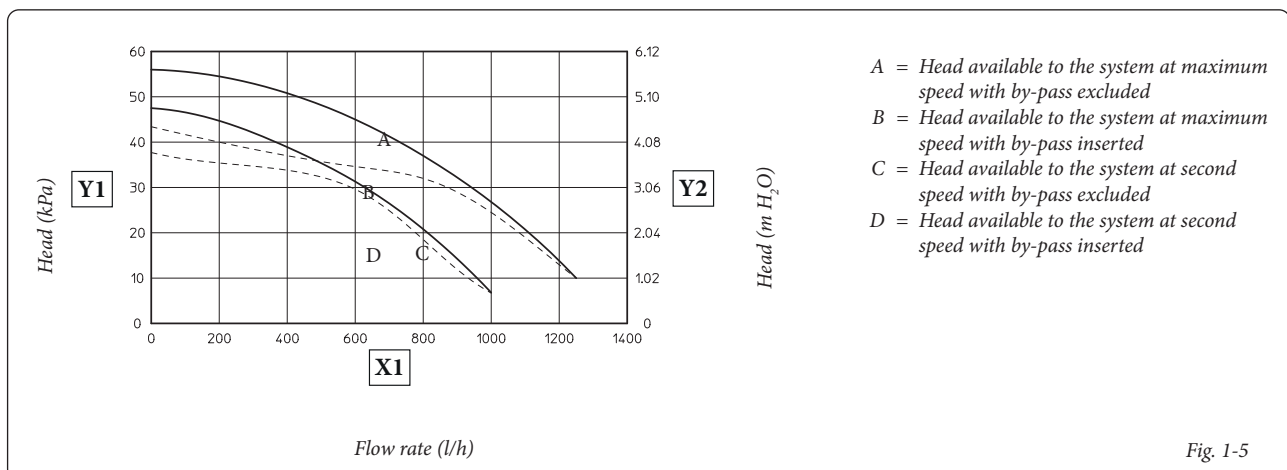
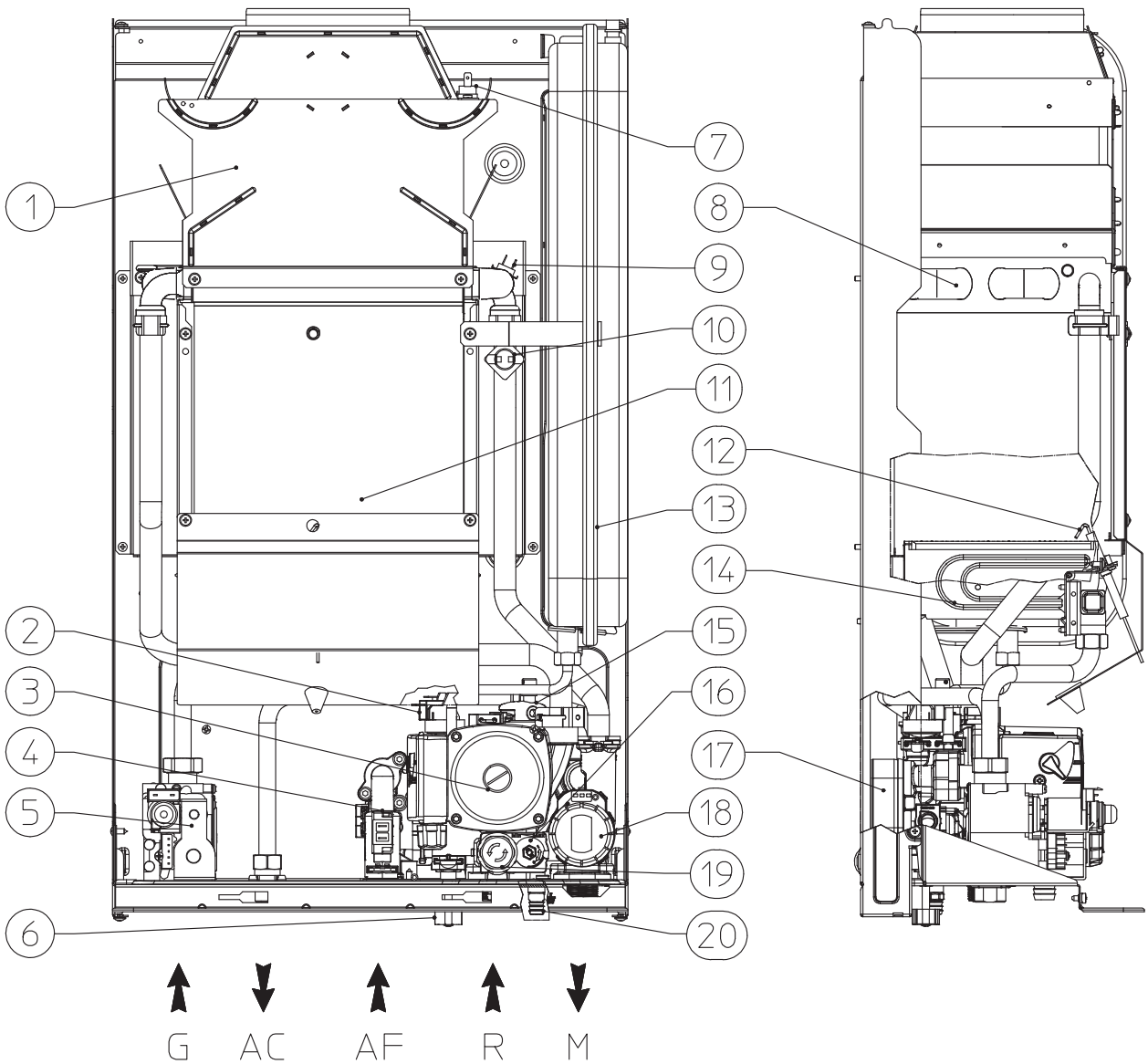

Fig. 1-5

1.13 BOILER COMPONENTS.



Key:

- 1 - Fumes hood
- 2 - System pressure switch
- 3 - Boiler circulator pump
- 4 - Domestic hot water flow switch
- 5 - Gas valve
- 6 - System filling valve
- 7 - Flue safety thermostat
- 8 - Primary heat exchanger
- 9 - Delivery probe
- 10 - Safety thermostat

- 11 - Combustion chamber
- 12 - Ignition and detection electrodes
- 13 - System expansion vessel
- 14 - Burner
- 15 - Vent valve
- 16 - By-pass
- 17 - DHW heat exchanger
- 18 - Three-way valve (motorised)
- 19 - 3 bar safety valve
- 20 - System draining valve

N.B.: connection group (optional)

INSTALLER

USER

MAINTENANCE TECHNICIAN

Fig. 1- 6

2 INSTRUCTIONS FOR USE AND MAINTENANCE

2.1 CLEANING AND MAINTENANCE.

Attention: the heating systems must undergo periodical maintenance (regarding this, see the section dedicated to the maintenance engineer, relating to “yearly appliance check and maintenance”) and regular energy efficiency checks in compliance with national, regional or local provisions in force.

This ensures that the optimal safety, performance and operation characteristics of the boiler remain unchanged over time.

We recommend stipulating a yearly cleaning and maintenance contract with your zone technician.

2.2 VENTILATION OF THE ROOMS.

In the room in which the boiler is installed it is necessary that at least as much air flows as that requested for by normal combustion of the gas and ventilation of the room. The provisions relative to ventilation, the flue ducts, chimneys and caps are stated in Par. 1.5, 1.6 and 1.7. If in doubt regarding correct ventilation, refer to professional, qualified staff.

2.3 GENERAL WARNINGS.

Never expose the wall-mounted boiler to direct vapours from a cooking surface.

Use of the boiler by unskilled persons or children is strictly prohibited.

If temporary shutdown of the boiler is required, proceed as follows:

- drain the heating system if anti-freeze is not used;
- shut-off all electrical, water and gas supplies.

2.4 CONTROL PANEL.

In the case of work or maintenance to structures located in the vicinity of ducting or devices for flue extraction and relative accessories, switch off the appliance and on completion of operations ensure that a qualified technician checks efficiency of the ducting or other devices. Never clean the appliance or connected parts with easily flammable substances.

Never leave containers or flammable substances in the same environment as the appliance.

It is prohibited and dangerous to obstruct the air intake, even partially, for the ventilation of the room in which the boiler is installed.

Due to the danger, functioning is also prohibited in the same room as suction devices, chimneys or similar at the same time as the boiler unless there are additional openings dimensioned in a way to satisfy the further necessity for air. For the dimensioning of these additional openings, refer to qualified technical staff. In particular, an open fire must have its own air supply.

On the contrary, the boiler cannot be installed in the same room.

• **Attenzione:** the use of components involving use of electrical power requires some fundamental rules to be observed:

- do not touch the appliance with wet or moist parts of the body; do not touch when barefoot;
- never pull electrical cables or leave the appliance exposed to weathering (rain, sunlight, etc.);
- the appliance power cable must not be replaced by the user;
- in the event of damage to the cable, switch off the appliance and contact exclusively qualified staff for replacement;
- if the appliance is not to be used for a certain period, disconnect the main power switch.

N.B.: the temperatures indicated by the display have a tolerance of +/- 3°C due to environmental conditions that cannot be attributed to the boiler.

At the end of its service life, the appliance must not be disposed of like normal household waste nor abandoned in the environment, but must be removed by a professionally authorised company. Contact the manufacturer for disposal instructions.

Fig. 2-1

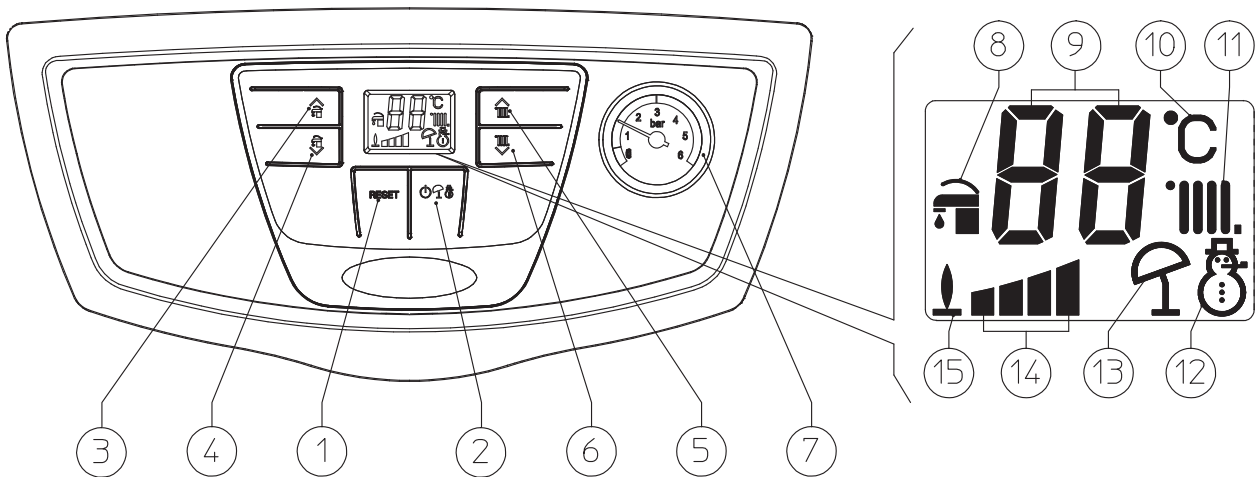

Key:

- Reset button
- Stand-by/summer/winter button
- Button (+) to increase the domestic hot water temperature
- Button (-) to reduce the domestic hot water temperature

- Button(+) to increase the system water temperature
- Button (-) to reduce the system water temperature
- Boiler manometer
- Domestic hot water functioning
- Temperatures and error code display
- Unit of measurement

- Central heating functioning
- Winter
- Summer
- Power distributed
- Flame presence

Boiler ignition. Before ignition make sure the heating system is filled with water and that the manometer (7) indicates a pressure of $1 \div 1.2$ bar.

- Open the gas cock upstream from the boiler.
- Press key (2) and set the boiler on Summer (☀) or Winter (❄).

N.B.: the button (2) must be pressed and held for the time required to switch from the Stand-by (---), Summer (☀) or Winter (❄) function.

Attention: after each switch the button must in any case be released to switch to the next function.

When in summer position (☀) the domestic hot water temperature is adjusted with the buttons (3-4).

When the winter position is selected (❄) the system water temperature is adjusted with the buttons (5-6), whilst the domestic hot water temperature is adjusted using the buttons (3-4), by pressing (+) to increase and (-) to reduce the temperature.

From this moment the boiler functions automatically. With no demand for heat (heating or domestic hot water production) the boiler goes to "standby" function, equivalent to the boiler being powered without presence of flame. Each time the boiler ignites, the relative flame present symbol is displayed (15).

2.5 TROUBLESHOOTING.

In the event of an anomaly the boiler backlight turns from green to red on and the relative error codes, listed in the table, flash on the display.

Anomaly signalled	code error
No ignition block	01
Over-heating (safety) thermostat block	02
Flue safety thermostat anomaly	03
Electro-mechanical contacts	04
Flow probe anomaly	05
Insufficient system pressure	10
Parasite flame	20
Insufficient circulation	27
Loss of remote control communication	31

Ignition block. The boiler ignites automatically with each request for room heating or hot water production. If the burner does not ignite within 10 seconds, the boiler goes into "ignition block" (code 01). To eliminate "ignition block" the Reset button (1) must be pressed. On commissioning or after extended appliance downtime, it may be necessary to eliminate the "ignition block". If this phenomenon occurs frequently, contact an authorised company (e.g. Immergas After-Sales Technical Assistance Service).

Overheating thermostat block. During normal operation, if a fault causes excessive overheating internally, the boiler goes into overheating block (code 02). After allowing to cool, eliminate the "overheating block" by pressing the Reset key (1). If this phenomenon occurs frequently, contact an authorised company (e.g. Immergas After-Sales Technical Assistance Service).

Flue safety thermostat anomaly. If the flue evacuation pipe does not work properly during functioning, the flue thermostat intervenes by blocking the boiler (code 03). The boiler will automatically restart after 30 minutes if normal conditions resume without having to be reset. If the flue thermostat intervenes 3 times in less than two hours (code 03), it is necessary to reset the boiler manually by pressing the Reset button (1). If this anomaly persists, contact a qualified technician for assistance (e.g. Immergas After-Sales Service).

Electro-mechanical contacts This occurs when the safety thermostat, the fume pressure switch or the system pressure switch do not work properly (code 04). The boiler does not start; try resetting the boiler. If the anomaly persists contact an authorised company (e.g. Immergas After-Sales Technical Assistance Service).

Delivery probe anomaly If the board detects an anomaly on the flow probe (code 05), the boiler will not start; contact an authorised company (e.g. Immergas After-Sales Technical Assistance Service).

Insufficient system pressure. Water pressure inside the heating system (code 10), sufficient to guarantee the correct functioning of the boiler, is not detected. Check that the system pressure is between $1 \div 1.2$ bar.

Parasite flame. This occurs in the event of a leak on the detection circuit or anomaly in the flame control unit (code 20); try to reset the boiler. If the anomaly persists contact an authorised company (e.g. Immergas After-Sales Technical Assistance Service).

Insufficient water circulation. This occurs if the boiler overheats due to insufficient water circulating in the primary circuit (code 27); the causes can be:

- low system circulation; check that no shut-off devices are closed on the heating circuit and that the system is free of air (deaerated);
- pump blocked; free the pump.

If this phenomenon occurs frequently, contact an authorised company (e.g. Immergas After-Sales Technical Assistance Service).

Loss of Remote Control communication. This occurs 1 minute after loss of communication between the boiler and the remote control (code 31). To reset the error code, remove and re-apply voltage to the boiler. If this phenomenon occurs frequently, contact an authorised company (e.g. Immergas After-Sales Technical Assistance Service).

Boiler shutdown. Press the button (2 Fig. 2-1) (⏻) until the symbol (↔) appears on the display.

N.B.: in these conditions the boiler is still powered.

Disconnect the external omnipolar boiler switch and close the gas cock upstream of the appliance. Never leave the boiler switched on if left unused for prolonged periods.

2.6 RESTORING CENTRAL HEATING SYSTEM PRESSURE.

Periodically check the system water pressure. The boiler manometer should read a pressure between 1 and 1.2 bar.

If the pressure is below 1 bar (with the circuit cool) restore normal pressure via the filling cock located in the lower part of the boiler (Fig. 2-2).

N.B.: close the filling cock after the operation. If pressure values reach around 3 bar the safety valve may be activated.

In this case contact a professional technician for assistance.

In the event of frequent pressure drops, contact qualified staff for assistance to eliminate the possible system leakage.

2.7 SYSTEM DRAINING.

To drain the boiler, use the special draining valve (Fig. 2-2).

Before draining, ensure that the filling valve is closed.

2.8 ANTI-FREEZE PROTECTION.

The boiler features an antifreeze function that automatically ignites the burner when the temperature falls below 4°C and stops once 42°C have been exceeded. The antifreeze function is ensured if the appliance is in perfect working order in all its parts, if it is not “blocked”, and if it is not in “off” mode. To avoid keeping the system switched on in case of a prolonged absence, the system must be drained completely or antifreeze substances must be added to the heating system water. In both cases the boiler domestic hot water circuit must be drained. In systems that are drained frequently, filling must be carried out with suitably treated water to eliminate hardness that can cause lime-scale.

2.9 CASE CLEANING.

Use damp cloths and neutral detergent to clean the boiler casing. Never use abrasive or powder detergents.

2.10 DECOMMISSIONING.

In the event of permanent shutdown of the boiler, contact professional staff for the procedures and ensure that the electrical, water and gas supply lines are shut off and disconnected.

Bottom view.

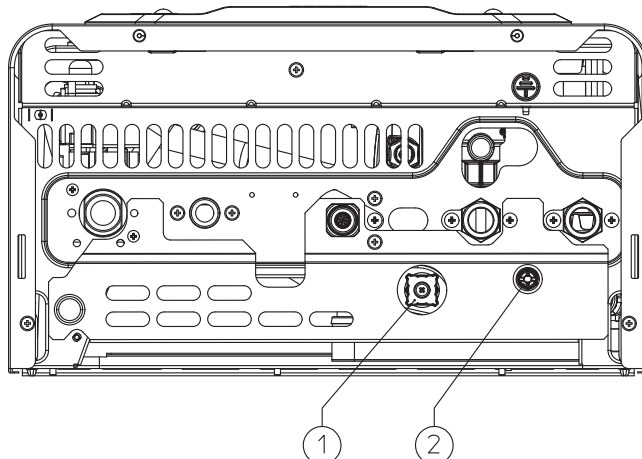

Key:
 1 - Filling valve
 2 - Draining valve

Fig. 2-2

3 BOILER COMMISSIONING (INITIAL CHECK)

To commission the boiler:

- make sure that the type of gas used corresponds to boiler settings;
- check connection to a 230V-50Hz power mains, correct L-N polarity and the earthing connection;
- make sure the central heating system is filled with water and that the manometer indicates a pressure of 1÷1.2 bar.
- switch the boiler on and check correct ignition;
- make sure the gas maximum, intermediate and minimum flow rate and pressure values correspond to those given in the handbook par. 3.16;

- check activation of the safety device in the event of no gas, as well as the relative activation time;
- check activation of the main switch located upstream of the boiler;
- check the existing draught during normal functioning of the appliance, e.g. a draught gauge positioned at the exit of the appliance combustion products;
- check that there is no backflow of combustion products into the room, even during functioning of fans;
- ensure activation of all adjustment devices;
- seal the gas flow rate regulation devices (if settings are modified);
- check the production of domestic hot water;

- check sealing efficiency of water circuits;
 - check ventilation and/or aeration of the installation room where required.
- If even only a single safety check offers a negative result, do not commission the system.

3.1 HYDRAULIC DIAGRAM.

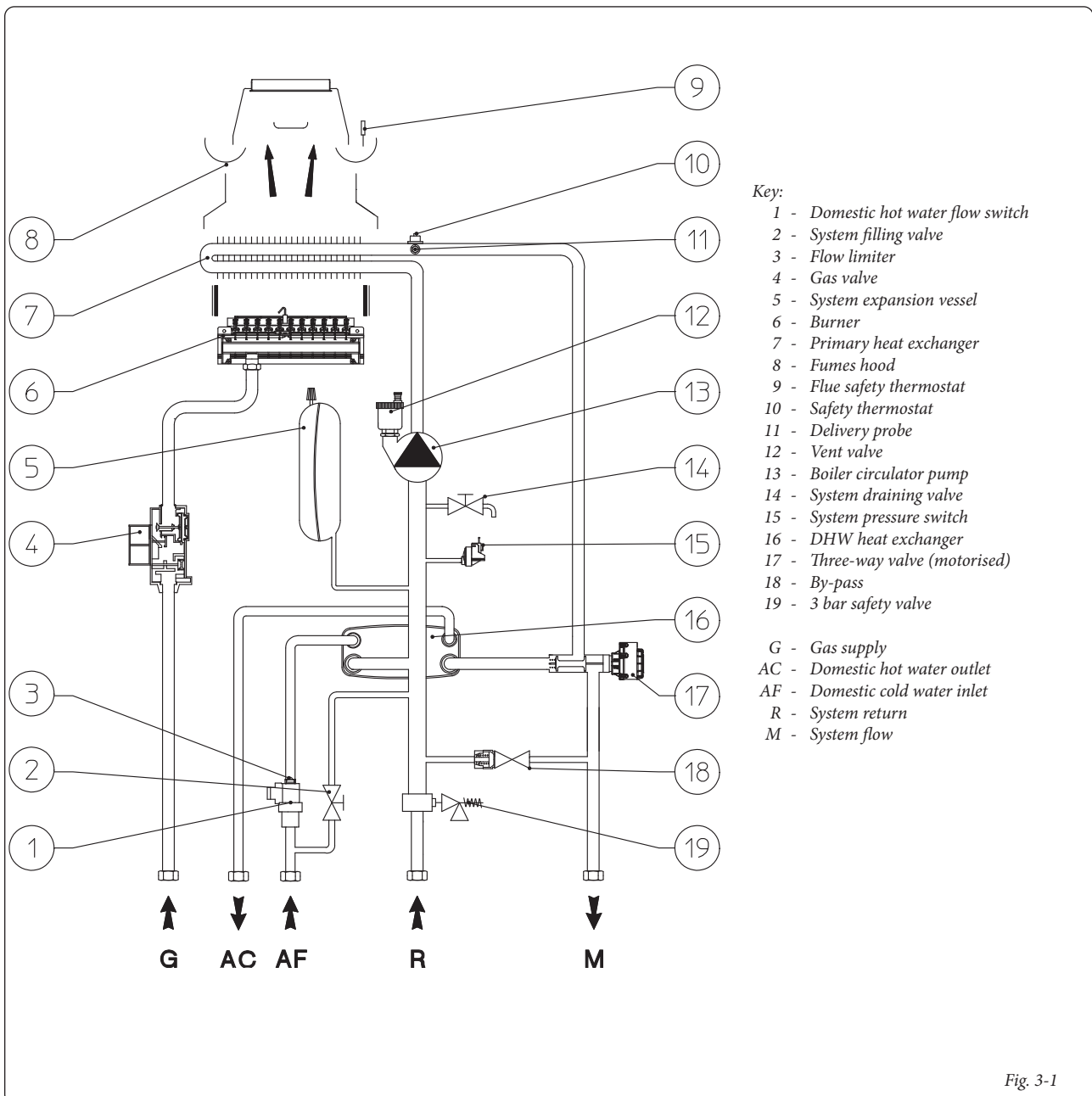

Fig. 3-1

3.2 WIRING DIAGRAM.

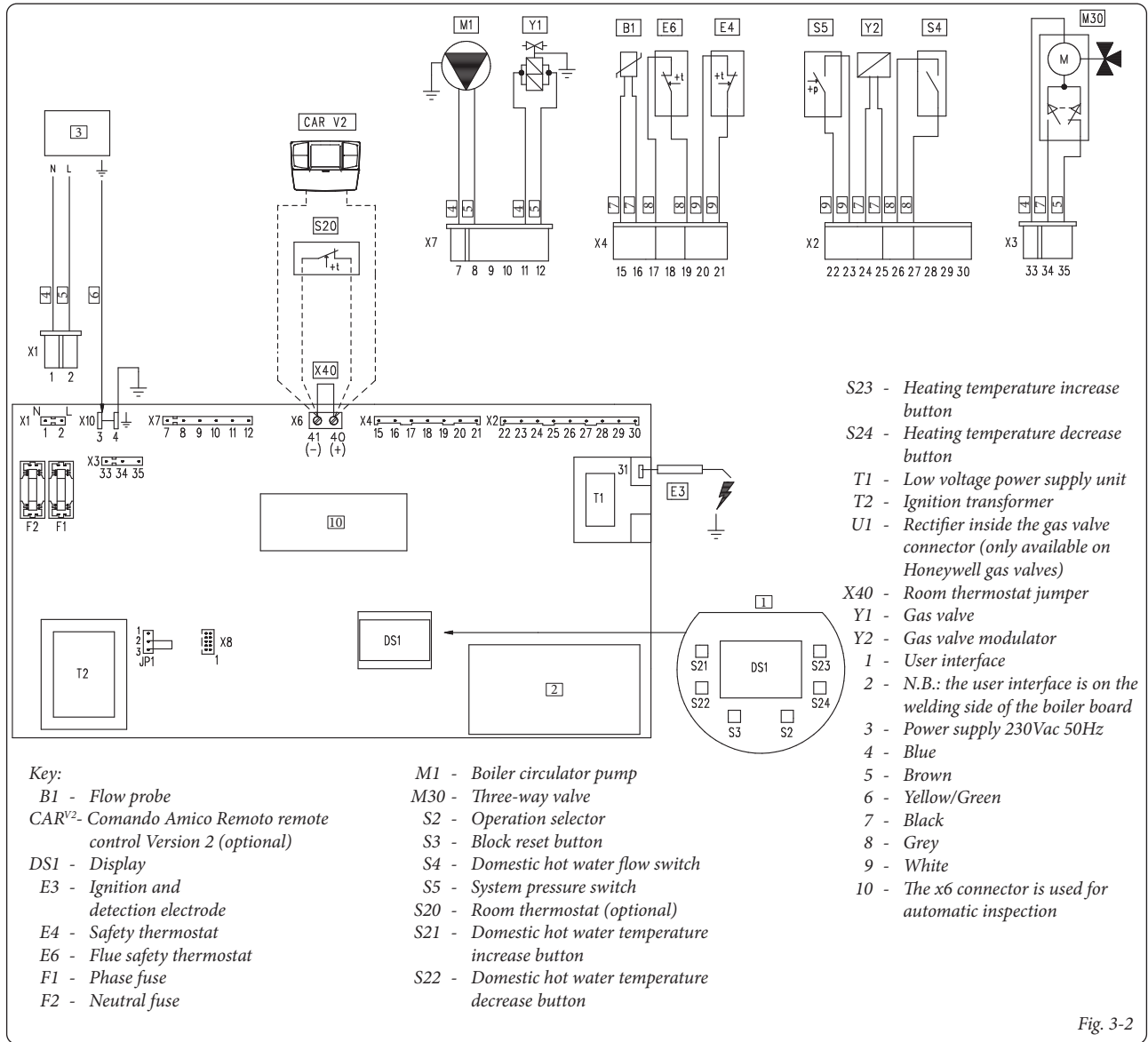

Fig. 3-2

Comando Amico Remoto^{V2}: the boiler is set-up for the application of the Comando Amico Remoto remote control ^{V2} (CAR^{V2}) which must be connected to clamps 40 and 41, by observing polarity and eliminating jumper X40.

Room thermostat: the boiler is set-up for the application of the Room Thermostat (S20) which must be connected to clamps 40 and 41 and by eliminating jumper X40.

The connector X6 is for connection to a personal computer.

3.3 TROUBLESHOOTING.

N.B.: maintenance interventions must be carried out by an authorised company (e.g. Immergas After-Sales Technical Assistance Service).

- Smell of gas. Caused by leakage from gas circuit pipelines. Check sealing efficiency of gas intake circuit.
- Irregular combustion (red or yellow flame). When the burner is dirty or the boiler lamellar pack is blocked. Clean the burner or the boiler lamellar pack.

- Frequent interventions of the over heating safety thermostat. It can depend on the lack of water in the boiler, little water circulation in the system or blocked pump. Check on the manometer that the system pressure is within established limits. Check that the radiator valves are not closed and also the functionality of the pump.
- The boiler produces condensate. This can be caused by obstructions of the chimney or flues with height or section not proportioned to the boiler. It can also be determined by functioning at boiler temperatures that are excessively low. In this case, make the boiler run at higher temperatures.
- Frequent interventions of the flue safety thermostat. This can be caused by obstructions in the fumes circuit. Check the flue. The flue may be obstructed or by height or section not suitable for the boiler. Ventilation may be insufficient (see room ventilation point).
- Presence of air in the system. Check opening of the special air vent valve cap (Fig. 1-6). Make sure the system pressure and expansion vessel pressure values are within the set limits; the

pressure value for the expansion vessel must be 1.0 bar, and system pressure must be between 1 and 1.2 bar.

- Ignition block and Chimney block. (See par. 2.5 and 1.3 (electric connection).

3.4 CONVERTING THE BOILER TO OTHER TYPES OF GAS.

If the boiler has to be converted to a different gas type to that specified on the data plate, request the relative conversion kit for quick and easy conversion.

The gas conversion operation must be carried out by an authorised company (e.g. Immergas After-Sales Technical Assistance Service).

To convert to another type of gas the following operations are required:

- disconnect the appliance;
- replace the main burner injectors, making sure to insert the special seal rings supplied in the kit, between the gas manifold and the injectors;
- re-power the appliance;
- select, using the boiler key, the gas parameter type (P1) and select (nG) in the case of methane supply or (LG) in the case of LPG supply;
- adjust the boiler nominal heat output;
- adjust the boiler nominal heat output in domestic hot water phase;
- adjust the boiler nominal heat output in heating phase;
- adjust (eventually) the maximum heating power;
- seal the gas flow rate regulation devices (if settings are modified);
- after completing the conversion, apply the sticker, contained in the conversion kit, near the data-plate. Using an indelible marker pen, cancel the data relative to the old type of gas.

These adjustments must be made with reference to the type of gas used, following that given in the table (Par. 3.16).

3.5 CHECKS FOLLOWING CONVERSION TO ANOTHER TYPE OF GAS.

After making sure that conversion was carried out with a nozzle of suitable diameter for the type of gas used and the settings are made at the correct pressure, check that:

- there is no flame in the combustion chamber;
- the burner flame is not too high or low and that it is stable (does not detach from burner);
- the pressure testers used for calibration are perfectly closed and there are no leaks from the gas circuit.

N.B.: all boiler adjustment operations must be carried out by an authorised company (e.g. Immergas After-Sales Assistance). Burner adjustment must be carried out using a differential "U" or digital type pressure gauge connected to the gas valve outlet pressure point (part. 4 Fig. 3-3), keeping to the pressure value given in the table (Par. 3.16) according to the type of gas for which the boiler is prepared.

3.6 POSSIBLE ADJUSTMENTS.

- Adjustment of boiler nominal thermal heat output.
 - Press the domestic hot water adjustment button (+) (3 Fig. 2-1) up to the maximum operating temperature.
 - Open the domestic hot water cock in order to prevent modulation intervention.
 - With the brass nut (3 Fig. 3-3) adjust the boiler nominal output, observing the maximum pressure values stated in the tables (Par. 3.16) depending on the type of gas.
 - By turning in a clockwise direction the heating potential increases and in an anti-clockwise direction it decreases.
- Adjust the boiler minimum heat output in the domestic hot water phase (Fig. 3-3).

N.B.: only proceed after having calibrated the nominal pressure.

Adjustment of the minimum thermal input is obtained by operating on the cross plastic screws (2) on the gas valve maintaining the brass nut blocked (3);

- disconnect the power supply to the modulating coil (just disconnect a faston); by turning the screw clockwise, the pressure increases, anti-clockwise it decreases. On completion of calibration, re-apply the power supply to the modulating coil. The pressure to which the boiler minimum power must be adjusted, must not be lower than that stated in the tables (Par. 3.16) depending on the type of gas.

N.B.: to adjust the gas valve, remove the plastic cap (6); after adjusting, refit the cap.

3.7 PROGRAMMING THE P.C.B.

The boiler is prepared for possible programming of several operation parameters. By modifying these parameters as described below, the boiler can be adapted according to specific needs.

To access the programming phase, proceed as follows (references Fig. 2-1):

- press buttons (1) and (2) for 15 about seconds until the programming mode is accessed on the display;
- using buttons (3) and (4), select the parameter to be changed indicated in the following table:

List of parameters	Description
P1	Gas type selection
P2	Special gas G110 selection (Not used on this model)
P3	Fixed or correlated domestic hot water set-point
P5	Minimum CH output
P6	Maximum CH output
P7	Central heating ignitions timer
P8	Central heating ramp timer
p9	Boiler type (fixed on mono-thermal)

- adjust the corresponding value consulting the table using keys (5) and (6);
- confirm the set value pressing the reset key (1) for approximately 5 seconds; pressing keys (3) + and (4) - at the same time to adjust the domestic hot water temperature, the operation is cancelled.

N.B.: after a period of time, without touching any keys, the operation cancels automatically.

Gas type selection. The setting of this function is used to adjust the boiler in order to function with LPG gas or Methane gas.

Gas type selection	
Range of values which can be set	Parameter
LG (LPG) o nG (Methane)	P1

Gas G110 - Industrial gas (Not used on this model). The setting of this function is used to adjust the boiler in order to function with gases from the first family.

Gas G110 - Industrial gas (first family gas)	
Range of values which can be set	Parameter
on - off (Standard setting)	P2

Fixed or correlated domestic hot water set-point. By setting the parameter P3 in **on** mode, burner disabling is correlated to the adjustment of the domestic hot water temperature. In **OFF** mode, the burner is switched off at maximum value.

Fixed or correlated domestic hot water set-point	
Range of values which can be set	Parameter
on correlated - off fixed (Standard settings)	P3

SIT 845 GAS Valve

Key:

- 1 - Coil
- 2 - Minimum power adjustment screw
- 3 - Maximum power adjustment nut
- 4 - Gas valve outlet pressure point
- 5 - Gas valve inlet pressure point
- 6 - Protection hood

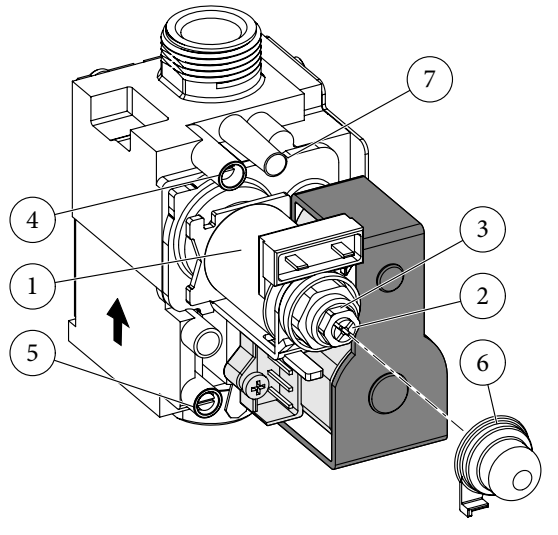

Fig. 3-3

Heating output. The boiler also has electronic modulation that adapts the boiler potentiality to the effective heating demand of the house. Then the boiler works normally in a variable gas pressure field between the minimum heating output and the maximum heating output depending on the system's heating load.

N.B.: the boiler is produced and calibrated in the central heating phase at nominal output. Approximately 10 minutes are needed to reach the nominal heat output changeable using parameter (P6).

N.B.: the selection of the "Minimum heating output" and "Maximum heating output" parameters, in presence of a heating request, allows boiler ignition and power supply of the modulator with current equal to the value of the respective set value.

Minimum CH output	
Range of values which can be set	Parameter
from 0 % I _{max} . to 63 % I _{max} .	P5

Maximum CH output	
Range of values which can be set	Parameter
from 0 % I _{max} . to 99 % I _{max} . (Standard setting)	P6

Timer setting. The boiler has an electronic timing device that prevents the burner from igniting too often in the heating phase. The boiler is supplied as per standard with a timer adjusted at 3 minutes.

Central heating ignitions timer	
Range of values which can be set	Parameter
from 1 to 10 3 = 3 minutes (Standard setting) 1 = 30 seconds	P7

Central heating ramp timing. The boiler performs an ignition ramp of about 10 minutes to arrive from minimum power to nominal heating power.

Central heating ramp timer	
Range of values which can be set	Parameter
from 1 to 10 10 = 10 minutes (Standard setting) 1 = 30 seconds	P8

Boiler type. The parameter indicates the operation of the boiler type in use and is set as standard, non modifiable, on instant monothermal boiler (0).

N.B.: the jumper (JP1) on the circuit board (Fig. 3-2) remains fixed on position 2-3 for monothermal boiler.

Boiler type	
Fixed position	Parameter
0 = monothermal boiler (instantaneous)	P9

3.8 AUTOMATIC SLOW IGNITION FUNCTION WITH TIMED RAMP DELIVERY.

In the ignition phase the P.C.B. carries out an increasing gas delivery ramp (with pressure values that depend on the type of gas selected) with preset duration. This prevents every calibration or precision adjustment of the boiler ignition phase in any conditions of use.

3.9 "CHIMNEY SWEEP FUNCTION".

When activated, this function forces the boiler at max. output for 15 minutes.

In this state all adjustments are excluded and only the temperature safety thermostat and the limit thermostat remain active. To activate the chimney sweep function, press the Reset key for at least 10 seconds. Its activation is indicated by the flashing symbols (8 and 11 Fig. 2-1). This function allows the technician to check

the combustion parameters. After the checks disable the function, switching the boiler off and then on again or simply by pressing the button (2 Fig. 2-1).

3.10 HEATING TIMER.

The boiler has an electronic timing device that prevents the burner from igniting too often in the heating phase. The boiler is supplied as per standard with a timer adjusted at 3 minutes. To adjust the timer values, follow instructions for parameter settings by selecting parameter (P7) and set it with one of the values indicated on the relative table.

3.11 PUMP ANTI-BLOCK FUNCTION.

In the "summer" functioning mode (☀) the boiler has a function that starts the pump at least once every 24 hours for 30 seconds in order to reduce the risk of the pump becoming blocked due to prolonged inactivity.

In the "winter" functioning mode (❄) the boiler has a function that makes the pump start at least once every 3 hours for 30 seconds.

3.12 RADIATORS ANTI-FREEZE FUNCTION.

If the system return water is below 4°C, the boiler starts up until reaching 42°C.

3.13 P.C.B. PERIODICAL SELF-CHECK.

During functioning in heating mode or with boiler in standby, the function activates every 18 hours after the last boiler check/power supply. In case of functioning in domestic hot water mode the self-check starts within 10 minutes after the end of the withdrawing in progress, for duration of approx. 10 seconds.

N.B.: during self-check, the boiler remains off, including signalling.

3.14 CASING REMOVAL.

To facilitate boiler maintenance the casing can be completely removed as follows (Fig. 3-4):

- remove the frame (1) holding the edges and pulling it towards you as indicated by the arrows;
- undo the 2 front screws (2) and the 2 lower screws (3) which fasten the casing (4);
- pull the casing (4) towards yourself and upwards at the same time in order to detach it from the upper hooks.

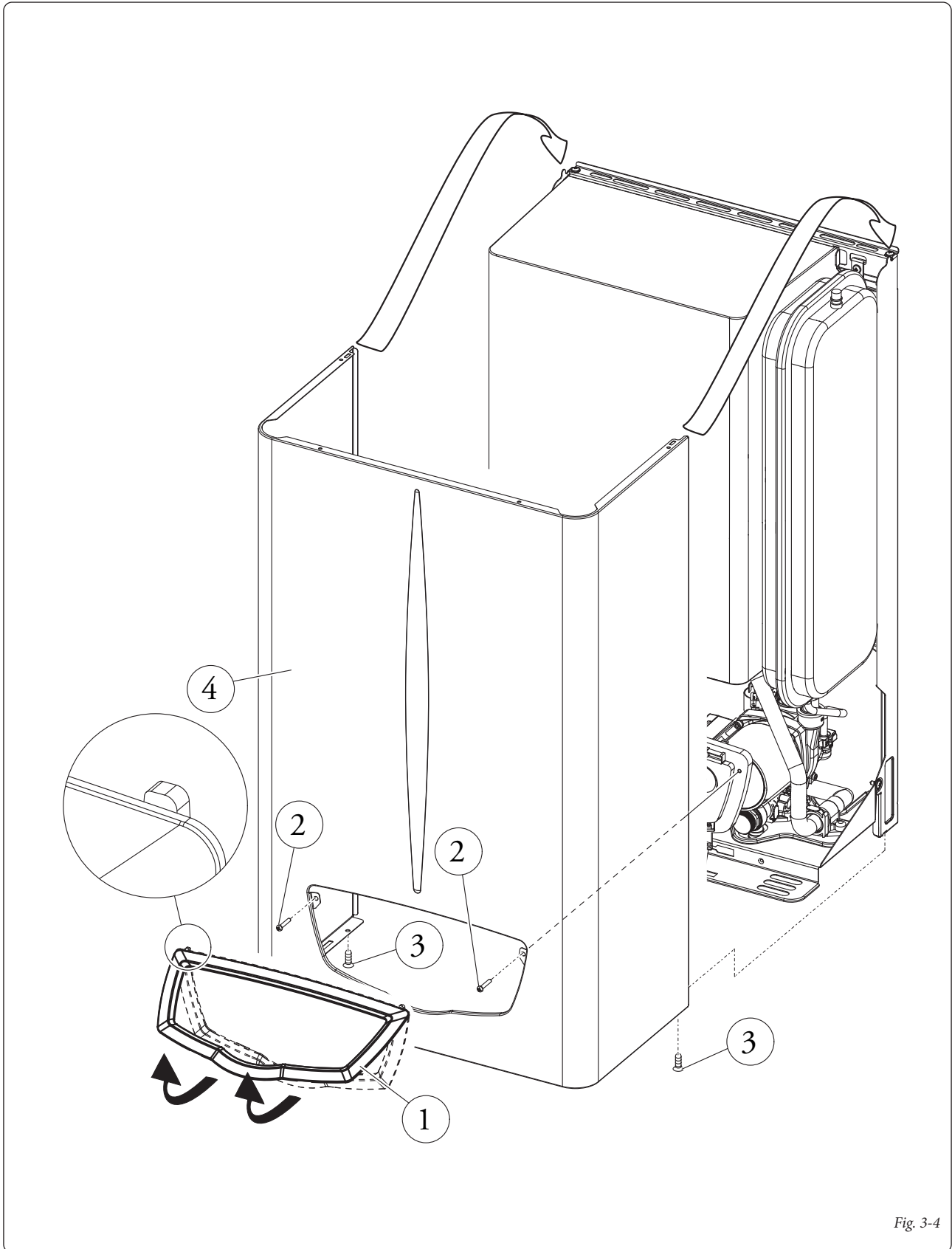

INSTALLER

USER

MAINTENANCE TECHNICIAN

3.15 YEARLY APPLIANCE CHECK AND MAINTENANCE.

The following checks and maintenance should be performed at least once a year.

- Clean the flue side of the heat exchanger.
- Clean the main burner.
- Visually check the draught-breaker/anti-wind device for deterioration or corrosion.
- Check ignition and operation.
- Check correct calibration of the burner in domestic hot water and central heating phases.
- Check the operation of the appliance control and adjustment devices and in particular:
 - intervention of main electrical switch positioned outside of the boiler;
 - system control thermostat intervention;
 - domestic hot water control thermostat intervention.
- Check sealing efficiency of the gas circuit and the internal system.
- Check the intervention of the device against no gas ionisation flame control. Intervention time must be less than 10 seconds.
- Visually check for water leaks or oxidation from/on connections.
- Visually check that the water safety drain valves is not blocked.

- Check that, after discharging system pressure and bringing it to zero (read on boiler pressure gauge), the expansion vessel load is at 1.0 bar.
- Check that the system static pressure (with system cold and after refilling the system by means of the filling valve) is between 1 and 1.2 bar.
- Visually check that the safety and control devices have not been tampered with and/or shorted, in particular:
 - temperature safety thermostat;
 - water pressure switch,
 - flue exhaust control thermostat.
- Check the condition and integrity of the electrical system and in particular:
 - electrical power cables must be inside the fairleads;
 - there must be no traces of blackening or burning.

N.B.: when performing periodical maintenance of the appliance it is also good practice to check and perform maintenance on the heating system, in compliance with that indicated by the regulations in force.

3.16 VARIABLE HEAT OUTPUT.

THERMAL POWER (kW)	THERMAL POWER (kcal/h)		METHANE (G20)			BUTANE (G30)			PROPANE (G31)		
			BURNER GAS FLOW RATE	PRESS. BURNER NOZZLES		BURNER GAS FLOW RATE	PRESS. BURNER NOZZLES		BURNER GAS FLOW RATE	PRESS. BURNER NOZZLES	
			(m ³ /h)	(mbar)	(mm H ₂ O)	(kg/h)	(mbar)	(mm H ₂ O)	(kg/h)	(mbar)	(mm H ₂ O)
23.6	20296	CH + D.H.W.	2.78	12.60	128.5	2.08	26.60	271.3	2.04	34.90	355.9
23.0	19780		2.71	11.99	122.2	2.02	25.67	261.8	1.99	33.24	339.0
22.0	18920		2.59	11.01	112.3	1.94	24.15	246.3	1.90	30.59	312.0
21.0	18060		2.48	10.08	102.8	1.85	22.66	231.1	1.82	28.07	286.3
20.0	17200		2.36	9.21	93.9	1.76	21.19	216.1	1.73	25.68	261.9
19.0	16340		2.25	8.38	85.4	1.68	19.75	201.3	1.65	23.40	238.7
18.0	15480		2.13	7.59	77.4	1.59	18.32	186.8	1.56	21.24	216.6
17.0	14620		2.02	6.85	69.8	1.51	16.91	172.4	1.48	19.19	195.7
16.0	13760		1.90	6.14	62.6	1.42	15.52	158.2	1.40	17.24	175.8
15.0	12900		1.79	5.48	55.9	1.34	14.13	144.1	1.32	15.39	156.9
14.0	12040		1.68	4.86	49.5	1.25	12.76	130.2	1.23	13.63	139.0
13.0	11180		1.57	4.27	43.5	1.17	11.40	116.3	1.15	11.97	122.1
12.0	10320		1.45	3.72	37.9	1.08	10.05	102.5	1.07	10.40	106.1
11.0	9460		1.34	3.20	32.6	1.00	8.70	88.7	0.98	8.92	91.0
10.0	8600		1.23	2.72	27.8	0.91	7.35	75.0	0.90	7.54	76.8
9.5	8170	1.17	2.50	25.5	0.87	6.68	68.1	0.86	6.87	70.1	
8.0	6880	D.H.W.	0.99	1.87	19.1	0.74	4.65	47.5	0.73	5.02	51.2
7.0	6020		0.88	1.50	15.3	0.65	3.30	33.7	0.64	3.90	39.8

N.B.: gas flow rates refer to heating power below a temperature of 15°C and pressure of 1013 mbar. Burner pressure values refer to use of gas at 15°C.

3.17 COMBUSTION PARAMETERS.

		G20	G30	G31
Gas nozzle diameter	mm	1.30	0.80	0.80
supply pressure	mbar (mm H ₂ O)	20 (204)	29 (296)	37 (377)
Flue flow rate at nominal heat output	kg/h	71	69	71
Flue flow rate at min heat output	kg/h	61	55	58
CO ₂ at Nom./Min. Q.	%	5.20 / 1.80	6.20 / 2.34	6.00 / 2.21
CO with 0% O ₂ at Nom./Min. Q.	ppm	61 / 85	104 / 96	64 / 106
NO _x with 0% of O ₂ at Nom./Min. Q.	mg/kWh	147 / 88	242 / 106	242 / 98
Flue temperature at nominal output	°C	112	116	114
Flue temperature at minimum output	°C	91	80	96

Combustion parameters: measuring conditions of useful efficiency (flow temperature/return temperature= 80 / 60 °C), ambient temperature reference = 15°C.

3.18 TECHNICAL DATA.

Nominal heat input	kW (kcal/h)	26.3 (22614)
DHW minimum heat input	kW (kcal/h)	8.3 (7124)
CH minimum heat input	kW (kcal/h)	11.0 (9489)
Nominal heat output (useful)	kW (kcal/h)	23.6 (20296)
DHW minimum heat output (useful)	kW (kcal/h)	7.0 (6020)
CH minimum heat output (useful)	kW (kcal/h)	9.5 (8170)
* Efficiency at nominal heat output	%	89.8
* Efficiency at 30% nominal heat output load	%	88.8
Heat loss at case with burner On/Off	%	2.40 / 1.25
Heat loss at flue with burner On/Off	%	7.90 / 0.10
Central heating circuit max. operating pressure	bar	3
Central heating circuit max. operating temperature	°C	90
Adjustable central heating temperature	°C	38 - 85
System expansion vessel total volume	l	4.2
Expansion vessel factory-set pressure	bar	1
Water content in generator	l	1.9
Head available with 1000 l/h flow rate	kPa (m H ₂ O)	24.5 (2.5)
Hot water production useful heat output	kW (kcal/h)	23.6 (20296)
Domestic hot water adjustable temperature	°C	30 (38) - 60 (77)
Domestic circuit min. pressure (dynamic)	bar	0.3
Domestic hot water circuit max. working pressure	bar	10
Minimum D.H.W. flow rate	l/min	1.5
Flow rate capacity in continuous duty (ΔT 30°C)	l/min	- - -
Weight of full boiler	kg	26.1
Weight of empty boiler	kg	24.2
Electrical connection	V/Hz	230/50
Nominal absorption	A	0.4
Installed electric output	W	100
Pump consumption	W	74
Equipment electrical system protection	-	IPX4D
Boiler flue circuit resistance	Pa	1.3
NO _x class	-	4
Weighted NO _x	mg/kWh	89
Weighted CO	mg/kWh	65.5
Type of appliance	B11BS	
Category	II2H3+	

- The data relevant to domestic hot water performance refer to a dynamic inlet pressure of 2 bar and an inlet temperature of 15°C; the values are measured directly at the boiler outlet considering that to obtain the data declared mixing with cold water is necessary.
- The maximum sound level emitted during boiler operation is < 55dBA. The sound level value is referred to semianechoic chamber tests

with boiler operating at max. heat output, with extension of flue gas exhaust system according to product standards.

* Efficiencies refer to the lower heating value.

INSTALLER

USER

MAINTENANCE TECHNICIAN

3.19 DATA PLATE KEY.

Md		Cod. Md	
Sr N°	CHK	Cod. PIN	
Type			
Q _{nw} /Q _n min.	Q _{nw} /Q _n max.	P _n min.	P _n max.
PMS	PMW	D	TM
NO _x Class			

Note: the technical data are shown on the boiler data plate

	IE
Md	Model
Cod. Md	Model code
Sr N°	Serial Number
CHK	Check
Cod. PIN	PIN code
Type	Type of installation (ref. CEN TR 1749)
Q _{nw} min.	Minimum heating capacity (domestic)
Q _n min.	Minimum heating capacity (heating)
Q _{nw} max.	Maximum heating capacity (domestic)
Q _n max.	Maximum heating capacity (heating)
P _n min.	Minimum heat output
P _n max.	Maximum heat output
PMS	Maximum pressure (system)
PMW	Maximum pressure (domestic)
D	Specific flow rate
TM	Maximum working temperature
NO _x Class	Nox Class

Follow us

Immergas Italia



immergas.com

Immergas S.p.A.
42041 Brescello (RE) - Italy
Tel. 0522.689011
Fax 0522.680617

Certified company ISO 9001

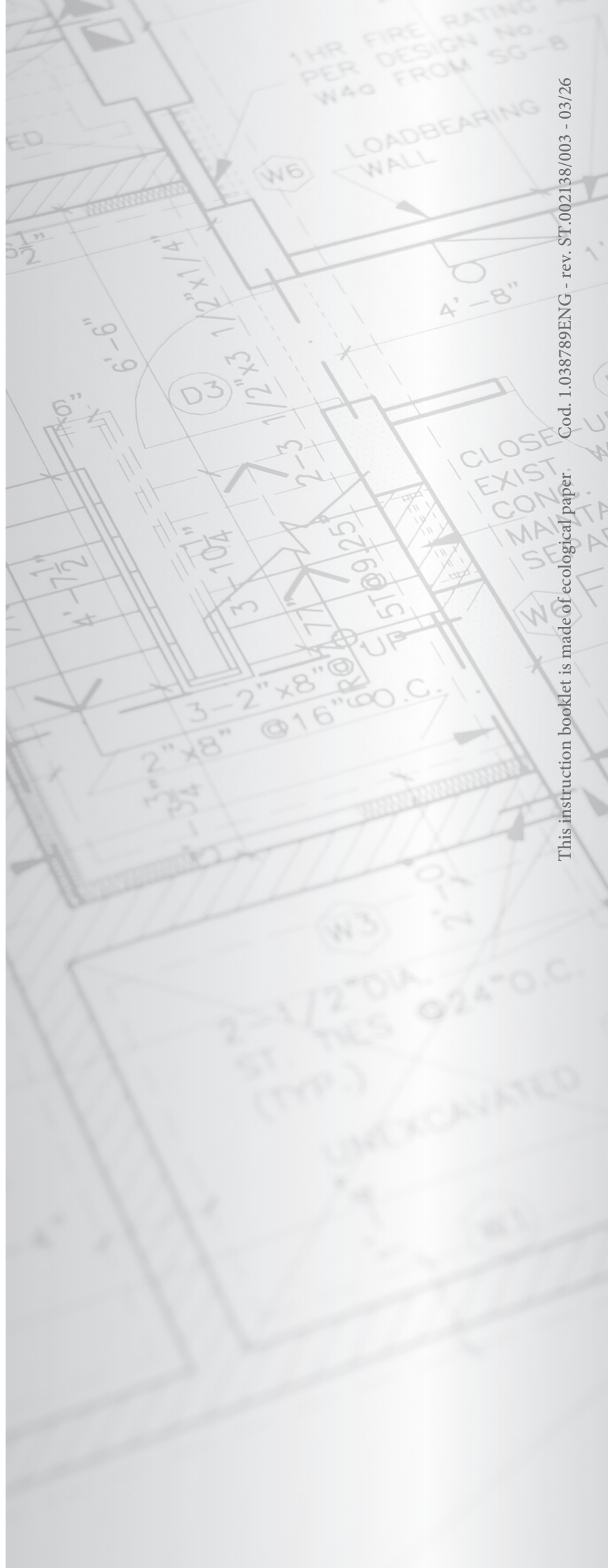

Cod. 1.038789ENG - rev. ST.002138/003 - 03/26
This instruction booklet is made of ecological paper