

USERS

Instructions and IE warning book

 **IMMERGAS**

NIKE STAR 24 4E

1.040472ENG



Dear Customer,

Our compliments for having chosen a top-quality Immergas product, able to assure well-being and safety for a long period of time. As an Immergas Customer, you can also count on a qualified after-sales service, prepared and updated to guarantee constant efficiency of your boiler. Read the following pages carefully: you will be able to draw useful suggestions regarding the correct use of the appliance. By respecting these suggestions, you will no doubt be satisfied with your Immergas product.

For any assistance and scheduled maintenance please contact Authorised After-Sales centres: they have original spare parts and are specifically trained by the manufacturer.

General recommendations

All Immergas products are protected with suitable transport packaging.

The material must be stored in a dry place protected from the weather.

The instruction book is an integral and essential part of the product and must also be given to the new user in the case of transfer or succession of ownership.

It must be stored with care and consulted carefully, as all of the warnings provide important safety indications for installation, use and maintenance stages.

This instructions manual provides technical information for installing Immergas boilers. As for the other issues related to boiler installation (e.g. safety in the work site, environment protection, injury prevention), it is necessary to comply with the provisions specified in the regulations in force and principles of good technique.

In compliance with the legislation in force, the systems must be designed by qualified professionals, within the dimensional limits established by the Law. Installation and maintenance must be performed in compliance with the regulations in force, according to the manufacturer's instructions and by an agreed company, intended as a company with specific technical skills in the system sector, as envisioned by the Law.

Improper installation or assembly of the appliance and/or Immergas components, accessories, kit and devices can cause unexpected problems to people, animals and objects. Read the instructions provided with the product carefully to ensure proper installation.

Maintenance must be carried out by an authorised company. The Authorised After-sales Service represents a guarantee of qualifications and professionalism.

The appliance must only be destined for the use for which it has been expressly declared. Any other use will be considered improper and therefore potentially dangerous.

If errors occur during installation, operation and maintenance, due to non-compliance with technical laws in force, standards or instructions contained in this book (or however supplied by the manufacturer), the manufacturer is excluded from any contractual and extra-contractual liability for any damages and the appliance warranty is invalidated.

Product not intended for EU countries

The manufacturer declines all liability due to printing or transcription errors, reserving the right to make any modifications to its technical and commercial documents without prior notice.

INDEX

INSTALLER page

1	Installation boiler.....	5
1.1	Installation recommendations.....	5
1.2	Main dimensions.....	6
1.3	Antifreeze protection.....	6
1.4	Boiler connection unit.....	6
1.5	Gas connection.....	6
1.6	Hydraulic connection.....	7
1.7	Electrical connection.....	7
1.8	Remote controls and room chrono-thermostats (Optional).....	7
1.9	Ventilation of the rooms.....	8
1.10	Flue ducts.....	8
1.11	Flues/Chimneys.....	8
1.12	Flue gas control device.....	8
1.13	System filling.....	8
1.14	Gas system start-up.....	8
1.15	Boiler start up (ignition).....	9
1.16	Circulation pump.....	9
1.17	Boiler components.....	10
1.18	Kits available on request.....	10

USER page

2	Use and maintenance instructions.....	11
2.1	Cleaning and maintenance.....	11
2.2	Ventilation of the rooms.....	11
2.3	General warnings.....	11
2.4	Control panel.....	11
2.5	Fault and anomaly signals.....	12
2.6	Information Menu.....	13
2.7	Boiler shutdown.....	14
2.8	Restore central heating system pressure.....	14
2.9	Draining the system.....	14
2.10	Antifreeze protection.....	14
2.11	Case cleaning.....	14
2.12	Decommissioning.....	14

MAINTENANCE TECHNICIAN page

3	Commissioning the boiler (initial check).....	15
3.1	Hydraulic Diagram.....	15
3.2	Wiring diagram.....	16
3.3	Troubleshooting.....	17
3.4	Converting the boiler to other types of gas.....	18
3.5	Checks following conversion to another type of gas.....	18
3.6	Possible adjustments.....	18
3.7	Programming the P.C.B.....	19
3.8	Automatic slow ignition function with timed ramp delivery.....	20
3.9	"Chimney sweep" function.....	20
3.10	Heating Timer.....	20
3.11	Pump anti-block function.....	20
3.12	Domestic hot water circuit anti-extruder function.....	20
3.13	Radiators antifreeze function.....	20
3.14	P.C.B. periodical self-check.....	20
3.15	Casing removal.....	21
3.16	Yearly appliance check and maintenance.....	22
3.17	Variable heat output.....	22
3.18	Combustion parameters.....	23
3.19	Technical data.....	23
3.20	Key for Data nameplate.....	24

1 INSTALLATION BOILER.

1.1 INSTALLATION RECOMMENDATIONS.

The Nike Star 24 4E boiler has been designed for wall mounted installation only, for heating environments and production of domestic hot water for domestic use and similar purposes.

The place of installation of the appliance and relative Immergas accessories must have suitable features (technical and structural), such as to allow for (always in safe, efficient and comfortable conditions):

- installation (according to the provisions of technical legislation and technical regulations);
- maintenance operations (including scheduled, periodic, routine and special maintenance);
- removal (to outdoors in the place for loading and transporting the appliances and components) as well as the eventual replacement of those with appliances and/or equivalent components.

The wall surface must be smooth, without any protrusions or recesses enabling access to the rear part. They are not designed to be installed on plinths or floors (Fig. 1).

Only a professionally enabled company is authorised to install Immergas gas appliances. Installation must be carried out according to regulation standards, current legislation and in compliance with local technical regulations and the required technical procedures.

Attention: Immergas declines all liability for damages caused by boilers removed from other systems or for any non-conformities of such equipment.

Installation of the Nike star 24 4E boiler when powered by LPG must comply with the rules regarding gases with a greater density than air (remember, as an example, that it is prohibited to install plants powered with the above-mentioned gas in rooms where the floor is at a lower quota than the average external country one).

Before installing the appliance, ensure that it is delivered in perfect condition; if in doubt, contact the supplier immediately. Packing materials (staples, nails, plastic bags, polystyrene foam, etc.) constitute a hazard and must be kept out of the reach of children. If the appliance is installed inside or between cabinets, ensure sufficient space for normal servicing; therefore it is advisable to leave clearance of at least 3 cm between the boiler casing and the vertical sides of the cabinet. Leave adequate space above the boiler for possible water and flue removal connections. It is just as important that the intake grids are not obstructed. Keep all flammable objects away from the appliance (paper, rags, plastic, polystyrene, etc.). Do not place household appliances underneath the boiler as they could be damaged if the safety valve intervenes (if not conveyed away by a draining funnel), or if there are leaks from the hydraulic connections; otherwise, the manufacturer cannot be held responsible for any damage caused to the household appliances.

In the event of malfunctions, faults or incorrect operation, turn the appliance off and contact an authorised company (e.g. the Authorised Technical Assistance centre, which has specifically trained staff and original spare parts). Do not attempt to modify or repair the appliance alone. Failure to comply with the above implies personal responsibility and invalidates the warranty.

• Installation Standards:

- These boilers cannot be installed in bedrooms, studio flats and bathrooms. They also cannot be installed in rooms with wood (or solid fuel) burning heat generators and in communicating rooms.
- Installation in places with a fire risk is prohibited (for example: underground car parks, garages), potentially dangerous places, gas appliances and relative flue ducts.
- Installation is prohibited on the vertical projection of the cooking surface.
- Installation is forbidden in places/rooms that constitute public areas of apartment buildings, internal stairways or other escape routes (e.g. landings, entrance halls, etc.) unless otherwise provided by local regulations.
- Installation is also forbidden in places/rooms that constitute public areas of apartment buildings such as cellars, entrance halls, attics, lofts, etc., unless otherwise provided for by local regulations in force.
- Type B open chamber boilers must not be installed in places where commercial, artisan or industrial activities take place, which use products that may develop volatile vapours or substances (e.g. acid vapours, glues, paints, solvents, combustibles, etc.), as well as dusts (e.g. dust deriving from the working of wood, coal fines, cement, etc.), which may be damaging for the components of the appliance and jeopardise functioning.
- They must also be installed in an environment in which the temperature cannot fall below 0°C. They must not be exposed to atmospheric agents.
- *For the right functioning of the Nike Star, the pipe the boiler is connected to is to have a minimum vacuum equivalent to the fan assisted of 1 meter of vertical pipe with a diameter of 130 mm.*

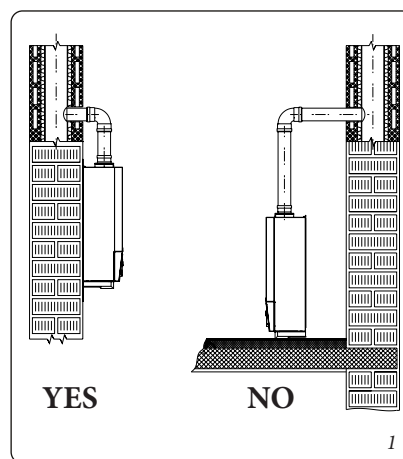

Attention: wall mounting of the boiler must guarantee stable and efficient support for the generator.

The plugs (standard supply) are to be used only in conjunction with the fixing template to fix the boiler to the wall; they only ensure adequate support if inserted correctly (according to technical standards) in walls made of solid or semi-hollow brick or block. In the case of walls made from hollow brick or block, partitions with limited static properties, or in any case walls other than those indicated, a static test must be carried out to ensure adequate mount.

N.B.: the hex head screws supplied in the blister pack are to be used exclusively to fix the relative mounting bracket to the wall.

These boilers are used to heat water to below boiling temperature in atmospheric pressure. They must be connected to a central heating system and domestic hot water circuit suited to their performance and capacity.

INSTALLER

USER

MAINTENANCE TECHNICIAN

1.2 MAIN DIMENSIONS.

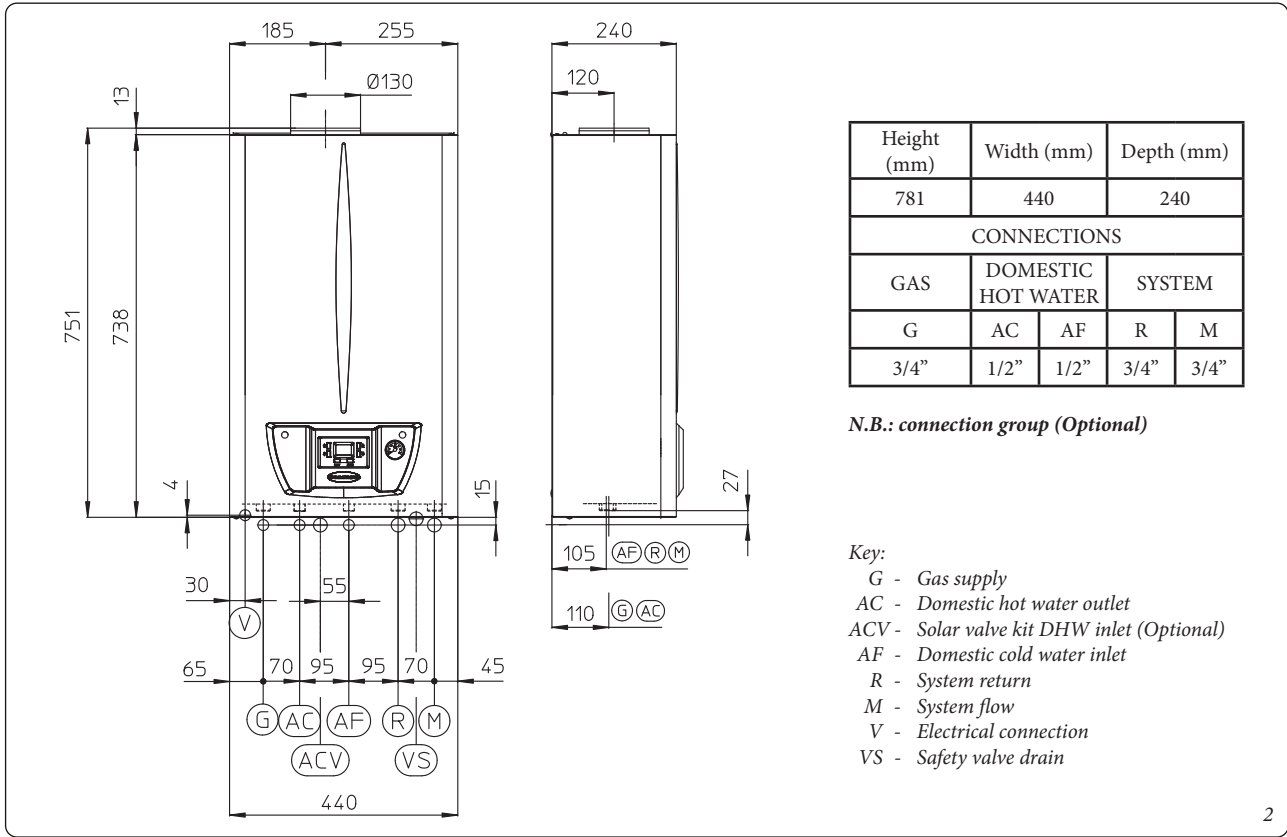

1.3 ANTIFREEZE PROTECTION.

Minimum temperature -5°C. The boiler comes standard with an antifreeze function that activates the pump and burner when the system water temperature in the boiler falls below 4°C. The antifreeze function is only guaranteed if:

- the boiler is correctly connected to gas and electricity power supply circuits;
- the boiler is powered constantly;
- the boiler is not in ignition failure block (Par. 2.3);
- the boiler essential components are not faulty.

In these conditions the boiler is protected against freezing to an ambient temperature of -5°C.

Minimum temperature -15°C. If the boiler is installed in a place where the temperature falls below -5°C and in the event there is no gas or the boiler goes into failed ignition block, the appliance can freeze.

To prevent the risk of freezing follow the instructions below:

- protect the central heating circuit from freezing by inserting a good-quality antifreeze liquid into this circuit, which is specially suited for central heating systems and which is manufacturer guaranteed not to cause damage to the heat exchanger or other components of the boiler. The antifreeze liquid must not be harmful to one's health. The instructions of the manufacturer of this liquid must be followed scrupulously regarding the percentage necessary with respect to the minimum temperature at which the system must be kept.

Warning: the excessive use of glycol could jeopardise the proper functioning of the appliance.

An aqueous solution must be made with potential pollution class of water 2 (EN 1717:2002 or local standards in force).

The materials used for the central heating circuit of Immergas boilers withstand ethylene and propylene glycol based antifreeze liquids (if the mixtures are prepared perfectly).

For life and possible disposal, follow the supplier's instructions.

- Protect the domestic hot water circuit against freezing by using an accessory that is supplied on request (antifreeze kit) comprising two electric heating elements, the relevant wiring and a control thermostat (carefully read the installation instructions contained in the accessory kit pack).

Boiler antifreeze protection is thus ensured only if:

- the boiler is correctly connected to gas and electricity power supply circuits and powered;
- the main switch is engaged;
- the anti-freezing kit components are efficient.

In these conditions the boiler is protected against freezing to temperature of -15°C.

The warranty does not cover damage due to interruption of the electrical power supply and failure to comply with that stated on the previous page.

NOTE: if the boiler is installed in places where the temperature falls below 0°C the domestic hot water and central heating attachment pipes must be insulated.

1.4 BOILER CONNECTION UNIT.

The connection unit consisting of all the necessary parts to perform the hydraulic and gas system connections of the appliance comes as optional.

1.5 GAS CONNECTION.

Our boilers are designed to operate with methane gas (G20) or LPG. Supply pipes must be the same as or larger than the 3/4" G boiler fitting. Before connecting the gas line, carefully clean inside all the fuel feed system pipes to remove any residue that could impair boiler efficiency. Also make sure the gas corresponds to that for which the boiler is prepared (see boiler data nameplate). If different, the boiler must be converted for operation with the other type of gas (see converting appliance for other gas types). The dynamic gas supply (methane or LPG) pressure must also be checked according to the type used in the boiler, which must comply with the regulations in force, as insufficient levels can reduce generator output and cause malfunctions.

Ensure correct gas cock connection. The gas supply pipe must be suitably dimensioned according to current regulations in order to guarantee correct gas flow rate to the burner even in conditions of maximum generator output and to guarantee appliance efficiency (technical specifications). The coupling system must conform to technical standards in force.

Fuel gas quality. The appliance was designed to operate with combustible gas free of impurities; otherwise it is advisable to fit special filters upstream of the appliance to restore the purity of the fuel.

Storage tanks (in case of supply from LPG depot).

- New LPG storage tanks may contain residual inert gases (nitrogen) that degrade the mixture delivered to the appliance casing functioning anomalies.
- Due to the composition of the LPG mixture, layering of the mixture components may occur during the period of storage in the tanks. This can cause a variation in the heating power of the mixture delivered to the appliance, with subsequent change in its performance.

1.6 HYDRAULIC CONNECTION.

Attention: Before making the boiler connections, carefully clean the heating system on the primary heat exchanger (pipes, radiators, etc.) with special pickling or de-scaling products to remove any deposits that could compromise correct boiler operation.

A treatment of the heating and water system water is required, in compliance with the technical standards in force, in order to protect the system and the appliance from deposits (e.g. scale), slurry or other hazardous deposits.

Water connections must be made in a rational way using the couplings on the boiler template. The boiler safety valves outlet must be connected to a draining funnel. Otherwise, the manufacturer declines any responsibility in case of flooding if the drain valve cuts in.

Attention: The manufacturer declines all liability in the event of damage caused by the installation of an automatic filling system.

In order to meet the system requirements established by the technical regulation in force in relation to the pollution of drinking water, we recommend installing the IMMERGAS anti-backflow kit to be used upstream of the cold water inlet connection of the boiler. It is also recommended that the heat transfer fluid (e.g. water + glycol) entered in the primary circuit of the boiler (heating circuit), complies with the local regulations in force.

Attention: to preserve the duration of appliance efficiency features, in the presence of water whose features can lead to the deposit of lime scale, installation of the "polyphosphate dispenser" kit is recommended.

1.7 ELECTRICAL CONNECTION.

The Nike Star 24 4E boiler has an IPX4D protection rating for the entire appliance. Electrical safety of the appliance is reached only when it is correctly connected to an efficient earthing system as specified by current safety standards.

Attention: The manufacturer declines any responsibility for damage or physical injury caused by failure to connect the boiler to an efficient earth system or failure to comply with the reference standards.

Also ensure that the electrical installation corresponds to maximum absorbed power specifications as shown on the boiler data nameplate. Boilers are supplied complete with a "Y" type power cable. The power supply cable must be connected to a 230V ±10% / 50Hz mains supply respecting L-N polarity and earth connection; ⚡ this network must also have a multi-pole circuit breaker with class III overvoltage category. When replacing the power supply cable, contact a qualified firm (e.g. the Authorised After-Sales Technical Assistance Service). The power cable must be laid as shown (Fig. 3). In the event of mains fuse replacement on the P.C.B., use a 3.15 A quick-blow fuse. For the main power supply to the appliance, never use adapters, multiple sockets or extension leads.

1.8 REMOTE CONTROLS AND ROOM CHRONO-THERMOSTATS (OPTIONAL).

The boiler is prepared for the application of room chrono-thermostats or remote controls, which are available as optional kits (Fig. 4 - 5). All devices are connected with 2 wires only. Carefully read the user and assembly instructions contained in the accessory kit.

- On/Off digital chrono-thermostat. The chrono-thermostat allows:
 - set two room temperature value: one for day (comfort temperature) and one for night (reduced temperature);
 - set a weekly programme with four daily switch on and switch off times;
 - selecting the required function mode from the various possible alternatives:
- manual mode (with adjustable temperature).
- automatic mode (with set programme).
- forced automatic mode (momentarily changing the temperature of the automatic programme).

The chrono-thermostat is powered by two 1.5V LR 6 type alkaline batteries.

- Digital Remote Mini-Control Device with climate chrono-thermostat and CAR^{V2} function. In addition to the functions described in the previous point, the Mini-DRC and CAR^{V2} panels enable the user to control all the important information regarding operation of the appliance and the central heating system with the opportunity of easily intervening on the previously set parameters without having to go to the place where the appliance is installed. The Mini CRD and CAR^{V2} panels are equipped with self-diagnosis to display any boiler functioning anomalies. The climate regulator incorporated into the remote panels enables the system flow temperature to be adjusted to the actual needs of the room being heated, in order to obtain the desired room temperature with extreme precision and therefore with evident saving in running costs. The Mini CRD and CAR^{V2} are fed directly by the boiler by means of the same 2 wires used for the transmission of data between the boiler and devices.

Digital Remote Mini-Control or CAR^{V2} or On/Off chrono-thermostat electrical connections (Optional). *The operations described below must be performed after having removed the voltage from the appliance.* Any room chrono-thermostats or remote controls must be connected to the 40 and 41 terminal blocks, eliminating the X40 jumper (Fig. 3-2). Make sure that the On/Off thermostat contact is of the "clean" type, i.e. independent of the mains voltage, otherwise the P.C.B. would be damaged. The boiler can only be connected to one device at a time.

Important: if the Mini CRD or CAR^{V2} remote control is used, arrange two separate lines in compliance with current regulations regarding electrical systems. No boiler pipes must ever be used to earth the electric system or telephone lines. Ensure elimination of this risk before making the boiler electrical connections.

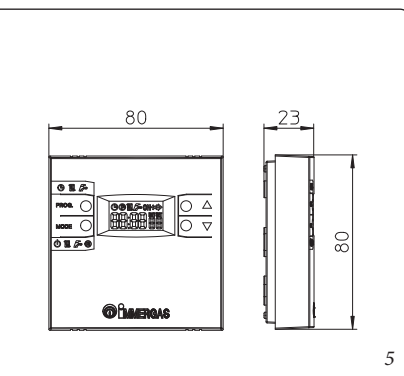
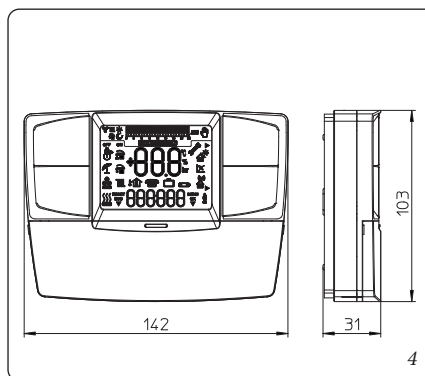
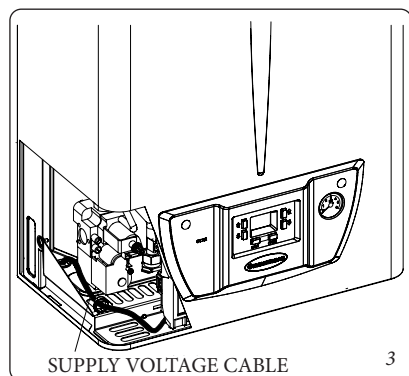

1.9 VENTILATION OF THE ROOMS.

In the room in which the boiler is installed it is necessary that at least as much air flows as that requested for by normal combustion of the gas and ventilation of the room. Natural air flow must take place directly through:

- permanent openings in the walls of the room to be ventilated that lead towards the outside;
- ventilation pipes, individual or branched type.

The air used for ventilation must be withdrawn directly from outside, in an area away from sources of pollution. Natural air flow is also allowed indirectly by air intake from adjoining rooms. For further information relative to ventilation of the rooms follow that envisioned in the current technical regulation.

Evacuation of foul air. In the rooms where the gas appliances are installed it may also be necessary, as well as the intake of combustion agent air, to evacuate foul air, with consequent intake of a further equal amount of clean air. This must be realised respecting the provisions of the technical regulations in force.

1.10 FLUE DUCTS.

The gas appliances with attachment for the flue gas discharge pipe must have direct connection to chimneys or safely efficient flues.

The combustion products can be discharged directly outside only if these are missing, as long as the standard regulations for the flue terminal are respected as well as the existing laws.

Connection to chimneys or flues. The connection of the appliances to a chimney or flue takes place by means of flue ducts.

In the event of fittings with pre-existing flues, these must be perfectly clean because the detachment of any waste from the walls during functioning, could block the passage of flue gases, thus causing extremely dangerous situations for the user.

The flue ducts must be connected to the chimney or flue in the same room in which the appliance is installed or, at most, in the adjoining room and must comply with the requisites of this regulation.

1.11 FLUES/CHIMNEYS.

For the appliances with natural draught individual chimneys and branched flues can be used.

Individual chimneys. The individual flues must be dimensioned with respect to the standard in force.

Branched flues. In buildings with lots of floors, branched flues can be used for the natural draught evacuation of combustion products. New flues must be designed following the calculation method and provisions of the regulation.

Chimney caps. The chimney cap is a device positioned on the top of an individual chimney or branched collective flue. This device promotes the dispersion of combustion products, even in adverse weather conditions, and prevents the deposit of foreign bodies.

It must satisfy the requisites set forth in the relative regulation.

The outlet quota, corresponding to the top of the chimney/flue, independently of any caps, must be out of the "backflow area", in order to prevent the formation of counter-pressures that impede the free discharge of the combustion products into the atmosphere. It is therefore necessary to use the minimum heights indicated in the figures stated in the regulation, depending on the slope of the roof.

Direct exhaust outside. The natural draught appliances, envisioned to be connected to a chimney or a flue, can discharge the combustion products directly to the outside, through a pipe passing through the perimeter walls of the building. In this case discharge takes place through an exhaust flue, which is connected to a draught terminal at the outside.

Exhaust flue. The exhaust flue must be in compliance with the same requisites listed for the flue ducts, with further provisions stated in the regulation in force.

Positioning the draught terminals. The draught terminals must:

- be installed on external perimeter walls of the building;
- be positioned according to the minimum distances specified in current technical standards.

Fume exhaust of forced draught appliances in closed open-top environments. In spaces closed on all sides with open tops (ventilation pits, courtyards etc.), direct flue gas exhaust is allowed for natural or forced draught gas appliances with a heating power range from 4 to 35 kW, provided the conditions as per the current technical standards are respected.

1.12 FLUE GAS CONTROL DEVICE.

Important: it is prohibited to put the fumes exhaust control device out of order voluntarily. Every piece of this device must be replaced using original spare parts if they have deteriorated. In the case of repeated interventions of the fumes exhaust control device, check the fumes exhaust flue and the ventilation of the room in which the boiler is located.

For the right functioning of the Nike Star, the pipe the boiler is connected to is to have a minimum vacuum equivalent to the fan assisted of 1 meter of vertical pipe with a diameter of 130 mm.

1.13 SYSTEM FILLING.

Once the boiler is connected, proceed with system filling via the filling cock (Fig. 7 Fig. 7). Filling is performed at low speed to ensure release of air bubbles in the water via the boiler and central heating system vents.

The boiler has a built-in automatic venting valve on the circulator. *Check if the cap is loose (Ref. 15 Fig. 7 and Ref. 13 Fig. 10).* Open the radiator vent valves.

Close radiator vent valves when only water escapes from them.

Close the filling valve when the boiler pressure gauge indicates approx. 1.2 bar.

1.14 GAS SYSTEM START-UP.

To start up the system, refer to the technical standard in force: In particular, for new gas systems:

- open windows and doors;
- avoid presence of sparks or naked flames;
- bleed all air from pipelines;
- Check that the internal system is properly sealed according to technical regulations in force;

1.15 BOILER START UP (IGNITION).

To commission the boiler (the operations listed below must only be performed by a qualified firm and without any unauthorised persons):

- check that the internal system is properly sealed according to technical regulations in force;
- ensure that the type of gas used corresponds to boiler settings;
- check that there are no external factors that may cause the formation of fuel pockets;
- switch the boiler on and ensure correct ignition;
- make sure that the gas flow rate and relevant pressure values comply with those given in the manual (Par. 3.17);
- check the correct ventilation of the rooms;
- check the existing draught during normal functioning of the appliance, e.g. a draught gauge positioned at the exit of the appliance combustion products;
- check that there is no backflow of combustion products into the room, even during functioning of fans;
- ensure that the safety device is engaged in the event of gas supply failure and check activation time;
- check activation of the main switch located upstream from the boiler.

The boiler must not be started up even if only one of the checks should be negative.

1.16 CIRCULATION PUMP.

The Nike Star 24 4E series boilers are supplied with a built-in circulation pump with three-position electric speed control. The boiler does not operate correctly with the circulation pump on first speed. To ensure optimal boiler operation, in the case of new systems (single pipe and module) it is recommended to use the pump at maximum speed. The circulation pump is already fitted with a condenser.

Pump release. If, after a prolonged period of inactivity, the circulation pump is blocked, unscrew the front cap and turn the motor shaft using a screwdriver. Take great care during this operation to avoid damage to the motor.

By-pass Regulation (Part. 19 Fig. 7). If necessary, the by-pass can be adjusted according to system requirements from a minimum (by-pass excluded) to a maximum (by-pass inserted) represented by the graph (Fig. 6). Make the adjustment using a flat head screwdriver, turn clockwise and insert the by-pass; by turning it anti-clockwise it is excluded.

Head available to the system.

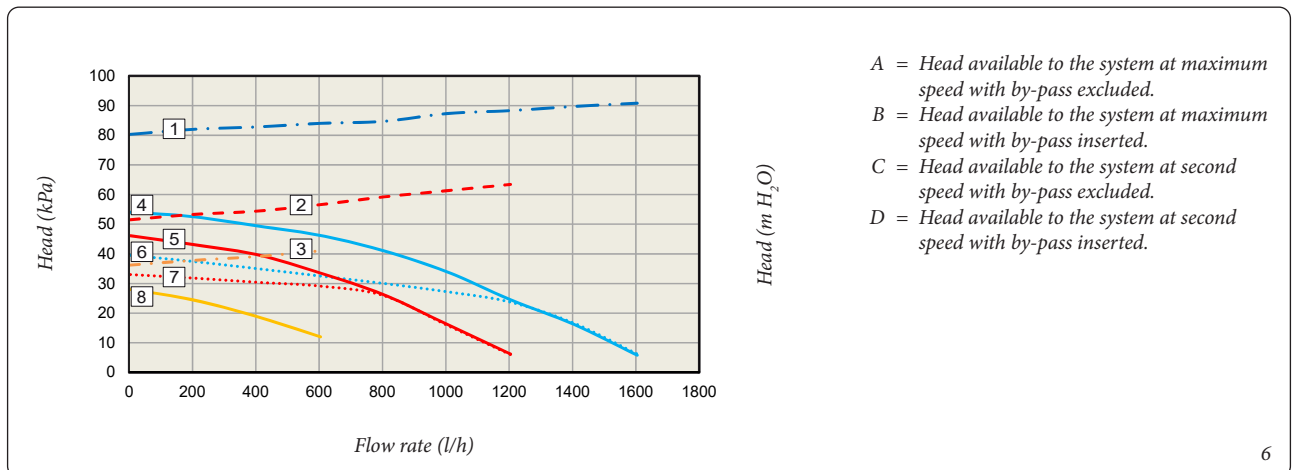

- A = Head available to the system at maximum speed with by-pass excluded.
- B = Head available to the system at maximum speed with by-pass inserted.
- C = Head available to the system at second speed with by-pass excluded.
- D = Head available to the system at second speed with by-pass inserted.

1.17 BOILER COMPONENTS.

INSTALLER

USER

MAINTENANCE TECHNICIAN

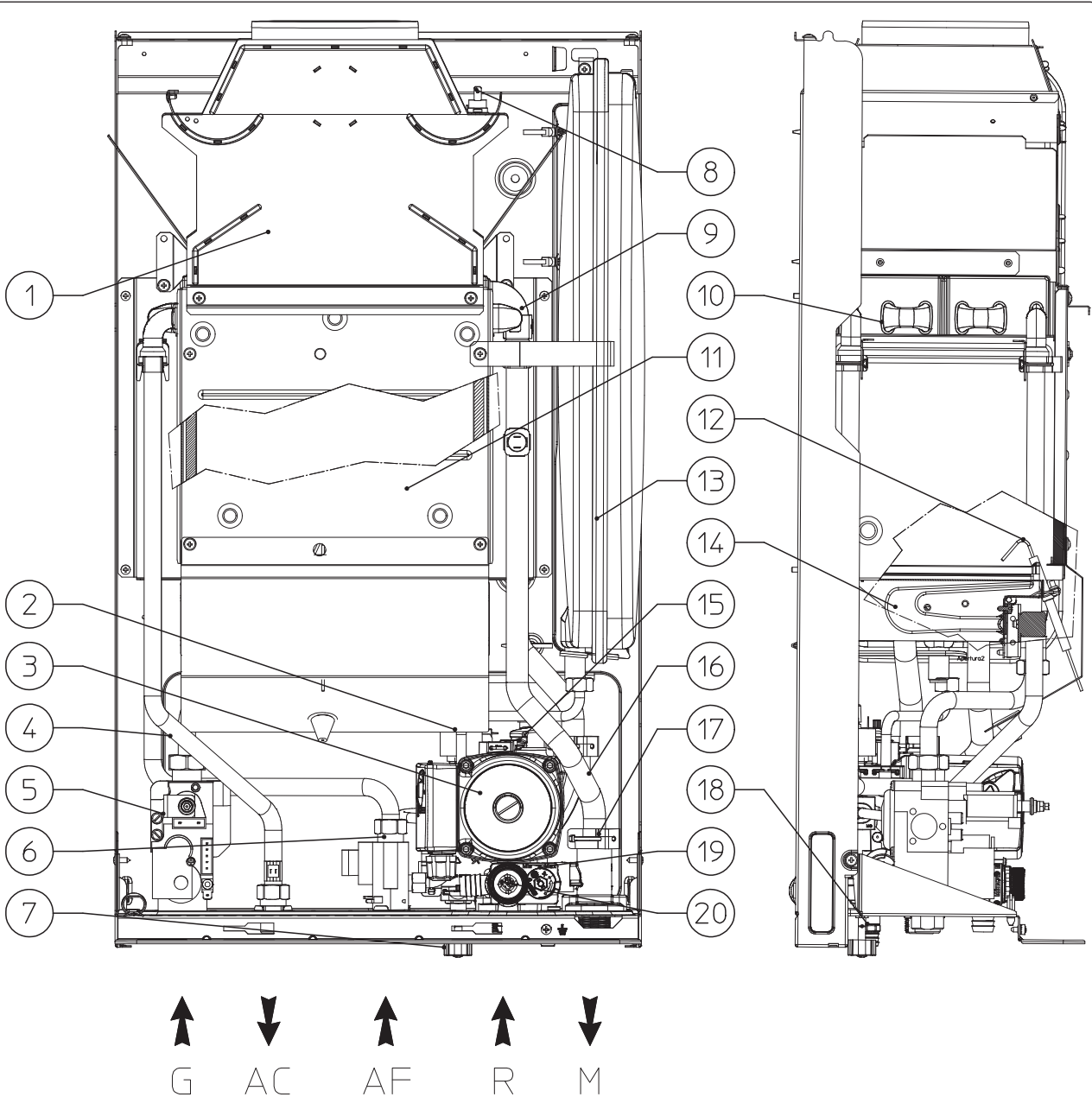

Key:

- | | | |
|----------------------------|--|----------------------------|
| 1 - Flue hood | 9 - Flow probe | 18 - System draining valve |
| 2 - System pressure switch | 10 - Rapid heat exchanger | 19 - By-pass |
| 3 - Boiler pump | 11 - Combustion chamber | 20 - 3 bar safety valve |
| 4 - D.H.W. probe | 12 - Ignition and detection electrodes | |
| 5 - Gas valve | 13 - System expansion vessel | |
| 6 - D.H.W. flow switch | 14 - Burner | |
| 7 - System filling valve | 15 - Air vent valve | |
| 8 - Flue safety thermostat | 16 - Safety thermostat | |
| | 17 - Manifold | |

PLEASE NOTE: connection group (optional)

7

1.18 KITS AVAILABLE ON REQUEST.

- System cut-off valves kit. The boiler is designed for installation of system interception cocks to be placed on flow and return pipes of the connection assembly. This kit is particularly useful for maintenance as it allows to drain just the boiler without having to empty the entire system.

- Polyphosphate dispenser kit. The polyphosphate dispenser reduces the formation of lime-scale and preserves the original heat exchange and domestic hot water production conditions. The boiler is prepared for application of the polyphosphate dispenser kit.
- Connection unit kit. It includes pipes, fittings and cocks (including gas cock), to carry out all connections to the boiler system.

- Anti freeze kit with resistance (on request). If the boiler is installed in a place where the temperature falls below -5°C and in the event there is no gas, the appliance can freeze. To prevent freezing of the domestic hot water system, an anti freeze kit with an electrical resistance can be fitted from the relative cable and from a control thermostat.

Kits are supplied complete with instructions for their assembly and use.

2 USE AND MAINTENANCE INSTRUCTIONS.

2.1 CLEANING AND MAINTENANCE.

Attention: to preserve the boiler's integrity and keep the safety features, performance and reliability which distinguish it unchanged over time, maintenance operations must be carried out on a yearly basis in compliance with that stated in the "annual check and maintenance of the appliance" section, in compliance with national, regional, or local standards in force.

2.2 VENTILATION OF THE ROOMS.

In the room in which the boiler is installed it is necessary that at least as much air flows as that requested for by normal combustion of the gas and ventilation of the room. The provisions relative to ventilation, the flue ducts and multiple flues are stated in *Par. 1.9, 1.10, 1.11 and 1.12*. If in doubt regarding correct ventilation, contact a qualified company.

2.3 GENERAL WARNINGS.

Never expose the wall-mounted boiler to direct vapours from a cooking surface.

Use of the boiler by unskilled persons or children is strictly prohibited.

If temporary shutdown of the boiler is required, proceed as follows:

- drain the heating system if anti-freeze is not used;
- shut-off all electrical, water and gas supplies.

In the case of work or maintenance to structures located in the vicinity of ducting or devices for flue extraction and relative accessories, switch off the appliance and on completion of operations ensure that a qualified technician checks efficiency of the ducting or other devices.

Never clean the appliance or connected parts with easily flammable substances.

Never leave containers or flammable substances in the same environment as the appliance.

It is prohibited and dangerous to obstruct the air intake, even partially, for the ventilation of the room in which the boiler is installed.

Due to the danger, operation is also prohibited in the same room as suction devices or the like, at the same time as the boiler unless there are additional openings dimensioned in a way to satisfy the additional requirement for air. For the dimensioning of these additional openings, refer to an authorised company.

• **Attention:** using any components that use electrical power requires some fundamental rules to be observed:

- do not touch the appliance with wet or moist parts of the body; do not touch when bare-foot;
- never pull electrical cables or leave the appliance exposed to atmospheric agents (rain, sunlight, etc.);
- the appliance power cable must not be replaced by the user;
- in the event of damage to the cable, switch off the appliance and contact exclusively qualified staff for replacement;

- if the appliance is not to be used for a certain period, disconnect the main power switch.

N.B.: the temperatures indicated by the display have a tolerance of +/- 3°C due to environmental conditions that cannot be attributed to the boiler.

At the end of its service life, the appliance must not be disposed of like normal household waste nor abandoned in the environment, but must be removed by a professionally authorised company. Contact the manufacturer for disposal instructions.

2.4 CONTROL PANEL.

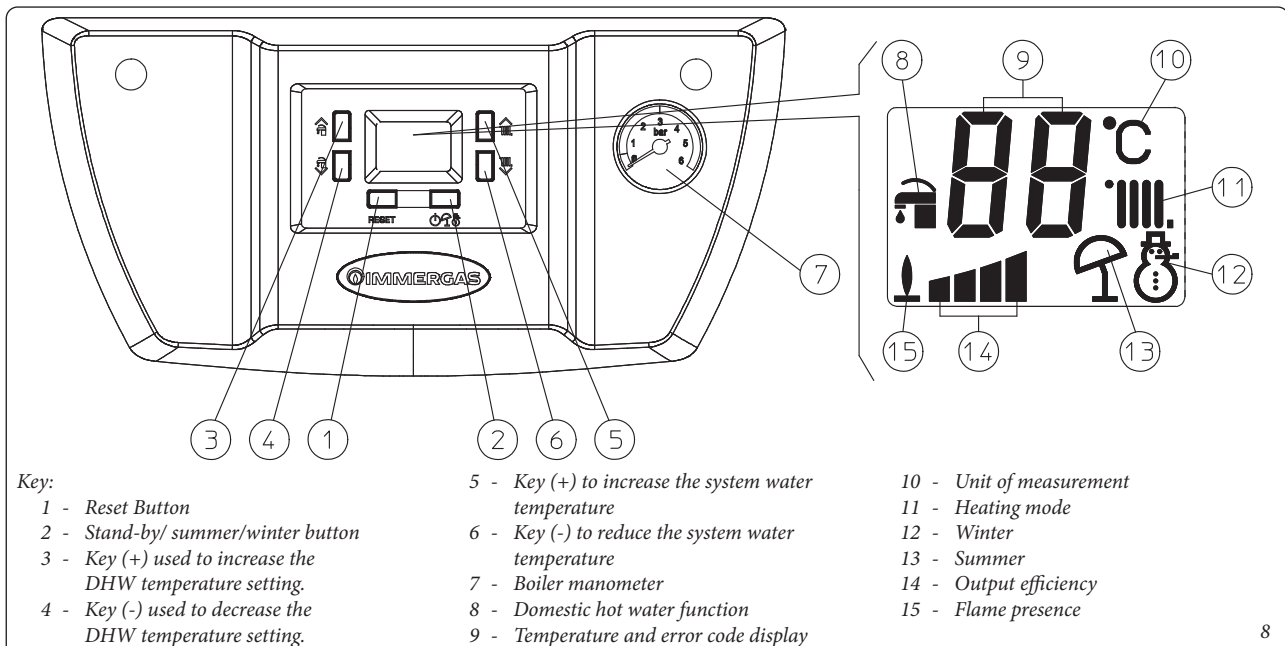

INSTALLER

USER

MAINTENANCE TECHNICIAN

Boiler ignition (see Figure). Before ignition make sure the heating system is filled with water and that the manometer (7) indicates a pressure of $1 \div 1.2$ bar.

- Open the gas cock upstream from the boiler.
- Press key (2) and set the boiler on Summer (☀) or Winter (❄).

When in summer position (☀) the domestic hot water temperature is adjusted with the buttons (3-4).

When the winter position is selected (❄) the system water temperature is adjusted with the buttons (5-6), whilst the domestic hot water temperature is adjusted using the buttons (3-4), by pressing (+) to increase and (-) to reduce the temperature.

From this moment the boiler functions automatically. With no demand for heat (central heating or domestic hot water production) the boiler goes to "standby" function, equivalent to the boiler

being powered without presence of flame. Each time the boiler ignites, the relative flame present symbol is displayed (15).

2.5 FAULT AND ANOMALY SIGNALS.

The boiler signals out anomalies by flashing on the display and relative error codes, listed on the table, are displayed.

Error Code	Anomaly signalled	Cause	Boiler status / Solution
01	No ignition block	In the event of request of room central heating or domestic hot water production, the boiler does not switch on within the preset time. Upon appliance commissioning or after extended downtime, it may be necessary to eliminate the block.	Press the Reset button (1)
02	Safety thermostat block (over-temperature)	During normal operation, if a fault causes excessive overheating internally, the boiler goes into overheating block.	After an appropriate cooling press the Reset button (1)
03	Flue safety thermostat block	During normal operation, if a fault causes excessive flue gas overheating, the boiler blocks	The boiler will automatically restart after 30 minutes if normal conditions resume without having to be reset. After three trippings of the flue safety thermostat in less than two hours the boiler requires a manual reset to restart and wait for further 30 minutes. Press the Reset button (1)
05	Flow probe anomaly	The board detects an anomaly on the flow NTC probe.	The boiler does not start (1)
06	Domestic hot water probe anomaly	The board detects an anomaly on the domestic hot water NTC probe. In this case the antifreeze function is also inhibited	The boiler does not produce domestic hot water (1)
08	Maximum N° of resets	Number of allowed resets already performed.	Attention: the anomaly can be reset 5 times consecutively, after which the function is inhibited for at least one hour. One attempt is gained every hour for a maximum of 5 attempts. By switching the appliance on and off the 5 attempts are re-acquired.
10	Insufficient system pressure	Water pressure inside the central heating circuit that is sufficient to guarantee the correct operation of the boiler is not detected.	Check on the boiler pressure gauge (1) that the system pressure is between $1 \div 1.2$ bar and restore the correct pressure if necessary.
20	Parasite flame block	This occurs in the event of a leak on the detection circuit or anomaly in the flame control unit.	Press the Reset button (1)
24	Push button control panel anomaly	The board detects an anomaly on the pushbutton panel.	If normal conditions are restored the boiler restarts without having to be reset (1).
27	Insufficient water circulation.	This occurs if there is overheating in the boiler due to insufficient water circulating in the primary circuit; the causes can be: - low circulation; - circulator pump blocked.	- check that no shutoff devices are closed on the heating circuit and that the system is free of air (deaerated); - free the circulating pump. (1)
28	Domestic hot water leakage	If during the heating phase, a rise in domestic hot water temperature occurs, an anomaly is signalled and heating temperature is reduced to limit the formation of limescale in the heat exchanger.	Check that all domestic hot water system cocks are closed and are not drawing and check also that there are no leaks in the system. Once good conditions are restored in the domestic hot water system, the boiler returns to normal functioning (1)
31	Loss of remote control communication.	This occurs if an incompatible remote control is connected, or if communication between the boiler and the remote control is lost.	Disconnect and reconnect the power to the boiler. If the Remote Control is not detected on re-starting the boiler will switch to "Summer" local operating mode. In this case, the controls on the control panel of the boiler are enabled again (1).
36	IMG BUS communication loss	Communication loss on the IMG BUS protocol	The boiler does not satisfy the room heating requests (1).
37	Low power supply voltage	This occurs when the power supply voltage is lower than the allowed limits for the correct boiler operation.	If normal conditions are restored the boiler restarts without having to be reset (1).

(1) If the shutdown or fault persists, contact an authorised company (e.g. Authorised Technical After-Sales Service).

Error Code	Anomaly signalled	Cause	Boiler status / Solution
38	Loss of flame signal	This occurs when the boiler is ignited correctly and the burner flame switches off unexpectedly; a new attempt at ignition is performed and if normal conditions are restored, the boiler does not have to be reset.	(1).
43	Block due to loss of flame signal	This occurs if the "Flame signal loss (38)" error occurs many times in a row within a preset period.	Press the Reset button (1).
44	Block for exceeding the maximum openings close to the gas valve	This occurs if the gas valve remains open for longer than required for normal operation, without the boiler switching on.	Press the Reset button (1).
59	Supply voltage frequency anomaly	The board detects a main supply voltage frequency anomaly.	The boiler does not start (1).
80	Failure signalled of the gas valve modulator pilot circuit	Possible failure to the gas valve modulator or electronic board, cut-off wiring. The boiler operates to the minimum DHW output.	Check the wiring connection and modulator coil continuity (1).
98	Block - maximum no. of software errors	The maximum number of software errors possible has been reached.	Press the Reset button (1).

(1) If the shutdown or fault persists, contact an authorised company (e.g. Authorised Technical After-Sales Service).

2.6 INFORMATION MENU.

Pressing the buttons (3) and (4) simultaneously for 3 seconds, the "Information menu" is activated, which displays some boiler functioning parameters.

Press buttons (3) and (4) to scroll through the various parameters. To exit the menu, press buttons (3) and (4) simultaneously again for 3 seconds or wait for 5 minutes.

List of parameters

Id Parameter	Description
d1	Displays the flame signal
d2	Displays the primary exchanger output instant flow temperature (flow probe)
d3	Displays the instant output temperature from the DHW exchanger (DHW probe)
d4	Not used
d5	Displays the operating instantaneous power (value in %).
d6	Displays the actual temperature for the central heating set (if remote control is present)
d7	Displays the temperature set for the DHW set (if remote control is present)
E1 - E7	Display the anomaly history, of which E1 is the most recent

Resetting the anomaly history.

Press the Reset button on the information menu for > 2 seconds and < 4.5 seconds. "E-" will appear on the display.

Only during this time, if you release the button, it resets the anomaly history.

2.7 BOILER SHUTDOWN.

Press the button (*part. 2 Fig. 8*) (⏻) until the symbol appears on the display (→→).

NOTE: in these conditions the boiler is still powered.

Disconnect the external omnipolar boiler switch and close the gas cock upstream of the appliance. Never leave the boiler switched on if left unused for prolonged periods.

2.8 RESTORE CENTRAL HEATING SYSTEM PRESSURE

Periodically check the system water pressure. The boiler pressure gauge should read a value of between 1 and 1.2 bar.

If the pressure is below 1 bar (with the circuit cool) restore normal pressure via the filling cock located in the lower part of the boiler (Fig. 9).

N.B.: close the valve after the operation.

If pressure values reach around 3 bar the safety valve may be activated.

In this case, remove water from an air vent valve of a radiator until 1 bar is reached or ask for assistance from an authorised company.

In the event of frequent pressure drops, contact a qualified firm for assistance to remove any system leakage.

2.9 DRAINING THE SYSTEM.

To drain the boiler, use the special draining valve (*Fig. 9 and 7*).

Before draining, ensure that the filling cock is closed.

2.10 ANTIFREEZE PROTECTION.

The boiler comes standard with an antifreeze function that activates the pump and burner when the system water temperature in the boiler falls below 4°C (standard protection up to the min. temperature of -5°C) and stops once it exceeds 42°C. The antifreeze function is guaranteed if the boiler is fully operative and not in “block” status, and is electrically powered. To avoid keeping the system switched on in case of a prolonged absence, the system must be drained completely or antifreeze substances must be added to the heating system water. In both cases the boiler domestic hot water circuit must be drained. In systems that are drained frequently, filling must be carried out with suitably treated water to eliminate hardness that can cause lime-scale. All information relative to the anti-freeze protection is stated in *Par. 1.3*. In order to guarantee the integrity of the appliance and the domestic hot water heating system in areas where the temperature falls below zero, we recommend the central heating system is protected using anti-freeze liquid and installation of the *Immergas Anti-freeze Kit* in the boiler. In the case of prolonged inactivity (second case), we also recommend that:

- disconnect the electric power supply;
- empty the boiler domestic hot water circuit via the drain valves (*Fig. 7*) and the internal domestic hot water distribution network.

2.11 CASE CLEANING.

Use damp cloths and neutral detergent to clean the boiler casing. Never use abrasive or powder detergents.

2.12 DECOMMISSIONING.

In the event of permanent shutdown of the boiler, contact an authorised company for the suitable procedures and also ensure the electrical, water and fuel supply lines are shut off and disconnected.

BOTTOM VIEW

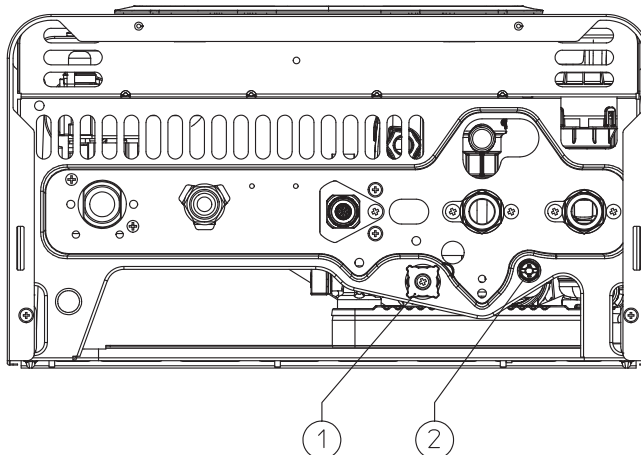

Key:
 1 - Filling valve
 2 - Draining valve

3 COMMISSIONING THE BOILER (INITIAL CHECK).

To commission the boiler:

- ensure that the type of gas used corresponds to boiler settings;
- check connection to a 230V-50Hz power mains, correct L-N polarity and the earthing connection;
- make sure the central heating system is filled with water and that the boiler manometer indicates a pressure of 1 ± 1.2 bar.
- switch the boiler on and ensure correct ignition;
- make sure the gas maximum, medium and minimum flow rate and pressure values correspond to those given in the handbook (Paragraph 3.17);
- check activation of the safety device in the event of no gas, as well as the relative activation time;

- check activation of the main switch located upstream from the boiler;
- check the existing draught during normal functioning of the appliance, e.g. a draught gauge positioned at the exit of the appliance combustion products;
- check that there is no backflow of combustion products into the room, even during functioning of fans;
- ensure activation of all adjustment devices;
- seal the gas flow rate regulation devices (if settings are modified);
- ensure production of domestic hot water;
- ensure sealing efficiency of water circuits;
- check ventilation and/or aeration of the installation room where provided.

Even if just one single safety check provides a negative result, do not commission the system.

3.1 HYDRAULIC DIAGRAM.

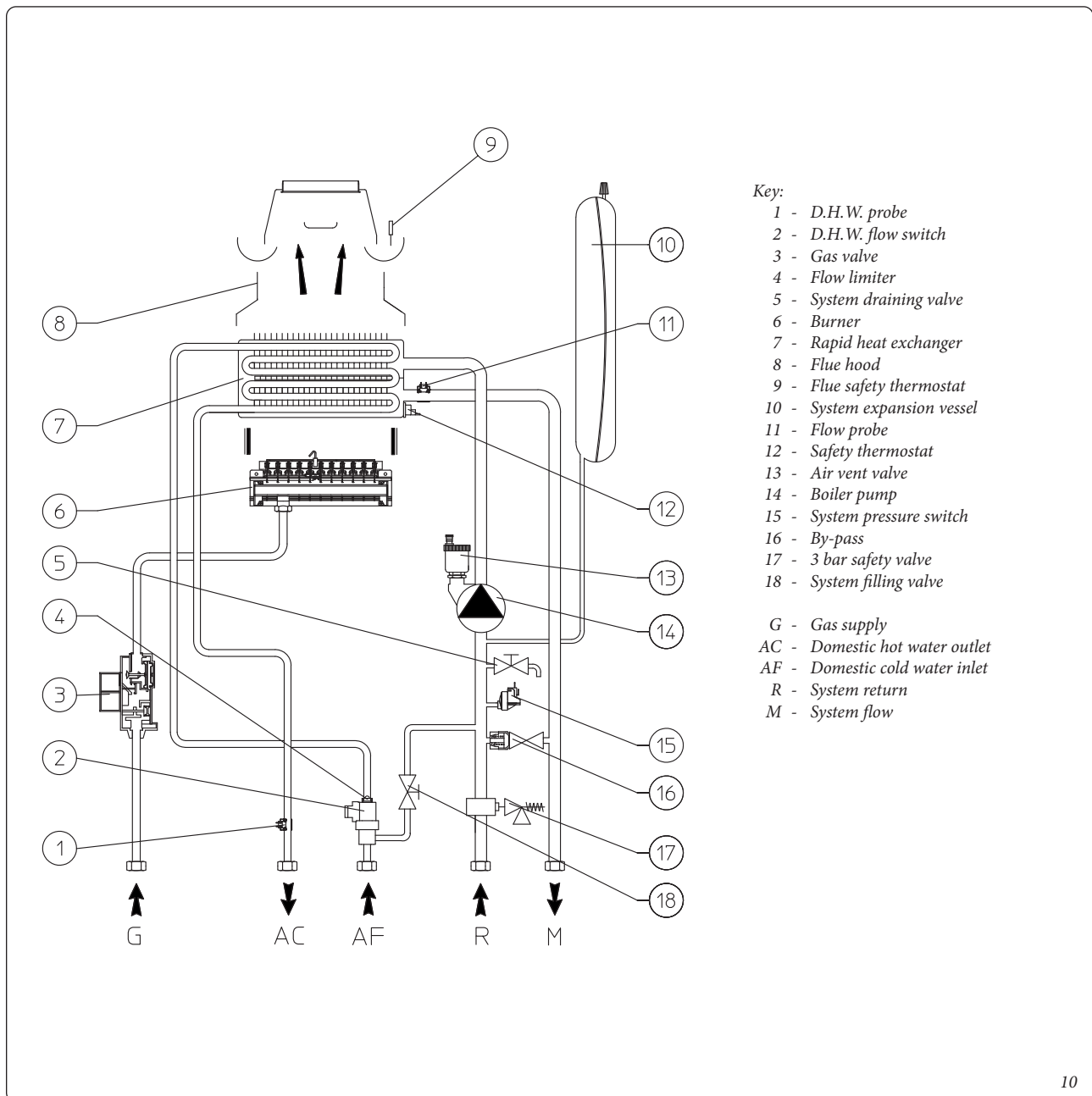

INSTALLER

USER

MAINTENANCE TECHNICIAN

3.2 WIRING DIAGRAM.

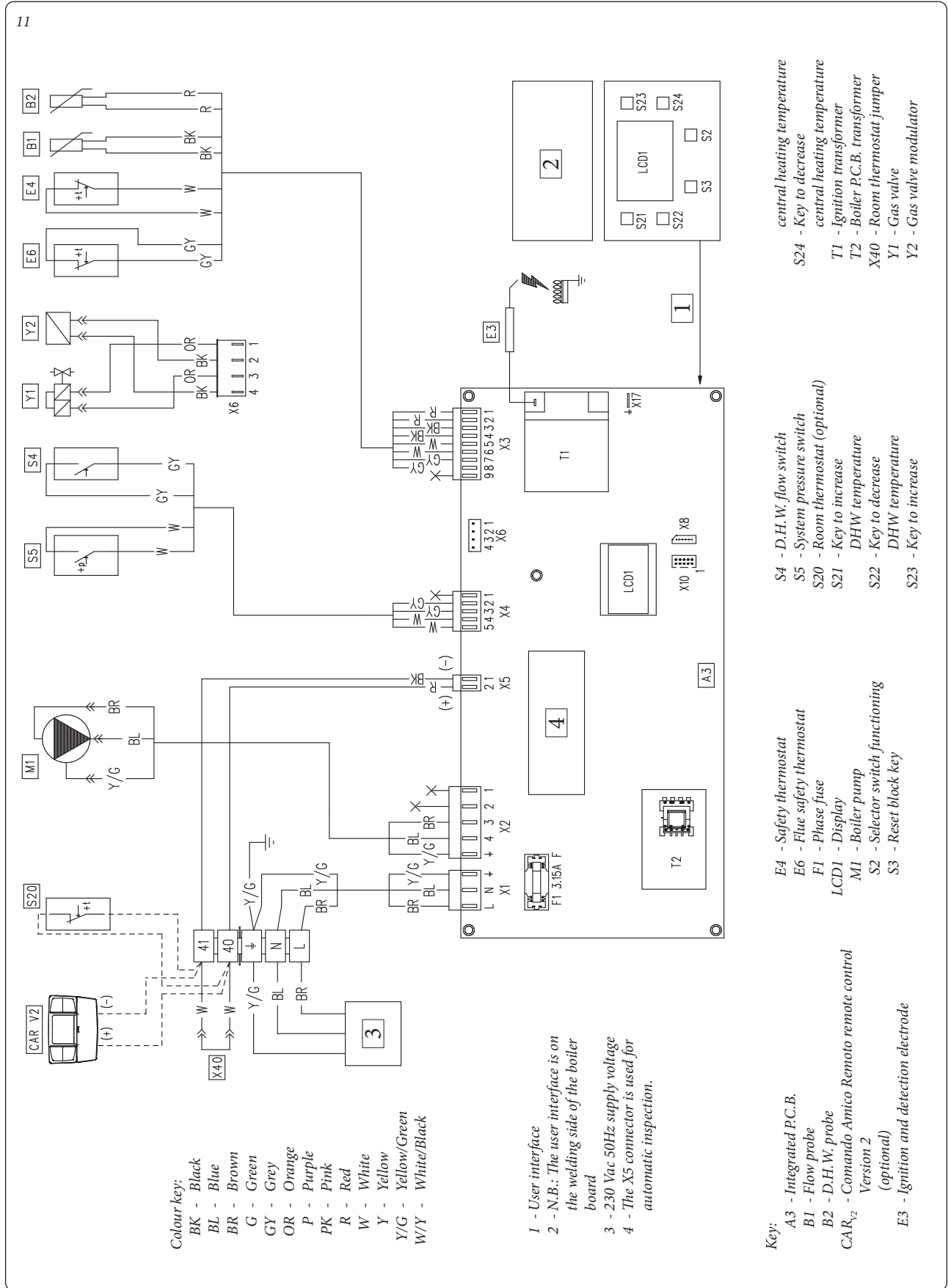

Comando Amico Remoto^{v2}: the boiler is set-up for the application of the Comando Amico Remoto remote control ^{v2} (CAR^{v2}) or of the Mini CRD, which must be connected to clamps 40

and 41, by observing polarity and eliminating jumper X40.

Room thermostat: the boiler is set-up for the application of the Room Thermostat (S20) which

must be connected to clamps 40 and 41 and by eliminating jumper X40.

NOTE: the user interface is on the welding side of the boiler board.

3.3 TROUBLESHOOTING

NOTE: maintenance operations must be carried out by an authorised company (e.g. Authorised After-Sales Technical Assistance Service).

- Smell of gas. Caused by leakage from gas circuit pipelines. Check sealing efficiency of gas intake circuit.
- Irregular combustion (red or yellow flame). When the burner is dirty or the boiler lamellar pack is blocked. Clean the burner or the lamellar pack.
- Frequent activation of the temperature overload thermostat. It can depend on the lack of water in the boiler, little water circulation in the system or blocked pump. Check on the pressure gauge that the system pressure is within established limits. Check that the radiator valves are not closed and also the functionality of the pump.
- The boiler produces condensate. This can be caused by obstructions of the chimney or flues with height or section not proportioned to the boiler. It can also be determined by functioning at boiler temperatures that are excessively low. In this case, make the boiler run at higher temperatures.
- Frequent interventions of the chimney safety thermostat. This can be caused by obstructions in the fumes circuit. Check the flue. The flue may be obstructed or by height or section not suitable for the boiler. Ventilation may be insufficient (see room ventilation point).
- Presence of air in the system. Check opening of the special air vent valve cap (*Fig. 7*). Make sure the system pressure and expansion vessel pressure values are within the set limits; the pressure value for the expansion vessel must be 1.0 bar, and system pressure must be between 1 and 1.2 bar.
- Ignition block and Chimney block. See *Par. 2.5*.
- Poor water flow: if, as a result of limestone (calcium and magnesium), the domestic hot water system does not work properly, contact a qualified company for descaling e.g. Authorised After-Sales Technical Service. Descaling must be carried out on the domestic hot water side of the bithermal heat exchanger in accordance with good practice. To preserve integrity and efficiency of the heat exchanger, a non corrosive descaler must be used. Cleaning must be carried out without the use of tools which can damage the heat exchanger.

INSTALLER

USER

MAINTENANCE TECHNICIAN

SIT 845 GAS valve

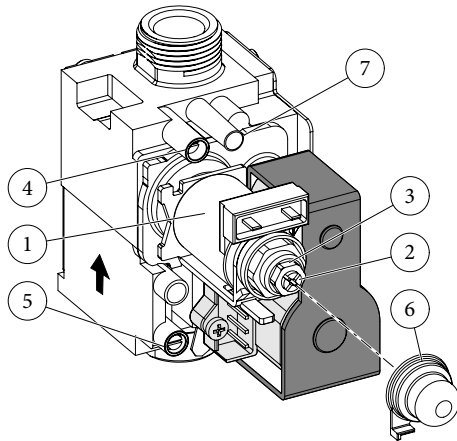

VK 8105 M GAS valve

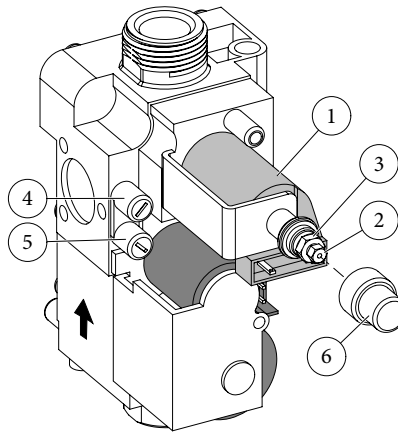

Key:

- 1 - Coil
- 2 - Minimum output adjustment screws
- 3 - Maximum output adjustment nut
- 4 - Outlet pressure point gas valve
- 5 - Gas valve inlet pressure point
- 6 - Protection hood
- 7 - Pressure regulator connection (PR)

12

3.4 CONVERTING THE BOILER TO OTHER TYPES OF GAS.

If the boiler has to be converted to a different gas type to that specified on the data nameplate, request the relative conversion kit for quick and easy conversion.

The gas conversion operation must be carried out by an authorised company (e.g. Authorised Technical After-Sales Service).

To convert to another type of gas the following operations are required:

- remove the voltage from the appliance;
- replace the main burner injectors, making sure to insert the special seal rings supplied in the kit, between the gas manifold and the injectors;
- apply voltage to the appliance;
- select, using the boiler key, the gas parameter type (P01) and select (nG) in the case of methane supply or (LG) in the case of LPG supply and save it;
- adjust the boiler nominal heat output;
- adjust the boiler nominal heat output in domestic hot water phase;
- adjust the boiler nominal heat output in heating phase (para. 3.7);
- adjust (eventually) the maximum heating power (para. 3.7);
- seal the gas flow rate devices (if adjusted);
- after completing conversion, apply the sticker, present in the conversion kit, near the data-plate. Using an indelible marker pen, delete the data relative to the old type of gas.

These adjustments must be made with reference to the type of gas used, following that given in the table (Par. 3.17).

3.5 CHECKS FOLLOWING CONVERSION TO ANOTHER TYPE OF GAS.

After making sure that conversion was carried out with a nozzle of suitable diameter for the type of gas used and the settings are made at the correct pressure, check that:

- there is no flame in the combustion chamber;
- the burner flame is not too high or low and that it is stable (does not detach from burner);
- the pressure testers used for calibration are perfectly closed and there are no leaks from the gas circuit.

N.B.: all boiler adjustment operations must be carried out by a qualified company (e.g. Authorised After-Sales Assistance). Burner adjustment must be carried out using a differential "U" or digital type pressure gauge connected to the gas valve outlet pressure point (part. 4 Fig. 12), keeping to the pressure value given in the table (Par. 3.17) according to the type of gas for which the boiler is prepared.

3.6 POSSIBLE ADJUSTMENTS.

- Adjustment of boiler nominal thermal heat output.

- Activate the chimney sweep function. (Ref. Par. 3.9) in DHW, making sure that the maximum boiler output is reached (on the display "99" is to be displayed).

- From the brass nut (Part. 3 Fig. 12) adjust the boiler nominal output, observing the maximum pressure values stated in the tables (Par. 3.17) depending on the type of gas.

- By turning in a clockwise direction the heating potential increases and in an anti-clockwise direction it decreases.

- Adjust the boiler minimum heat output in the domestic hot water phase (Part. 2 Fig. 12).

N.B.: only proceed after having calibrated the nominal pressure.

Adjustment of the minimum thermal input is obtained by operating on the cross plastic screws (2) on the gas valve maintaining the brass nut blocked (3);

- press the button 4 (Fig. 8) up to reach the minimum boiler output (on the display "00" is to be displayed). The pressure to which the boiler minimum power must be adjusted, must not be lower than that stated in the tables (par. 3.17) depending on the type of gas.

NOTE: to adjust the gas valve, remove the plastic cap (6); after adjusting, refit the cap.

- Adjustment of the boiler minimum heat output in heating phase.

NOTE: only proceed after having calibrated the minimum domestic hot water pressure.

To adjust the minimum heat output during the heating phase, change parameter (5), increasing the value the pressure increases, reducing it the pressure drops.

- The pressure to which the boiler minimum heat output must be adjusted, must not be lower than that stated in the tables (Par. 3.17).

3.7 PROGRAMMING THE P.C.B.

The boiler is prepared for possible programming of several operation parameters. By modifying these parameters as described below, the boiler can be adapted according to specific needs.

To access the programming phase, proceed as follows (Fig. 8):

- press buttons (1) and (2) for 5 about seconds until the programming mode is accessed on the display;
- Using keys (3) and (4), select the parameter to be changed indicated in the following table:
- adjust the corresponding value consulting the table using keys (5) and (6): first pressure of buttons displays the current value;
- confirm the value set by pressing the Reset button (1) for about 5 seconds. Only the displayed value is saved.

Note: 2 minutes after no button is touched will automatically cancel the operation or by pressing buttons (1) and (2) simultaneously for about 5 seconds. Modified but not confirmed values are to be restored to the value preceding the modification.

Id Parameter	Parameter	Description	Range (ref. 9 Fig. 8)	Default
P00	Solar panels selection	The setting of this function is used to set the boiler in order to function with the use of solar panels. By setting the parameter P0 in "solar"on mode, the switching off of the burner is correlated to the adjustment of the domestic hot water temperature. In OFF mode, the burner is switched off at maximum value.	on - oF	oF
P01	Gas type selection	The setting of this function is used to adjust the boiler so that it can operate with the correct type of gas	nG - Methane LG - LPG	Set according to the gas being used
P02	Heating switch-on delay request from room thermostat and remote control.	The boiler is set to switch-on 3 seconds after the request. In the event of particular systems (e.g. area systems with motorised thermostatic valves etc.) it may be necessary to delay ignition	00 - 20 (00 = 3 seconds 01 = 30 seconds 02 = 60 seconds 20 = 600 seconds)	00
P03	Function anti-leakage	This function reduces the heating temperature to 57°C in the case that domestic hot water circulation is detected in the heating mode.	on - oF	oF
P04	Domestic hot water post circulation function	With the post-circulation function active after domestic hot water withdrawal, the pump remains on for 2.5 seconds in winter time and 1.5 seconds in summer time to reduce the formation of limestone.	on - oF	on
P05	Minimum CH output	The boiler also has electronic modulation that adapts the boiler potentiality to the effective heating demand of the house. Then the boiler works normally in a variable gas pressure field between the minimum heating output and the maximum heating output depending on the system's heating load.	00 - 70 %	Set according to factory inspection
P06	Maximum CH output	NOTE: the boiler is produced and calibrated in the central heating phase at nominal output. Approximately 10 minutes are needed to reach the nominal heat output, which can be changed using the parameter (P08). NOTE: the selection of the "Minimum heating output" and "Maximum heating output" parameters, in presence of a heating request, allows boiler ignition and power supply of the modulator with current equal to the value of the respective set value.	00 - 99 (99 = 100%)	99
P07	Central heating ignitions timer	The boiler has electronic timing, which prevents the burner from igniting too often in central heating mode	01 - 20 01 = 30 seconds 02 = 60 seconds 20 = 600 seconds	06
P08	Central heating ramp timer	In the ignition phase, the boiler performs an ignition ramp in order to arrive at the maximum nominal power set (P06).	01 - 20 01 = 30 seconds 02 = 60 seconds 20 = 600 seconds	20
P09	Boiler type	Not used on this model.	01	01
P10	Power ignition	Not used on this model.	- - -	- - -
P11	Minimum heating setting	Defines the minimum flow temperature	35 - 80 °C	35 °C

P12	Maximum heating setting	Defines the maximum flow temperature	35 - 80 °C	80°C
P13	Temperature gradient	Change the insufficient circulation intervention value (E27)	00 - 15 (0 = Function deactivated)	11
P14	Pump functioning	The pump can function in two ways: oF intermittent: in "winter" mode, the circulator is managed by the room thermostat or by the remote control. on continuous: in "winter" mode the circulator is always powered and is therefore always in operation.	oF - on	oF
P15	Gas valve calibration	Not used on this model.	---	---
P16	Valve check	Not used on this model.	---	---
P17	Solar delay	The boiler is set to switch-on immediately after a request for DHW. In the case of coupling with a solar storage tank positioned upstream from the boiler, it is possible to compensate the distance between the storage tank and the boiler in order to allow the water to reach the boiler. Set the time necessary to verify that the water is hot enough not to start the boiler.	00 - 60 (00 = Function deactivated) 01 - 60 seconds	00
P18	Display lighting	Establishes the display lighting mode: 00 = (Off) the display lights on if buttons are pressed (time out = 15 seconds). 01 = (Auto) equal to 00, it also lights on to indicate the flame presence. 02 = (On) always on.	00 - 02	01
P19	Flow off temperature increase (Central heating)	Increases the flow off temperature at ignition only in the first 30 seconds.	on - oF	on

3.8 AUTOMATIC SLOW IGNITION FUNCTION WITH TIMED RAMP DELIVERY.

In the ignition phase the P.C.B. carries out an increasing gas delivery ramp (with pressure values that depend on the type of gas selected) with preset duration. This prevents every calibration or precision adjustment of the boiler ignition phase in any conditions of use.

3.9 "CHIMNEY SWEEP" FUNCTION.

When activated, this function forces the boiler at max. output (P06) for 15 minutes.

In this state all adjustments are excluded and only the temperature safety thermostat and the limit thermostat remain active. To activate the chimney sweep function, press the Reset key for at least 5 seconds. Its activation is indicated by the flashing symbols (Part. 8 and 11 Fig. 8). This function allows the technician to check the combustion parameters. After the checks disable the function, switching the boiler off and then on again or simply by pressing the reset button for about 5 seconds (Part. 1 Fig. 8).

The heating power can be set to P06 and P05 by pressing buttons (3 or 4). The power can be changed by one percentage point by pressing buttons (5 or 6).

If you wish to run the "chimney sweep" function in D.H.W., open a D.H.W. tap after switching the burner on.

Attention: ensure a sufficient DHW flow, in order to avoid high temperatures of the water.

The boiler power can be set to 0% and 100% by pressing buttons (3 or 4). The power can be changed by one percentage point by pressing buttons (5 or 6).

Note: the display of the boiler power percentage alternates with the display of the temperature read by the flow probe.

3.10 HEATING TIMER.

The Nike Star 24 4E boiler has an electronic timing device that prevents the burner from igniting too often in the heating phase. The boiler is supplied as per standard with a timer adjusted at 3 minutes. To adjust the timer values, follow instructions for parameter settings by selecting parameter (P7) and set it with one of the values indicated on the relative table.

3.11 PUMP ANTI-BLOCK FUNCTION.

In the "summer" functioning mode (☀) the boiler has a function that starts the pump at least once every 24 hours for 30 seconds in order to reduce the risk of the pump becoming blocked due to prolonged inactivity.

In the "winter" functioning mode (❄) the boiler has a function that makes the pump start at least once every 3 hours for 30 seconds.

3.12 DOMESTIC HOT WATER CIRCUIT ANTI-EXTRUDER FUNCTION.

This function reduces the heating temperature to 57°C if the domestic hot water circulation is detected in the heating mode. The function can be enabled using parameter (P3).

3.13 RADIATORS ANTIFREEZE FUNCTION.

If the system return water is below 4°C, the boiler starts up until reaching 42°C.

3.14 P.C.B. PERIODICAL SELF-CHECK.

During functioning in central heating mode or with boiler in standby, the function activates every 18 hours after the last boiler check/power supply. In case of functioning in domestic hot water mode the self-check starts within 10 minutes after the end of the withdrawing in progress, for duration of approx. 10 seconds.

NOTE: during self-check, the boiler remains off, including signalling.

3.15 CASING REMOVAL.

To facilitate boiler maintenance the casing can be completely removed as follows (Fig. 13):

- Remove the plugs from the cover (1) by pulling them to you as shown by the arrows.
- Undo the 2 front screws (2) and the 2 lower screws (3) which fasten the casing (4).
- Pull the casing (4) towards yourself and up at the same time to detach it from the upper hooks.

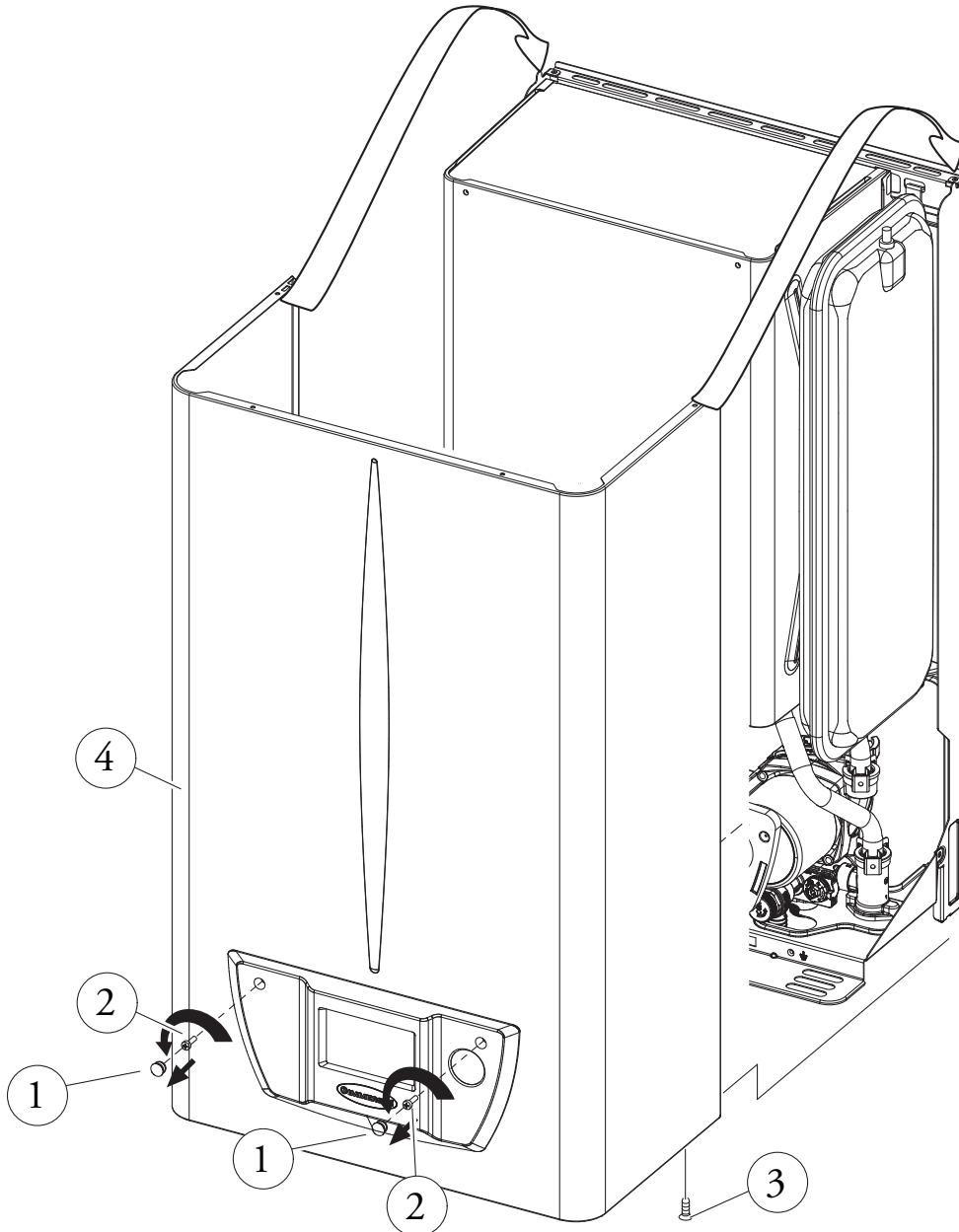

INSTALLER

USER

MAINTENANCE TECHNICIAN

3.16 YEARLY APPLIANCE CHECK AND MAINTENANCE.

The following checks and maintenance should be performed at least once a year.

- Clean the flue side of the heat exchanger.
 - Clean the burner.
 - Check the correct positioning, integrity and cleanliness of the detection and ignition electrode; remove any oxide present.
 - Visually check the draught-breaker/anti-wind device for deterioration or corrosion.
 - Check correct lighting and operation.
 - Ensure correct calibration of the burner in domestic water and heating phases.
 - Check correct operation of control and adjustment devices and in particular:
 - system control thermostat intervention;
 - domestic hot water control thermostat intervention.
 - Check sealing efficiency of gas circuit and the internal system.
 - Check the intervention of the device against no gas ionisation flame control. Intervention time must be less than 10 seconds.
 - Visually check for water leaks or oxidation from/on connections.
 - Visually check that the water safety drain valve is not blocked.
 - Check that, after discharging system pressure and bringing it to zero (read on boiler pressure gauge), the expansion vessel load is at 1.0 bar.
- Check that the system static pressure (with system cold and after refilling the system by means of the filling valve) is between 1 and 1.2 bar.
 - Check visually that the safety and control devices have not been tampered with and/or shorted, in particular:
 - temperature safety thermostat;
 - water pressure switch,
 - flue gas control thermostat.
 - Check the condition and integrity of the electrical system and in particular:
 - electrical power cables must be inside the fairleads;
 - there must be no traces of blackening or burning.

NOTE: in addition to yearly maintenance, you must also check the thermal system and thermal efficiency, with the frequency and procedures that comply with the technical regulations in force.

3.17 VARIABLE HEAT OUTPUT.

NOTE: gas flow rates refer to heating power below a temperature of 15°C and pressure of 1013 mbar. Burner pressure values refer to use of gas at 15°C.

	METHANE (G20)				PROPANE (G31)		
	HEAT THERMAL	GAS FLOW RATE BURNER	PRESS. NOZZLE BURNER		GAS FLOW RATE BURNER	PRESS. NOZZLE BURNER	
			(kW)	(m ³ /h)		(kPa)	(%)
MAX. CH.	23.6	2.78	1.39	100	2.04	3.56	100
MAX. DHW	23.6	2.78	1.39	100	2.04	3.56	100
MIN CH.	9.5	1.16	0.27	9	0.85	0.67	0
MIN. DHW	7.0	0.88	0.16	0	0.64	0.40	0

3.18 COMBUSTION PARAMETERS.

		G20	G31
Gas nozzle diameter	mm	1.30	0.80
Supply pressure	mbar	20	37
Flue flow rate at heating nominal heat output	kg/h	70	70
Flue flow rate at heating minimum heat output	kg/h	62	59
CO ₂ at Nominal Q. O ₂ at Nominal Q.	%	5.30 11.40	6.10 11.60
CO ₂ at Minimum Q. O ₂ at Minimum Q.	%	2.40 16.60	2.90 16.50
CO with 0% O ₂ at Nom./Min. Q.	ppm	80 / 41	87 / 48
NO _x with 0% O ₂ at Nom./Min. Q.	mg/kWh	262 / 159	355 / 180
Flue temperature at nominal output	°C	108	108
Flue temperature at minimum output	°C	89	83

Combustion parameters: measuring conditions of useful efficiency (flow temperature/return temperature= 80 / 60 °C), ambient temperature reference = 15°C.

3.19 TECHNICAL DATA.

Nominal heat input	kW	26.3
Minimum DHW heat input	kW	8.3
CH minimum heat input	kW	11.0
Nominal heat output (useful)	kW	23.6
DHW minimum heat output (useful)	kW	7.0
CH minimum heat output (useful)	kW	9.5
* Efficiency at nominal heat output	%	89.6
* Efficiency at 30% nominal heat output load	%	89.1
Heat loss at case with burner On/Off	%	1.90 / 1.03
Heat loss at flue with burner On/Off	%	6.74 / 0.47
Central heating circuit max. operating pressure	bar	3
Maximum central heating temperature	°C	90
Adjustable central heating temperature	°C	35 - 80
System expansion vessel total volume	l	4.2
Expansion vessel factory-set pressure	bar	1
Appliance water content	l	0.7
Domestic hot water adjustable temperature	°C	35 - 55
Domestic hot water circuit min. pressure (dynamic)	bar	0.3
Domestic hot water circuit max. operating pressure	bar	10
Minimum D.H.W. flow rate	l/min	2.0
Flow rate capacity in continuous duty (ΔT 30°C)	l/min	11.1
Weight of full boiler	kg	25.3
Weight of empty boiler	kg	24.6
Electrical connection	V/Hz	230/50
Nominal power absorption	A	0.30
Installed electric power	W	30
Equipment electrical system protection	IP	X4D
Ambient operating temperature range	°C	0 ÷ 40
Max. flue overheating temperature	°C	180
Boiler flue circuit resistance	Pa	1.3
NO _x class	-	2
Weighted NO _x	mg/kWh	185
Weighted CO	mg/kWh	33
Type of appliance	B11BS	
Category	II2H3P	

- The data relevant to domestic hot water performance refers to a dynamic inlet pressure of 2 bar and an inlet temperature of 15°C; the values are measured directly at the boiler outlet considering that to obtain the data declared mixing with cold water is necessary.

- The max. sound level emitted during boiler operation is < 55dBA. The sound level value is referred to semianechoic chamber tests with boiler operating at max. heat output, with extension of flue gas exhaust system according to product standards.

- * Efficiencies refer to the lower heating value.

INSTALLER

USER

MAINTENANCE TECHNICIAN

3.20 KEY FOR DATA NAMEPLATE.

Md		Code Md	
Sr N°		CHK	Code PIN
Type			
Q _{nw} /Q _n min.	Q _{nw} /Q _n max.	P _n min.	P _n max.
PMS	PMW	D	TM
NO _x Class			

NOTE: the technical data is provided on the data plate on the boiler

ENG	
Md	Model
Code Md	Model code
Sr N°	Serial Number
CHK	Check
Code PIN	PIN code
Type	Type of installation (ref. CEN TR 1749)
Q _{nw} min.	Minimum DHW heat input
Q _n min.	CH minimum heat input
Q _{nw} max.	DHW maximum heat input
Q _n max.	CH maximum heat input
P _n min.	Minimum heat output
P _n max.	Maximum heat output
PMS	Maximum system pressure
PMW	Maximum domestic hot water pressure
D	Specific flow rate
TM	Maximum operating temperature
NO _x Class	NO _x Class

INSTALLER

USER

MAINTENANCE TECHNICIAN

INSTALLER

USER

MAINTENANCE TECHNICIAN

Follow us

Immergas Italia



immergas.com

Immergas Europe S.r.o.
05951 Poprad - Matejovce - SK
Tel. +421.524314311
Fax +421.524314316

Certified company ISO 9001

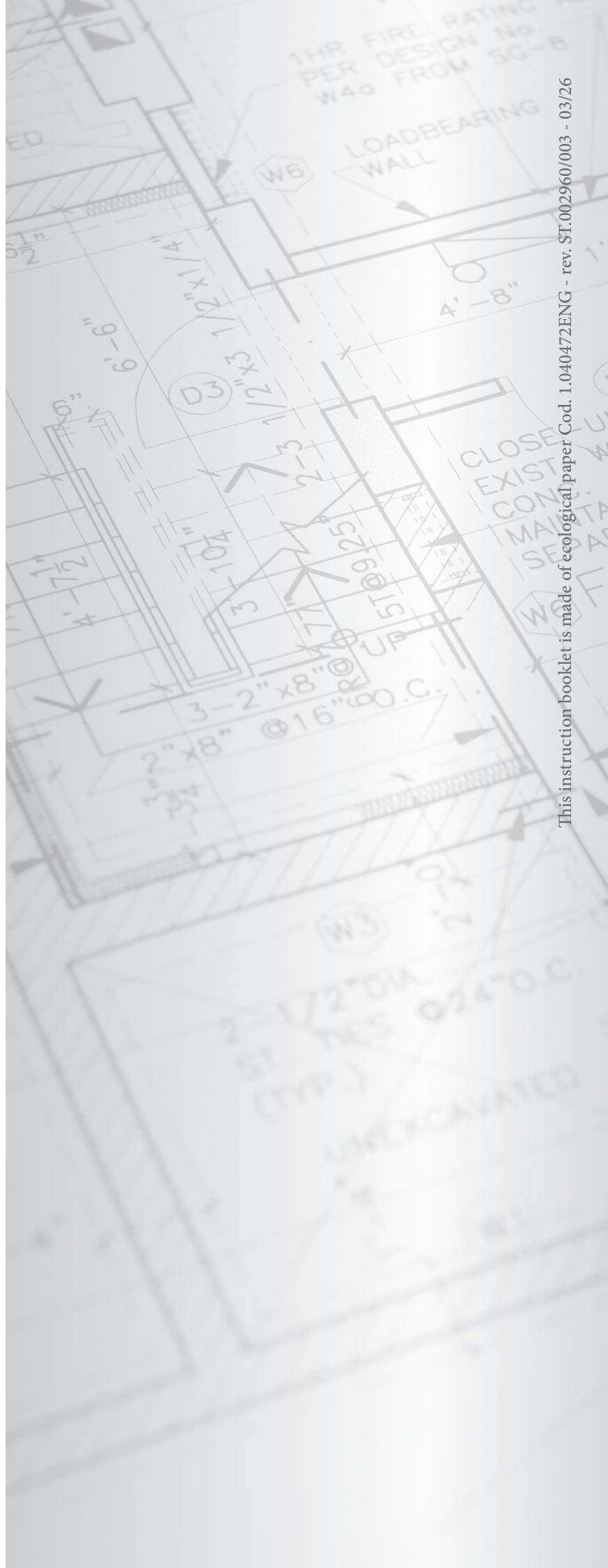

This instruction booklet is made of ecological paper Cod. 1.040472ENG - rev. ST.002960/003 - 03/26