

MAIORS

Instruction and  
recommendation booklet

\*1.048121ENG\*



STD.010252/000



# MAIOR EOLO X 28





## **Dear Customer,**

*Our compliments for having chosen a top-quality Immergas product, able to assure well-being and safety for a long period of time. As an Immergas customer you can also count on a qualified after-sales service, prepared and updated to guarantee constant efficiency of your boiler. Read the following pages carefully: you will be able to draw useful suggestions regarding the correct use of the appliance, the respect of which, will confirm your satisfaction for the Immergas product. For assistance and scheduled maintenance contact Authorised After-Sales centres: they have original spare parts and are specifically trained directly by the manufacturer.*

### **General recommendations**

*All Immergas products are protected with suitable transport packaging.*

*The material must be stored in dry environments protected against bad weather.*

*The instruction book is an integral and essential part of the product and must be consigned to the new user also in the case of transfer or succession of ownership.*

*It must be stored with care and consulted carefully, as all of the warnings provide important safety indications for installation, use and maintenance stages.*

*This instructions manual provides technical information for installing Immergas boilers. As for the other issues related to boiler installation (e.g. safety in the work site, environment protection, injury prevention), it is necessary to comply with the provisions specified in the regulations in force and principles of good practice.*

*In compliance with legislation in force, the systems must be designed by qualified professionals, within the dimensional limits established by the Law. Installation and maintenance must be performed in compliance with the regulations in force, according to the manufacturer's instructions and by an authorised company, which has specific technical expertise in the system sector, as required by Law.*

*Improper installation or assembly of the Immergas appliance and/or components, accessories, kit and devices can cause unexpected problems to people, animals and objects. Read the instructions provided with the product carefully to ensure a proper installation.*

*Maintenance must be carried out by an authorised company. The Authorised After-sales Service represents a guarantee of qualification and professionalism.*

*The appliance must only be destined for the use for which it has been expressly declared. Any other use will be considered improper and therefore potentially dangerous.*

*If errors occur during installation, operation and maintenance, due to non compliance with technical laws in force, standards or instructions contained in this book (or however supplied by the manufacturer), the manufacturer is excluded from any contractual and extra-contractual liability for any damages and the appliance warranty is invalidated.*

**Product not intended for EU countries.**

The manufacturer declines all liability due to printing or transcription errors, reserving the right to make any modifications to its technical and commercial documents without prior notice.

# INDEX

<b>INSTALLER</b>	<b>page</b>	<b>USER</b>	<b>page</b>	<b>MAINTENANCE TECHNICIAN</b>	<b>page</b>
1	Boiler installation.....	2	Use and maintenance instructions.....	3	Boiler start-up (initial check).....
1.1	Installation recommendations.....	2.1	Cleaning and maintenance.....	3.1	Hydraulic diagram.....
1.2	Main dimensions.....	2.2	General warnings.....	3.2	Wiring diagram.....
1.3	Anti-freeze protection.....	2.3	Control panel.....	3.3	Troubleshooting.....
1.4	Gas connection.....	2.4	Using the boiler.....	3.4	Information menu.....
1.5	Hydraulic connection.....	2.5	Troubleshooting.....	3.5	Programming the P.C.B.....
1.6	Electrical connection.....	2.6	Boiler shutdown.....	3.6	Converting the boiler to other types of gas.....
1.7	Remote controls and room chronothermostats (Optional).....	2.7	Restoring central heating system pressure.....	3.7	Checks following conversion to another type of gas.....
1.8	External probe (Optional).....	2.8	System draining.....	3.8	Possible adjustments.....
1.9	Immergas flue systems.....	2.9	Antifreeze protection.....	3.9	Slow automatic ignition function.....
1.10	Outdoor installation in partially protected area.....	2.10	Case cleaning.....	3.10	Chimney sweep" function.....
1.11	Indoor installation.....	2.11	Decommissioning.....	3.11	Pump anti-block function.....
1.12	Flue exhaust to flue/chimney.....			3.12	three-way anti-block function.....
1.13	Ducting of existing flues.....			3.13	Radiators antifreeze function.....
1.14	Flues, chimneys, chimney pots and terminals.....			3.14	P.C.B. periodical self-check.....
1.15	System filling.....			3.15	Solar panels coupling function.....
1.16	Gas system start-up.....			3.16	Yearly appliance check and maintenance.....
1.17	Boiler start-up (ignition).....			3.17	Casing removal.....
1.18	Circulation pump.....			3.18	Variable heat output.....
1.19	Kits available on request.....			3.19	Combustion parameters.....
1.20	Boiler components.....			3.20	Technical data.....
				3.21	Key for data nameplate.....

# 1 BOILER INSTALLATION

## 1.1 INSTALLATION RECOMMENDATIONS.

The Maior Eolo X boiler is designed for wall mounted installation, to heat and produce domestic hot water for domestic use and similar purposes (*when the boiler is connected to an external storage tank unit*).

The place of installation of the appliance and relative Immergas accessories must have suitable features (technical and structural) such to allow (always in safety, efficiency and comfortable conditions):

- installation (according to the provisions of the technical legislation and technical regulations);
- maintenance operations (including scheduled, periodic, routine and special maintenance);
- removal (to outdoors in the place for loading and transporting the appliances and components) as well as their eventual replacement with appliances and/or equivalent components.

In the case of wall installation the wall surface must be smooth, without any protrusions or recesses enabling access to the rear part. They are not designed to be installed on plinths or floors (Fig. 1-1).

By varying the type of installation the classification of the boiler also varies, precisely:

- **Boiler type B<sub>22</sub>** if installed without the 2 intake caps and with the top cover kit
- **Type C boiler** if installed using concentric pipes or other types of pipes envisioned for sealed chamber boilers for air intake and expulsion of flue gas.

Only professionally enabled companies are authorised to install Immergas gas appliances. Installation must be carried out according to regulation standards, current legislation and in compliance with local technical regulations and the required technical procedures.

**Attention:** the manufacturer declines all liability for damages caused by boilers removed from other systems or for any non-conformities of such equipment.

Before installing the appliance, ensure that it is delivered in perfect condition; if in doubt, contact the supplier immediately. Packing materials (staples, nails, plastic bags, polystyrene foam, etc.) constitute a hazard and must be kept out of the reach of children. If the appliance is installed inside or between cabinets, ensure sufficient space for normal servicing; therefore it is advisable to leave clearance of at least 3 cm between the boiler casing and the vertical sides of the cabinet. Leave adequate space above the boiler for possible water and flue removal connections.

Keep all flammable objects away from the appliance (paper, rags, plastic, polystyrene, etc.). Do not place household appliances underneath the boiler as they could be damaged if the safety valve intervenes, if the drain trap is blocked, or if there are leaks from the hydraulic connections; otherwise, the manufacturer cannot be held responsible for any damage caused to the household appliances.

For the aforementioned reasons, we recommend not placing furnishings, furniture, etc. under the boiler.

In the event of malfunctions, faults or incorrect operation, turn the appliance off and contact an authorised company (e.g. the Authorised Technical Assistance centre, which has specifically trained staff and original spare parts). Do not attempt to modify or repair the appliance alone. Failure to comply with the above implies personal responsibility and invalidates the warranty.

### • Installation regulations:

- this boiler can be installed outdoors in a partially protected area. A partially protected area is one in which the appliance is not exposed to the direct action of the weather (rain, snow, hail, etc..).

**N.B.:** *this type of installation is only possible when permitted by the laws in force in the appliance's country of destination.*

- Installation in places with a fire risk is prohibited (for example: garages, closed parking stalls), gas appliances and relative flue ducts, flue exhaust pipes and combustion air intake pipes.
- Installation is prohibited on the vertical projection of cooking hobs.
- Installation is also prohibited in places/environments that constitute common parts of office condominiums such as stairs, cellars, entrance halls, attics, lofts, escape routes, etc. if they are not located inside technical compartments under the responsibility of each individual building and only accessible to the user (for the features of the technical compartments, see the technical standards in force).

**Attention:** wall mounting of the boiler must guarantee stable and efficient support for the generator

*The plugs (standard supply) are to be used only in conjunction with the mounting brackets or fixing template to fix the appliance to the wall; they only ensure adequate support if inserted correctly (according to technical standards) in walls made of solid or semi-hollow brick or block. In the case of walls made from hollow brick or block, partitions with limited static properties, or in any case walls other than those indicated, a static test must be carried out to ensure adequate support.*

**N.B.:** **the hex head screws supplied in the blister pack are to be used exclusively to fix the relative mounting bracket to the wall.**

These boilers are used to heat water to below boiling temperature in atmospheric pressure. They must be attached to a heating system suitable for their capacity and voltage.

They cannot be connected directly to low-temperature systems.

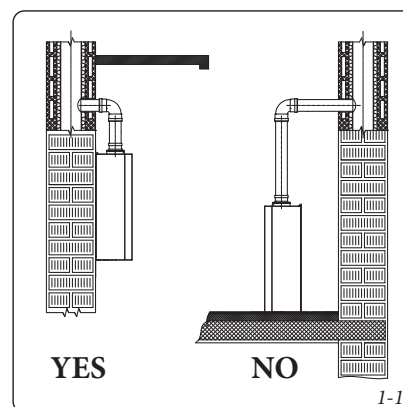

INSTALLER

USER

MAINTENANCE TECHNICIAN

**1.2 MAIN DIMENSIONS.**

Height (mm)	Width (mm)		Depth (mm)	
781	440		340	
CONNECTIONS				
GAS	DOMESTIC HOT WATER		SYSTEM	
	G	AC	AF	R
3/4"*	1/2"	1/2"	3/4"	3/4"

Key:  
 V - Electrical connection  
 G - Gas supply  
 RU - Storage tank unit return (optional)  
 MU - Storage tank unit flow (optional)  
 RR - System filling  
 R - System return  
 M - System flow

\* = the boiler is equipped with a 90° gas cock with 3/4" attachments and Ø18 mm fitting to be welded.

**1.3 ANTIFREEZE PROTECTION.**

**Minimum temperature -5°C.** The boiler is supplied with an antifreeze function as standard that activates the pump and burner when the system water temperature in the boiler falls below 4°C. The antifreeze function is only guaranteed if:

- the boiler is correctly connected to gas and electricity power supply circuits;
- the boiler is powered constantly;
- the boiler is not in "Off" mode;
- the boiler is not in ignition failure block (Par. 2.5);
- the boiler essential components are not faulty.

*In these conditions the boiler is protected against freezing to an ambient temperature of -5 .*

**Minimum temperature -15°C.** If the boiler is installed in a place where the temperature falls below -3°C and in the event there is no gas (or the boiler goes into ignition failure block), the appliance can freeze.

*To prevent the risk of freezing follow the instructions below:*

- protects the central heating circuit from freezing by introducing a top quality anti-freeze liquid into this circuit, which is not noxious to health. The instructions of the manufacturer of this liquid must be followed scrupulously regarding the percentage necessary with respect to the minimum temperature at which the system must be kept. An aqueous solution must be made with potential pollution class of water 2 (EN 1717:2002).

*The materials used for the central heating circuit of Immergas boilers withstand ethylene and propylene glycol based antifreeze liquids (if the mixtures are prepared perfectly).*

For life and possible disposal, follow the supplier's instructions.

- Protect the domestic hot water circuit against freezing by using an accessory that is supplied on request (antifreeze kit) comprising two electric heating elements, the relevant cables and a control thermostat (carefully read the installation instructions contained in the accessory kit pack).

*Boiler antifreeze protection is thus ensured only if:*

- the boiler is correctly connected to electricity power supply circuits;
- the main switch is on;
- the antifreeze kit components are efficient.

*In these conditions the boiler is protected against freezing to temperature of -15°C.*

*The warranty does not cover damage due to interruption of the electrical power supply and failure to comply with that stated on the previous page.*

**N.B.:** if the boiler is installed in places where the temperature falls below 0°C, the heating attachment pipes must be insulated.



#### 1.4 GAS CONNECTION.

Our boilers are designed to operate with methane gas (G20) and LPG. Supply pipes must be the same as or larger than the 3/4" G boiler fitting. Before connecting the gas line, carefully clean inside all the fuel feed system pipes to remove any residue that could impair boiler efficiency. Also make sure the gas corresponds to that for which the boiler is prepared (see boiler data name plate). If different, the appliance must be converted for operation with the other type of gas (see converting appliance for other gas types). The dynamic gas supply (methane or LPG) pressure must also be checked according to the type used in the boiler, which must comply with the technical standards in force, as insufficient levels can reduce generator output and cause malfunctions.

Ensure correct gas cock connection. The gas supply pipe must be suitably dimensioned according to current regulations in order to guarantee correct gas flow rate to the burner even in conditions of maximum generator output and to guarantee appliance efficiency (technical specifications). The coupling system must conform to technical standards in force.

**Fuel gas quality.** The appliance was designed to operate with combustible gas free of impurities; otherwise it is advisable to fit special filters upstream of the appliance to restore the purity of the fuel.

**Storage tanks (in case of supply from LPG depot).**

- New LPG storage tanks may contain residual inert gases (nitrogen) that degrade the mixture delivered to the appliance causing functioning anomalies.
- Due to the composition of the LPG mixture, layering of the mixture components may occur during the period of storage in the tanks. This can cause a variation in the heating power of the mixture delivered to the appliance, with subsequent change in its performance.

#### 1.5 HYDRAULIC CONNECTION.

**Attention:** in order not to void the heat primary exchanger warranty, before making the boiler connections, carefully clean the heating system (pipes, radiators, etc.) with special pickling or de-scaling products to remove any deposits that could compromise correct boiler operation.

A treatment of the heating and water system water is required, in compliance with the technical standards in force, in order to protect the system and the appliance from deposits (e.g. scale), slurry or other hazardous deposits.

Water connections must be made in a rational way using the couplings on the boiler template. The boiler safety valves outlet must be connected to a draining funnel. Otherwise, the manufacturer declines any responsibility in case of flooding if the drain valve cuts in.

**Attention:** the manufacturer declines all liability in the event of damage caused by the inclusion of automatic filling that is not its own brand.

In order to meet the system requirements established by the technical regulation in force in relation to the pollution of drinking water, we recommend installing the IMMERGAS anti-backflow kit to be used upstream of the cold water inlet connection of the boiler. It is also recommended that the heat transfer fluid (e.g. water + glycol) entered in the primary circuit of the boiler (heating circuit), complies with the local regulations in force.

**Attention:** to preserve the duration and the efficiency features of the appliance, in the presence of water whose features can lead to the deposit of scale, installation of the "polyphosphate dispenser" kit is recommended.

#### 1.6 ELECTRICAL CONNECTION.

The "Maior Eolo" boiler has an IPX5D protection rating for the entire appliance. Electrical safety of the appliance is reached only when it is correctly connected to an efficient earthing system as specified by current safety standards.

**Attention:** Immergas S.p.A. declines any responsibility for damage or physical injury caused by failure to connect the boiler to an efficient earth system or failure to comply with the reference standards.

Also ensure that the electrical installation corresponds to maximum absorbed power specifications as shown on the boiler data-plate. Boilers are supplied complete with an "X" type power cable without plug. The power supply cable must be connected to a 230V ±10% / 50Hz mains supply respecting L-N polarity and earth connection; , this network must also have a multi-pole circuit breaker with class III over-voltage category. When replacing the power supply cable, contact a qualified firm (e.g. the Authorised After-Sales Technical Assistance Service). The power cable must be laid as shown (Fig. 1-3).

In the event of mains fuses replacement on the modulation board, use a 3.15A fast fuses. For the main power supply to the appliance, never use adapters, multiple sockets or extension leads.

INSTALLER

USER

MAINTENANCE TECHNICIAN

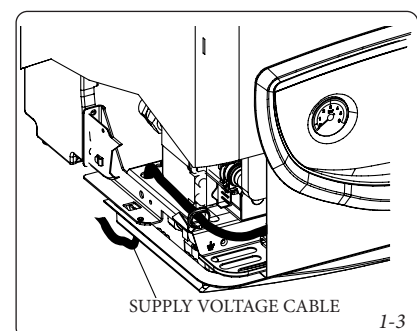

### 1.7 REMOTE CONTROLS AND ROOM CHRONO-THERMOSTATS (OPTIONAL).

The boiler is prepared for the application of room chrono-thermostats or remote controls, which are available as optional kits.

All Immergas chrono-thermostats are connected with 2 wires only. Carefully read the user and assembly instructions contained in the accessory kit.

- On/Off digital Immergas chrono-thermostat (Fig. 1-4). The chrono-thermostat allows:
  - set two room temperature value: one for daytime (comfort temperature) and one for night-time (reduced temperature);
  - set a weekly program with four daily switch on and switch off times;
  - select the required operating mode from the various possible alternatives:
    - manual mode (with adjustable temperature).
    - automatic mode (with set program).
    - forced automatic mode (momentarily changing the temperature of the automatic program).

The chrono-thermostat is powered by two 1.5V LR 6 type alkaline batteries.

- Comando Amico Remoto remote control<sup>V2</sup> (CAR<sup>V2</sup>) (Fig. 1-6) with chrono-thermostat function. In addition to the functions described in the previous point, the CAR<sup>V2</sup> panel enables the user to control all the important information regarding operation of the appliance and the heating system with the opportunity to easily intervene on the previously set parameters, without having to go to where the appliance is installed. The panel is provided with self-diagnosis to display any boiler functioning anomalies. The climate chrono-thermostat incorporated into the remote panel enables the system flow temperature to be adjusted to the actual needs of the room being heated, in order to obtain the desired room temperature with extreme precision and therefore with evident saving in running costs. The CAR<sup>V2</sup> is fed directly by the boiler by means of the same 2 wires used for the transmission of data between the boiler and device.

**Important:** if the system is subdivided into zones using the relevant kit, the CAR<sup>V2</sup> must be used with its climate thermostat function disabled, i.e. it must be set to On/Off mode.

**Comando Amico Remoto Remote Control<sup>V2</sup> or On/Off chrono-thermostat electrical connections (Optional).** *The operations described below must be performed after having removed the voltage from the appliance.* Any thermostat or On/Off environment chrono-thermostat must be connected to clamps 40 and 41 eliminating jumper X40 (Fig. 3-2). Make sure that the On/Off thermostat contact is of the "clean" type, i.e. independent of the mains voltage, otherwise the P.C.B. would be damaged. Any Comando Amico Remoto Remote Control<sup>V2</sup> must be connected to clamps 41 and 44 eliminating jumper X40 on the P.C.B., paying attention not to invert the polarity in the connections (Fig. 3-2).

**Important:** if the Comando Amico Remoto Remote Control<sup>V2</sup> or any other On/Off chrono-thermostat is used, arrange two separate lines in compliance with current regulations regarding electrical systems. No boiler pipes must ever be used to earth the electric system or telephone lines. Ensure elimination of this risk before making the boiler electrical connections.

### 1.8 EXTERNAL PROBE (OPTIONAL).

The boiler is designed for the application of the Room Thermostat (Fig. 1-5) which is available as an optional kit. Refer to the relative instruction sheet for positioning of the external probe. The probe can be connected directly to the boiler electrical system and allows the max. system flow temperature to be automatically decreased when the external temperature increases, in order to adjust the heat supplied to the system according to the change in external temperature. The external probe always acts when connected independently from the presence or type of room thermostat used. The correlation between system flow temperature and outdoor temperature is determined by the position of the selector switch on the boiler control panel according to the curves shown in the diagram (Fig. 1-6). The electric connection of the external probe must be made on clamps 38 and 39 on the boiler P.C.B. (Fig. 3-2).

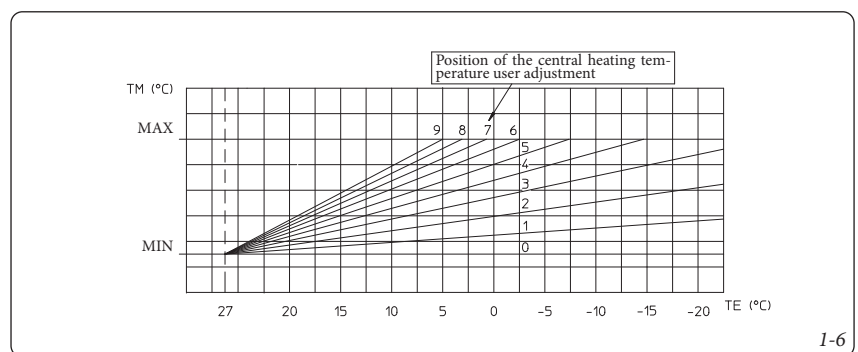
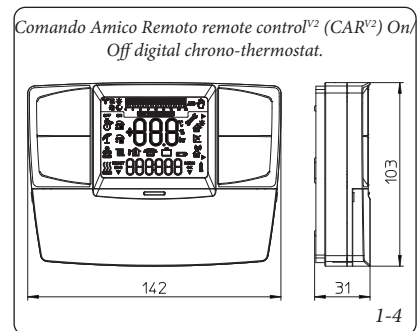
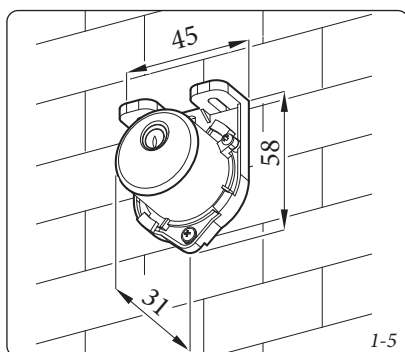



### 1.9 IMMERGAS FLUE SYSTEMS.

Immergas supplies various solutions separately from the boilers regarding the installation of air intake terminals and flue extraction, which are fundamental for boiler operation.

**Attention: The boiler must only be installed together with an original Immergas air intake and flue gas exhaust system, in compliance with the standards in force. This system can be identified by an identification mark and special distinctive marking bearing the note: "not for condensing boilers".**

The flue exhaust pipes must not be in contact with or be near to flammable materials. Moreover, they must not pass through buildings or walls made of flammable material.

See following paragraphs for the detailed description of the kits available

**Positioning of double lip seals.** For correct positioning of lip seals on elbows and extensions, follow the direction of assembly given in figure (Fig. 1-7).

- Resistance factors and equivalent lengths. Each flue component has a *Resistance Factor* based on experimental tests and specified in the table below. The Resistance Factor for individual components is independent from the type of boiler on which it is installed and has a dimensionless size. It is however, conditioned by the temperature of the fluids that pass through the pipe and therefore, varies according to applications for air intake or flue exhaust. Each single component has a resistance corresponding to a certain length in metres of pipe of the same diameter; the so-called *equivalent length*, can be obtained from the ratio between the relative Resistance Factors. *All boilers have an experimentally obtainable maximum Resistance Factor equal to 100.* The maximum Resistance Factor allowed corresponds to the resistance encountered with the maximum allowed pipe length for each type of Terminal Kit. This information allows calculations to be made to verify the possibility of setting up various flue configurations.

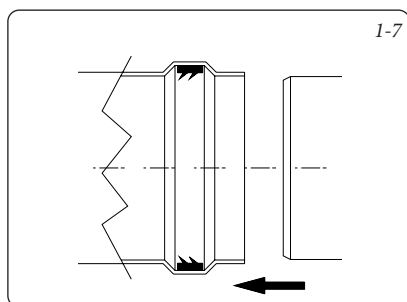

### 1.10 OUTDOOR INSTALLATION IN PARTIALLY PROTECTED AREA.

**N.B.:** a partially protected location is one in which the appliance is not exposed to the direct action of the weather (rain, snow, hail, etc..).

**NOTE:** this type of installation is only possible when permitted by the laws in force in the appliance's country of destination.

- **Configuration type B, open chamber and forced draught.**

The relevant terminal must be used for this configuration (present in the intake kit for the installation in question), which must be placed on the central hole of the boiler (Fig. 1-10). Air intake takes place directly from the environment in which the boiler is installed and flue exhaust in individual flue or to the outside.

The boiler with this type of configuration is classified as type B<sub>22</sub> (in accordance with the technical standards in force).

With this configuration:

- air intake takes place directly from the environment in which the appliance is installed (outside);
- the flue exhaust must be connected to its own individual flue or channeled directly into the external atmosphere.

The technical regulations in force must be respected.

**Flue gas separator adjustment.** For correct functioning of the boiler in configuration with direct air intake it is necessary to regulate the flue gas shutter according to that stated in the relative tables (Fig. 1-11).

- **Coverage kit assembly (Fig. 1-9).** Remove the two plugs and the gaskets present from

the two lateral holes with respect to the central one. Now cover the right intake hole using the relevant plate, fixing it onto the left side using the two supplied screws. Install the Ø 80 outlet flange on the central hole of the boiler, taking care to insert the gasket supplied with the kit and tighten by means of the screws provided. Install the upper cover, fixing it using the 4 screws present in the kit, positioning the relevant gaskets. Engage the 90° Ø 80 bend with the male end (smooth) in the female end (with lip seal) of the Ø 80 flange unit until it stops. Introduce the gasket, making it run along the bend. Fix it using the sheet steel plate and tighten by means of the straps present in the kit, making sure to block the 4 gasket flaps. Fit the male end (smooth) of the exhaust terminal into the the female end of the bend 90° Ø 80, making sure that the relevant wall sealing plate is already fitted; this will ensure hold and joining of the elements making up the kit.

- **Coupling of extension pipes.** To install push-fitting extensions with other elements of the flue, proceed as follows: Couple the pipe or elbow with the male side (smooth) in the female side (with lip seal) to the end stop on the previously installed element. This will ensure sealing efficiency of the coupling.

**Max. length of exhaust duct.** The flue pipe (vertical or horizontal) can be *extended to a max. length of 12 linear metres, using insulated pipes (Fig. 1-28).* To prevent problems of flue gas condensate in the exhaust pipe Ø 80, due to flue gas cooling through the wall, *the length of the pipe (not insulated) must be limited to just 5 m.*

- **Configuration without cover kit (boiler type C).**

By leaving the side plugs fitted, it is possible to install the appliance externally, in partially covered places, without the cover kit. Installation takes place using the Ø 60/100 and Ø 80/125 concentric horizontal intake/ exhaust kits. Refer to the paragraph relative to indoor installation. In this configuration the upper cover kit guarantees additional protection for the boiler. It is recommended but not compulsory.

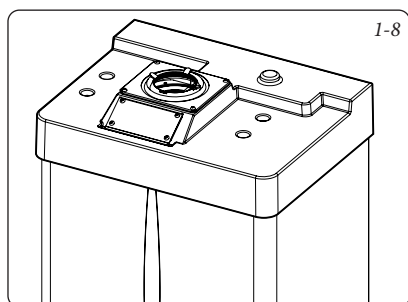

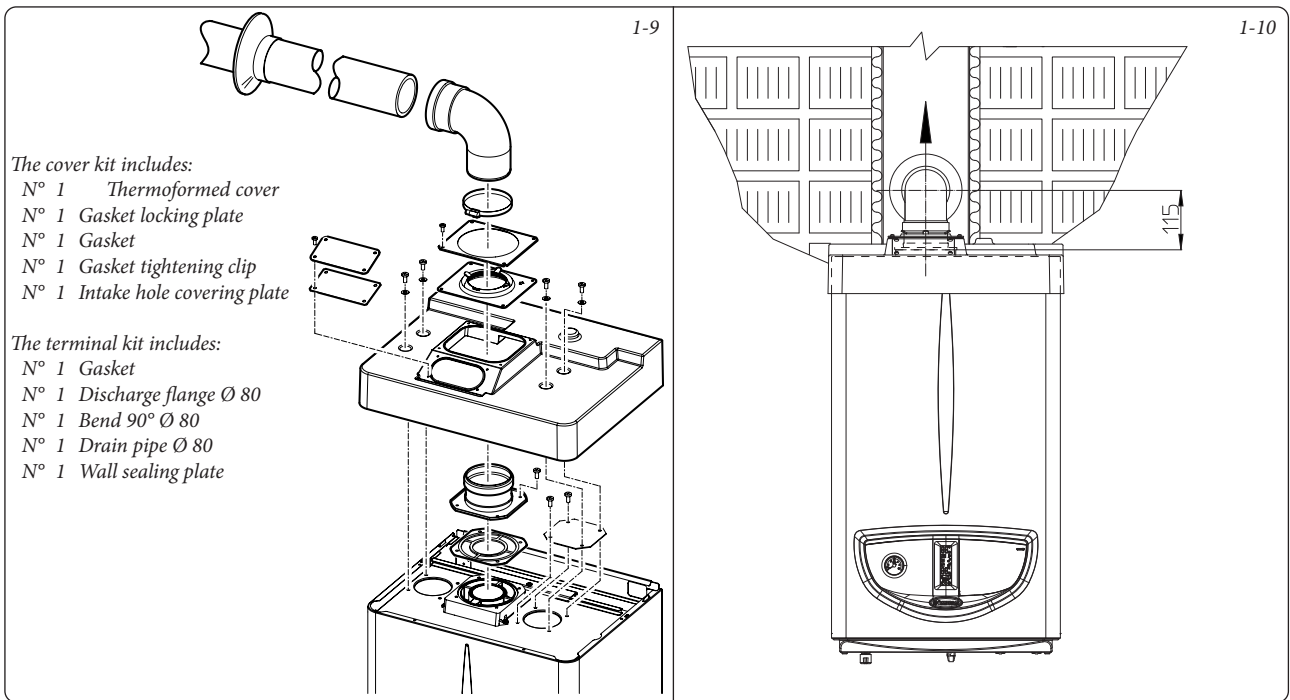

**Flue gas separator adjustment.** For correct functioning of the boiler it is necessary to regulate the flue gas shutter positioned on the air/flue gas sample points (Fig. 1-11).

Adjustment is carried out by loosening the front retainer screw and moving the indicator to the correct position, aligning its value to the horizontal reference. Once adjustment has been performed, tighten the screw to fix the separator. The appropriate adjustment is chosen based on type of pipe and its extension: this calculation can be made using specific tables.

**Intake diaphragm installation.** For correct boiler functioning with Ø 80 separator kits and drain measuring > 1 m a diaphragm must be installed on the sealed chamber intake hole and before the intake pipe (Fig. 1-12). The appropriate diaphragm is chosen based on type of pipe and its maximum extension: this calculation can be made using the tables below:

N.B.: the diaphragms are supplied together with the boiler as standard.

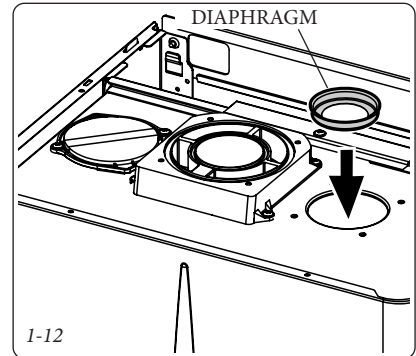
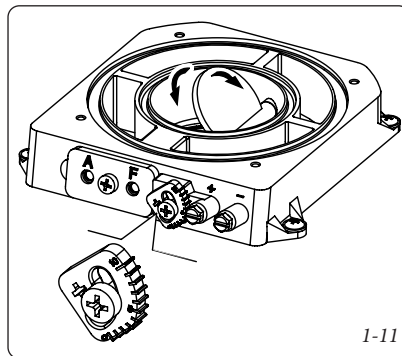









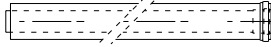

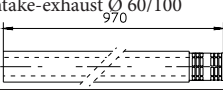

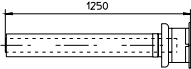
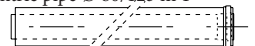
**Shutter regulation table.**

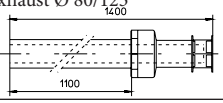
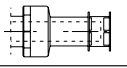
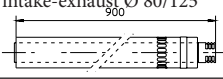
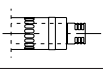
Type of installation (duct length in metres)	Flue gas shutter notch			
	2	4	7	10
Ø 60/100 horizontal concentric kit	-	From 0 to 0.5	From 0.5 to 1.5	From 1.5 to 3.0
Ø 60/100 vertical concentric kit	-	From 0 to 2.2	From 2.2 to 3.7	From 3.7 to 4.7
Ø 80/125 horizontal concentric kit	-	From 0 to 0.5	From 0.5 to 4.6	From 4.6 to 7.4
Ø 80/125 vertical concentric kit	-	From 0 to 5.4	From 5.4 to 9.5	From 9.5 to 12.2
Ø 80 vertical separator kit without bends	*From 0 to 20	*From 20 to 40	**From 0 to 22	**From 22 to 32
Ø 80 horizontal separator kit with two bend	*From 0 to 16	*From 16 to 35	**From 0 to 17	**From 17 to 28
Direct intake kit and Ø 80 drain in B <sub>22</sub> configuration	From 0 to 1	-	From 1 to 12	-

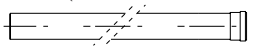
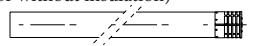
\* These maximum extension values are considered intake with 1 metre exhaust pipe.  
 \*\* These maximum extension values are considered in draining with 1 metre intake pipe and Ø 50 diaphragm on the intake hole.

Tables of Resistance Factors and Equivalent Lengths.

TYPE OF DUCT	Resistance Factor (R)	Equivalent length in m of concentric pipe Ø 60/100	Equivalent length in m of concentric pipe Ø 80/125	Equivalent length of pipe in m Ø 80
Concentric pipe Ø 60/100 m 1 	Intake and Exhaust 16.5	m 1	m 2.8	Intake m 7.1
Exhaust m 5.5				
Concentric bend 90° Ø 60/100 	Intake and Exhaust 21	m 1.3	m 3.5	Intake m 9,1
Exhaust m 7.0				
Concentric bend 45° Ø 60/100 	Intake and Exhaust 16.5	m 1	m 2.8	Intake m 7.1
Exhaust m 5.5				
Terminal complete with concentric horizontal intake-exhaust Ø 60/100 	Intake and Exhaust 46	m 2.8	m 7.6	Intake m 20
Exhaust m 15				
Concentric horizontal intake- exhaust terminal Ø 60/100 	Intake and Exhaust 32	m 1.9	m 5.3	Intake m 14
Exhaust m 10.6				
Concentric vertical intake-exhaust terminal Ø 60/100 	Intake and Exhaust 41.7	m 2.5	m 7	Intake m 18
Exhaust 14				
Concentric pipe Ø 80/125 m 1 	Intake and Exhaust 6	m 0.4	m 1.0	Intake m 2.6
Exhaust m 2.0				
Concentric bend 90° Ø 80/125 	Intake and Exhaust 7.5	m 0.5	m 1.3	Intake m 3.3
Exhaust m 2.5				
Concentric bend 45° Ø 80/125 	Intake and Exhaust 6	m 0.4	m 1.0	Intake m 2.6
Exhaust m 2.0				
Terminal complete with concentric vertical intake-exhaust Ø 80/125 	Intake and Exhaust 33	m 2.0	m 5.5	Intake m 14.3
Exhaust m 11.0				
Concentric vertical intake-exhaust terminal Ø 80/125 	Intake and Exhaust 26.5	m 1.6	m 4.4	Intake m 11.5
Exhaust m 8.8				
Terminal complete with concentric horizontal intake-exhaust Ø 80/125 	Intake and Exhaust 39	m 2.3	m 6.5	Intake m 16.9
Exhaust m 13				
Concentric horizontal intake- exhaust terminal Ø 80/125 	Intake and Exhaust 34	m 2.0	m 5.6	Intake m 14.8
Exhaust m 11.3				
Concentric adapter from Ø 60/100 to Ø 80/125 with condensate trap 	Intake and Exhaust 13	m 0.8	m 2.2	Intake m 5.6
Exhaust m 4.3				
Concentric adapter from Ø 60/100 to Ø 80/125 	Intake and Exhaust 2	m 0.1	m 0.3	Intake m 0.8
Exhaust m 0.6				
Pipe Ø 80 m 1 (with and without insulation) 	Intake 2.3	m 0.1	m 0.4	Intake m 1.0
	Exhaust 3	m 0.2	m 0.5	Exhaust m 1.0
Complete air intake terminal Ø 80 m 1 (with or without insulation) 	Intake 5	m 0.3	m 0.8	Intake m 2.2
Intake terminal Ø 80 Exhaust terminal Ø 80 	Intake 3	m 0.2	m 0.5	Intake m 1.3
	Exhaust 2.5	m 0.1	m 0.4	Exhaust m 0.8
Bend 90° Ø 80 	Intake 5	m 0.3	m 0.8	Intake m 2.2
	Exhaust 6.5	m 0.4	m 1.1	Exhaust m 2.1
Bend 45° Ø 80 	Intake 3	m 0.2	m 0.5	Intake m 1.3
	Exhaust 4	m 0.2	m 0.6	Exhaust m 1.3
Parallel split Ø 80 from Ø 60/100 to Ø 80/80 	Intake and Exhaust 8,8	m 0.5	m 1.5	Intake m 3.8
				Exhaust m 2.9

INSTALLER

USER

MAINTENANCE TECHNICIAN

STD.010252/000

**1.11 INDOOR INSTALLATION.**

- **Type C configuration, sealed chamber and fan assisted.**

**Horizontal intake-exhaust kit Ø 60/100** Kit assembly (Fig. 1-13): install the bend with flange (2) onto the central hole of the boiler inserting the gasket (1) and tighten using the screws included in the kit. Couple the terminal pipe (3) with the male end (smooth) into the female end of the bend (with lip seals) up to the stop; making sure that the internal wall sealing plate and external wall sealing plate have been fitted, this will ensure sealing and joining of the elements making up the kit.

- Coupling extension pipes and concentric elbows Ø 60/100 To install any push-fit extensions with other flue extraction elements, it is necessary to do the following: install the concentric pipe or elbow with the male side (smooth) on the female section (with lip seal) to the end stop on the previously installed element. This will ensure the sealing and joining of the elements correctly.

The Ø 60/100 horizontal intake/exhaust kit can be installed with the outlet at the rear, right side, left side and front.

- Application with rear outlet (Fig. 1-14). The 970 mm pipe length enables routing through a maximum thickness of 710 mm. Normally the terminal must be shortened. Calculate the distance by adding the following values: Part thickness + internal projection + external projection. The minimum indispensable projection values are given in the figure.
- Application with side outlet (Fig. 1-15); Using the horizontal intake-exhaust kit, without the special extensions, enables routing through

a wall thickness of 724 mm with the left side outlet and 646 with the right side outlet.

**NOTE:** when the boiler is installed in areas where very cold temperatures can be reached, a special anti-freeze kit is available that can be installed as an alternative to the standard kit.

- Extensions for horizontal kit. The horizontal intake-exhaust kit Ø 60/100 can be extended up to a *max. horizontal distance of 3000 mm* including the terminal with grid and excluding the concentric bend leaving the boiler. This configuration corresponds to a resistance factor of 100. In this case the special extensions must be requested.

Connection with N°1 extension (Fig. 1-16). Max. distance between vertical boiler axis and external wall is 1855mm.

Connection with N°2 extensions (Fig. 1-17). Max. distance between vertical boiler axis and external wall is 2805mm.

**Horizontal intake-exhaust kit Ø 80/125** Kit assembly (Fig. 1-18): install the bend with flange (2) onto the central hole of the boiler inserting the gasket (1) and tighten using the screws included in the kit. Fit the male end (smooth) of the adapter (3) up to the end stop on the female side of the bend (2) (with lip seal). Fit the Ø 80/125 (4) concentric terminal pipe with the male end (smooth) to the female end of the adapter (3) (with lip gasket) up to the end stop; making sure that the internal and external wall sealing plates have been fitted; this will ensure sealing and joining of the elements making up the kit.

- Extension pipes and concentric elbows Ø 80/125 push-fitting gasket. To install any push-fit extensions with other flue extraction elements, it is necessary to do the following: install the concentric pipe or elbow with the

male side (smooth) on the female section (with lip seal) to the end stop on the previously installed element. This will ensure the sealing and joining of the elements correctly.

**Attention:** if the exhaust terminal and/or concentric extension pipe needs shortening, consider that the internal duct must always protrude by 5 mm with respect to the external duct.

Normally the Ø 80/125 horizontal intake-exhaust kit is used if particularly long extensions are required, the Ø 80/125 kit can be installed with the outlet at the rear, right side, left side or front.

- Extensions for horizontal kit. The Ø 80/125 horizontal intake-exhaust kit can be extended up to a *max. horizontal distance of 7,300 mm* including the terminal with grid and excluding the concentric bend leaving the boiler and the adapter Ø 60/100 in Ø 80/125 (Fig. 1-19). This configuration corresponds to a resistance factor of 100. In this case the special extensions must be requested.

**N.B.:**when installing the pipes, a section clamp with pin must be installed every 3 metres.

- External grid. **N.B.:** for safety purposes, do not obstruct the boiler intake/exhaust terminal, even temporarily.

**Vertical kit with aluminium tile Ø 80/125.** Kit assembly (Fig. 1-20): install the concentric flange (2) on the central hole of the boiler inserting the gasket (1) and tighten using the screws in the kit. Fit the male end (smooth) of the adapter (3) into the female end of the concentric flange (2). Imitation aluminium tile installation. Replace the tile with the aluminium sheet (5), shaping it to ensure that rainwater runs off. Position the fixed half-shell (7) and insert the intake-exhaust pipe (6). Fit the Ø 80/125 concentric terminal pipe with the male end (6) (smooth) to the female

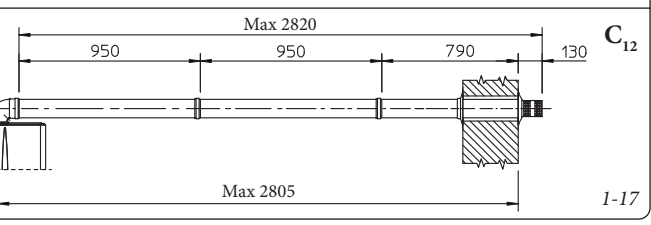
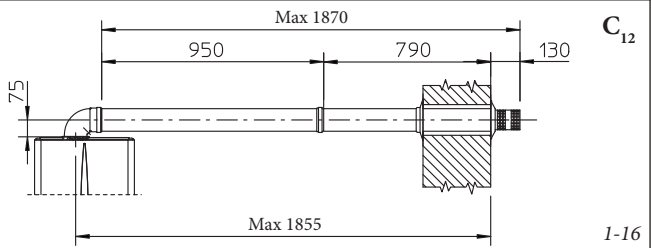
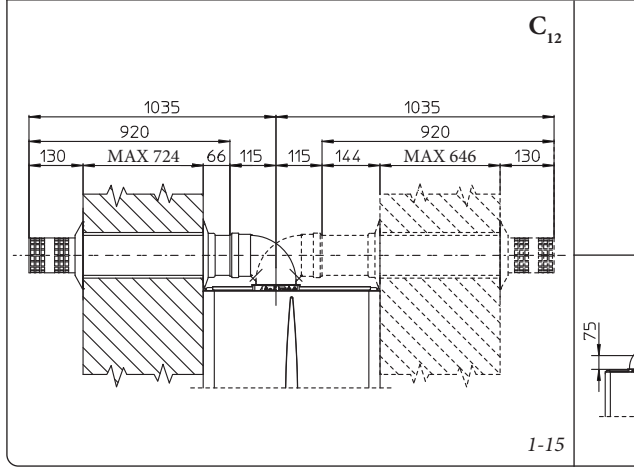
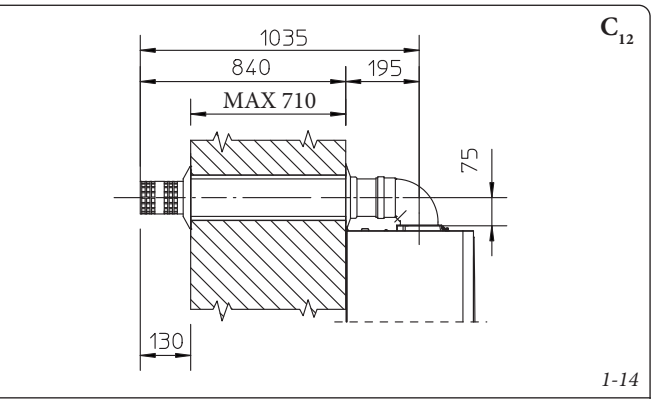
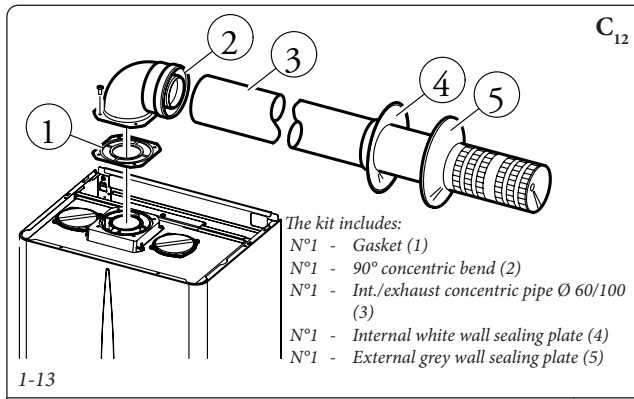

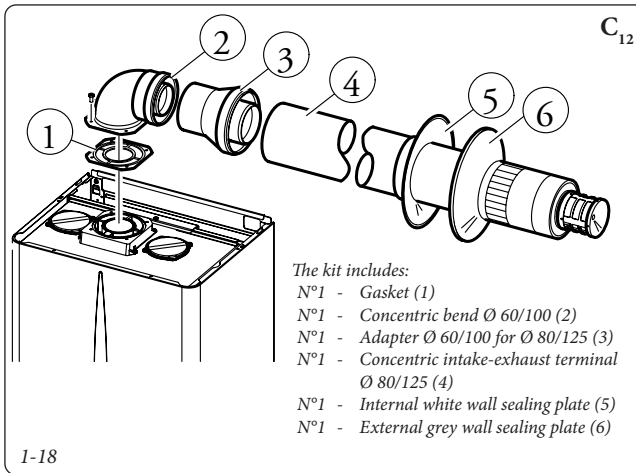

- The kit includes:
- N°1 - Gasket (1)
  - N°1 - Concentric bend Ø 60/100 (2)
  - N°1 - Adapter Ø 60/100 for Ø 80/125 (3)
  - N°1 - Concentric intake-exhaust terminal Ø 80/125 (4)
  - N°1 - Internal white wall sealing plate (5)
  - N°1 - External grey wall sealing plate (6)

1-18

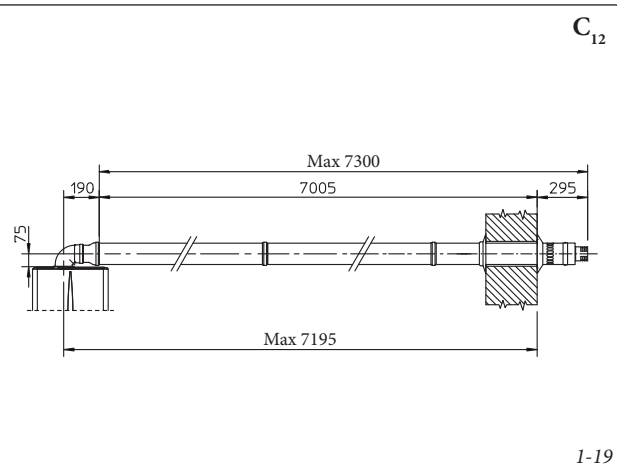

1-19

end of the adapter (3) (with lip gasket) up to the end stop; making sure that the wall sealing plate (4) has been fitted, this will ensure sealing and joining of the elements making up the kit.

- Coupling extension pipes and concentric elbows. To install any push-fit extensions with other flue extraction elements, it is necessary to do the following: install the concentric pipe or elbow with the male side (smooth) on the female section (with lip seal) to the end stop on the previously installed element. This will ensure the sealing and joining of the elements correctly.

**Attention:** if the exhaust terminal and/or concentric extension pipe needs shortening, consider that the internal duct must always protrude by 5 mm with respect to the external duct.

This specific terminal enables flue exhaust and air intake, necessary for combustion, in a vertical direction.

**N.B.:** the Ø 80/125 vertical kit with aluminium tile enables installation on terraces and roofs with a maximum slope of 45% (25°) and the height between the terminal cap and half-shell (374 mm) must always be respected.

The vertical kit with this configuration can be extended to a *max. straight vertical length of*

12200 mm including the terminal (Fig. 1-21). This configuration corresponds to a resistance factor of 100. In this case specific extensions must be requested.

The terminal Ø 60/100 can also be used for vertical exhaust, in conjunction with concentric flange code 3.011141 (sold separately). The height between the terminal cap and half-shell (374 mm) must always be respected.

The vertical kit with this configuration can be extended to a *max. straight vertical length of 4700 mm* including the terminal (Fig. 1-21).

**Separator kit Ø 80/80.** The separator kit Ø 80/80, enables separation of the exhaust flues and air intake pipes according to the diagram shown in the figure. Combustion products are expelled from pipe (S). Air is taken in through pipe (A) for combustion. The intake pipe (A) can be installed either on the right or left hand side of the central exhaust pipe (S). Both ducts can be routed in any direction.

- Kit assembly (Fig. 1-22): install the flange (4) on the central hole of the boiler, interposing the gasket (1) and tighten with the flat-tipped hex screws included in the kit. Remove the flat flange present in the lateral hole with respect to the central one (according to needs) and replace it with the flange (3), positioning the gasket (2) already present in the boiler and tighten using the supplied self-threading screws. Fit the male end (smooth) to the bends (5) in the female end of the flanges (3 and 4). Fit the intake terminal (6) with the male section (smooth) in the female section of the bend (5) up to the end stop, ensuring that the internal and external wall sealing plates are fitted. Fit the exhaust pipe (9) with the male end (smooth) to the female end of the bend (5) up to the stop; making sure that the internal wall sealing plate has been fitted, this will ensure sealing and joining of the elements making up the kit.

- Coupling of extension pipes and elbows. To install any push-fit extensions with other flue extraction elements, it is necessary to do the following: install the pipe or elbow with the male side (smooth) on the female section (with lip seal) to the end stop on the previously installed element. This will ensure the sealing and joining of the elements correctly.

- Installation clearances. Figure 1-23 gives the

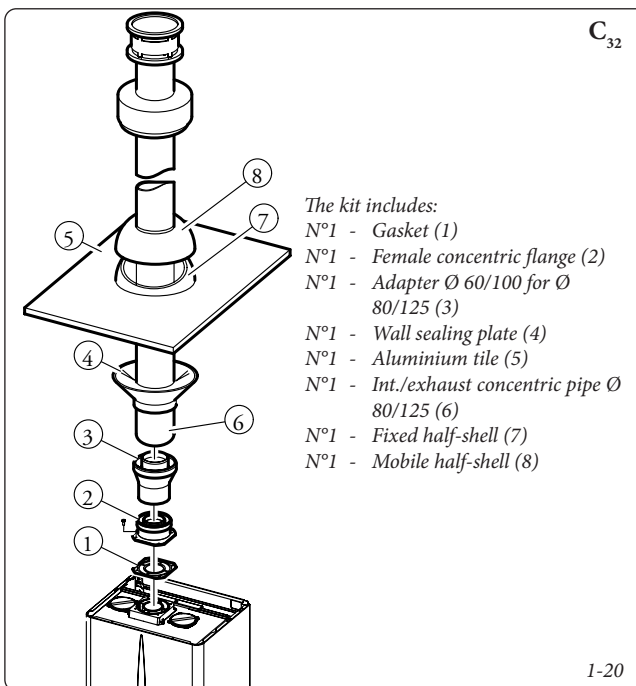

- The kit includes:
- N°1 - Gasket (1)
  - N°1 - Female concentric flange (2)
  - N°1 - Adapter Ø 60/100 for Ø 80/125 (3)
  - N°1 - Wall sealing plate (4)
  - N°1 - Aluminium tile (5)
  - N°1 - Int./exhaust concentric pipe Ø 80/125 (6)
  - N°1 - Fixed half-shell (7)
  - N°1 - Mobile half-shell (8)

1-20

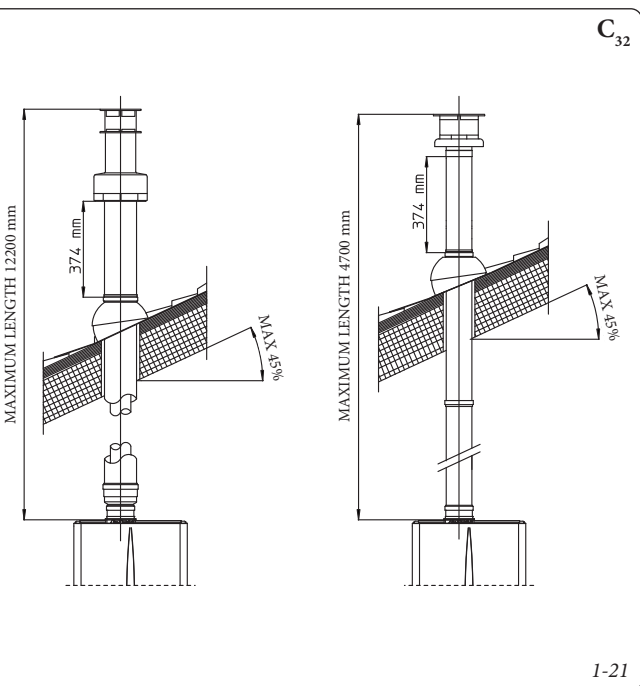

1-21

INSTALLER

USER

MAINTENANCE TECHNICIAN



min. installation space dimensions of the Ø 80/80 separator terminal kit in limited conditions.

- Figure 1-24 shows the configuration with vertical exhaust and horizontal intake.
- Extensions for separator kit Ø 80/80. The max. vertical straight length (without bends) usable for Ø 80 intake and exhaust pipes is 41 metres of which 40 intake and 1 exhaust. This total length corresponds to a resistance factor of 100. The total usable length obtained by summing the Ø 80 intake and exhaust pipe lengths can reach, as a maximum, the values provided in the following table. If *mixed accessories or components are used*, the maximum extension can be calculated by using a resistance factor

for each component or its *equivalent length*. The sum of these resistance factors must not exceed 100.

- Temperature loss in flue ducts. To prevent problems of flue gas condensate in the exhaust pipe Ø 80, due to fume cooling through the wall, *the length of the exhaust pipe must be limited to just 5 metres (Fig. 1-25)*. If longer distances must be covered, use Ø 80 pipes with insulation (see insulated separator kit Ø 80/80 chapter).

**N.B.:** when installing the Ø 80 ducts, a dividing strip with gusset must be installed every 3 metres.

**Insulated separator kit Ø 80/80.** Kit assembly (Fig. 1-26): install the flange (4) on the central hole of the boiler, interposing the gasket (1) and

tighten with the flat-tipped hex screws included in the kit. Remove the flat flange present in the lateral hole with respect to the central one (according to needs) and replace it with the flange (3), positioning the gasket (2) already present in the boiler and tighten using the supplied self-threading screws. Insert and slide cap (6) onto bend (5) from the male side (smooth), and join bends (5) with the male side (smooth) in the female side of flange (3). Fit bend (11) with the male side (smooth) into the female side of flange (4). Fit the male end (smooth) of the intake terminal (7) up to the stop on the female end of the bend (5), making sure you have already inserted the wall sealing plates (8 and 9) that ensure cor-

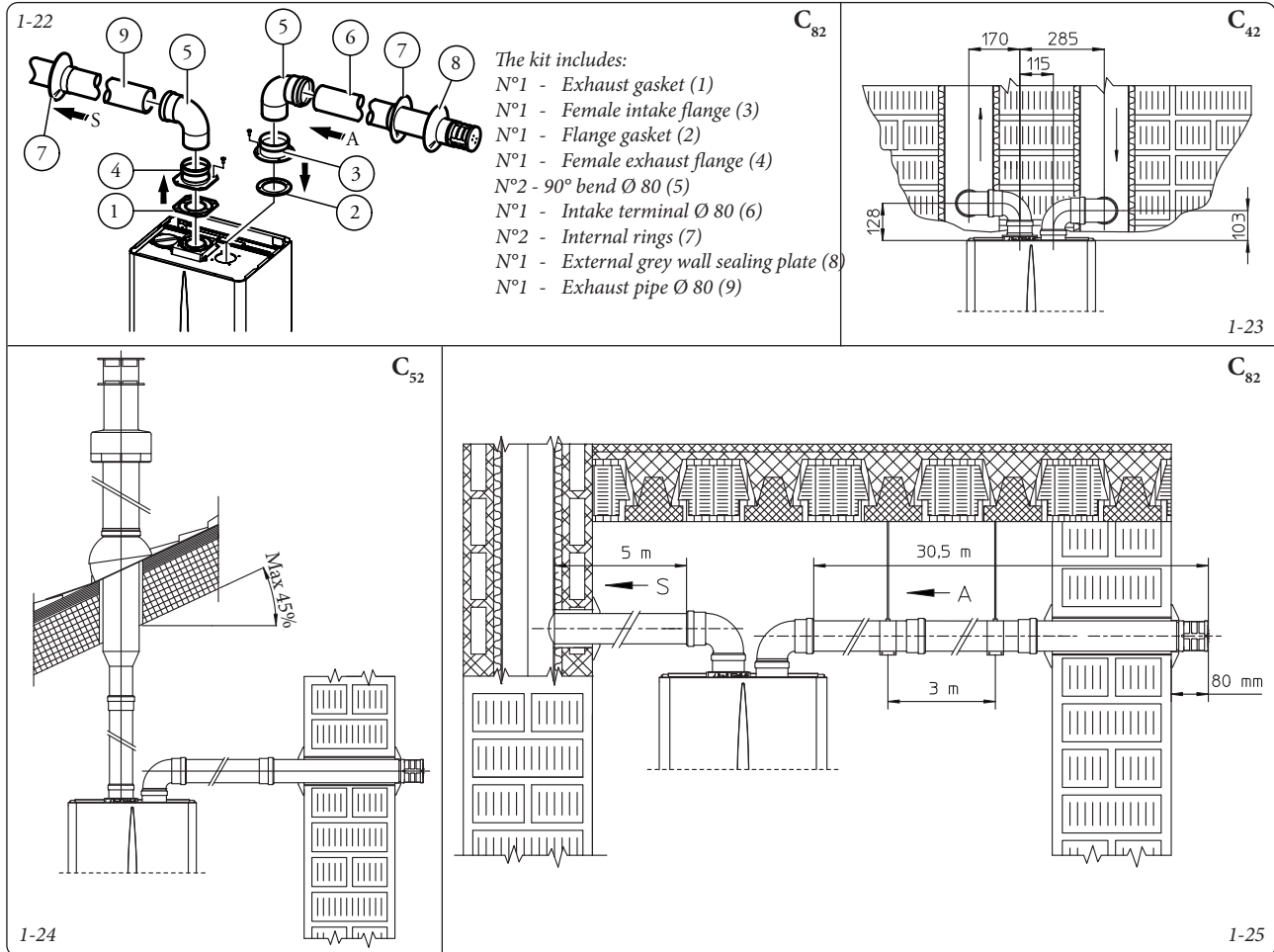

Maximum usable lengths (including intake terminal with grill and two 90° bends)			
NON-INSULATED PIPE		INSULATED PIPE	
Drain (metres)	Intake (metres)	Drain (metres)	Intake (metres)
1	36.0*	6	29.5*
2	34.5*	7	28.0*
3	33.0*	8	26.5*
4	32.0*	9	25.5*
5	30.5*	10	24.0*
* The air intake pipe can be increased to 2.5 metres if the exhaust bend is eliminated, 2 metres if the air intake bend is eliminated, 4.5 metres eliminating both bends.		11	22.5*
		12	21.5*

**Attention:** if the installation requires an extension of the flue to the discharge that exceeds the recommended 12 m, due consideration must be

given to the formation of condensate that may occur inside the pipe and Immergas insulated "Blue Series" flue kits or other flues with equivalent characteristics must be used.



rect installation between pipe and wall, then fix the closing cap (6) on the terminal (7). Join the exhaust pipe (10) with the male side (smooth) in the female side of the bend (11) to the end stop, ensuring that the wall sealing plate (8) is already inserted for correct installation between the pipe and flue.

- Coupling of extension pipes and elbows. To install any push-fit extensions with other flue extraction elements, it is necessary to do the following: install the concentric pipe or elbow with the male side (smooth) on the female section (with lip seal) to the end stop on the previously installed element. This will ensure the sealing and joining of the elements correctly.
- Insulation of separator terminal kit. Whenever there are flue gas condensate problems in the exhaust pipes or on the external surface of the intake pipes, on request Immergas supplies insulated intake-exhaust pipes. Insulation may be necessary on the exhaust pipe, due to excessive loss of temperature of the flue gas on their route. Insulation may be necessary on the intake pipe as the air entering (if very cold) may cause the outside of the pipe to fall below the dew point of the environmental air. The figures (Fig. 1-27 and 1-28) illustrate different applications of insulated pipes.

Insulated pipes are formed of a Ø 80 internal concentric pipe and a Ø 125 external pipe with static air space. It is not technically possible to start with both Ø 80 elbows insulated, as clearances will not allow it. However starting with an insulated elbow is possible by choosing either the intake or exhaust pipe. When starting with the insulated intake bend it must be engaged on its flange until it is taken up to end stop on the flue gas exhaust flange, a situation that takes the two intake flue gas exhaust outlets to the same height.

- Temperature loss in insulated flue ducting. To prevent problems of flue gas condensate in the insulated exhaust pipe Ø 80, due to flue gas cooling through the wall, *the length of the pipe must be limited to 12 metres*. The figure (Fig. 1-28) illustrates a typical insulation application in which the intake pipe is short and the exhaust pipe is very long (over 5 m). The entire intake pipe is insulated to prevent moist air in the place where the boiler is installed, in contact with the pipe cooled by air entering from the outside. The entire exhaust pipe, except the elbow leaving the splitter is insulated to reduce heat loss from the pipe, thus preventing the formation of fume condensate.

N.B.: when installing the insulated pipes, a section clamp with gusset must be installed every 2 metres.

• Configuration type B, open chamber and fan assisted.

The appliance can be installed inside buildings in B mode; in this case, all technical rules, and national and local regulations in force, must be complied with.

- type B open chamber boilers must not be installed in places where commercial, artisan or industrial activities take place, which use products that may develop volatile vapours or substances (e.g. acid vapours, glues, paints, solvents, combustibles, etc.), as well as dusts (e.g. dust deriving from the working of wood, coal fines, cement, etc.), which may be harmful for the components of the appliance and jeopardise operation.
- in configuration type B, the boilers must not be installed in bedrooms, bathrooms or in bedsits.
- The installation of appliances in configuration B is only recommended outdoors (in a partially protected place) or in places that are not lived in and which are permanently ventilated.

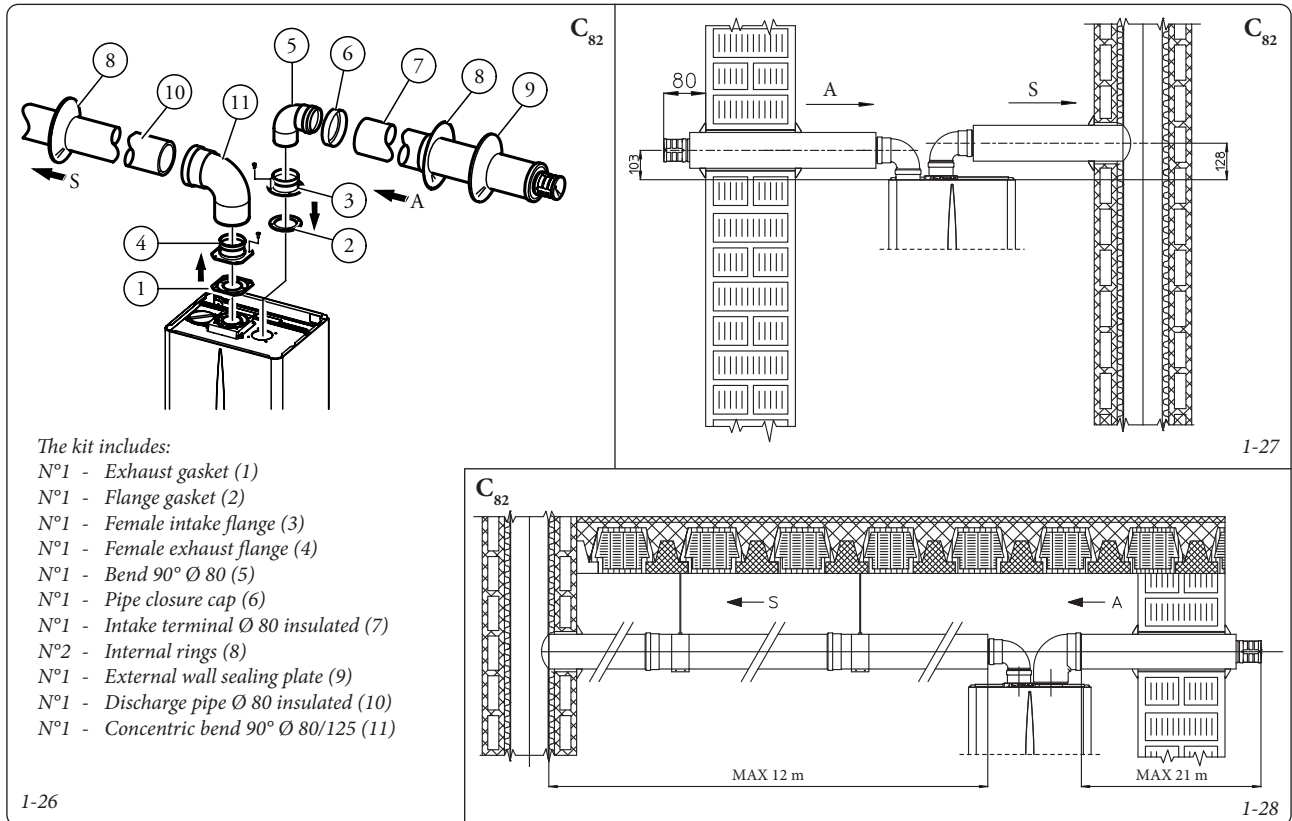

- The kit includes:
- N°1 - Exhaust gasket (1)
  - N°1 - Flange gasket (2)
  - N°1 - Female intake flange (3)
  - N°1 - Female exhaust flange (4)
  - N°1 - Bend 90° Ø 80 (5)
  - N°1 - Pipe closure cap (6)
  - N°1 - Intake terminal Ø 80 insulated (7)
  - N°2 - Internal rings (8)
  - N°1 - External wall sealing plate (9)
  - N°1 - Discharge pipe Ø 80 insulated (10)
  - N°1 - Concentric bend 90° Ø 80/125 (11)

**1.12 FLUE EXHAUST TO FLUE/CHIMNEY.**

The flue exhaust does not necessarily have to be connected to a branched type traditional flue. The flue exhaust, for boiler clots installed in C configuration, can be connected to a special LAS type multiple flue. For B configurations, exhaust is only allowed into individual chimney or directly into the external atmosphere via a suitable terminal. Multiple and combined flues must be specially designed according to the calculation method and requirements of the technical standards in force, by a professionally qualified company. Chimney or flue sections for connection of the flue exhaust pipe must comply with requisites of technical standards in force.

**1.13 DUCTING OF EXISTING FLUES.**

With a specific "ducting system" it is possible to reuse existing flues, chimneys and technical slots to discharge the boiler fumes. Ducting requires the use of ducts declared to be suitable for the purpose by the manufacturer. Follow the installation and user instructions provided by the manufacturer and comply with the technical standards in force.

**1.14 FLUES, CHIMNEYS, CHIMNEY POTS AND TERMINALS.**

The flues, chimneys and chimney pots for the evacuation of combustion products must be in compliance with applicable standards. Chimneys and roof-installed exhaust terminals must comply with the outlet height and with the distance from technical volumes set forth by the technical standards in force.

**Positioning the wall flue exhaust terminals.** The wall flue exhaust terminals must:

- be installed on external perimeter walls of the building;
- be positioned according to the minimum distances specified in current technical standards.

**Combustion products exhaust of fan assisted appliances in open-top closed environments.**

In spaces closed on all sides with open tops (ventilation pits, courtyards etc.), direct flue gas exhaust is allowed for natural or forced draught gas appliances with a heating power range from 4 to 35 kW, provided the conditions as per the current technical standards are respected.

**1.15 SYSTEM FILLING.**

Once the boiler is connected, proceed with system filling via the filling valve (Fig. 2-2). Filling is performed at low speed to ensure release of air bubbles in the water via the boiler and heating system vents.

The boiler has a built-in automatic venting valve on the circulator. *Check if the cap is loose.*

Open the radiator vent valves. Close radiator vent valves when only water escapes from them. Close the filling cock when the boiler pressure gauge indicates approx. 1.2 bar.

**N.B.:** during these operations turn on the circulation pump at intervals, by means of the stand-by/summer winter button (2) positioned on the control panel. *Vent the circulation pump by loosening the front cap and keeping the motor running.* Tighten the cap after the operation.

**1.16 GAS SYSTEM START-UP.**

To start up the system, refer to the technical standard in force: This divides the systems and therefore the start-up operations into three categories: new systems, modified systems, re-activated systems.

In particular, for new gas systems:

- open windows and doors;
- avoid presence of sparks or open flames;
- bleed all air from the pipelines;
- check that the internal system is properly sealed according to the specifications set forth by technical regulations in force;

**1.17 BOILER START-UP (IGNITION).**

In order to issue the Declaration of Conformity required by the law, the following requirements must be fulfilled to commission the boiler (the operations listed below must only be performed by a qualified firm and solely with authorised staff):

- check that the internal system is properly sealed according to the specifications set forth by technical regulations in force;
- make sure that the type of gas used corresponds to boiler settings;

- Check that there are external factors that may cause the formation of fuel pockets;
- switch the boiler on and check correct ignition;
- make sure that the gas flow rate and relevant pressure values comply with those given in the manual (par. 3.18);
- ensure that the safety device intervenes in the event of gas supply failure and check the relative intervention time;
- check activation of the main switch located upstream of the boiler;
- check that the intake/exhaust concentric terminal (if fitted) is not blocked.

The boiler must not be started up even if only one of the checks should be negative.

**N.B.:** only upon completing commissioning by an installer, may an authorised firm carry out an initial inspection of the boiler, which is required to activate the Immergas warranty. The test certificate and warranty is issued to the user.

**1.18 CIRCULATION PUMP.**

The boilers are supplied with a built-in circulation pump with 3-position electric speed control. The boiler does not operate correctly with the circulation pump on first speed. To ensure optimal boiler operation, in the case of new systems (single pipe and module) it is recommended to use the pump at maximum speed. The circulation pump is already fitted with a capacitor.

**Pump release.** If, after a prolonged period of

**Head available to the system.**

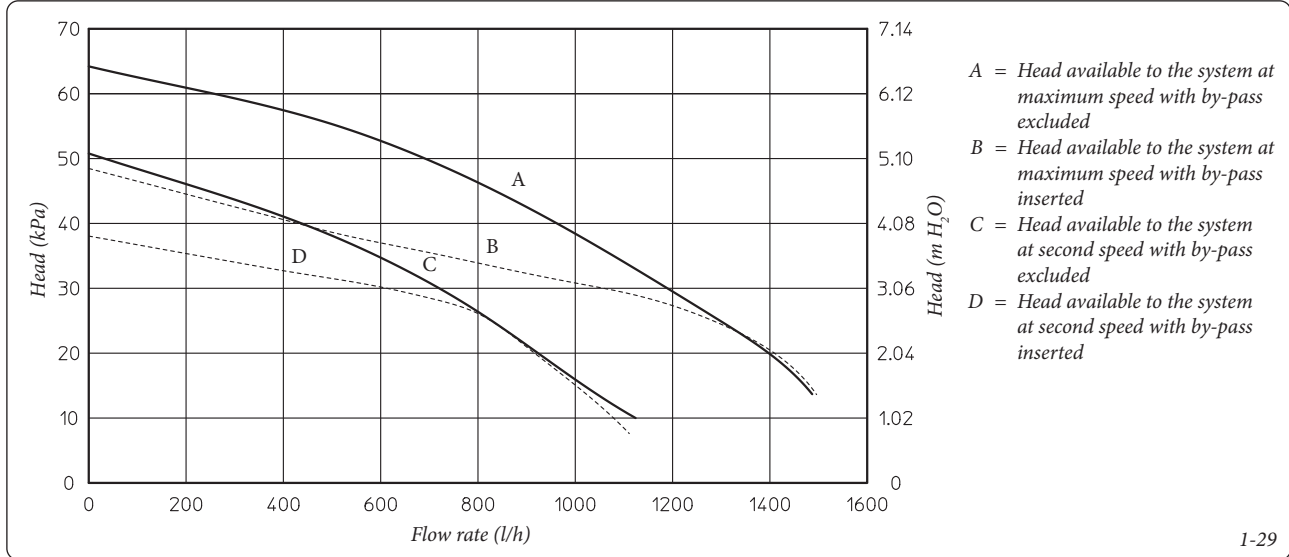

**1.19 KITS AVAILABLE ON REQUEST.**

- System shut off valves kit. The boiler is designed for installation of system interception cocks to be placed on flow and return pipes of the connection assembly. This kit is particularly useful for maintenance as it allows the boiler to be drained separately without having to empty the entire system.
- System zone control unit Kit. If the heating system is to be divided into several zones (**max. three**), in order to interlock them with separate adjustments and to keep water flow rate high for each zone, Immergas supplies zone system kits by request.
- Polyphosphate dispenser kit. The polyphosphate dispenser reduces the formation of lime-scale and preserves the original heat exchange

inactivity, the circulation pump is blocked, unscrew the front cap and turn the motor shaft using a screwdriver. Take great care during this operation to avoid damage to the motor.

**By-pass Regulation (part. 25 Fig. 1-30).** If necessary, the by-pass can be adjusted according to

and domestic hot water production conditions. The boiler is prepared for application of the polyphosphate dispenser kit.

- Cover kit. If installed outdoors in a partially sheltered place with direct air intake, it is compulsory to mount the appropriate top protection cover for the correct functioning of the boiler and to protect it from adverse weather conditions (Fig. 1-6); or, if installed indoors in configuration type B, it is compulsory to mount the appropriate top protection cover along with the flue exhaust kit.

Anti freeze kit with resistance (on request). If the boiler is installed in a place where the temperature falls below -5°C and in the event there is no gas, the appliance can freeze. To prevent freezing of the domestic hot water system, an

system requirements from a minimum (by-pass excluded) to a maximum (by-pass inserted) represented by the graph (Fig. 1-29). Make the regulation using a flat head screwdriver, turn clockwise and insert the by-pass, anti-clockwise it is excluded.

anti freeze kit with an electrical resistance can be fitted from the relative cable and from a control thermostat.

- External storage tank unit coupling kit. If the production of DHW is required as well as room central heating, on request Immergas supplies a kit made up from an external cylinder unit and everything necessary for adaptation of the boiler

The above-mentioned kits are supplied complete with instructions for assembly and use.

1.20 BOILER COMPONENTS.

1- 30

INSTALLER

USER

MAINTENANCE TECHNICIAN

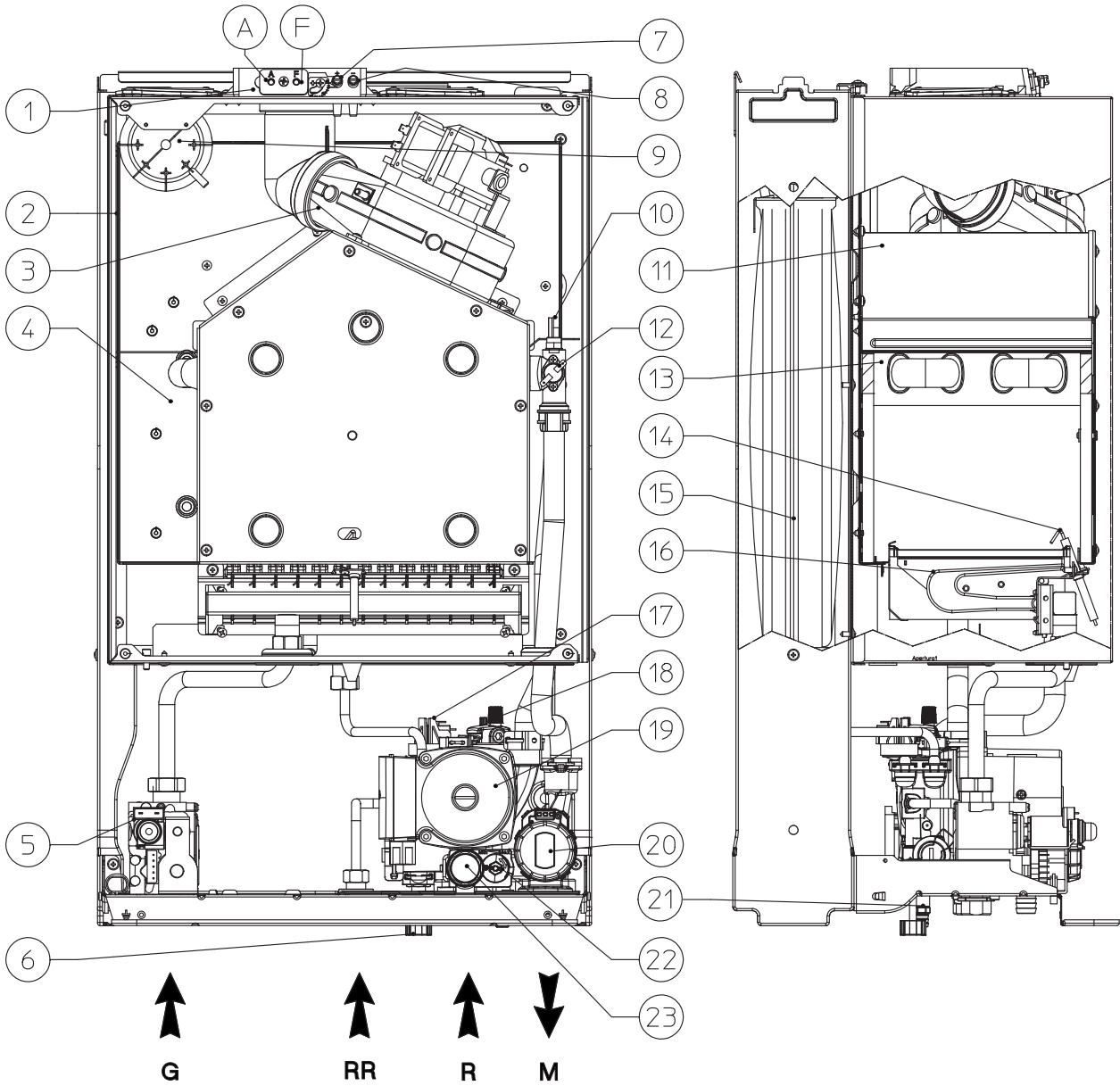

Key:

- 1 - Sample points (air A) - (flue gas F)
- 2 - Sealed Chamber
- 3 - Fan
- 4 - Combustion chamber
- 5 - Gas valve
- 6 - System filling valve
- 7 - Positive signal pressure point
- 8 - Negative signal pressure point
- 9 - Flue pressure switch

- 10 - Flow probe
- 11 - Fumes hood
- 12 - Safety thermostat
- 13 - Primary heat exchanger
- 14 - Ignition and detection electrodes
- 15 - System expansion vessel
- 16 - Burner
- 17 - System pressure switch
- 18 - Vent valve
- 19 - Boiler circulator pump

- 20 - 3-way valve motorised
- 21 - System draining valve
- 22 - By-pass
- 23 - 3 bar safety valve

STD.010252/000

## 2 USE AND MAINTENANCE INSTRUCTIONS

### 2.1 CLEANING AND MAINTENANCE.

**Attention:** to preserve the boiler's integrity and keep the safety features, performance and reliability, which distinguish it, unchanged over time, you must execute maintenance operations on a yearly basis in compliance with what is stated in the relative point at "annual check and maintenance of the appliance", in compliance with national, regional, or local standards in force. We recommend stipulating a yearly cleaning and maintenance contract with your local technician.

### 2.2 GENERAL WARNINGS.

Never expose the wall-mounted boiler to direct vapours from a cooking surface.

Use of the boiler by unskilled persons or children is strictly prohibited.

Do not touch the flue gas exhaust terminal (if present) due to the high temperatures it can reach; For safety purposes, check that the concentric air intake/flue exhaust terminal (if fitted), is not blocked.

If temporary shutdown of the boiler is required, proceed as follows:

- drain the heating system if antifreeze is not used;
- shut-off all electrical, water and gas supplies.

In the case of work or maintenance to structures near ducting or devices for flue extraction and the relative accessories, switch off the appliance and on completion of the operations make sure that an authorised company verifies the efficiency of the ducting or the devices.

Never clean the appliance or connected parts with easily flammable substances.

Never leave containers or flammable substances in the same environment as the appliance.

• **Attenzione:** the use of components involving use of electrical power requires some fundamental rules to be observed:

- do not touch the appliance with wet or moist parts of the body; do not touch when barefoot;
- never pull electrical cables or leave the appliance exposed to weathering (rain, sunlight, etc.);

- the appliance power cable must not be replaced by the user;
- if the cable is damaged, switch off the appliance and solely contact an authorised company to replace it;
- if the appliance is not to be used for a certain period, disconnect the main power switch.

**N.B.:** the temperatures indicated by the display have a tolerance of +/- 3°C due to environmental conditions that cannot be attributed to the boiler.

At the end of its service life, the appliance must not be disposed of like normal household waste nor abandoned in the environment, but must be removed by a professionally authorised company. Contact the manufacturer for disposal instructions.

### 2.3 CONTROL PANEL.

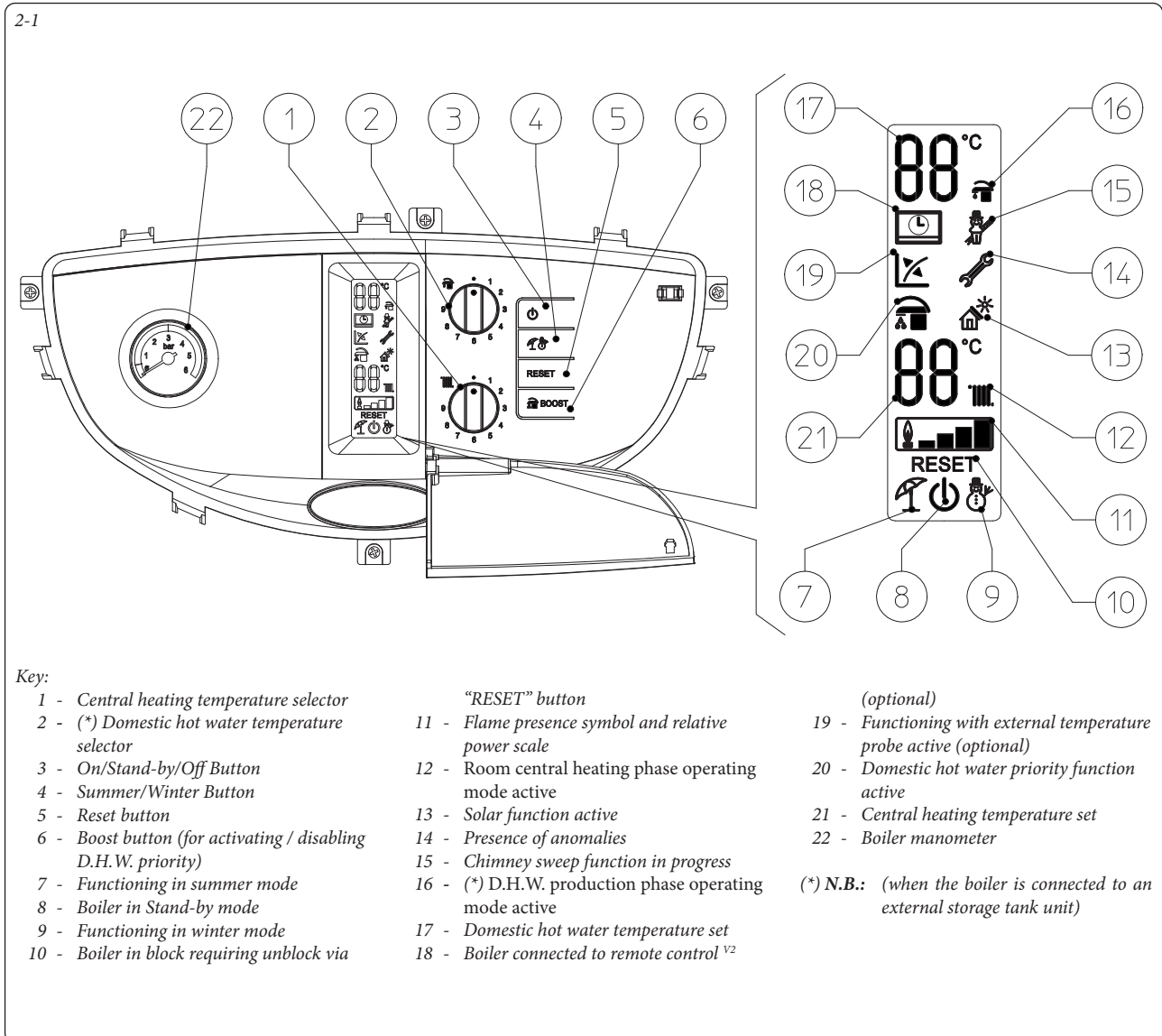





## 2.4 USING THE BOILER.

**Attention:** the Maior Eolo X 28 boiler has been designed to operate as an appliance for room central heating only or, coupled with a specific optional kit, for central heating and the production of DHW. For this reason the boiler control panel has a button to adjust the temperature of DHW, but its operation is only activated by the optional kits that also enable the production of DHW. Without the combination of these specific kits, the operation of this button and all functions referring to the DHW are inhibited.

Before ignition make sure the heating system is filled with water and that the manometer (2) indicates a pressure of  $1 \div 1.2$  bar.

- Open the gas cock upstream from the boiler.
- Press the button (3) until the display switches on. The boiler now returns to the state prior to switch-off.
- If the boiler is in stand-by, press the button (3) again to activate it. If this is not the case, go to the next point.
- Then press the button (4) in sequence and set the boiler in the summer () or winter () position.

• **Summer** (): in this mode the boiler only works to produce DHW (*when the boiler is connected to the external storage tank unit*); the temperature is set via the selector (2) and the relative temperature is shown on the display via the indicator (17).

During a request for DHW the indicator (16) switches on. Upon ignition of the burner, the flame presence indicator (11) with relative power scale switches on and the indicator (17) shows the instant outlet temperature from the primary heat exchanger.

• **Winter** (): in this mode, the boiler works to produce DHW (*when the boiler is connected to the external storage tank unit*) as well as central heating. The temperature of the DHW is always regulated via the selector (2), the heating temperature is regulated via selector (1) and the relative temperature is shown on the display via the indicator (21).

During a request for CH the indicator (12) switches on. Upon ignition of the burner, the flame presence indicator (11) with relative power scale switches on and the indicator (21) shows the instant outlet temperature from the primary heat exchanger. In the central heating phase, if the temperature of the water contained

in the system is sufficient to heat the radiators, the boiler can only function with the activation of the boiler pump (indicator 12 on).

From this moment the boiler functions automatically. With no demand for heat (central heating or domestic hot water production) the boiler goes to "standby" function, equivalent to the boiler being powered without presence of flame. Each time the burner ignites, the relative flame present symbol is displayed (11) with relative output scale.

• **Operation with Comando Amico Remoto<sup>V2</sup> (CAR<sup>V2</sup>) (Optional).** If the CAR<sup>V2</sup> is connected, the () symbol will appear on the display. The boiler regulation parameters can be set via the CAR<sup>V2</sup> control panel and the reset button (5) remains active on the boiler control panel, along with the switch-off button (3) ("off" mode only) and the display where the functioning state is shown.

**Attention:** If the boiler is put into "off" mode, the "ERR>CM" connection error symbol will appear on the CAR<sup>V2</sup>. The CAR<sup>V2</sup> is however powered constantly so as not to lose memorised programs.

• **Solar operating mode** (). This function cannot be activated on this boiler model.

• **Domestic hot water priority function** (). Pressing the Boost button (6) disables the D.H.W. priority function, which is indicated by the symbol (20) switching off on the display. The disabled function keeps the water contained in the storage tank at a temperature of 10°C for 1 hour, giving the functioning priority to room central heating.

**Attention:** in the event of switching to the Stand-by/Off mode, with subsequent ignition (Summer/Winter) the D.H.W. priority function becomes active again.

• **Operation with optional external probe** (). In the case of a system with optional external probe, the boiler flow temperature for room central heating is managed by the external probe depending on the external temperature measured (Par. 1.6). The flow temperature can be modified by selecting the functioning curve via selector (1), selecting a value from "0 to 9" (Fig. 1-6).

With external probe present, the relative

symbol (19) will appear on the display. In the central heating phase, if the temperature of the water contained in the system is sufficient to heat the radiators, the boiler can only function with the activation of the pump.

• **"Stand-by" mode.** Press button (3) until the () symbol appears. The boiler remains active from this moment and the anti-freeze function, pump anti-block function and 3-way and signalling of any anomalies is guaranteed.

**N.B.:** in these conditions the boiler is still powered.

• **"Off" mode.** By holding the button (3) down for 8 seconds, the display switches-off and the boiler is off completely. The safety functions are not guaranteed in this mode.

**IMPORTANT NOTE:** in these conditions the boiler is considered still live even if there are no functions active.

• **Display operation.** The display lights up during the use of the control panel or if the burner is ignited, after 15 seconds of inactivity, the brightness drops until only the active symbols are displayed. The lighting mode can be varied via parameter P2 in the P.C.B. programming menu.



## 2.5 TROUBLESHOOTING.

In the event of an anomaly, it is signalled via the flashing indicator (14) on the boiler display according to the following table.

On the remote control, the error code will be displayed by means of the same numeric code represented according to the following example (e.g. CAR<sup>V2</sup> = Exx).

Error Code	Anomaly signalled	Cause	Boiler status / Solution
01	No ignition block	If room central heating or domestic hot water production is requested, <i>(when the boiler is connected to an external storage tank unit)</i> the boiler does not switch on within the preset time. Upon appliance commissioning or after extended downtime, it may be necessary to eliminate the block.	Press the Reset button (1).
02	Safety thermostat block (overheating), flame control anomaly	During normal operation, if a fault causes excessive overheating internally, the boiler goes into overheating block.	Press the Reset button after cooling (1).
03	Fan anomaly	This occurs if the fan is blocked or if the intake or drain pipes are obstructed.	If normal conditions are restored the boiler restarts without having to be reset (1).
04	Generic boiler P.C.B. anomaly	This occurs when a signal is recognised incorrectly by the boiler P.C.B. microprocessor.	Press the Reset button (1).
05	Flow probe anomaly	The board detects an anomaly on the flow probe.	The boiler does not start (1).
08	Maximum N° of reset	Number of allowed resets that have already performed.	<b>Attention:</b> the anomaly can be reset 5 times consecutively, after which the function is inhibited for at least one hour. One attempt is gained every hour for a maximum of 5 attempts. By switching the appliance on and off the 5 attempts are re-acquired.
10	Insufficient system pressure	Water pressure inside the central heating circuit that is sufficient to guarantee the correct operation of the boiler is not detected.	Check on the boiler pressure gauge (1) that the system pressure is between 1÷1.2 bar and restore the correct pressure if necessary.
11	Flue pressure switch failure	This occurs in the event of an error on the P.C.B. that enables fan start-up incorrectly or in the event of a flue-gas pressure switch fault.	If normal conditions are restored the boiler restarts without having to be reset (1).
12	Storage tank probe anomaly	If the board detects an anomaly on the boiler probe, the boiler cannot produce domestic hot water <i>(when the boiler is connected to an external storage tank unit)</i> .	(1).
15	Configuration error	If the board detects an anomaly or incongruity on the electric wiring, the boiler will not start.	If normal conditions are restored the boiler restarts without having to be reset (1).
20	Parasite flame	This occurs in the event of a leak on the detection circuit or anomaly in the flame control unit.	Press the Reset button (1).
24	Push button control panel anomaly	The board detects an anomaly on the pushbutton panel.	If normal conditions are restored the boiler restarts without having to be reset (1).
27	Insufficient circulation	This occurs if there is overheating in the boiler due to insufficient water circulating in the primary circuit; the causes can be: - low system circulation; check that no shut-off devices are closed on the heating circuit and that the system is free of air (deaerated); - pump blocked; free the pump.	Press the Reset button (1).
31	Loss of remote control communication.	This occurs if an incompatible remote control is connected, or after 1 minute if communication is lost between the boiler and CAR <sup>V2</sup> .	Power cycle the boiler. If the Remote Control is still not detected on re-starting the boiler will switch to local operating mode, i.e. using the controls on the control panel. In this case the "Central heating" mode (1) cannot be activated.
37	Low power supply voltage	This occurs when the power supply voltage is lower than the allowed limits for the correct boiler operation.	If normal conditions are restored the boiler restarts without having to be reset (1).
38	Loss of flame signal	This occurs when the boiler is ignited correctly and the burner flame switches off unexpectedly; a new attempt at ignition is performed and if normal conditions are restored, the boiler does not have to be reset.	If normal conditions are restored the boiler restarts without having to be reset (1).

(1) If the shutdown or fault persists, contact an authorised company (e.g. Authorised Technical After-Sales Service).

INSTALLER

USER

MAINTENANCE TECHNICIAN

STD.010252/000

Error Code	Anomaly signalled	Cause	Boiler status / Solution
43	<b>Block due to loss of continuous flame signal</b>	This occurs if the "Flame signal loss" error occurs 6 consecutive times in 8.5 minutes.	Press the Reset button (1).
44	<b>Block for maximum time, partial gas valve opening</b>	This occurs if the gas valve remains open for longer than required for normal operation, without the boiler switching on.	Press the Reset button (1).

(1) If the shutdown or fault persists, contact an authorised company (e.g. Authorised Technical After-Sales Service).

**2.6 BOILER SHUTDOWN**

For complete boiler switch-off, press the "off" button, disconnect the omnipolar switch outside of the boiler and close the gas cock upstream from the appliance. Never leave the boiler switched on if left unused for prolonged periods.

**2.7 RESTORING CENTRAL HEATING SYSTEM PRESSURE.**

Periodically check the system water pressure. The boiler pressure gauge should read a pressure between 1 and 1.2 bar.

*If the pressure is below 1 bar (with the circuit cool) restore normal pressure via the filling cock located in the lower part of the boiler (Fig. 2-2).*

**N.B.:** close the filling cock after the operation. If pressure values reach around 3 bar the safety valve may be activated.

In this case, remove water from an air vent valve of a radiator until 1 bar is reached or ask for assistance from an authorised company.

If frequent pressure drops should occur, ask an authorised company for assistance to eliminate the possible system leakage.

**2.8 SYSTEM DRAINING.**

To drain the boiler, use the special draining valve (Fig. 2-2).

Before draining, ensure that the filling valve is closed.

**2.9 ANTIFREEZE PROTECTION.**

The boiler has an anti-freeze function that switches on automatically when the temperature falls below 4°C (standard protection to minimum temperature of -5°C). In order to guarantee the integrity of the appliance and the domestic hot water heating system in areas where the temperature falls below zero, we recommend protecting the central heating system with anti-freeze liquid and installing the the Immergas Anti-freeze Kit in the boiler (Par. 1.3). In the case of prolonged inactivity (second case), we also recommend that:

- disconnect the electric power supply;
- the central heating circuit and boiler domestic hot water circuit must be drained. In systems that are drained frequently, filling must be carried out with suitably treated water to eliminate hardness that can cause lime-scale.

**2.10 CASE CLEANING.**

Use damp cloths and neutral detergent to clean the boiler casing. Never use abrasive or powder detergents.

**2.11 DECOMMISSIONING.**

In the event of permanent shutdown of the boiler, contact an authorised company for the suitable procedures and also ensure the electrical, water and fuel supply lines are shut off and disconnected.

**Bottom view.**

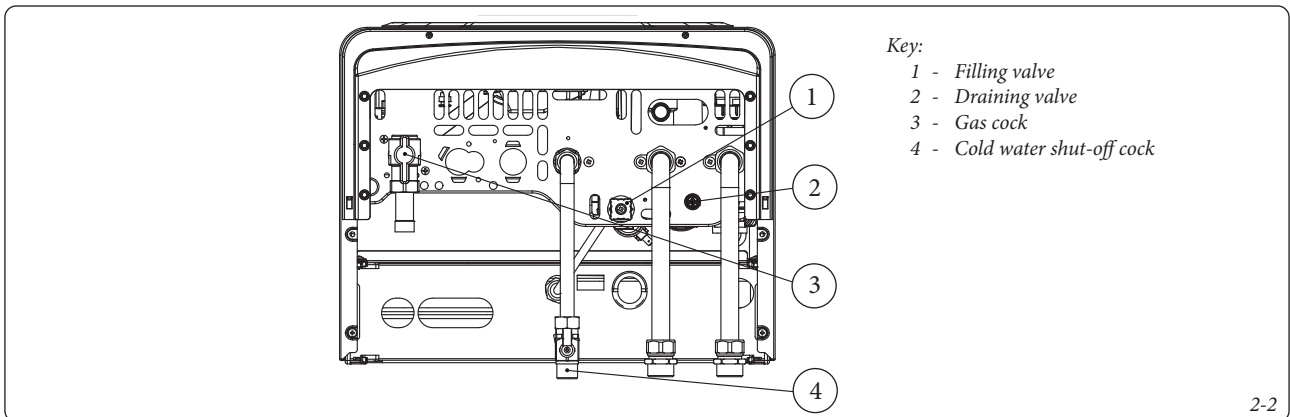

- Key:
- 1 - Filling valve
  - 2 - Draining valve
  - 3 - Gas cock
  - 4 - Cold water shut-off cock

### 3 BOILER START-UP (INITIAL CHECK)

To commission the boiler:

- make sure that the type of gas used corresponds to boiler settings;
- check connection to a 230V-50Hz power mains, correct L-N polarity and the earthing connection;
- make sure the central heating system is filled with water and that the manometer indicates a pressure of 1±1.2 bar.
- make sure the air valve cap is open and that the system is well deaerated;
- switch the boiler on and check correct ignition;
- make sure the gas maximum, intermediate and minimum flow rate and pressure values correspond to those given in the handbook (Par. 3.18);
- make sure the gas supply failure safety device is working, within its relative intervention time;

- check activation of the main switch located upstream of the boiler;
- check that the intake and/or exhaust terminals are not blocked;
- check activation of the “no air” safety pressure switch;
- ensure activation of all adjustment devices;
- seal the gas flow rate regulation devices (if settings are modified);
- check the production of DHW (when the boiler is connected to an *external storage tank unit*);
- check sealing efficiency of water circuits;
- check ventilation and/or aeration of the installation room where required.

If even only a single safety check offers a negative result, do not commission the system.

#### 3.1 HYDRAULIC DIAGRAM.

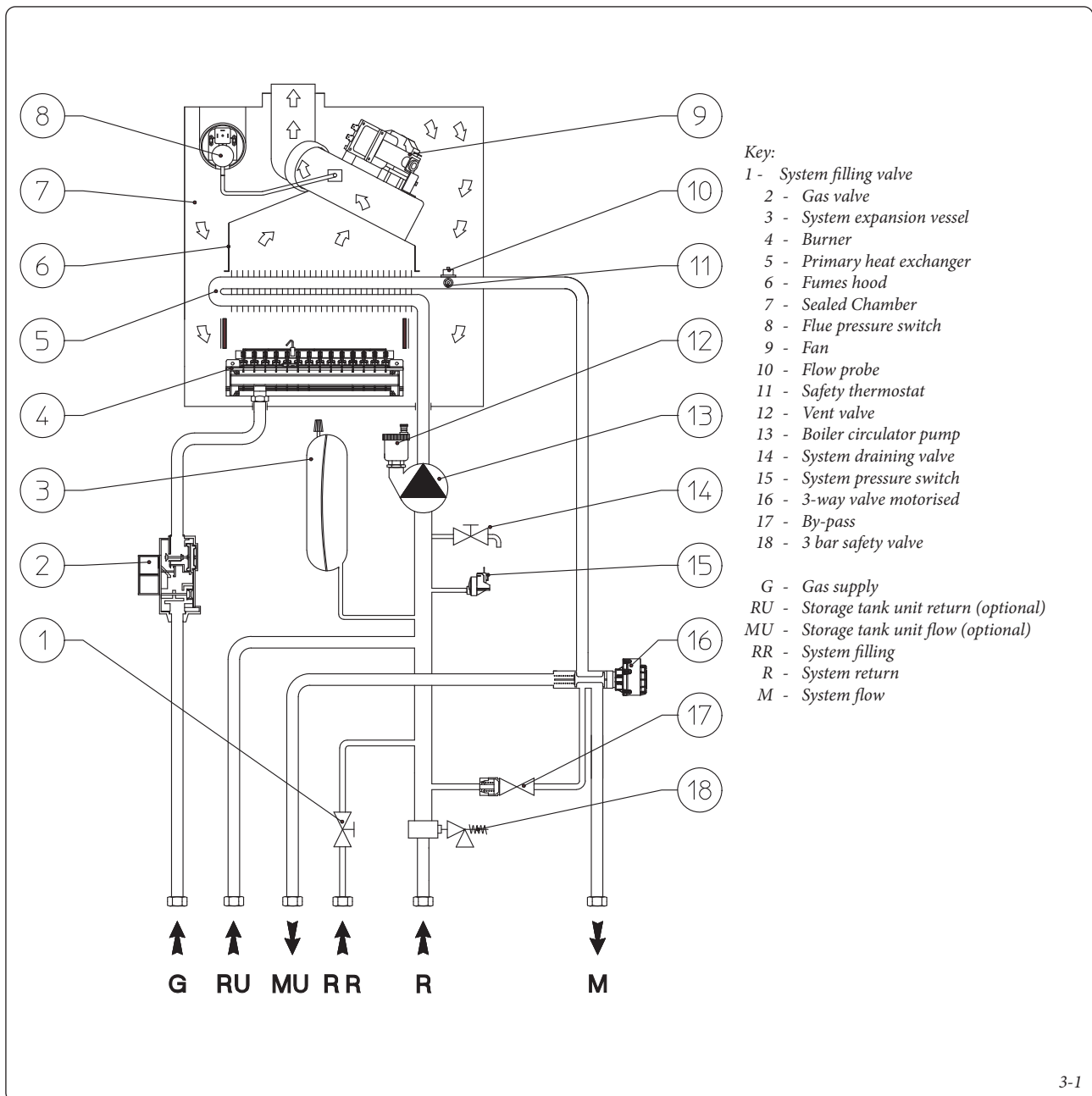

INSTALLER

USER

MAINTENANCE TECHNICIAN

### 3.2 WIRING DIAGRAM.

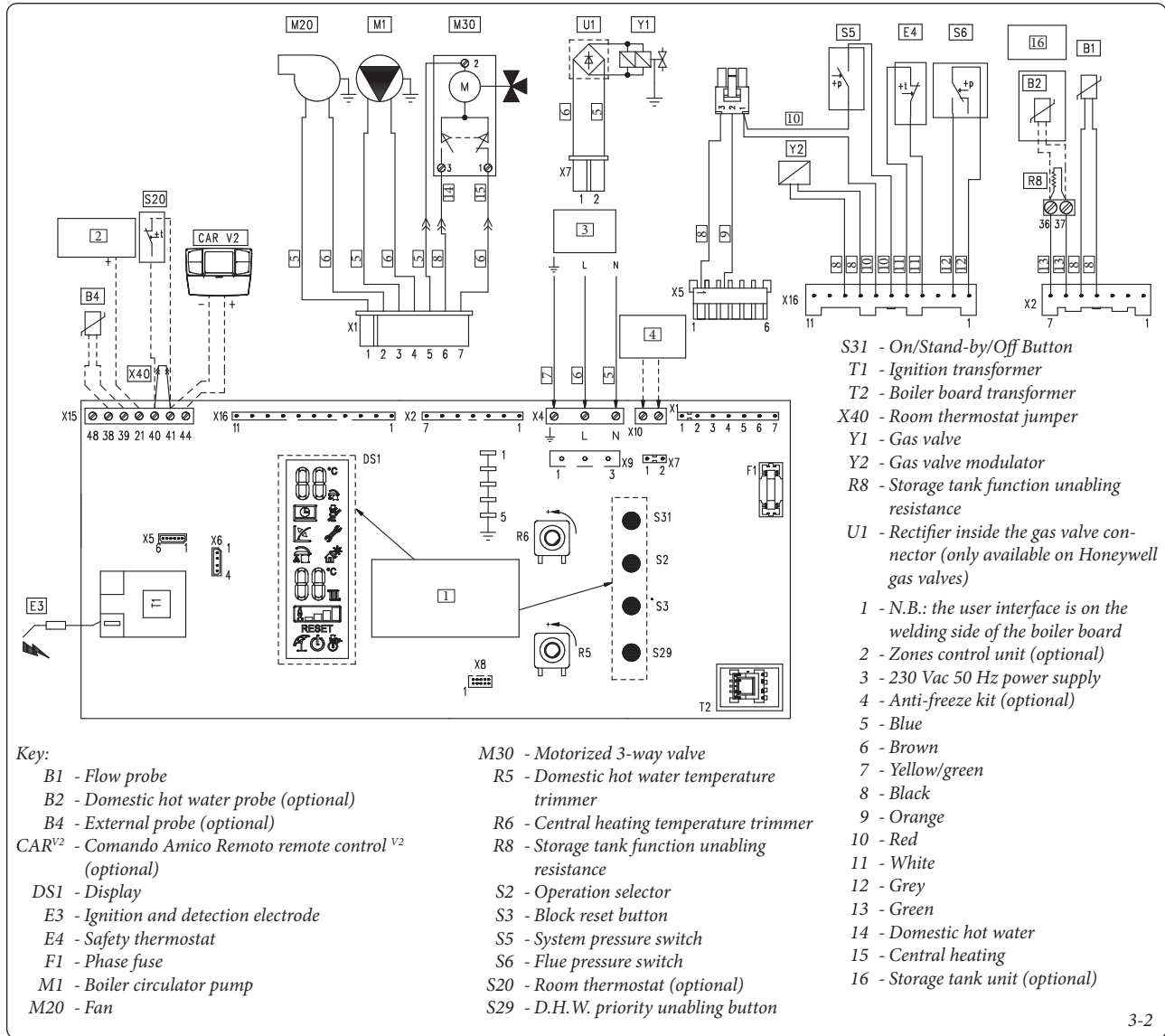

3-2

Remote control: the boiler is set-up for the application of the Comando Amico Remoto remote control<sup>V2</sup> (CAR<sup>V2</sup>) which must be connected to clamps 41 and 44 of connector X15 on the P.C.B., observing polarity and eliminating jumper X40.

Room thermostat: the boiler is designed for the application of the Room Thermostat (S20). Connect it to clamps 40 – 41 eliminating jumper X40.

Storage tank unit: the boiler is set-up for the application of a storage tank unit, which must be connected to clamps 36-37 of the bipolar terminal board located under the sealed chamber and eliminating resistance R8.

The connector X5 is used for the connection to the relay board.

The connector X6 is for connection to a personal computer.

The connector X8 is used for software updating operations.

The DHW probe must be connected to terminals 36 and 37 eliminating the resistance R8.

### 3.3 TROUBLESHOOTING.

**N.B.:** maintenance operations must be carried out by an authorised company (e.g. Authorised After-Sales Technical Assistance Service).

- Smell of gas. Caused by leakage from gas circuit pipelines. Check sealing efficiency of gas intake circuit.
- The fan works but ignition discharge does not take place on the burner ramp. The fan may start but the safety air pressure switch does not switch the contact over. Make sure:
  - 1) that the intake-exhaust duct is not too long (over allowed length).
  - 2) that the intake-exhaust duct is not partially blocked (on the exhaust or intake side).
  - 3) the diaphragm of the flue exhaust is adequate for the length of the intake-exhaust duct.
  - 4) that the sealed chamber is sealed perfectly.
  - 5) the fan power supply voltage is not less than 196 V.
- Irregular combustion (red or yellow flame). Can be caused by: dirty burner, clogged lamellar pack, intake - exhaust terminal not installed properly. Clean the above components and ensure correct installation of the terminal.

- Frequent interventions of the over heating safety thermostat. It can depend on reduced water pressure in the boiler, little circulation in the heating system, the blocked pump or an anomaly of the boiler P.C.B. Check on the pressure gauge that the system pressure is within established limits. Check that radiator valves are not all closed.
- The boiler produces condensate. It can be determined by functioning at boiler temperatures that are excessively low. In this case, make the boiler run at higher temperatures.
- Presence of air in the system. Check opening of the special air vent valve cap (Fig. 1-30). Make sure the system pressure and expansion vessel factory-set pressure values are within the set limits; the factory-set value for the expansion vessel must be 1.0 bar, and system pressure between 1 and 1.2 bar.
- Ignition block see par. 2.5 and 1.6 (electric connection).

### 3.4 INFORMATION MENU.

Pressing the "Summer/Winter" button (4) for 4 seconds, the "Information menu" is activated, which allows to display some boiler functioning parameters.

Press the "Reset" button (5) to scroll the various parameters.

To exit the menu, press the "Summer/Winter" button (4) again for 4 seconds or wait for 120 seconds.

With the menu active on the indicator (17) the parameter n° is displayed while indicator (21) displays the parameter value.

Id Parameter (ref. 17)	Description
d1	Displays the flame signal (uA)
d2	Displays the primary exchanger output instant heating flow temperature
d3	Displays the storage tank unit temperature.
d4	Displays the temperature set for the central heating set (if remote control is present)
d5	Displays the temperature set for the DHW set (if remote control is present)
d6	Displays the external environment temperature (if the external probe is present) If the temperature is below zero, the value is displayed flashing.
d7	Not available

### 3.5 PROGRAMMING THE P.C.B.

The boiler is prepared for possible programming of several operation parameters. By modifying these parameters as described below, the boiler can be adapted according to specific needs.

To access the programming phase, press the "Summer/Winter" (4) and "Reset" (5) buttons simultaneously for 8 seconds.

once the menu has been accessed, it is possible to scroll through the three sub-menus present (s, p, t) by pressing the "Summer/Winter" (4) button for 2 seconds.

Use the "DHW regulator" selector (2), to select the parameter and rotate the "CH regulator" (1) to modify the value according to the range available.

With the menu active on the indicator (17) the parameter n° is displayed while indicator (21) displays the parameter value.

Press the "Reset" button (5) for 2 seconds to memorise the variation of the parameters  
Memorisation is displayed by the flashing indicators (17 and 21).

Exit the programming phase by waiting for 2 minutes or by pressing the "Summer/Winter" (4) and "Reset" (5) buttons simultaneously for 5 seconds.

Id Parameter (ref. 17)	Parameter	Description	Range (ref. 21 Fig. 2-1)	Default
S0	Minimum CH output	The boiler also has electronic modulation that adapts the boiler potentiality to the effective heating demand of the house. Then the boiler works normally in a variable gas pressure field between the minimum heating output and the maximum heating output depending on the system's heating load. <b>N.B.:</b> the boiler is produced and calibrated in the central heating phase at nominal output. Approximately 10 minutes are needed to reach the nominal heat output changeable using parameter (S1).	0 - 60 %	Set according to factory inspection
S1	Maximum CH output	<b>N.B.:</b> the selection of the "Minimum heating output" and "Maximum heating output" parameters, in presence of a heating request, allows boiler ignition and power supply of the modulator with current equal to the value of the respective set value.	0 - 99 %	99
S2	Gas type selection	The setting of this function is used to adjust the boiler so that it can operate with the correct type of gas	nG - Methane lG - LPG Ci - China	The same as the type of gas being used
S3	Boiler type	Establishes the boiler type and its functioning mode 0 = combi 1 = 24 kW storage tank 2 = 28 kW storage tank 3 = 32kW storage tank	0 - 3	2
S4	Power block	Establishes the power at which the boiler must switch on	0 - 50 %	Set according to factory inspection

Id Parameter (ref. 17)	Parameter	Description	Range (ref. 21 Fig. 2-1)	Default
P0	DHW thermostat	Establishes the switch-off modality in DHW mode ( <i>when the boiler is connected to an external storage tank unit</i> ). With the setting of the domestic hot water thermostat on "Hysteresis 1" (value set 0), the boiler ignites to heat the domestic hot water when the water contained in the storage tank unit falls by 3°C with respect to the set temperature, while on "Hysteresis 2" (value set 1), ignition takes place when the water contained in the storage tank unit falls by 10°C with respect to the set temperature.	0 - 1	0
P1	Solar delay timing	This function does not affect the correct functioning of this boiler model.	0 - 30 seconds	0
P2	Pump functioning	The pump can function in two ways. 0 intermittent: in winter "mode" the circulator is managed by the room thermostat or by the remote control 1 continuous: in "winter" mode the circulator is always powered and is therefore always in operation	0 - 1	0
P3	Relay 1 (optional)	The boiler is set-up for functioning with the relay P.C.B. (optional), which can be configured 0 = Off 1 = Main zone control 2 = General alarm 3 = CH phase active 4 = External gas valve power supply 5 = Aquaceleris PTC control (Do not use on this boiler model)	0 - 5	0
P4	Relay 2 (optional)	The boiler is set-up for functioning with the relay P.C.B. (optional), which can be configured 0 = Off 1 = General alarm 2 = CH phase active 3 = External gas valve power supply 4 = Secondary zone control (from TA on relay P.C.B. contact)	0 - 4	0
P5	Relay 3 (optional)	The boiler is set-up for functioning with the relay P.C.B. (optional), which can be configured 0 = Off 1 = Chiller remote activation 2 = General alarm 3 = CH phase active 4 = External gas valve power supply 5 = Aquaceleris PTC control (Do not use on this boiler model)	0 - 5	0

Id Parameter (ref. 17)	Parameter	Description	Range (ref. 21 Fig. 2-1)	Default
t0	Central heating ignitions timer	The boiler has electronic timing, which prevents the burner from igniting too often in central heating mode	0 - 600 seconds	18
t1	Central heating ramp timer	In the ignition phase, the boiler performs an ignition ramp in order to arrive at the maximum power set	6 - 840 seconds	84
t2	CH ignition delay from TA and CR request	The boiler is set to switch-on immediately after a request. In the case of particular systems (e.g. area systems with motorised thermostatic valves etc.) it may be necessary to delay ignition.	0 - 600 seconds	0
t3	Display lighting	Establishes the display lighting mode. 0 <b>Automatic:</b> the display lights up during use and dims after 15 seconds of inactivity. In the event of an anomaly the display flashes. 1 <b>Off:</b> the display is always lit with low intensity 2 <b>On:</b> the display is always lit with high intensity.	0 - 2	0
t4	Display	Establishes what indicators 17 and 21 display (Fig. 2-1). 0 Indicator 17 displays the set DHW set; Indicator 21 in winter mode shows the set CH setting, while the indicator is switched off in summer mode 1 Indicator 17 is off in the presence of a request. Without any request the indicator shows the set DHW set. In the presence of a request, indicator 21 shows the instant flow temperature of the boiler. Without any request in summer mode, the indicator is off. In winter mode it shows the set CH setting.	0 - 1	1



### SIT 845 GAS Valve

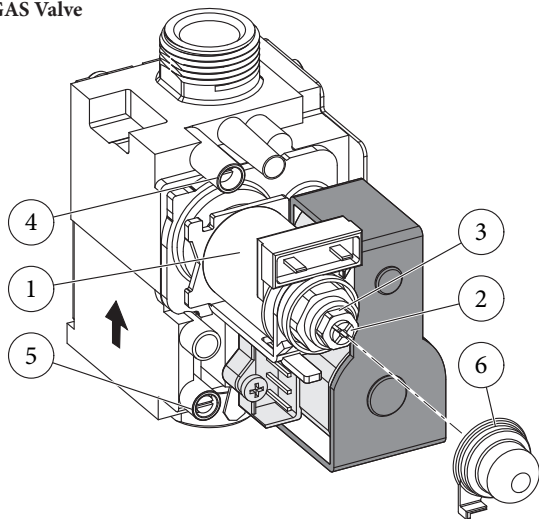

Key:

- 1 - Coil
- 2 - Minimum power adjustment screw
- 3 - Maximum power adjustment nut
- 4 - Gas valve outlet pressure point
- 5 - Gas valve inlet pressure point
- 6 - Protection hood

3-3

INSTALLER

USER

MAINTENANCE TECHNICIAN

### 3.6 CONVERTING THE BOILER TO OTHER TYPES OF GAS.

If the boiler has to be converted to a different gas type to that specified on the data nameplate, request the relative conversion kit for quick and easy conversion.

The gas conversion operation must be carried out by an authorised company (e.g. Authorised Technical After-Sales Service).

To convert to another type of gas the following operations are required:

- disconnect the appliance;
- replace the main burner injectors, making sure to insert the special seal rings supplied in the kit, between the gas manifold and the injectors;
- re-power the appliance;
- from the push button panel on the boiler, select the type of gas (S2) and then select (Ng) if it runs on Methane or (Lg) if it runs on LPG;
- adjust the boiler nominal heat output;
- adjust the minimum heat power of the boiler;
- adjust the boiler nominal heat output in heating phase;
- adjust (eventually) the maximum heating power;
- seal the gas flow rate regulation devices (if settings are modified);
- after completing the conversion, apply the sticker, contained in the conversion kit, near the data nameplate. Using an indelible marker pen, delete the data relative to the old type of gas.

These adjustments must be made with reference to the type of gas used, following that given in the table (Par. 3.18).

### 3.7 CHECKS FOLLOWING CONVERSION TO ANOTHER TYPE OF GAS.

After making sure that conversion was carried out with a nozzle of suitable diameter for the type of gas used and the settings are made at the correct pressure, check that:

- there is no flame in the combustion chamber
- the burner flame is not too high or low and that it is stable (does not detach from burner)
- the pressure testers used for calibration are perfectly closed and there are no leaks from the gas circuit.

N.B.: all boiler adjustment operations must be

carried out by a qualified company (e.g. Authorised After-Sales Assistance). Burner adjustment must be carried out using a differential "U" or digital type pressure gauge connected to the pressure socket located above the sealed chamber (part. 9 Fig. 1-30) and the gas valve pressure outlet (part. 4 Fig. 3-3), keeping to the pressure value given in the table (Par. 3.18) according to the type of gas for which the boiler is prepared.

### 3.8 POSSIBLE ADJUSTMENTS.

N.B.: to adjust the gas valve, remove the plastic cap (6); after adjusting, refit the cap.

- Preliminary calibration operations.
  - Set parameter S0 at 0 %.
  - Set parameter S1 at 99 %.
- Activate the chimney sweep function.
  - Enter the "DHW chimney sweep" mode, opening a DHW cock.

**Attention:** if the boiler is set-up solely for central heating, calibrate with chimney sweep in "central heating" mode.
- Adjustment of boiler nominal thermal heat output.
  - Set the power at maximum (99%) by turning the "CH regulator" selector (1).
  - With the brass nut (3 Fig. 3-3) adjust the boiler nominal output, observing the maximum pressure values stated in the tables (Par. 3.18) according to the type of gas; by turning clockwise the heat potential increases, anti-clockwise it decreases.
- Adjustment of boiler minimum thermal heat output.

N.B.: only proceed after having calibrated the nominal pressure.

- Set the power at minimum (0%) still using the "CH regulator" selector (1).
  - Adjust the minimum thermal input by operating on the cross plastic screws (2) on the gas valve maintaining the brass nut blocked (3);
- Exit the "Chimney sweep" mode and keep the boiler functioning.
  - Adjustment of the boiler minimum heat output in heating phase.

N.B.: only proceed after having calibrated the

minimum boiler pressure.

- To adjust the minimum heat output during the heating phase, change parameter (S0), increasing the value the pressure increases, reducing it the pressure drops.
- The pressure to which the boiler minimum heat output must be adjusted, must not be lower than that stated in the tables (par. 3.18).

- Adjustment (any) of the boiler maximum heat output in central heating phase.

To adjust the maximum heat output during the heating phase, change parameter (S1), increasing the value the pressure increases, reducing it the pressure drops.

- The pressure at which the maximum boiler heat output must be set in the central heating stage.

### 3.9 SLOW AUTOMATIC IGNITION FUNCTION.

In ignition phase, the P.C.B. supplies constant gas with pressure proportional to the parameter "S4" set.



**3.10 "CHIMNEY SWEEP" FUNCTION.**

When activated, this function forces the boiler to variable output for 15 minutes. In this state all adjustments are excluded and only the safety thermostat and the limit thermostat remain active. To activate the chimney sweep function, press the "Reset" button (5) event for activation in the absence of DHW requests.

Its activation is signalled by the indication of the flow temperature on the indicator (17), the power percentage on the indicator (21) and activation of the relative symbol .

This function allows the technician to check the combustion parameters.

Once the function is activated, it is possible to select whether to perform the check in CH status or in DHW status by opening any domestic hot water tap (*when the boiler is connected to an external storage tank unit*) and regulating the power by turning the "CH regulation" selector (1).

Functioning in CH or DHW mode is visualised by the relative flashing symbols  or .

On completion of the checks, deactivate the function by pressing the Reset button (5) for 8 seconds.

**3.11 PUMP ANTI-BLOCK FUNCTION.**

The boiler has a function that starts the pump once every 24 hours for the duration of 30 seconds in order to reduce the risk of the pump becoming blocked due to prolonged inactivity.

**3.12 THREE-WAY ANTI-BLOCK FUNCTION.**

The boiler is supplied with a function that activates the motorised three-way unit every 24 hours, carrying out a complete cycle in order to reduce the risk of three-way block due to prolonged inactivity.

**3.13 RADIATOR ANTIFREEZE FUNCTION.**

If the system return water is below 4°C, the boiler starts up until reaching 42°C.

**3.14 P.C.B. PERIODICAL SELF-CHECK.**

During functioning in central heating mode or with boiler in standby, the function activates every 18 hours after the last boiler check/power supply. In case of functioning in domestic hot water mode the self-check starts within 10 minutes after the end of the withdrawing in progress, for duration of approx. 10 seconds.

**N.B.:** during self-check, the boiler remains off, including signalling.

**3.15 SOLAR PANELS COUPLING FUNCTION.**

In the event of integration of DHW heating with solar panel systems, for correct use of the boiler in this condition, it is necessary to set parameter P0 (DHW thermostat) on "1" (Hysteresis 2).

**3.16 APPLIANCE CHECK AND MAINTENANCE.**

The following checks and maintenance should be performed at least once a year.

- Clean the flue side of the heat exchanger.
- Clean the main burner.
- Visually check the flue hood for deterioration or corrosion.
- Check ignition and operation.
- Check the correct calibration of the burner in the DHW phase (*when the boiler is connected to an external cylinder unit*) and central heating phase.
- Check the operation of the appliance control and adjustment devices and in particular:
  - intervention of main electrical switch positioned outside of the boiler;
  - system control thermostat intervention;
  - the intervention of the DHW adjustment thermostat (*when the boiler is connected to an external storage tank unit*).
- Check sealing efficiency of the gas circuit and the internal system.
- Check the intervention of the device against no gas ionisation flame control. Intervention time must be less than 10 seconds.
- Visually check for water leaks or oxidation from/on connections.
- Visually check that the water safety drain valve is not clogged.
- Check, after discharging the system pressure and bringing it to zero (read on boiler pressure gauge), that the expansion vessel charge is at 1.0 bar.
- Check that the system static pressure (with system cold and after refilling the system by means of the filling cock) is between 1 and 1.2 bar.
- Visually check that the safety and control devices have not been tampered with and/or shorted, in particular:
  - temperature safety thermostat;
  - water pressure switch,
  - air pressure switch
- Check the condition and integrity of the electrical system and in particular:
  - supply voltage cables must be inside the fairleads;
  - there must be no traces of blackening or burning.

**N.B.:** in addition to yearly maintenance, one must also check the thermal system, with frequency and procedures that comply with the indications of the technical regulations in force.

### 3.17 CASING REMOVAL.

To facilitate boiler maintenance the casing can be completely removed as follows (Fig. 3-4 / 3-5):

- 1 Undo the 2 bottom screws (b) that fasten the protection guard (a).
- 2 Release the guard (a).
- 3 Unhook the decorative frame (c) from the relative lower retainers.
- 4 Remove the decorative frame (c) from the casing (e).
- 5 Loosen the 2 front screws (d) that fasten the casing.
- 6 Loosen the 2 lower screws (f) that fasten the casing.
- 7 Pull the case towards you (e).
- 8 At the same time, push the case (e) upwards to release it from the upper hooks.

#### Installation drawings key:

- a** Unmistakeable component identification
- 1** Sequential identification of the operation to perform

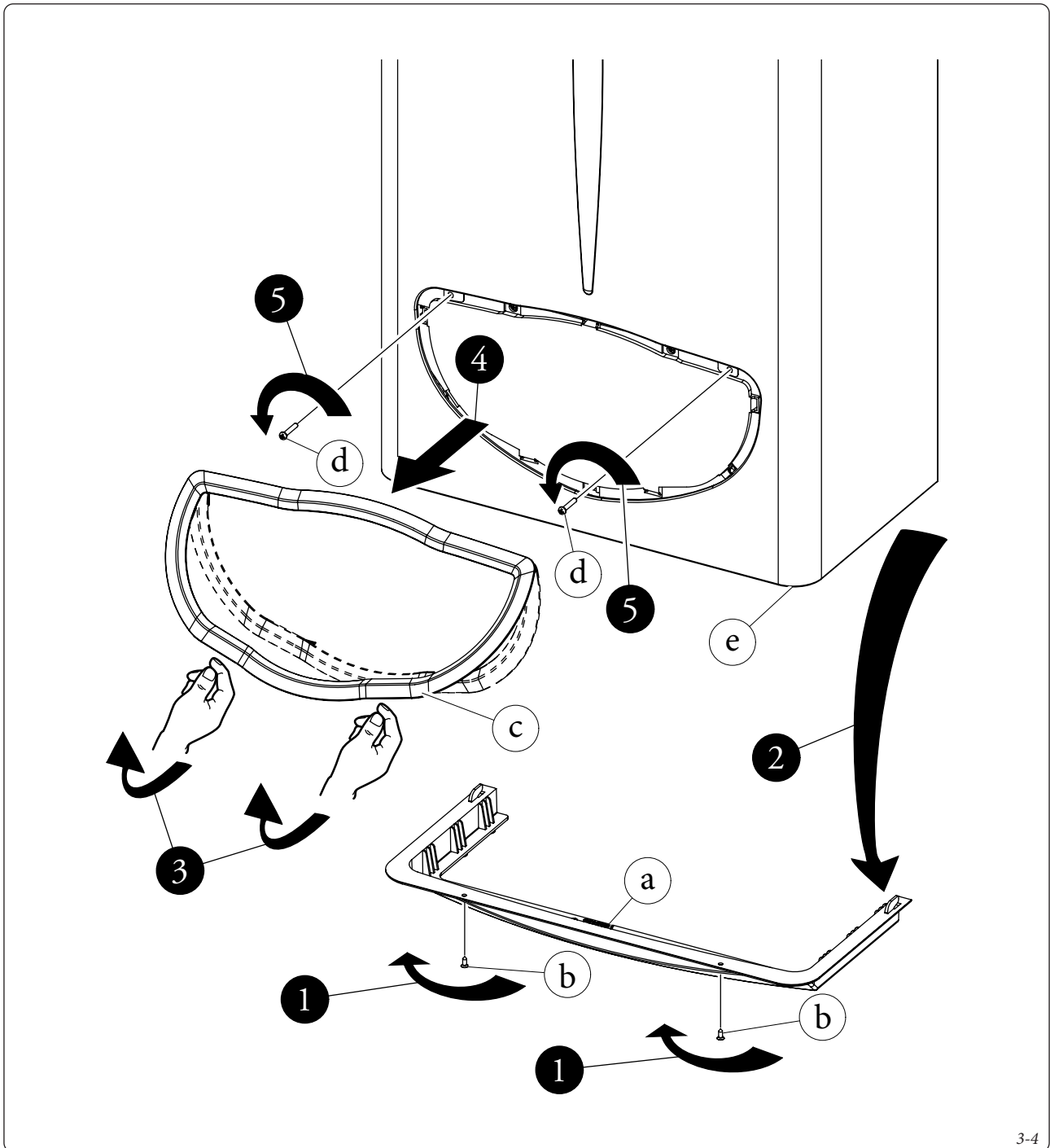

INSTALLER

USER

MAINTENANCE TECHNICIAN

INSTALLER

USER

MAINTENANCE TECHNICIAN

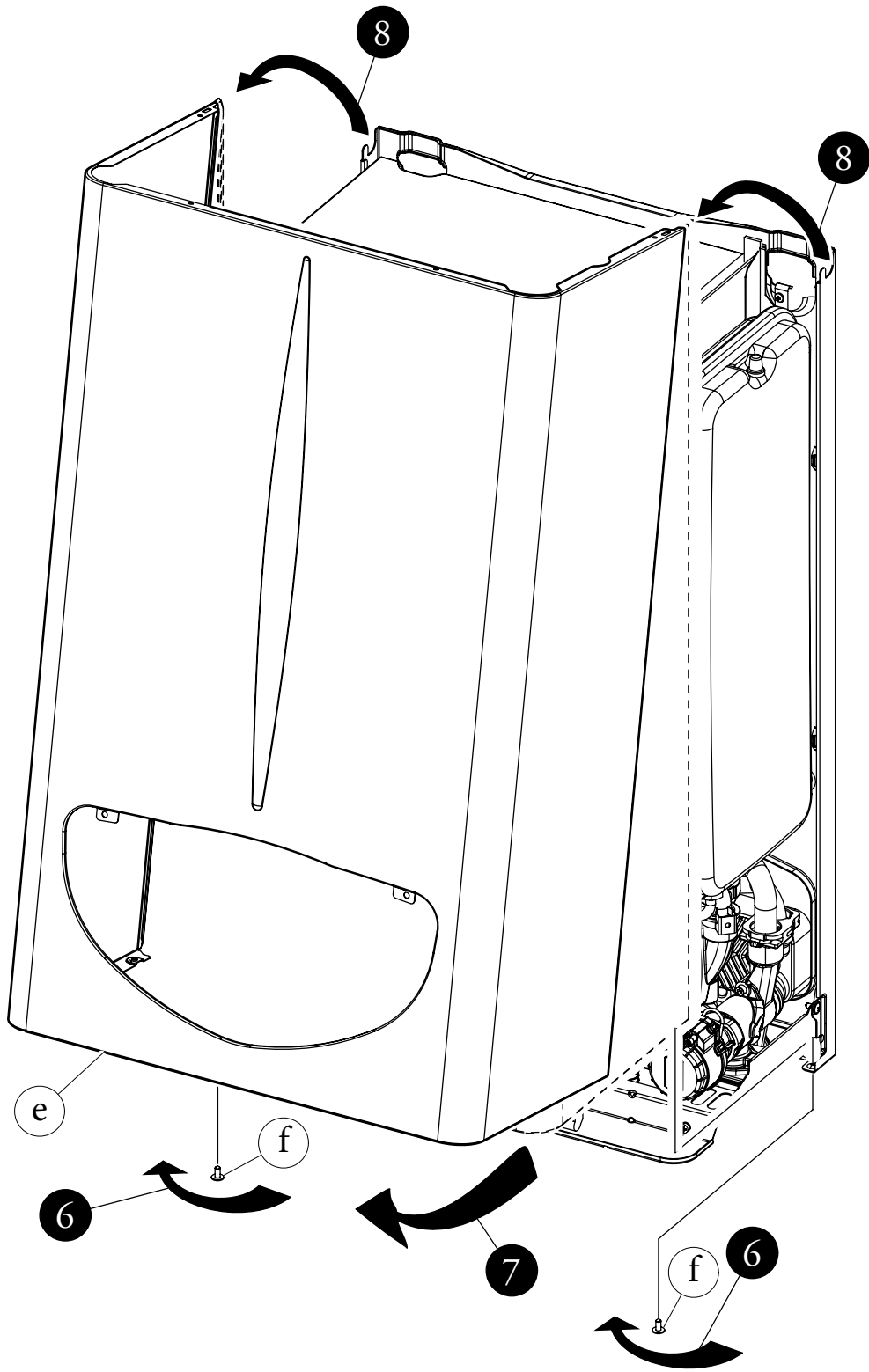

STD.010252/000

**3.18 VARIABLE HEAT OUTPUT.**

**N.B.:** the pressures indicated in the table represent the difference in existing pressures between the gas valve outlet and the combustion chamber. The adjustments should therefore, be carried out using a differential manometer (small "U"-shaped

column or digital manometer) with the probes inserted in the pressure test gas valve outlet and on the sealed chamber positive pressure test. The power data in the table has been obtained with intake-exhaust pipe measuring 0.5 m in length. Gas flow rates refer to heating power below a tem-

perature of 15°C and at a pressure of 1013 mbar. Burner pressure values refer to use of gas at 15°C.

		METHANE (G20)			BUTANE (G30)			PROPANE (G31)		
THERMAL POWER	THERMAL POWER	BURNER GAS FLOW RATE	PRESS. BURNER NOZZLES	BURNER GAS FLOW RATE	PRESS. BURNER-NOZZLES	BURNER GAS FLOW RATE	PRESS. BURNER-NOZZLES	BURNER GAS FLOW RATE	PRESS. BURNER NOZZLES	
(kW)	(kcal/h)	(m³/h)	(mbar) (mm H <sub>2</sub> O)	(kg/h)	(mbar) (mm H <sub>2</sub> O)	(kg/h)	(mbar) (mm H <sub>2</sub> O)	(kg/h)	(mbar) (mm H <sub>2</sub> O)	
28.0	24080	3.14	11.70 119.3	2.35	28.05 286.1	2.31	35.87 365.8			
27.0	23220	3.03	10.91 111.2	2.26	26.32 268.4	2.22	33.41 340.7			
26.2	22516	2.94	10.28 104.8	2.19	24.95 254.5	2.16	31.48 321.0			
25.0	21500	2.81	9.42 96.1	2.10	23.06 235.2	2.06	28.83 294.0			
24.0	20640	2.70	8.73 89.0	2.02	21.52 219.5	1.98	26.71 272.3			
23.0	19780	2.59	8.06 82.2	1.94	20.04 204.4	1.90	24.68 251.7			
22.0	18920	2.49	7.43 75.8	1.86	18.61 189.8	1.83	22.76 232.1			
21.0	18060	2.38	6.82 69.6	1.78	17.24 175.8	1.75	20.92 213.4			
20.0	17200	2.27	6.24 63.7	1.70	15.91 162.3	1.67	19.18 195.6			
19.0	16340	2.17	5.69 58.0	1.62	14.63 149.2	1.59	17.52 178.6			
18.0	15480	2.06	5.16 52.6	1.54	13.39 136.6	1.52	15.94 162.5			
17.0	14620	1.96	4.65 47.4	1.46	12.20 124.4	1.44	14.44 147.3			
16.0	13760	1.85	4.16 42.4	1.38	11.04 112.6	1.36	13.02 132.8			
15.0	12900	1.75	3.70 37.7	1.30	9.93 101.2	1.28	11.67 119.0			
14.0	12040	1.64	3.26 33.2	1.23	8.85 90.2	1.21	10.40 106.1			
13.0	11180	1.54	2.84 28.9	1.15	7.81 79.6	1.13	9.21 93.9			
12.0	10320	1.43	2.44 24.8	1.07	6.80 69.3	1.05	8.08 82.4			
11.2	9632	1.34	2.13 21.7	1.00	6.02 61.4	0.98	7.24 73.8			
10.0	8600	1.21	1.70 17.3	0.90	4.89 49.9	0.89	6.06 61.8			
9.0	7740	1.10	1.36 13.9	0.82	3.99 40.6	0.81	5.16 52.6			
8.5	7310	1.04	1.20 12.2	0.78	3.55 36.2	0.77	4.74 48.3			

CH + D.H.W.  
D.H.W.

**3.19 COMBUSTION PARAMETERS.**

		G20	G30	G31
Gas nozzle diameter	mm	1.35	0.78	0.78
supply pressure	mbar (mm H <sub>2</sub> O)	20 (204)	29 (296)	37 (377)
Flue flow rate at nominal heat output	kg/h	58	57	59
Flue flow rate at min heat output	kg/h	60	61	64
CO <sub>2</sub> at Q. Nom./Min.	%	7.35 / 2.85	8.65 / 3.30	8.40 / 3.10
CO with 0% O <sub>2</sub> at Nom./Min. Q. Nom./Min.	ppm	73 / 126	93 / 164	65 / 155
NO <sub>x</sub> at 0% of O <sub>2</sub> at Q. Nom./Min.	mg/kWh	152 / 123	234 / 150	202 / 111
Flue temperature at nominal output	°C	110	114	112
Flue temperature at minimum output	°C	77	78	79

Combustion parameters: measuring conditions of useful efficiency (flow temperature/return temperature= 80/60 °C), ambient temperature reference = 15°C.

INSTALLER

USER

MAINTENANCE TECHNICIAN

## 3.20 TECHNICAL DATA.

Nominal heat input	kW (kcal/h)	29.7 (25536)
(**) DHW minimum heat input	kW (kcal/h)	9.9 (8480)
CH minimum heat input	kW (kcal/h)	12.7 (10902)
Nominal heat output (useful)	kW (kcal/h)	28.0 (24080)
(**) DHW minimum heat output (effective)	kW (kcal/h)	8.5 (7310)
CH minimum heat output (useful)	kW (kcal/h)	11.2 (9632)
Efficiency at nominal heat output	%	94.3
Efficiency at 30% nominal heat output load	%	91.5
Heat loss at case with burner On/Off	%	0.0 / 0.53
Heat loss at flue with burner On/Off	%	5.7 / 0.06
Central heating circuit max. operating pressure	bar	3.0
Maximum heating temperature	°C	90
Adjustable central heating temperature	°C	35 - 85
System expansion vessel total volume	l	7.4
Heating expansion vessel pre-charge	bar	1.0
Appliance water content	l	1.3
Head available with 1000 l/h flow rate	kPa (m H <sub>2</sub> O)	32.46 (3.30)
(**) Hot water production useful heat output	kW (kcal/h)	28.0 (24080)
(**) Domestic hot water adjustable temperature	°C	10 - 60
(**) Domestic hot water circuit min. pressure (dynamic)	bar	0.3
(**) Domestic hot water circuit max. operating pressure	bar	10.0
Weight of full boiler	kg	38.6
Weight of empty boiler	kg	37.3
Electrical connection	V/Hz	230/50
Nominal absorption	A	0.74
Installed electric power	W	130
Pump consumption	W	84.0
Fan power absorbed power	W	46.0
Equipment electrical system protection	-	IPX5D
NO <sub>x</sub> class	-	3
Weighted NO <sub>x</sub>	mg/kWh	107
Weighted CO	mg/kWh	92
Type of appliance	C12 / C32 / C42 / C52 / C82 / B22p / B32	
Category	II2H3+	

- Flue gas temperature values refer to an air inlet temperature of 15°C.
- The data relevant to domestic hot water performance refer to a dynamic inlet pressure of 2 bar and an inlet temperature of 15°C; the values are measured directly at the boiler outlet considering that to obtain the data declared mixing with cold water is necessary.

- The max. sound level emitted during boiler operation is < 55dBA. The sound level value is referred to semianechoic chamber tests with boiler operating at max. heat output, with extension of flue gas exhaust system according to product standards.
- (\*\*) When the boiler is connected to an external storage tank unit.



### 3.21 KEY FOR DATA NAMEPLATE.

Md		Cod. Md	
Sr N°	CHK	Cod. PIN	
Type			
Q <sub>nw</sub> /Q <sub>n</sub> min.	Q <sub>nw</sub> /Q <sub>n</sub> max.	P <sub>n</sub> min.	P <sub>n</sub> max.
PMS	PMW	D	TM
NO <sub>x</sub> Class			

**N.B.:** the technical data is provided on the data nameplate on the boiler

	ENG
Md	Model
Cod. Md	Model code
Sr N°	Serial Number
CHK	Check
Cod. PIN	PIN code
Type	Type of installation (ref. CEN TR 1749)
Q <sub>nw</sub> min.	Minimum DHW heat input
Q <sub>n</sub> min.	CH minimum heat input
Q <sub>nw</sub> max.	DHW maximum heat input
Q <sub>n</sub> max.	CH maximum heat input
P <sub>n</sub> min.	Minimum heat output
P <sub>n</sub> max.	Maximum heat output
PMS	Maximum system pressure
PMW	Maximum domestic hot water pressure
D	Specific flow rate
TM	Maximum operating temperature
NO <sub>x</sub> Class	NO <sub>x</sub> Class







This instruction booklet  
is made of ecological paper



[immergas.com](http://immergas.com)

Immergas Europe S.r.o.  
059051 Poprad - Matejovce - SK  
Tel. +421.524314311  
Fax +421.524314316



**IMMERCAS**  
IMMERCAS SPA - ITALY  
CERTIFIED COMPANY  
UNI EN ISO 9001:2015

Design, manufacture and post-sale assistance of gas  
boilers, gas water heaters and related accessories

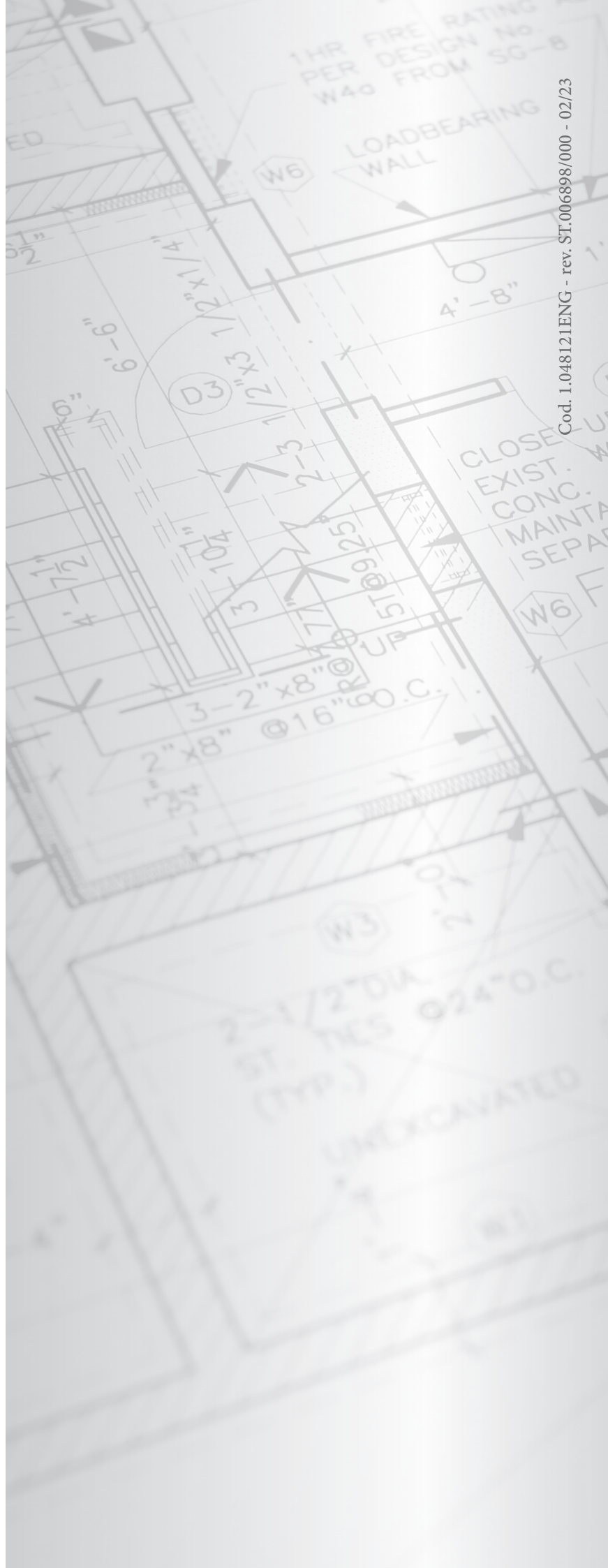

Cod. I.048121ENG - rev. ST.006898/000 - 02/23

STD.010252/000