

MANUAL
OWNER'S

Instruction booklet and **IE**
warning

 **IMMERGAS**

**MINI NIKE
X 243 E**

1.048119ENG



Dear Customer,

Our compliments for having chosen a top-quality Immergas product, able to assure well-being and safety for a long period of time. As an Immergas customer you can also count on a qualified after-sales service, prepared and updated to guarantee constant efficiency of your boiler. Read the following pages carefully: you will be able to draw useful suggestions regarding the correct use of the appliance, the respect of which, will confirm your satisfaction for the Immergas product.

For any interventions or routine maintenance contact Authorised Centres: these have original spare parts and boast of specific preparation directly from the manufacturer.

General recommendations

All Immergas products are protected with suitable transport packaging.

The material must be stored in dry environments protected against bad weather.

The instruction book is an integral and essential part of the product and must be consigned to the new user also in the case of transfer or succession of ownership.

It must be stored with care and consulted carefully, as all of the warnings provide important safety indications for installation, use and maintenance stages.

This instruction manual provides technical information for installing the Immergas kit. As for the other issues related to boiler installation (e.g. safety in the work site, environment protection, injury prevention), it is necessary to comply with the provisions specified in the current regulation and technical standards.

In compliance with legislation in force, the systems must be designed by qualified professionals, within the dimensional limits established by the Law. Installation and maintenance must be performed in compliance with the regulations in force, according to the manufacturer's instructions and by an authorised company, which has specific technical expertise in the system sector, as required by Law.

Improper installation or assembly of the Immergas appliance and/or components, accessories, kit and devices can cause unexpected problem to persons, animals and objects. Read the instructions provided with the product carefully to ensure a proper installation.

Maintenance must be carried out by an authorised company. The Authorised After-sales Service represents a guarantee of qualification and professionalism.

The appliance must only be destined for the use for which it has been expressly declared. Any other use will be considered improper and therefore potentially dangerous.

If errors occur during installation, operation and maintenance, due to non compliance with technical laws in force, standards or instructions contained in this book (or however supplied by the manufacturer), the manufacturer is excluded from any contractual and extra-contractual liability for any damages and the appliance warranty is invalidated.

Product not intended for EU countries.

The manufacturer declines all liability due to printing or transcription errors, reserving the right to make any modifications to its technical and commercial documents without forewarning.

INDEX

INSTALLATOR	page
1 Boiler installation	5
1.1 Installation recommendations.....	5
1.2 Main dimensions.....	5
1.3 Gas connection.....	6
1.4 Hydraulic connection.....	6
1.5 Electrical connection.	6
1.6 Remote controls and room chronothermostats (optional).	6
1.7 External probe (optional).....	7
1.8 Ventilation of the rooms.	7
1.9 Flue ducts.	7
1.10 Flues/chimneys.....	7
1.11 System filling.....	8
1.12 Gas system start-up.....	8
1.13 Boiler start up (ignition).	8
1.14 Circulation pump.	8
1.15 Kits available on request.....	8
1.16 Boiler components.....	9

USER	page
2 Instructions for use and maintenance..	10
2.1 Cleaning and maintenance.	10
2.2 Ventilation of the rooms.....	10
2.3 General warnings.....	10
2.4 Control panel.....	10
2.5 Using the boiler.....	11
2.6 Troubleshooting.	11
2.7 Boiler shutdown.	13
2.8 Restore central heating system pressure.....	13
2.9 System draining.....	13
2.10 Anti-freeze protection.....	13
2.11 Case cleaning.....	13
2.12 Decommissioning	13

MAINTENANCE TECHNICIAN	page
3 Boiler start-up (initial check).	14
3.1 Hydraulic diagram.....	14
3.2 Wiring diagram.....	15
3.3 Troubleshooting.....	15
3.4 Information menu.....	16
3.5 Programming the p.C.B.	16
3.6 Converting the boiler to other types of gas.....	17
3.7 Checks following conversion to another type of gas.....	17
3.8 Possible adjustments.....	18
3.9 Automatic slow ignition function with timed ramp delivery.....	18
3.10 Chimney sweep” function.....	18
3.11 Pump anti-block function.....	18
3.12 Three-way anti-block function.....	18
3.13 Radiators anti-freeze function.....	18
3.14 P.C.B. Periodical self-check.....	18
3.15 Solar panels coupling function.....	18
3.16 Casing removal.....	19
3.17 Yearly appliance check and maintenance.....	21
3.18 Variable heat output.....	22
3.19 Combustion parameters.....	22
3.20 Technical data.....	23
3.21 Data plate key.....	24

1 BOILER INSTALLATION

1.1 INSTALLATION RECOMMENDATIONS.

The Mini Nike X 24 3 E boiler has been designed for wall mounted installation only, for heating environments and production of domestic hot water (when the boiler is connected to an external storage tank unit) for domestic use and similar purposes.

The place of installation of the appliance and relative Immergas accessories must have suitable features (technical and structural) such to allow (always in safety, efficiency and comfortable conditions):

- installation (according to the provisions of the technical legislation and technical regulations);
- maintenance operations (including scheduled, periodic, routine and special maintenance);
- removal (to outdoors in the place for loading and transporting the appliances and components) as well as their eventual replacement with appliances and/or equivalent components.

The wall surface must be smooth, without any protrusions or recesses enabling access to the rear part. They are not designed to be installed on plinths or floors (Fig. 1-1).

Only professionally enabled companies are authorised to install Immergas gas appliances. Installation must be carried out according to regulation standards, current legislation and in compliance with local technical regulations and the required technical procedures.

Important: the manufacturer declines all liability for damages caused by boilers removed from other systems or for any non-conformities of such equipment.

Before installing the appliance, ensure that it is delivered in perfect condition; if in doubt, contact the supplier immediately. Packing materials (staples, nails, plastic bags, polystyrene foam, etc.) constitute a hazard and must be kept out of the reach of children. If the appliance is installed inside or between cabinets, ensure sufficient space for normal servicing; therefore it is advisable to leave clearance of at least 3 cm between the boiler casing and the vertical sides of the cabinet. Leave adequate space above the boiler for possible water and flue removal connections. It is just as important that the intake grids are not obstructed. Keep all flammable objects away from the appliance (paper, rags, plastic, polystyrene, etc.). Do not place household appliances underneath the boiler as they could

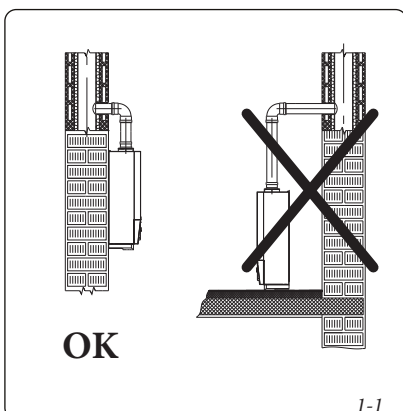

be damaged if the safety valve intervenes with an obstructed conveying system (the safety valve must be conveyed away by a draining funnel), or if there are leaks from the hydraulic connections; on the contrary, the manufacturer cannot be held responsible for any damage caused to the household appliances.

For the aforementioned reasons, we recommend not placing furnishings, furniture, etc. under the boiler.

In the event of malfunctions, faults or incorrect operation, turn the appliance off immediately and contact an authorised company (e.g. the Technical Assistance centre, which has specifically trained staff and original spare parts). Do not attempt to modify or repair the appliance alone. Failure to comply with the above implies personal responsibility and invalidates the warranty.

• Installation regulations:

- installation of these boilers in bedrooms, studio flats and bathrooms, or in premises where there are wood fired heaters (or by solid fuels in general) and in premises next to or connected to them, is subject to the regulatory/legislative provisions in force in the country.
- Installation of gas appliances, flue exhaust pipes and combustion air intake pipes is

forbidden in places with a fire risk (for example: garages, closed parking stalls), and in potentially dangerous places.

- installation is prohibited on the vertical projection of cooking hobs;
- installation is forbidden in places/rooms that constitute public areas of apartment buildings, internal stairways or other escape routes (e.g. floor landings, entrance halls, etc.).
- Installation is also forbidden in places/rooms that constitute public areas of apartment buildings such as cellars, entrance halls, attics, lofts, etc., unless otherwise provided for by local regulations in force.
- type B open chamber boilers must not be installed in places where commercial, artisan or industrial activities take place, which use products that may develop volatile vapours or substances (e.g. acid vapours, glues, paints, solvents, combustibles, etc.), as well as dusts (e.g. dust deriving from the working of wood, coal fines, cement, etc.), which may be harmful for the components of the appliance and jeopardise operation;
- they must also be installed in rooms where the temperature cannot fall below 0°C and must not be exposed to weathering.

1.2 MAIN DIMENSIONS.

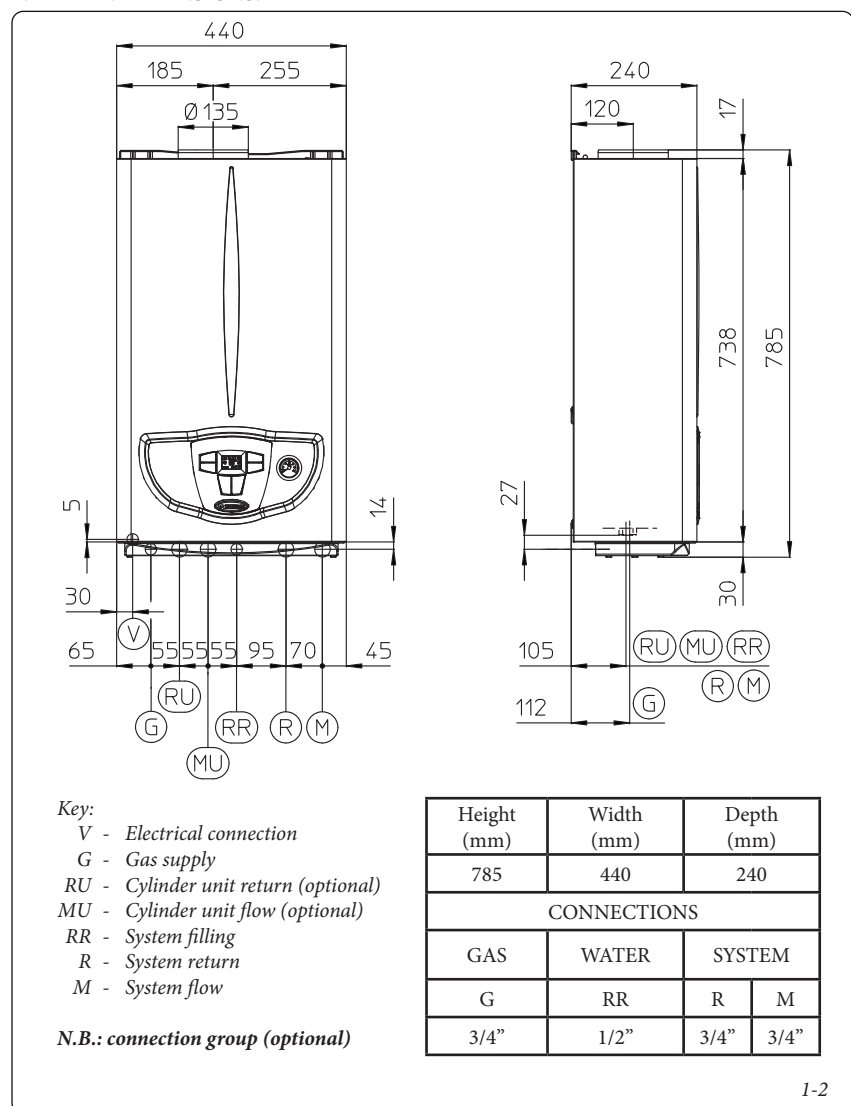

Attention: wall mounting of the boiler must guarantee stable and efficient support for the generator.

The plugs (standard supply) are to be used only in conjunction with the mounting brackets or fixing template to fix the appliance to the wall; they only ensure adequate support if inserted correctly (according to technical standards) in walls made of solid or semi-hollow brick or block. In the case of walls made from hollow brick or block, partitions with limited static properties, or in any case walls other than those indicated, a static test must be carried out to ensure adequate support.

N.B.: the hex head screws supplied in the blister pack are to be used exclusively to fix the relative mounting bracket to the wall.

These boilers are used to heat water to below boiling temperature in atmospheric pressure.

They must be connected to a central heating system and hot water circuit suited to their performance and capacity.

They cannot be connected directly to low-temperature systems.

1.3 GAS CONNECTION.

Our boilers are designed to operate with methane gas (G20) and LPG. Supply pipes must be the same as or larger than the 3/4" G boiler fitting. Before connecting the gas line, carefully clean inside all the fuel feed system pipes to remove any residue that could impair boiler efficiency. Also make sure the gas corresponds to that for which the boiler is prepared (see boiler data-plate). If different, the appliance must be converted for operation with the other type of gas (see converting appliance for other gas types). The dynamic gas supply (methane or LPG) pressure must also be checked according to the type used in the boiler, as insufficient levels can reduce generator output and cause malfunctions.

Ensure correct gas cock connection by following the mounting instructions illustrated in the figure. The gas supply pipe must be suitably dimensioned according to current regulations in order to guarantee correct gas flow to the burner even in conditions of maximum generator output and to guarantee appliance efficiency (technical specifications). The coupling system must conform to standards.

Fuel gas quality. The appliance has been designed to operate with gas free of impurities; otherwise it is advisable to fit special filters upstream from the appliance to restore the purity of the gas.

Storage tanks (in case of supply from LPG depot).

- New LPG storage tanks may contain residual inert gases (nitrogen) that degrade the mixture delivered to the appliance causing functioning anomalies.

- Due to the composition of the LPG mixture, layering of the mixture components may occur during the period of storage in the tanks. This can cause a variation in the heating power of the mixture delivered to the appliance, with subsequent change in its performance.

1.4 HYDRAULIC CONNECTION.

Important: In order not to void the warranty before making the boiler connections, carefully clean the heating system on the primary heat exchanger (pipes, radiators, etc.) with special pickling or de-scaling products to remove any deposits that could compromise correct boiler operation.

A treatment of the heating and water system water is required, in compliance with the technical standards in force, in order to protect the system and the appliance from deposits (e.g. scale), slurry or other hazardous deposits.

Hydraulic connections must be made in a rational way using the couplings on the boiler template. The boiler safety valve outlet must be connected to an appropriate drain. Otherwise, the manufacturer declines any responsibility in case of flooding if the drain valve cuts in.

Attention: the manufacturer declines all liability in the event of damage caused by the installation of an automatic filling system.

In order to meet the system requirements established by the technical regulation in force in relation to the pollution of drinking water, we recommend installing the IMMERGAS anti-backflow kit to be used upstream of the cold water inlet connection of the boiler. It is also recommended that the heat transfer fluid (e.g. water + glycol) entered in the primary circuit of the boiler (heating circuit), complies with the local regulations in force.

Important: to preserve the duration of appliance efficiency features, in the presence of water whose features can lead to the deposit of lime scale, installation of the "polyphosphate dispenser" kit is recommended.

1.5 ELECTRICAL CONNECTION.

The Mini Nike X 24 3 E boiler has an IPX4D protection rating for the entire appliance. Electrical safety of the unit is reached when it is correctly connected to an efficient earthing system as specified by current safety standards.

Important: the manufacturer declines any responsibility for damage or physical injury caused by failure to connect the boiler to an efficient earth system or failure to comply with the reference standards.

Also ensure that the electrical installation corresponds to maximum absorbed power specifications as shown on the boiler data-plate. Boilers are supplied complete with an "X" type power cable without plug. The power supply cable must be connected to a 230V $\pm 10\%$ / 50Hz mains supply respecting L-N polarity and earth connection \oplus . This network must also have an omnipolar circuit breaker with class III over-voltage category. When replacing the power supply cable, contact an authorised company (e.g. Authorised Technical After-Sales Service). The power cable must be laid as shown. In the event of mains fuse replacement on the P.C.B., use a 2A quick-blow fuse. For the main power supply to the appliance, never use adapters, multiple sockets or extension leads.

1.6 REMOTE CONTROLS AND ROOM CHRONOTHERMOSTATS (OPTIONAL).

The boiler is prepared for the application of room chronothermostats or remote controls, which are available as optional kits. (Fig. 1-3)

All Immergas chronothermostats can be connected with 2 wires only. Carefully read the user and assembly instructions contained in the accessory kit.

• On/Off digital chrono-thermostat. The chrono-thermostat allows:

- set two room temperature value: one for day (comfort temperature) and one for night (reduced temperature);

- set a weekly programme with four daily switch on and switch off times;

- selecting the required function mode from the various possible alternatives:

- manual mode (with adjustable temperature).
- automatic mode (with set programme).
- forced automatic mode (momentarily changing the temperature of the automatic programme).

The chrono-thermostat is powered by two 1.5V LR 6 type alkaline batteries.

• "Comando Amico Remoto" remote Control Device^{V2} (CAR^{V2}) with climate chronothermostat function. In addition to the functions described in the previous point, the CAR panel^{V2} enables the user to control all the important information regarding operation of the appliance and the heating system with the opportunity of easily intervening on the previously set parameters without having to go to the place where the appliance is installed. The panel is provided with self-diagnosis to display any boiler functioning anomalies. The climate chronothermostat incorporated into the remote panel enables the system flow temperature to be adjusted to the actual needs of the room being heated, in order to obtain the desired room temperature with extreme precision and therefore with evident saving in running costs. CAR^{V2} is powered directly by the boiler via the same 2 wires that are used for data transmission between the boiler and the device.

Important: If the system is subdivided into zones using the relevant kit, the CAR^{V2} must be used with its climate thermostat function disabled, i.e. it must be set to On/Off mode.

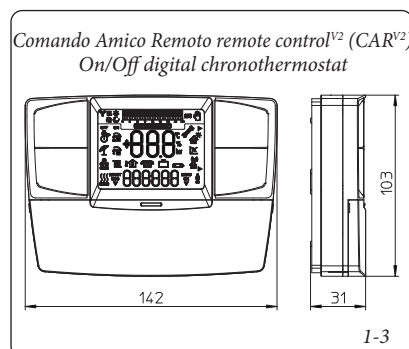

“Comando Amico Remoto” Remote control Device^{v2} or On/Off chronothermostat electrical connections (Optional). *The operations described below must be performed after having removed the voltage from the appliance.* Any thermostat or On/Off environment chronothermostat must be connected to clamps 40 and 41 eliminating jumper X40 (Fig. 3-2). Make sure that the On/Off thermostat contact is of the “clean” type, i.e. independent of the mains supply, otherwise the electronic adjustment card would be damaged. Any Comando Amico Remoto remote control^{v2} must be connected to clamps 40 and 41 eliminating jumper X40 on the circuit board, paying attention not to invert the connections (Fig. 3-2).

Important: if the “Comando Amico Remoto” remote control^{v2} or any other On/Off chronothermostat is used arrange two separate lines in compliance with current regulations regarding electrical systems. No boiler pipes must ever be used to earth the electric system or telephone lines. Ensure elimination of this risk before making the boiler electrical connections.

1.7 EXTERNAL PROBE (OPTIONAL).

The boiler is prepared for the application of the external probe (Fig. 1-4), which is available as an optional kit.

The probe can be connected directly to the boiler electrical system and allows the max. system flow temperature to be automatically decreased when the external temperature increases, in order to adjust the heat supplied to the system according to the change in external temperature. The external probe always acts when connected independently from the presence or type of room thermostat used. The correlation between system flow temperature and external temperature is determined by the position of the selector switch on the boiler control panel according to the curves shown in the diagram (Fig. 1-5). The electric connection of the external probe must be made on clamps 38 and 39 on the boiler P.C.B. (Fig. 3-2).

1.8 VENTILATION OF THE ROOMS.

In the room in which the boiler is installed it is necessary that at least as much air flows as that requested for by normal combustion of the gas and ventilation of the room. Natural air flow must take place directly through:

- permanent openings in the walls of the room to ventilate that lead towards the outside;
- condotti di ventilazione, singoli oppure collettivi ramificati.

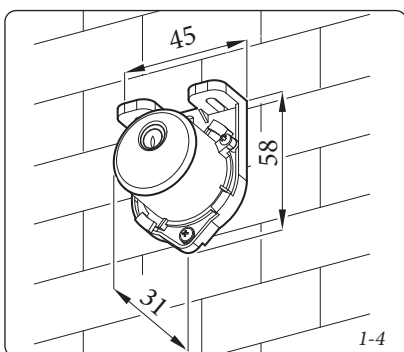

The air used for ventilation must be withdrawn directly from outside, in an area away from sources of pollution. Natural air flow is also allowed indirectly by air intake from adjoining rooms. For further information relative to ventilation of the rooms follow that envisioned in the regulation.

Evacuation of foul air. In the rooms where the gas appliances are installed it may also be necessary, as well as the intake of combustion agent air, to evacuate foul air, with consequent intake of a further equal amount of clean air. This must be realised respecting the provisions of the technical regulations in force.

1.9 FLUE DUCTS.

The gas appliances with attachment for the flues discharge pipe must have direct connection to chimneys or safely efficient flues.

Only if these are missing can the combustion products be discharged directly to the outside, as long as the standard regulations for the flue terminal are respected as well as the existing laws.

Connection to chimneys or flues. The connection of the appliances to a chimney or flue takes place by means of flue ducts.

In the case of connection to pre-existing flues, these must be perfectly clean as the slag, if present, on detachment from the walls during functioning, could obstruct the passage of flue gas, causing extremely dangerous situations for the user.

The flue ducts must be connected to the chimney or flue in the same room in which the appliance is installed or, at most, in the adjoining room and must comply with the requisites of this regulation.

1.10 FLUES/CHIMNEYS.

For the appliances with natural draught individual chimneys and branched flues can be used.

Individual chimneys. The internal dimensions of some types of individual chimneys are contained within the prospects of the regulation. If the effective system data do not fall within the conditions of applicability or the table limits, the size of the chimney must be calculated according to the regulation.

Branched flues. In buildings with lots of floors, branched flues can be used for the natural draught evacuation of combustion products (c.c.r.). New CCR must be designed following the calculation method and regulation standards.

Chimney caps. The cap is a device positioned crowning an individual chimney or branched

flue. This device eases the dispersion of combustion products, even in adverse weather conditions, and prevents the deposit of foreign bodies. This must satisfy the requisites of the regulation. In order to prevent the formation of counterpressures that impede the discharge of combustion products into the atmosphere, the outlet height corresponding to the top of the chimney/flue, independently of any caps, must be over the “backflow area”. It is therefore necessary to use the minimum heights indicated in the figures stated in the regulation, depending on the slope of the roof.

Direct exhaust to the outside. The natural draught appliances to be connected to a chimney or a flue can discharge the combustion products directly to the outside, through a pipe passing through the perimeter walls of the building. In this case discharge takes place through an exhaust flue, which is connected to a draught terminal at the outside.

Exhaust flue. The exhaust flue must be in compliance with the same requisites listed for the flue ducts, with further provisions stated in the regulation in force.

Positioning the draught terminals. The draught terminals must:

- be installed on external perimeter walls of the building;
- be positioned according to the minimum distances specified in current technical standards.

Flue exhaust of forced draught appliances in closed open-top environments. In spaces closed on all sides with open tops (ventilation pits, courtyards etc.), direct flue gas exhaust is allowed for natural or forced draught gas appliances with a heating power range from 4 to 35 kW, provided the conditions as per the current technical standards are respected.

Important: it is prohibited to put the flues exhaust control device out of order voluntarily. Every piece of this device must be replaced using original spare parts if they have deteriorated. In the case of repeated interventions of the flues exhaust control device, check the flues exhaust flue and the ventilation of the room in which the boiler is located.

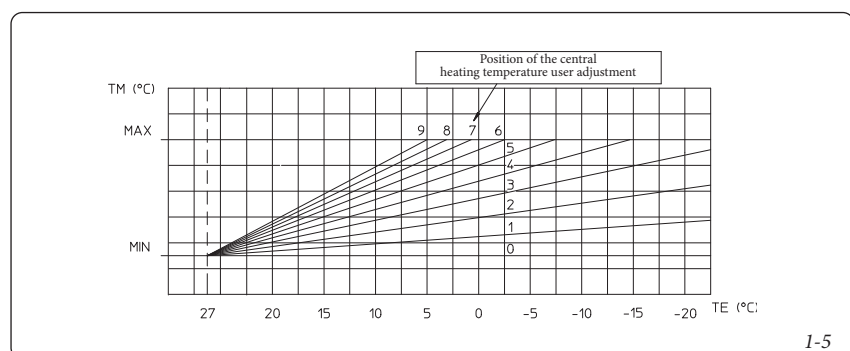

1.11 SYSTEM FILLING.

Once the boiler is connected, fill the system via the filling valve (Fig. 2-2). Filling is performed at low speed to ensure release of air bubbles in the water via the boiler and heating system vents. The boiler has a built-in automatic venting valve on the circulator. Open the radiator vent valves. Close radiator vent valves only when water escapes from them. Close the filling valve when the boiler manometer indicates approx. 1.2 bar.

N.B.: during these operations start up the circulation pump at intervals, acting on the main switch positioned on the control panel. *Vent the circulation pump by loosening the front cap and keeping the motor running.* Tighten the cap after the operation.

1.12 GAS SYSTEM START-UP.

To start up the system, refer to the technical standard in force: In particular, for new gas systems:

- open windows and doors;
- avoid presence of sparks or naked flames;
- bleed all air from pipelines;
- check that the internal system is properly sealed according to specifications.

1.13 BOILER START UP (IGNITION).

To commission the boiler (the operations listed below must only be performed by a qualified firm and without any unauthorised persons):

- check that the internal system is properly sealed according to specifications
- make sure that the type of gas used corresponds to boiler settings;
- check that there are no external factors that may cause the formation of fuel pockets;
- switch the boiler on and check correct ignition;
- make sure that the gas flow rate and relevant pressure values comply with those given in the manual (par. 3.18);
- check the correct ventilation of the rooms;
- check the existing draught during normal functioning of the appliance, e.g. a draught gauge positioned at the exit of the appliance combustion products;

- check that there is no backflow of combustion products into the room, even during functioning of fans;
- ensure that the safety device is engaged in the event of gas supply failure and check activation time;
- check activation of the main switch located upstream from the boiler.

The boiler must not be started up even if only one of the checks should be negative.

1.14 CIRCULATION PUMP.

The Mini Nike X 24 3 E series boilers are supplied with a built-in circulation pump with 3-position electric speed control. The boiler does not operate correctly with the circulation pump on first speed. To ensure optimal boiler operation, in the case of new systems (single pipe and module) it is recommended to use the pump at maximum speed. The pump is already fitted with a condenser.

Pump release. If, after a prolonged period of inactivity, the circulation pump is blocked, unscrew the front cap and turn the motor shaft using a screwdriver. Take great care during this operation to avoid damage to the motor.

By-pass regulation (part. 20 Fig. 1-7). If necessary, the by-pass can be regulated according to system requirements from a minimum (by-pass excluded) to a maximum (by-pass inserted) represented by the graphics (Fig. 1-6). Make the regulation using a flat head screwdriver, turn clockwise and insert the by-pass, anti-clockwise it is excluded.

1.15 KITS AVAILABLE ON REQUEST.

- System shut off valves kit. The boiler is designed for installation of system interception cocks to be placed on flow and return pipes of the connection assembly. This kit is particularly useful for maintenance as it allows the boiler to be drained separately without having to empty the entire system.
- Polyphosphate dispenser kit. The polyphosphate dispenser reduces the formation of lime-scale and preserves the original heat exchange and domestic hot water production conditions. The boiler is prepared for application of the polyphosphate dispenser kit.
- External storage tank unit coupling kit. If the production of DHW is required as well as room central heating, on request Immergas supplies a kit made up from an external cylinder unit and everything necessary for adaptation of the boiler

The above-mentioned kits are supplied complete with instructions for assembly and use.

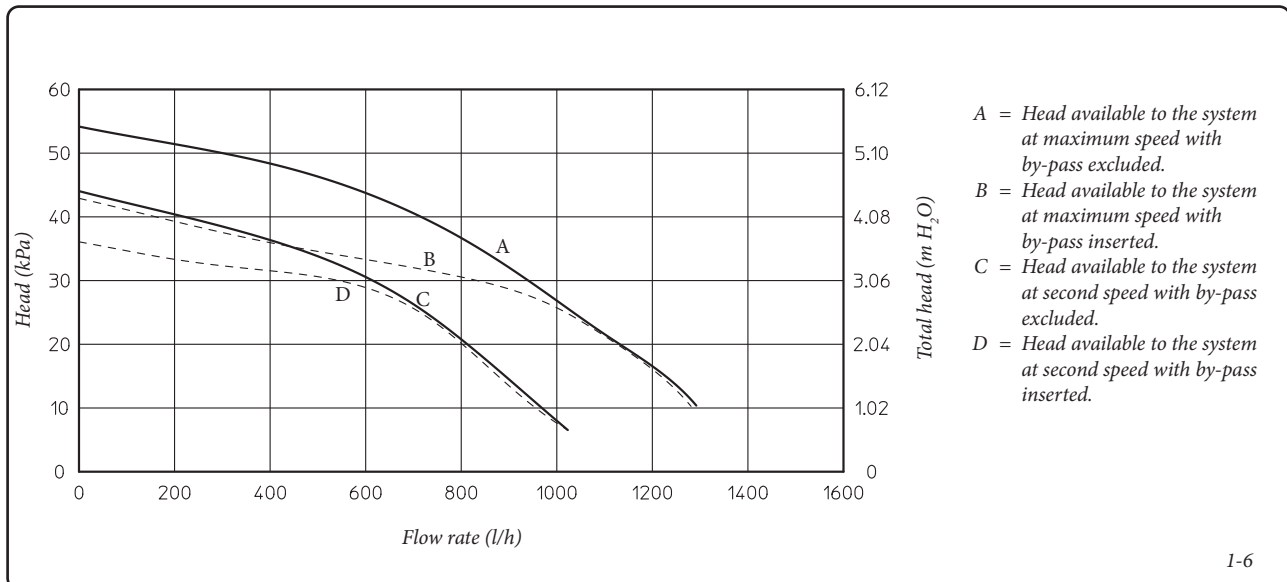
Total head available to the system.

1.16 BOILER COMPONENTS.

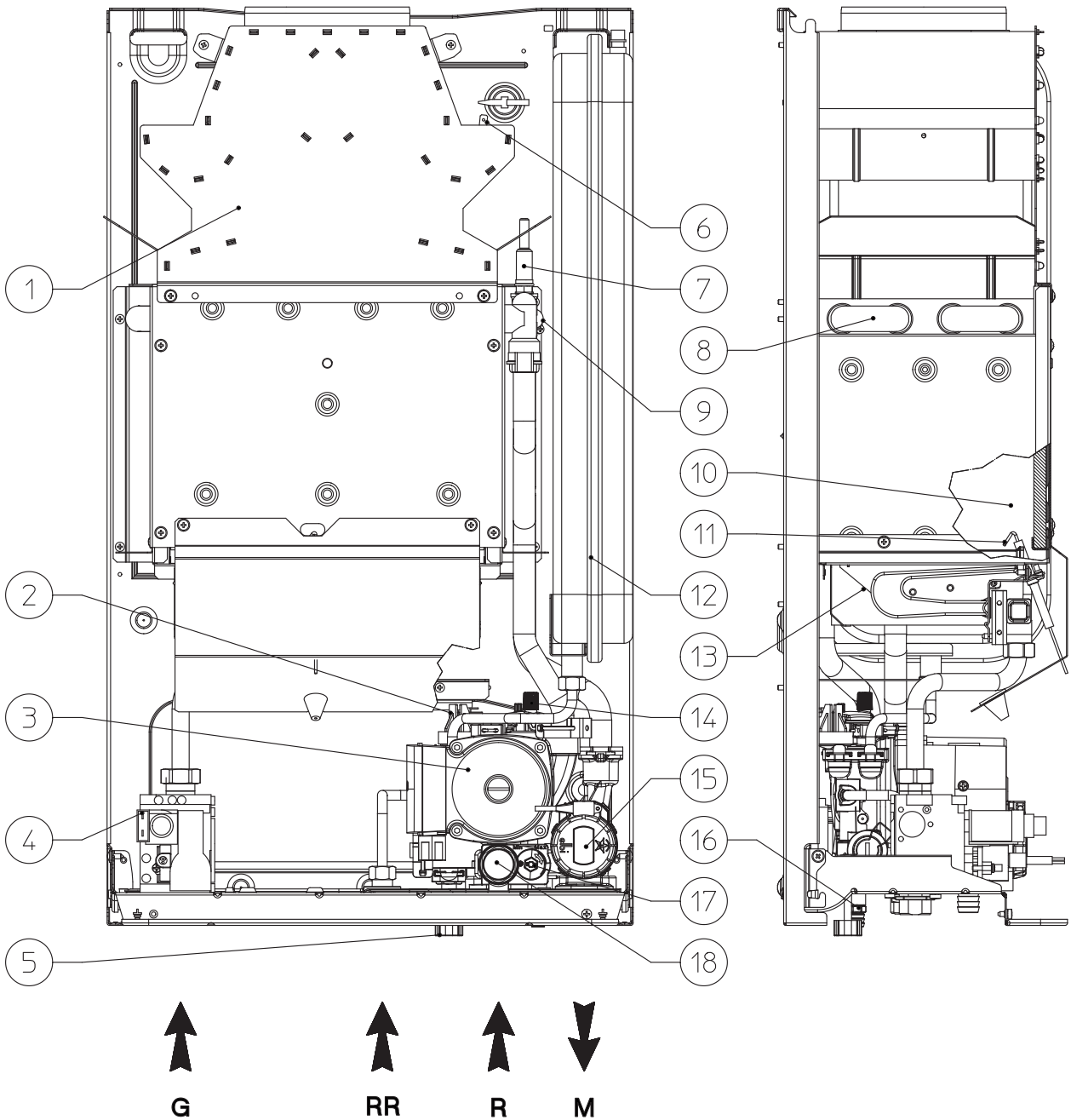

Key:

- 1 - Flue hood
- 2 - System pressure switch
- 3 - Boiler pump
- 4 - Gas valve
- 5 - System filling valve
- 6 - Flue safety thermostat
- 7 - Flow probe
- 8 - Primary heat exchanger
- 9 - Safety thermostat

- 10 - Combustion chamber
- 11 - Ignition and detection electrodes
- 12 - System expansion vessel
- 13 - Burner
- 14 - Vent valve
- 15 - Motorized three-way valve
- 16 - System draining valve
- 17 - By-pass
- 18 - 3 bar safety valve

N.B.: connection group (optional)

INSTALLATOR

USER

MAINTENANCE TECHNICIAN

2 INSTRUCTIONS FOR USE AND MAINTENANCE

2.1 CLEANING AND MAINTENANCE.

Attention: to preserve the boiler's integrity and keep the safety features, performance and reliability which distinguish it unchanged over time, maintenance operations must be carried out on a yearly basis in compliance with that stated in the "annual check and maintenance of the appliance" section, in compliance with national, regional, or local standards in force.

2.2 VENTILATION OF THE ROOMS.

In the room in which the boiler is installed it is necessary that at least as much air flows as that requested for by normal combustion of the gas and ventilation of the room. The provisions relative to ventilation, the flue pipes, chimneys and caps are stated in Par. 1.8, 1.9 and 1.10. If in doubt regarding correct ventilation, contact an authorised company

2.3 GENERAL WARNINGS.

Never expose the wall-mounted boiler to direct vapours from a cooking surface.

Use of the boiler by unskilled persons or children is strictly prohibited.

If temporary shutdown of the boiler is required, proceed as follows:

- drain the heating system if anti-freeze is not used;
- shut-off all electrical, water and gas supplies.

In the case of work or maintenance to structures near ducting or devices for flue extraction and the relative accessories, switch off the appliance and on completion of the operations make sure that an authorised company verifies the efficiency of the ducting or the devices.

Never clean the appliance or connected parts with easily flammable substances.

Never leave containers or flammable substances in the same environment as the appliance.

It is prohibited and dangerous to obstruct the air intake, even partially, for the ventilation of the room in which the boiler is installed.

Due to the danger, operation is also prohibited in the same room as suction devices or the like, at the same time as the boiler unless there are additional openings dimensioned in a way to satisfy the additional requirement for air. For the dimensioning of these additional openings, refer to an authorised company.

• **Important:** the use of components that employ electrical power requires some fundamental rules to be observed:

- do not touch the appliance with wet or moist parts of the body; do not touch when bare-foot;
- never pull electrical cables or leave the appliance exposed to atmospheric agents (rain, sunlight, etc.);
- the appliance power cable must not be replaced by the user;
- if the cable is damaged, switch off the appliance and solely contact an authorised company to replace it;

- if the appliance is not to be used for a certain period, disconnect the main power switch.

N.B.: the temperatures indicated by the display have a tolerance of +/- 3°C due to environmental conditions that cannot be attributed to the boiler.

At the end of its service life the appliance must not be disposed of like normal household waste nor abandoned in the environment, but must be removed by an authorised company. Contact the manufacturer for disposal instructions.

2.4 CONTROL PANEL.

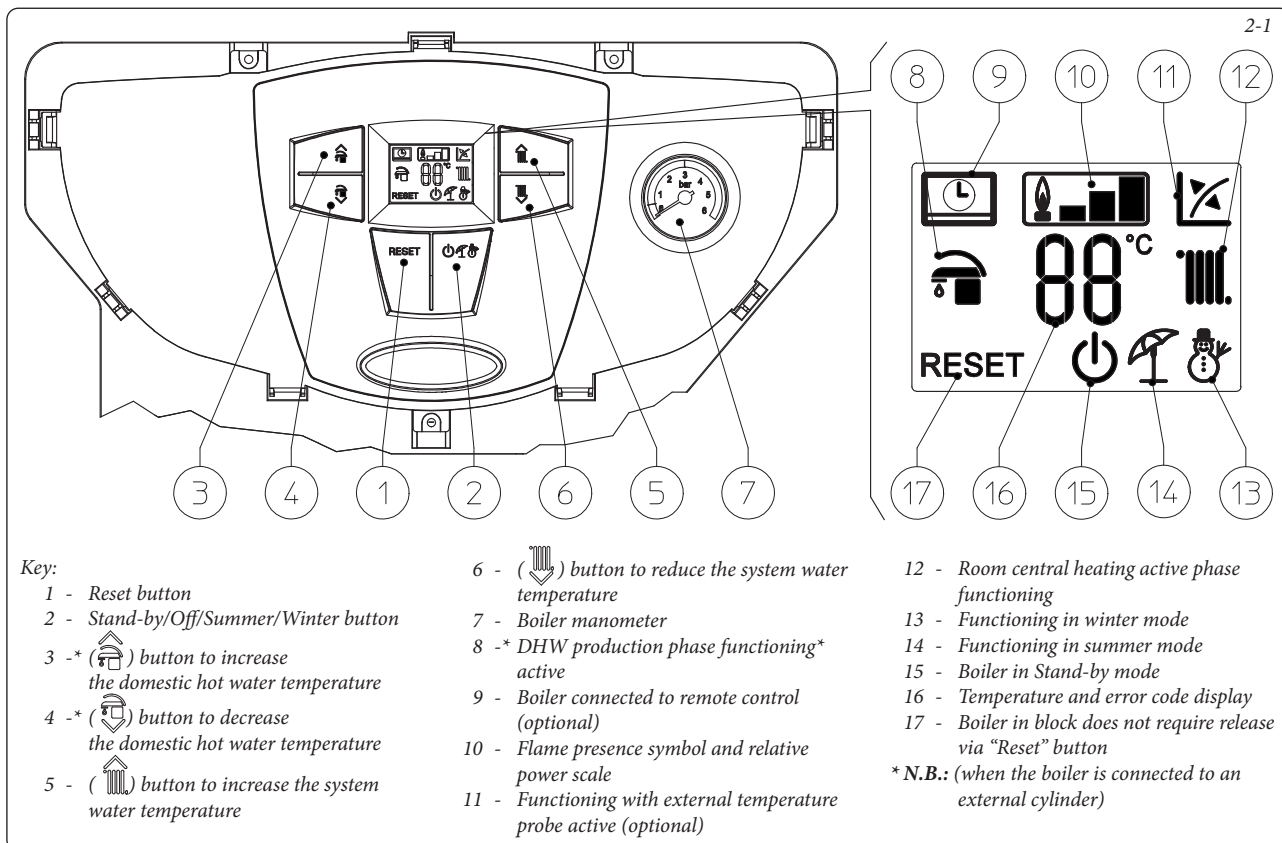

2.5 USING THE BOILER.

Important: the Mini Nike X 24 3 E boiler has been designed to operate as an appliance for room central heating only or, coupled to a specific optional kit, for central heating and the production of DHW. For this reason the boiler control panel has a button to adjust the temperature of DHW, but its operation is only activated by the optional kits that also enable the production of DHW. Without the coupling of these specific kits, the functioning of this button and all functions referring to the DHW are inhibited.

Before ignition, make sure the heating system is filled with water and that the manometer (7) indicates a pressure of 1 ÷ 1.2 bar.

- Open the gas cock upstream from the boiler.
- Press the button (2) until the display switches on, after which press the button in sequence (2) and take the boiler to the summer (☀) or winter (❄) position.
- **Summer (☀):** in this mode the boiler functions only to produce the DHW (*when the boiler is connected to an external cylinder*), the temperature is set via the buttons (3-4) and the relative temperature is shown on the display via the indicator (16).
- **Winter (❄):** in this mode the boiler functions both for producing domestic hot water (*when the boiler is connected to an external cylinder*) and heating the environment. The temperature of the DHW is always regulated via buttons (3-4), the heating temperature is regulated via buttons (5-6) and the relative temperature is shown on the display via the indicator (16).

From this moment the boiler functions automatically. With no demand for heat (heating or domestic hot water production) the boiler goes to “standby” function, equivalent to the boiler being powered without presence of flame. Each time the burner ignites, the relative flame present symbol is displayed (10) with relative power scale.

- **Operation with Comando Amico Remoto remote control^{v2} (CAR^{v2}) (Optional).** If the CAR^{v2} is connected, the (☺) symbol will appear on the display. The boiler regulation parameters can be set via the CAR^{v2} control panel and the reset button (1) remains active on the boiler control panel, along with the switch-off button (2) (“off” mode only) and the display where the functioning state is shown.

Important: if the boiler is put into “off” mode on the CAR^{v2} the “CON” connection error symbol will appear on the CAR. The CAR^{v2} is however powered constantly so as not to lose memorised programs.

- **Functioning with optional external probe (⚡).** In the case of a system with optional external probe, the boiler flow temperature for room central heating is managed by the external probe depending on the external temperature measured (Par. 1.8). The flow temperature can be modified by selecting the functioning curve via buttons (5 and 6), selecting a value from “0 to 9” (Fig. 1-5).

With external probe present, the relative symbol will appear on the display (12). In the central heating phase, if the temperature of the water contained in the system is sufficient to heat the radiators, the boiler can only function with the activation of the pump.

- **“Stand-by” mode.** Press button (2) in succession until the (☺) symbol appears. The boiler remains active from this moment and the anti-freeze function, pump anti-block function and 3-way and signalling of any anomalies is guaranteed.

N.B.: in these conditions the boiler is considered still live.

- **“Off” mode.** By holding the button (2) down for 8 seconds, the display switches-off and the boiler is off completely. The safety functions are not guaranteed in this mode.

N.B.: in these conditions the boiler is considered still live even if there are no functions active.

- **Display functioning.** The display lights up during the use of the control panel, after 15 seconds inactivity, the brightness drops until just the active symbols are displayed. The lighting mode can be varied via parameter P2 in the circuit board customisation menu.

2.6 TROUBLESHOOTING.

The boiler signals out anomalies by flashing on the display and relative error codes, listed on the table, are displayed. The boiler signals out anomalies by flashing on the display and relative error codes, listed on the table, are displayed. On the remote control, the error code will be displayed by means of the same numeric code represented according to the following example

(e.g. CAR^{v2} = Exx).

Code Error	Anomaly signalled	Cause	Boiler status / Solution
01	No ignition block	In the event of a request for room central heating or domestic hot water production, the boiler does not switch on within the preset time. Upon the first ignition or after prolonged downtime of the appliance, an intervention may be required to eliminate the block.	Press the Reset button (1)
02	Thermostat safety (safety unit) over-temperature check anomaly flame	During normal operation, if a fault causes excessive internal overheating, the boiler blocks.	Press the Reset button (1)
03	Thermostat anomaly flue gas	The fume evacuation pipe does not function correctly..	The boiler goes in stand-by for 30 minutes after which, if the normal operating conditions are restored, it restarts without having to be reset. If 3 consecutive blocks occur, the boiler blocks and it must be reset for it to restart. (1)
04	General fault boiler board	Incorrect recognition of a signal by the microprocessor of the boiler board.	Press the Reset button (1)
05	Probe anomaly Flow	The board detects an anomaly on the flow probe.	The boiler does not start (1)
(1) If the shutdown or fault persists, contact an authorised firm (e.g. Authorised Technical After-Sales Service).			

Code Error	Anomaly signalled	Cause	Boiler status / Solution
08	Maximum N° of resets	Number of allowed resets that have already been performed.	Attention: the anomaly can be reset up to 5 consecutive times, after which the function is inhibited for at least an hour and one attempt is gained every hour for a maximum of 5 attempts. By switching the appliance on and off, the 5 attempts are re-acquired.
10	Insufficient system pressure	Insufficient water pressure inside the central heating circuit is detected, which guarantees correct boiler operation.	Verify that the system ranges between 1÷1.2 bar on the manometer and if necessary restore the correct pressure.
12	Storage tank probe anomaly	The board detects an anomaly on the storage tank probe.	The boiler cannot produce domestic hot water (1).
15	Configuration error	If the board detects an anomaly or incongruity on the electric wiring, the boiler will not start.	If the normal operating conditions are restored, the boiler restarts without having to be reset. (1)
20	Parasite flame	This occurs in the event of a leak in the detection circuit or an anomaly in the flame control unit.	Press the Reset button (1)
24	Push button control panel anomaly	The board detects an anomaly on the pushbutton panel.	If the normal operating conditions are restored, the boiler restarts without having to be reset (1)
27	Insufficient circulation	This occurs if there is overheating in the boiler due to insufficient water circulating in the primary circuit; the causes may be: - poor system circulation; check that there is no interception on the closed heating circuit and that the system is perfectly free of air (deaerated); - blocked pump; free the pump.	Press the Reset button (1).
31	Loss of remote control communication	This occurs if communication is lost between the boiler and the CAR ^{v2} .	Disconnect and reconnect the power to the boiler (1).
37	Low power supply voltage	This occurs when the power supply voltage is lower than the allowed limits for the correct boiler operation.	If the normal operating conditions are restored, the boiler restarts without having to be reset (1).
(1) If the shutdown or fault persists, contact an authorised firm (e.g. Authorised Technical After-Sales Service).			

Code Error	Anomaly signalled	Cause	Boiler status / Solution
38	Loss of flame signal	If the pressure is below 1 bar (with the circuit cool) restore normal pressure via the cock located in the lower part of the boiler (Fig. 2-2). This occurs when the boiler is on correctly and the flame of the burner is switched off unexpectedly. The cock can be operated if performed correctly. If pressure and controls are restored, the boiler does not have to be reset.	water heating system in zones where the temperature falls below 0°C. In the case of prolonged inactivity, the central heating system is protected using anti-freeze liquid. In the case of prolonged inactivity, the central heating system is protected using anti-freeze liquid. In the case of prolonged inactivity, the central heating system is protected using anti-freeze liquid. In the case of prolonged inactivity, the central heating system is protected using anti-freeze liquid.
43	Block due to of the continuous flame signal	In this case, remove water from an air vent valve of a radiator until 1 bar is reached or ask for assistance from an authorised company. "Flame signal loss" error occurs 6 consecutive times (38).	- the central heating circuit and boiler domestic hot water circuit must be drained. In systems that are drained frequently, filling must be carried out with suitably treated water to eliminate hardness that can cause lime-scale.

(1) If the shutdown or fault persists, contact an authorised firm (e.g. Authorised Technical After-Sales Service).

2.7 BOILER SHUTDOWN.

For complete boiler switch-off, press the "off" button, disconnect the onnipolar switch outside of the boiler and close the gas cock upstream from the appliance. Never leave the boiler switched on if left unused for prolonged periods.

2.8 RESTORE CENTRAL HEATING SYSTEM PRESSURE.

Periodically check the system water pressure. The boiler pressure gauge should read a pressure between 1 and 1.2 bar.

qualified staff for assistance to eliminate the possible system leakage.

2.9 SYSTEM DRAINING.

To drain the boiler, use the special draining valve (Fig. 2-2)
Before draining, ensure that the filling valve is closed.

2.10 ANTI-FREEZE PROTECTION.

The boiler has an anti-freeze function that switches on automatically when the temperature falls below 4°C (standard protection to minimum temperature of -5°C). In order to guarantee the integrity of the appliance and the domestic hot

2.11 CASE CLEANING.

Use damp cloths and neutral detergent to clean the boiler casing. Never use abrasive or powder detergents.

2.12 DECOMMISSIONING.

In the event of permanent shutdown of the boiler, contact professional staff for the procedures and ensure that the electrical, water and gas supply lines are shut off and disconnected.

Bottom view.

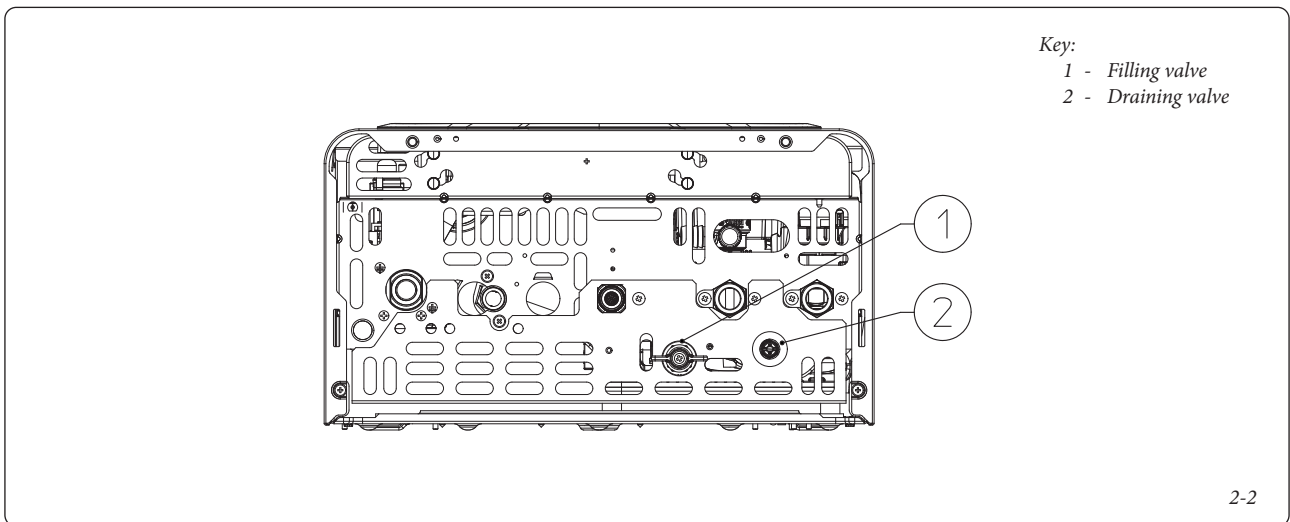

3 BOILER START-UP (INITIAL CHECK).

To commission the boiler:

- make sure that the type of gas used corresponds to boiler settings;
- check connection to a 230V-50Hz power mains, correct L-N polarity and the earthing connection;
- make sure the central heating system is filled with water and that the manometer indicates a pressure of 1 ± 1.2 bar.
- switch the boiler on and check correct ignition;
- make sure the gas maximum, intermediate and minimum flow rate and pressure values correspond to those given in the handbook, Par. 3.18;
- check activation of the safety device in the event of no gas, as well as the relative activation time;
- check activation of the main switch located upstream from the boiler;
- check the existing draught during normal functioning of the appliance, e.g. a draught gauge positioned at the exit of the appliance combustion products;
- check that there is no backflow of combustion products into the room, even during functioning of fans;
- ensure activation of all adjustment devices;
- seal the gas flow rate regulation devices (if settings are modified);
- check the production of domestic hot water (when the boiler is connected to an external cylinder);
- check sealing efficiency of water circuits;
- check ventilation and/or aeration of the installation room where provided.

If any checks/inspection give negative results, do not start the boiler.

3.1 HYDRAULIC DIAGRAM.

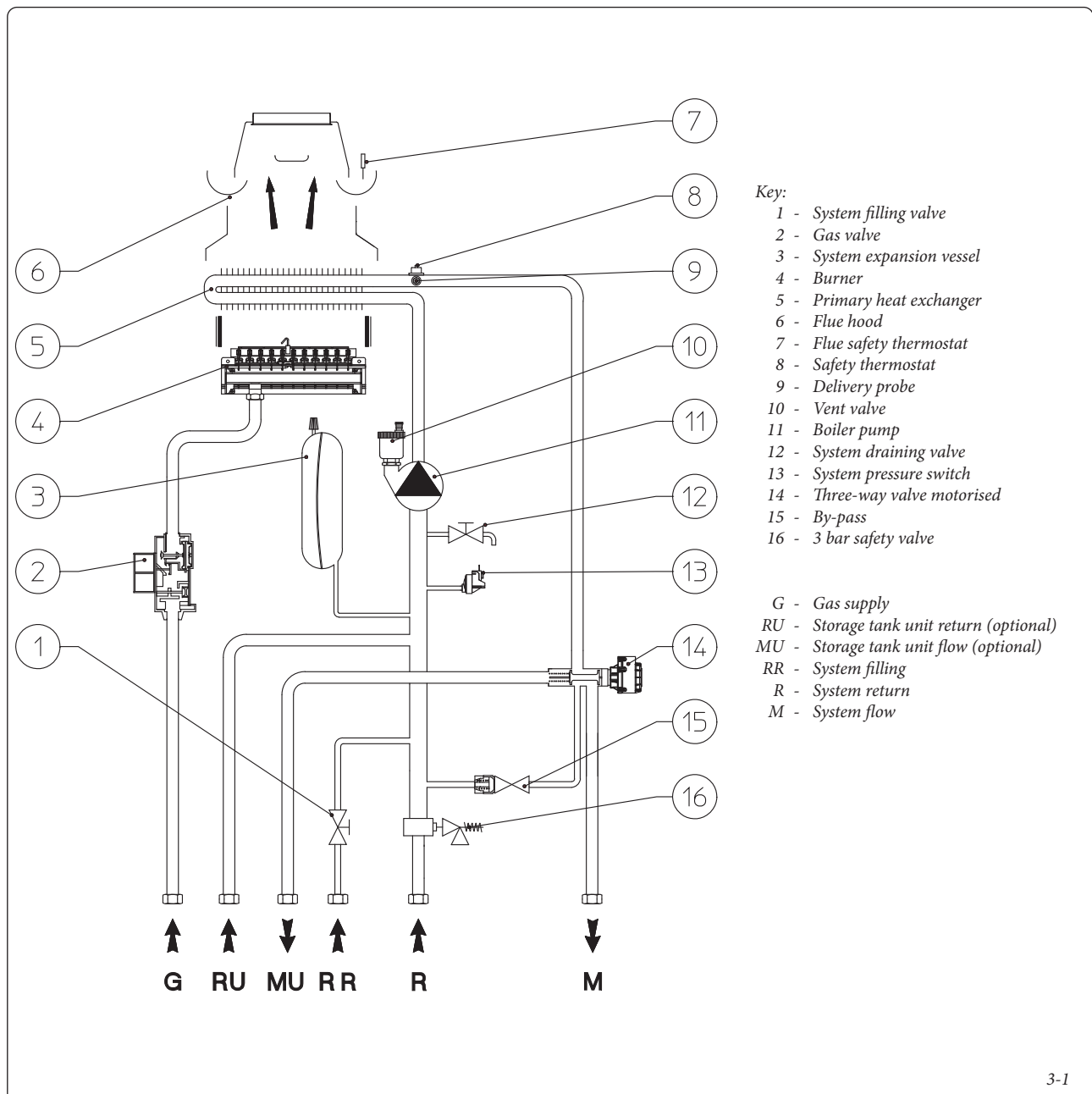

3.2 WIRING DIAGRAM.

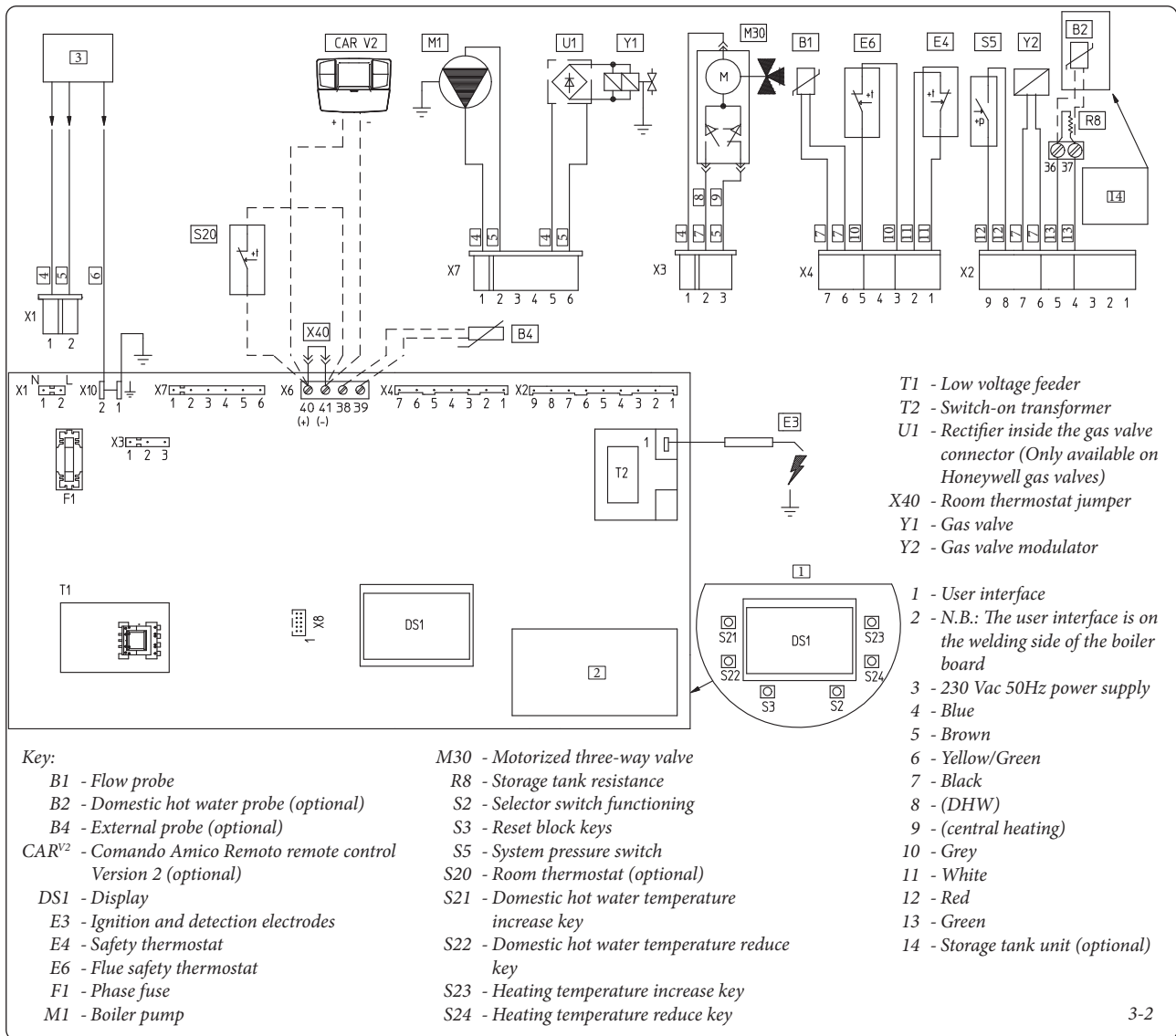

The boiler is designed for application of a room thermostat (S20), an On/Off room chronothermostat, a program timer or a Comando Amico Remoto remote control^{V2} (CAR^{V2}). Connect to clamps 40 - 41 eliminating the jumper X40, paying attention not to invert the polarity if the CAR^{V2} is installed.

Cylinder unit: the boiler is prepared for the application of a storage tank unit, which must be connected to clamps 36 and 37 of the bipolar terminal board positioned under the sealed chamber, eliminating resistance R8.

The connector X3 is present in the boiler but must be connected only if the storage tank unit is present.

The connector X8 is used for the connection of the Virgilio Palmtop in the microprocessor software updating operation.

The DHW probe must be connected to terminals 36 and 37 eliminating the resistance R8.

3.3 TROUBLESHOOTING.

N.B.: maintenance operations must be carried out by an authorised company (e.g. After-Sales Technical Assistance Service).

- Smell of gas. Caused by leakage from gas circuit pipelines. Check sealing efficiency of gas intake circuit.
- Irregular combustion (red or yellow flame). When the burner is dirty or the boiler lamellar pack is blocked. Clean the burner or the boiler lamellar pack.
- Frequent interventions of the over heating safety thermostat. It can depend on the lack of water in the boiler, little water circulation in the system or blocked pump. Check on the manometer that the system pressure is within established limits. Check that the radiator valves are not closed and also the functionality of the pump.
- The boiler produces condensate. This can be caused by obstructions of the chimney or flues with height or section not proportioned to the boiler. It can also be determined by functioning at boiler temperatures that are excessively low. In this case, make the boiler run at higher temperatures.

- Frequent interventions of the flue safety thermostat This can be caused by obstructions in the flue gas circuit. Check the flue. The flue may be obstructed or by height or section not suitable for the boiler. Ventilation may be insufficient (see room ventilation point).
- Presence of air in the system. Check opening of the hood of the special air vent valve (Fig. 1-7). Make sure the system pressure and expansion vessel pre-charge values are within the set limits; the pre-charge value for the expansion vessel must be 1.0 bar, and system pressure between 1 and 1.2 bar.
- Ignition block and Chimney block. (See par. 2.6 and 1.5 (electric connection)).

INSTALLATOR

USER

MAINTENANCE TECHNICIAN

3.4 INFORMATION MENU.

Pressing the buttons (3 and 4) for 5 seconds, the "Information menu" is activated, which allows to display some boiler functioning parameters. To scroll through the various parameters, press (3 and 4), to exit from the menu press buttons (3 and 4) again for 5 seconds or press button (2) for 5 seconds or wait for 60 seconds.

List of parameters.

N° parameter	Description
d1	Displays the flame signal (uA).
d2	Displays the primary exchanger output instant heating flow temperature.
d3	Displays the instant output temperature from the DHW exchanger.
d4	Displays the temperature set for the central heating set (if remote control is present).
d5	Displays the temperature set for the DHW set (if remote control is present).
d6	Displays the external environment temperature (if the external probe is present). If the temperature is below zero, the value is displayed flashing.

3.5 PROGRAMMING THE P.C.B.

The boiler is prepared for possible programming of several operation parameters. By modifying these parameters as described below, the boiler can be adapted according to specific needs.

To access the programming phase, proceed as follows:

- press buttons (1) and (2) at the same time for approximately 8 seconds;
- Using buttons (3) and (4), select the parameter to be changed indicated in the following table:

List of parameters	Description
P1	Boiler mode (DO NOT USE)
P2	Display lighting
P3	DHW thermostat (when the boiler is connected to an external cylinder)
P4	Minimum CH output
P5	Maximum CH output
P6	Central heating ignitions timer
P7	Central heating ramp timer
P8	Heating switch-on delay request from room thermostat and remote control
P9	Solar mode

- adjust the corresponding value consulting the table using buttons (5) and (6);

- confirm the set value pressing the Reset button (1) for approximately 3 seconds; by pressing keys (3) and (4) at the same time exit the function without memorising the modifications made.

N.B.: after a period of time, without touching any keys, the operation cancels automatically.

Boiler mode. It establishes whether the boiler functions in instant or storage mode.

Boiler mode (P1)	
Range of values which can be set	Standard setting
0 - instant boiler	1
1 - boiler with storage tank	

Lighting display. Determining how to display illumination .

Display lighting (P2)	
Range of values which can be set	Standard setting
0 - Off	1
1 - Auto	
2 - On	

- **Off:** the display is always lit with low intensity.

- **Auto:** the display lights up during use and lowers after 15 seconds of inactivity. In the case of anomaly the display flashes.

- **On:** the display is always lit with high intensity.

DHW thermostat. With the setting of the domestic hot water thermostat on "Hysteresis 1" the boiler ignites to heat the domestic hot water when the water contained in the storage tank unit falls by 3°C with respect to the temperature set, while on "Hysteresis 2" ignition takes place when the water contained in the storage tank unit falls by 10°C with respect to the temperature set.

DHW thermostat (P3)	
Range of values which can be set	Standard setting
0 - Hysteresis 1 (Standard setting)	0
1 - Hysteresis 2	

Heating output. The boiler also has electronic modulation that adapts the boiler potentiality to the effective heating demand of the house. Then the boiler works normally in a variable gas pressure field between the minimum heating power and the maximum heating power depending on the system's heating load.

N.B.: the boiler is produced and calibrated in the central heating phase at nominal output. Approximately 10 minutes are needed to reach the nominal heat output, which can be changed using the parameter (P5).

N.B.: the selection of the "Minimum heating power" and "Maximum heating power" parameters, in the presence of a heating request, allows switch-on of the boiler and power supply of the modulator with current equal to the value of the respective set value.

Minimum central heating output (P4)	
Range of values which can be set	Standard setting
0 - 63 %	Set according to factory inspection

Maximum heating output (P5)	
Range of values which can be set	Standard setting
0 - 99 %	99

Central heating ignitions timer. The boiler has electronic timing, which prevents the burner from igniting too often in central heating mode.

Central heating ignitions timer (P6)	
Range of values which can be set	Standard setting
0 - 20 (0 - 10 minutes) (01 equals 30 seconds)	6 (3')

Central heating ramp timing. In the ignition phase, the boiler performs an ignition ramp in order to arrive at the maximum power set.

Central heating ramp timer (P7)	
Range of values which can be set	Parameter
0 - 28 (0 - 14 minutes) (01 equals 30 seconds)	28 (14')

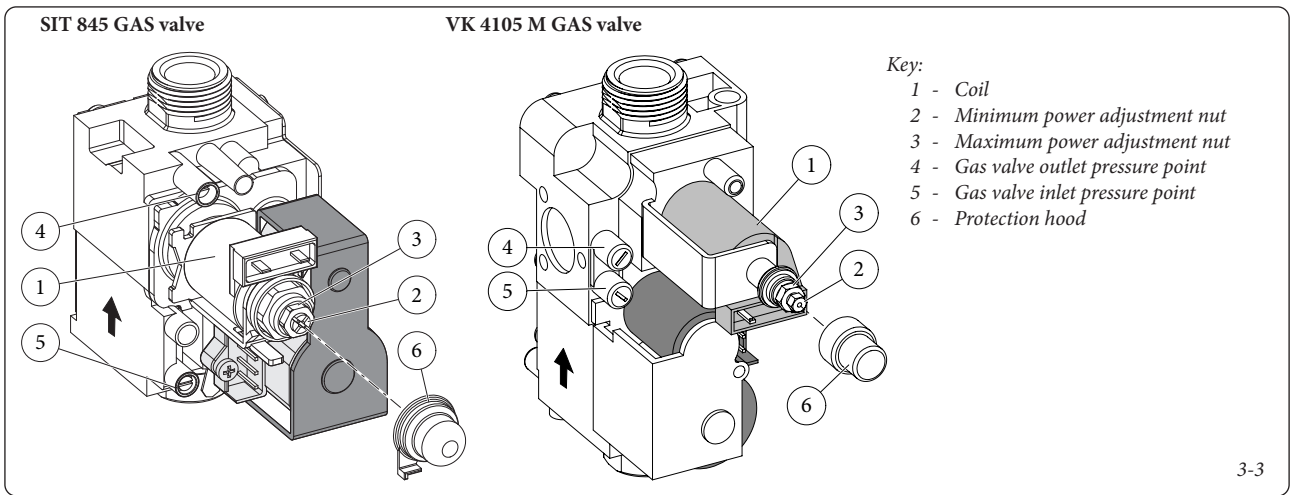

Heating switch-on delay request from room thermostat and remote control. The boiler is set to switch-on immediately after a request. In the case of particular systems (e.g. area systems with motorised thermostatic valves etc.) it could be necessary to delay switch-on.

Heating switch-on delay request from room thermostat and remote control (P8)	
Range of values which can be set	Parameter
0 - 20 (0 - 10 minutes) (01 equals 30 seconds)	0 (0')

DHW ignition delay. This function does not affect the correct functioning of this boiler model.

Solar mode (P9)	
Range of values which can be set	Standard setting
0 - 20 seconds	0

Gas type selection. The setting of this function is used to adjust the boiler in order to function with the correct type of gas.

To access this regulation, once having entered the programming mode, press the button (2) for 4 seconds. To exit, press button (2) again 4 seconds.

Gas type selection (G1)	
Range of values which can be set	Standard setting
nG - Methane lG - LPG Ci - China	The same as the type of gas being used

Ignition power (G2)	
Range of values which can be set	Standard setting
0 - 70 %	Set according to factory inspection

3.6 CONVERTING THE BOILER TO OTHER TYPES OF GAS.

If the boiler has to be converted to a different gas type to that specified on the data plate, request the relative conversion kit for quick and easy conversion.

The gas conversion operation must be carried out by an authorised company (e.g. After-Sales Technical Assistance).

To convert to another type of gas the following operations are required:

- remove the voltage from the appliance;
- replace the main burner injectors, making sure to insert the special seal rings supplied in the kit, between the gas manifold and the injectors;
- apply voltage to the appliance;
- use the boiler push button control panel to select the gas parameter type (G1) and select (Ng) in case of Methane supply or (Lg) in the case of LPG;
- adjust the boiler nominal heat output;
- adjust the boiler minimum heat power;
- adjust the boiler nominal heat output in heating phase;
- adjust (eventually) the maximum heating power;
- seal the gas flow rate regulation devices (if settings are modified);
- after completing conversion, apply the sticker, present in the conversion kit, near to the data-plate. Using an indelible marker pen, cancel the data relative to the old type of gas.

These adjustments must be made with reference to the type of gas used, following that given in the table (par. 3.18).

Key:

- 1 - Coil
- 2 - Minimum power adjustment nut
- 3 - Maximum power adjustment nut
- 4 - Gas valve outlet pressure point
- 5 - Gas valve inlet pressure point
- 6 - Protection hood

3-3

INSTALLATOR

USER

MAINTENANCE TECHNICIAN

3.8 POSSIBLE ADJUSTMENTS.

N.B.: to adjust the gas valve, remove the plastic cap (6); after adjusting, refit the cap.

- Preliminary calibration operations.
 - Set parameter P4 at 0 %.
 - Set parameter P5 at 99 %.
- Activate the chimney sweep function.
 - Enter the “DHW chimney sweep” mode, opening a DHW cock.

Important: if the boiler is set-up only for central heating, calibrate with chimney sweep in “central heating” mode.

- Adjustment of boiler nominal thermal heat output.

- Set the maximum output (99%) using the buttons (5 and 6 Fig. 2-1).

- Adjust the boiler nominal power on the brass nut (3 Fig. 3.3), keeping to the maximum pressure values stated in the tables (Par. 3.18) according to the type of gas; by turning clockwise the heat potential increases, anti-clockwise it decreases.

- Adjustment of boiler minimum thermal heat output.

N.B.: only proceed after having calibrated the nominal pressure.

- Set the minimum output (0%) always using the buttons (5 and 6 Fig. 2-1).

- Adjust the minimum thermal input by operating on the cross plastic screws (2) on the gas valve maintaining the brass nut blocked (3);

- Exit the “Chimney sweep” mode and keep the boiler functioning.

- Adjustment of the boiler minimum heat output in heating phase.

N.B.: only proceed after having calibrated the minimum boiler pressure.

- To adjust the minimum heat output during the heating phase, change parameter (P4), increasing the value the pressure increases, reducing it the pressure drops.

- The pressure to which the boiler minimum heat output must be adjusted, must not be lower than that stated in the tables (Par. 3.18).

- Adjustment (any) of the boiler maximum heat output in heating phase.

- To adjust the maximum heat output during the heating phase, change parameter (5), increasing the value the pressure increases, reducing it the pressure drops.



- The pressure to which the boiler maximum heat output must be adjusted in central heating phase, must not be carried out in reference to that stated in the tables (Par. 3.18).



3.9 AUTOMATIC SLOW IGNITION FUNCTION WITH TIMED RAMP DELIVERY.

In ignition phase, the P.C.B. supplies constant gas with pressure proportional to the parameter “G2” set.

3.10 CHIMNEY SWEEP” FUNCTION.

When activated, this function forces the boiler to variable output for 15 minutes.

In this state all adjustments are excluded and only the safety thermostat and the limit thermostat remain active. To activate the chimney sweep function, press the Reset button (1) for 8 seconds in absence of DHW requests, its activation is signalled by the indication of the flow temperature and the flashing  and  symbols.

This function allows the technician to check the combustion parameters. Once the function is activated, it is possible to select whether to perform the check in CH status, regulating the parameters with buttons (5 and 6) or in DHW mode opening any DHW cock and always regulate the parameters with the buttons (5 and 6). Functioning in CH or DHW mode is visualised by the relative flashing  or  symbols.

On completion of the checks, deactivate the function by pressing the Reset button (1) for 8 seconds.

3.11 PUMP ANTI-BLOCK FUNCTION.

The boiler has a function that starts the pump once every 24 hours for the duration of 30 seconds in order to reduce the risk of the pump becoming blocked due to prolonged inactivity.

3.12 THREE-WAY ANTI-BLOCK FUNCTION.

The boiler is supplied with a function that activates the motorises three-way unit every 24 hours, carrying out a complete cycle in order to reduce the risk of three-way block due to prolonged inactivity.

3.13 RADIATORS ANTI-FREEZE FUNCTION.

If the system return water is below 4°C, the boiler starts up until reaching 42°C.

3.14 P.C.B. PERIODICAL SELF-CHECK.

During functioning in central heating mode or with boiler in stand-by, the function activates every 18 hours after the last boiler check/power supply. In case of functioning in domestic hot water mode the self-check starts within 10 minutes after the end of the withdrawing in progress, for duration of approx. 10 seconds.

N.B.: during self-check, the boiler remains off, including signalling.

3.15 SOLAR PANELS COUPLING FUNCTION.

In the case of integration of the heating of the DHW with solar panel systems, for correct use of the boiler in this condition, it is necessary to set the parameter P3 (DHW thermostat) on “1”.

3.16 CASING REMOVAL.

To facilitate boiler maintenance the casing can be completely removed as follows: (Fig. 3-4 / 3-5):

- 1 Unhook the decorative frame (a) from the relative lower retainers.
- 2 Remove the decorative frame (a) from the casing (c).
- 3 Loosen the 2 front screws (b) for fixing the casing.

4 Loosen the 2 lower screws (d) for fixing the casing.

5 Pull the case towards yourself (c).

6 Push the case (c) upwards at the same time to release it from the upper hooks.

Installation drawings key:

- a** Unmistakable component identification
- 1** Sequential identification of the operation to perform

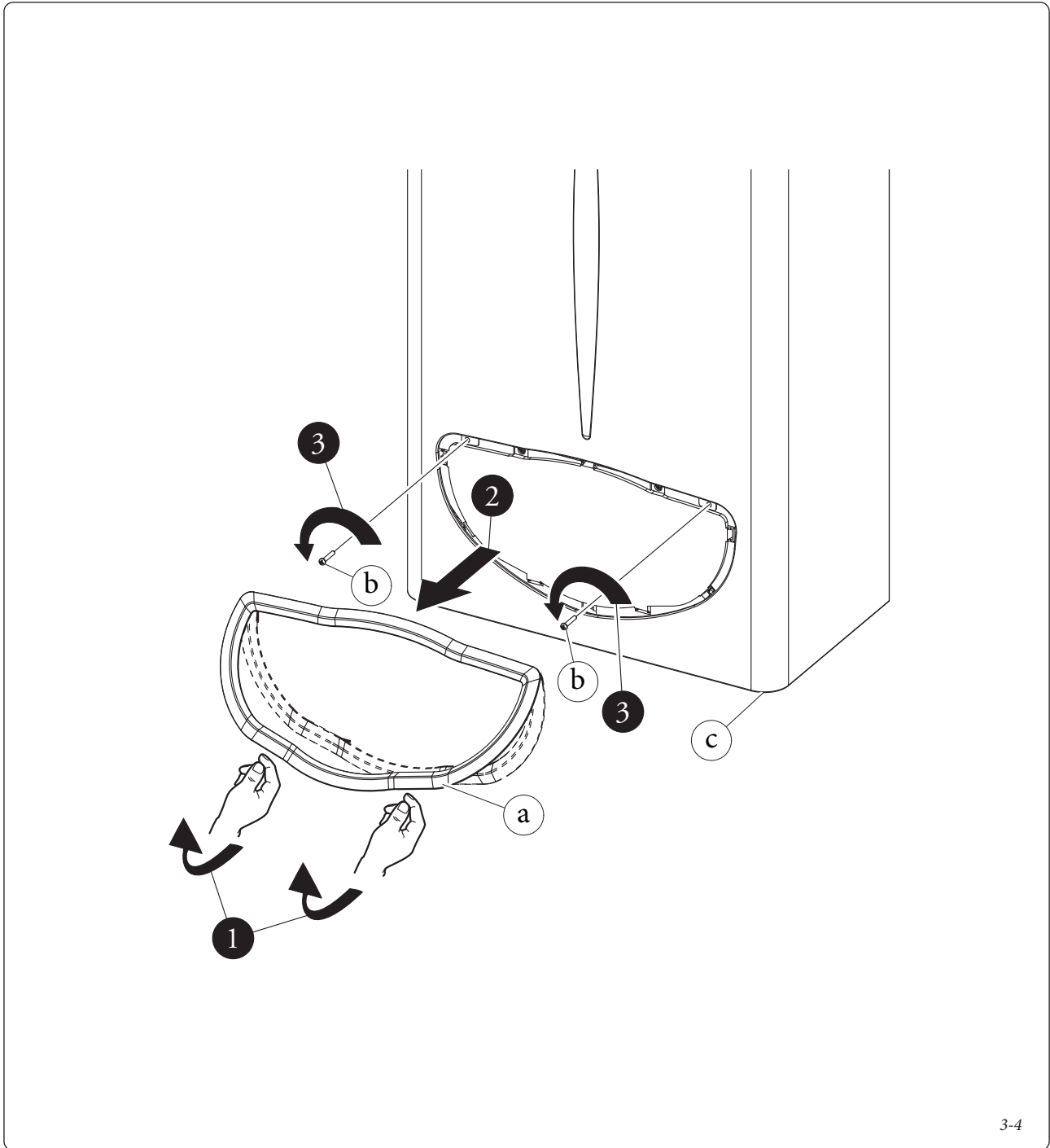

3-4

INSTALLATOR

USER

MAINTENANCE TECHNICIAN

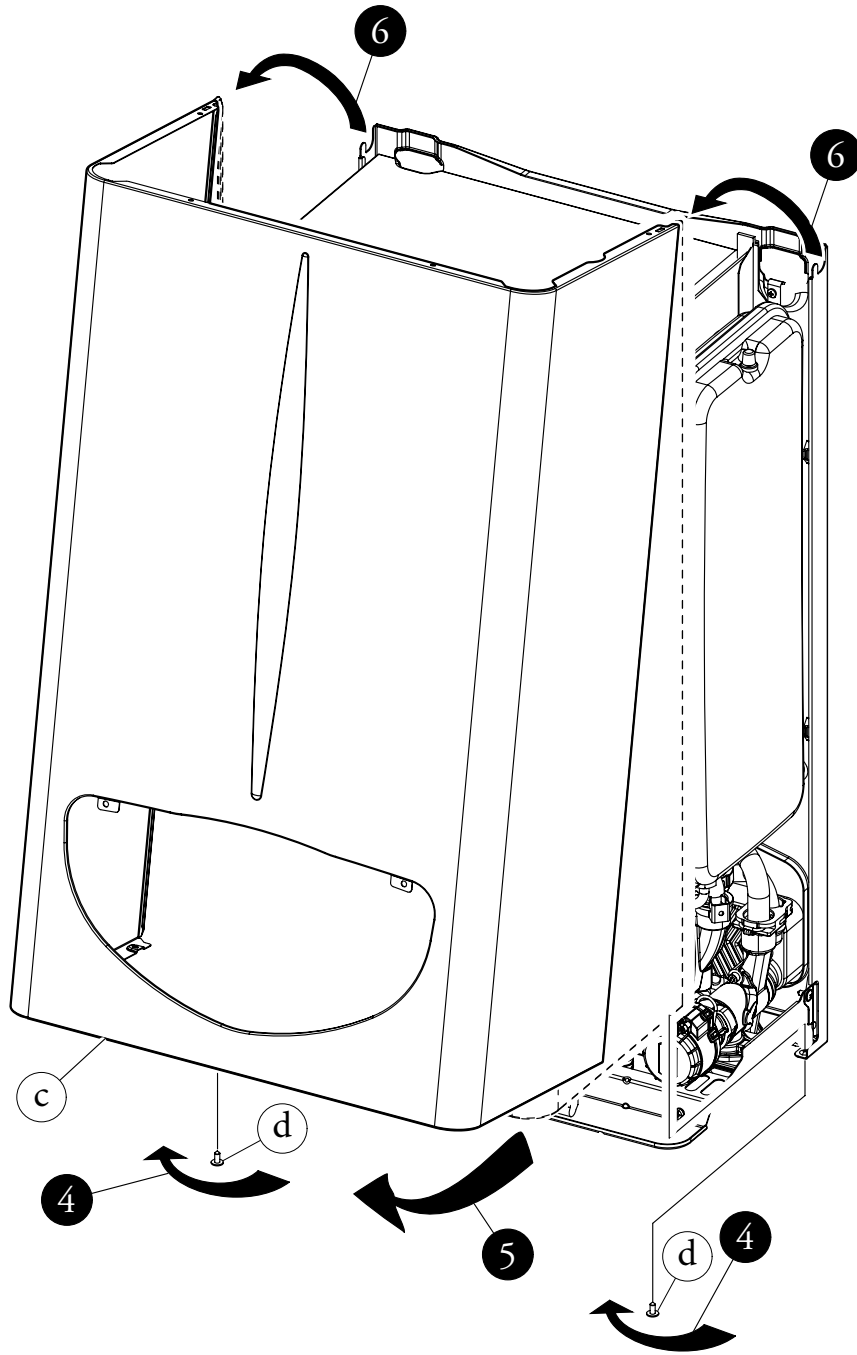

3.17 YEARLY APPLIANCE CHECK AND MAINTENANCE.

The following checks and maintenance should be performed at least once a year.

- Clean the flue side of the heat exchanger.
 - Clean the main burner.
 - Visually check the flue hood for deterioration or corrosion.
 - Check correct lighting and functioning.
 - Check correct calibration of the burner in domestic hot water (*when the boiler is connected to an external cylinder*) and central heating phases.
 - Check correct functioning of control and adjustment devices and in particular:
 - the intervention of main electrical switch positioned outside of the boiler;
 - system control thermostat intervention;
 - domestic hot water control thermostat intervention (*when the boiler is connected to an external cylinder*).
 - Check sealing efficiency of the gas circuit and the internal system.
 - Check the intervention of the device against no gas ionisation flame control. Intervention time must be less than 10 seconds.
 - Visually check for water leaks or oxidation from/on connections.
- Visually check that the water safety drain valve is not blocked.
 - Check that, after discharging system pressure and bringing it to zero (read on boiler manometer), the expansion vessel load is at 1.0 bar.
 - Check that the system static pressure (with system cold and after refilling the system by means of the filling valve) is between 1 and 1.2 bar.
 - Visually check that the safety and control devices have not been tampered with and/or shorted, in particular:
 - check the integrity of the storage tank's Magnesium Anode (*when the boiler is connected to an external storage tank unit*).
 - temperature safety thermostat;
 - water pressure switch,
 - flue exhaust control thermostat.
 - Check the condition and integrity of the electrical system and in particular:
 - electrical power cables must be inside the whipping;
 - there must be no traces of blackening or burning.

NOTE: in addition to yearly maintenance, you must also check the thermal system and thermal efficiency, with the frequency and procedures that comply with the technical regulations in force.

INSTALLATOR

USER

MAINTENANCE TECHNICIAN

3.18 VARIABLE HEAT OUTPUT.

		METHANE (G20)			BUTANE (G30)			PROPANE (G31)			
HEAT OUTPUT	HEAT OUTPUT	HEAT + DHW	BURNER GAS FLOW RATE	PRESS. NOZZLES PRESSURE		BURNER GAS FLOW RATE	PRESS. NOZZLES PRESSURE		BURNER GAS FLOW RATE	PRESS. NOZZLES PRESSURE	
(kW)	(kcal/h)		(m ³ /h)	(mbar)	(mm H ₂ O)	(kg/h)	(mbar)	(mm H ₂ O)	(kg/h)	(mbar)	(mm H ₂ O)
23.8	20468		2.77	14,00	142,8	2.07	27.70	282.5	2.03	35.70	364.0
23.0	19780		2.67	13,05	133,0	2.00	25.95	264.6	1.96	33.43	340.9
22.0	18920		2.56	11,92	121,5	1.91	23,86	243.3	1.88	30.74	313.4
21.6	18550		2.51	11,45	116,8	1.87	22.99	234.5	1.84	29.62	302.1
20.0	17200		2.33	9,86	100,5	1.74	20.00	204.0	1.71	25.76	262.7
19.0	16340		2.22	8,92	90,9	1.66	18.22	185.8	1.63	23.46	239.3
18.0	15480		2.11	8,03	81,9	1.57	16.54	168.7	1.55	21.29	217.1
17.0	14620		2.00	7,20	73,4	1.49	14.94	152.4	1.47	19.22	196.0
16.0	13760		1.89	6,42	65,5	1.41	13.43	137.0	1.38	17.27	176.1
15.0	12900		1.77	5,70	58,1	1.32	12.00	122.4	1.30	15.43	157.3
14.0	12040		1.66	5,02	51,2	1.24	10.65	108.6	1.22	13.68	139.5
13.0	11180		1.55	4,39	44,8	1.16	9.38	95.6	1.14	12.04	122.8
12.0	10320		1.44	3,81	38,8	1.08	8.18	83.4	1.06	10.50	107.0
11.0	9460		1.33	3,27	33,4	0.99	7.06	72.0	0.98	9.05	92.2
10.0	8600		1.22	2,78	28,4	0.91	6.01	61.3	0.89	7.69	78.4
9.5	8170		1.16	2,55	26,1	0.87	5.51	56.2	0.85	7.05	71.9
9.4	8084		1.15	2,51	25,6	0.86	5.41	55.2	0.85	6.92	70.6
7.0	6020	DHW	0.88	1,60	16,3	0.65	3.30	33.7	0.64	4.20	42.8

N.B.: Gas flow rates refer to heating power below a temperature of 15°C and at a pressure of 1013 mbar. Burner pressure values refer to use of gas at 15°C.

3.19 COMBUSTION PARAMETERS.

		G20	G30	G31
Gas nozzle diameter	mm	1.30	0.79	0.79
Supply pressure	mbar (mm H ₂ O)	20 (204)	29 (296)	37 (377)
Flue flow rate at nominal heat output	kg/h	73	75	74
Flue flow rate at min heat output	kg/h	61	57	58
CO ₂ at Q _n Nom./Min.	%	5,00 / 1,80	5,65 / 2,25	5,70 / 2,20
CO with 0% O ₂ at Q _n Nom./Min.	ppm	95 / 60	125 / 75	115 / 69
NO _x with 0% O ₂ at Q _n Nom./Min.	mg/kWh	245 / 125	362 / 152	338 / 176
Flue temperature at nominal output	°C	94	94	95
Flue temperature at minimum output	°C	77	85	84

Combustion parameters: measuring conditions of useful efficiency (flow temperature/return temperature= 80 / 60 °C), ambient temperature reference = 15°C.

3.20 TECHNICAL DATA.

Nominal heat input	kW (kcal/h)	26.2 (22492)
** DHW minimum heat input	kW (kcal/h)	8.3 (7116)
CH minimum heat input	kW (kcal/h)	10.9 (9357)
Nominal heat output (useful)	kW (kcal/h)	23.8 (20468)
** DHW minimum heat output (useful)	kW (kcal/h)	7.0 (6020)
CH minimum heat output (useful)	kW (kcal/h)	9.4 (8084)
* Efficiency at nominal heat output	%	91.0
* Efficiency at 30% nominal heat output load	%	89.3
Heat loss at case with burner On/Off	%	2.30 / 1.20
Heat loss at flue with burner On/Off	%	6.70 / 0.09
Central heating circuit max. operating pressure	bar	3
Central heating circuit max. operating temperature	°C	90
Adjustable central heating temperature	°C	35 - 85
System expansion vessel total volume	l	4.0
Expansion vessel factory-set pressure	bar	1
Water content in generator	l	2.5
Total head available with 1000 l/h flow rate	kPa (m H ₂ O)	24,52 (2,5)
Hot water production useful heat output	kW (kcal/h)	23.8 (20468)
** Domestic hot water adjustable temperature	°C	10 - 60
** Min. pressure (dynamic) domestic hot water circuit	bar	0.3
** Domestic hot water circuit max. working pressure	bar	10
** Minimum D.H.W. flow rate	l/min	1.5
Drawing capacity in continuous duty with UB Immergas (ΔT 30°C)	l/min	11,1
Weight of full boiler	kg	28.0
Weight of empty boiler	kg	25.5
Electrical connection	V/Hz	230/50
Power input	A	0.44
Installed electric power	W	95
Pump consumption	W	87
Equipment electrical system protection	-	IPX4D
Boiler flue circuit resistance	Pa	1.3
NO _x class	-	3
Weighted NO _x	mg/kWh	139
Weighted CO	mg/kWh	52
Type of appliance	B11BS	
Category	II2H3+	

- The data relevant to domestic hot water performance refer to a dynamic inlet pressure of 2 bar and an inlet temperature of 15°C; the values are measured directly at the boiler outlet considering that to obtain the data declared mixing with cold water is necessary.

- The max. sound level emitted during boiler operation is < 55dBA. The sound level value is referred to semianechoic chamber tests with boiler operating at max. heat output, with extension of flue gas exhaust system according to product standards.

- *Efficiencies refer to the lower heating value.
- ** When the boiler is connected to an external cylinder.

INSTALLATOR

USER

MAINTENANCE TECHNICIAN

3.21 DATA PLATE KEY.

Md		Cod. Md	
Sr N°	CHK	Cod. PIN	
Type			
Q _{nw} /Q _n min.	Q _{nw} /Q _n max.	P _n min.	P _n max.
PMS	PMW	D	TM
NO _x Class			

Note: the technical data are shown on the boiler data plate

	ENG
Md	Model
Cod. Md	Model code
Sr N°	Serial Number
CHK	Check
Cod. PIN	PIN code
Type	Type of installation (ref. CEN TR 1749)
Q _{nw} min.	Minimum heating capacity (domestic)
Q _n min.	Minimum heating capacity (heating)
Q _{nw} max.	Maximum heating capacity (domestic)
Q _n max.	Maximum heating capacity (heating)
P _n min.	Minimum heat output
P _n max.	Maximum heat output
PMS	Maximum pressure (system)
PMW	Maximum pressure (domestic)
D	Specific flow rate
TM	Maximum working temperature
NO _x Class	Nox Class

INSTALLATOR

USER

MAINTENANCE TECHNICIAN

INSTALLATOR

USER

MAINTENANCE TECHNICIAN

INSTALLATOR

USER

MAINTENANCE TECHNICIAN



This instruction booklet
is made of ecological paper



immergas.com

Immergas Europe S.r.o.
059051 Poprad - Matejovce - SK
Tel. +421.524314311
Fax +421.524314316



IMMERCAS
IMMERCAS SPA - ITALY
CERTIFIED COMPANY
UNI EN ISO 9001:2015

Design, manufacture and post-sale assistance of gas
boilers, gas water heaters and related accessories

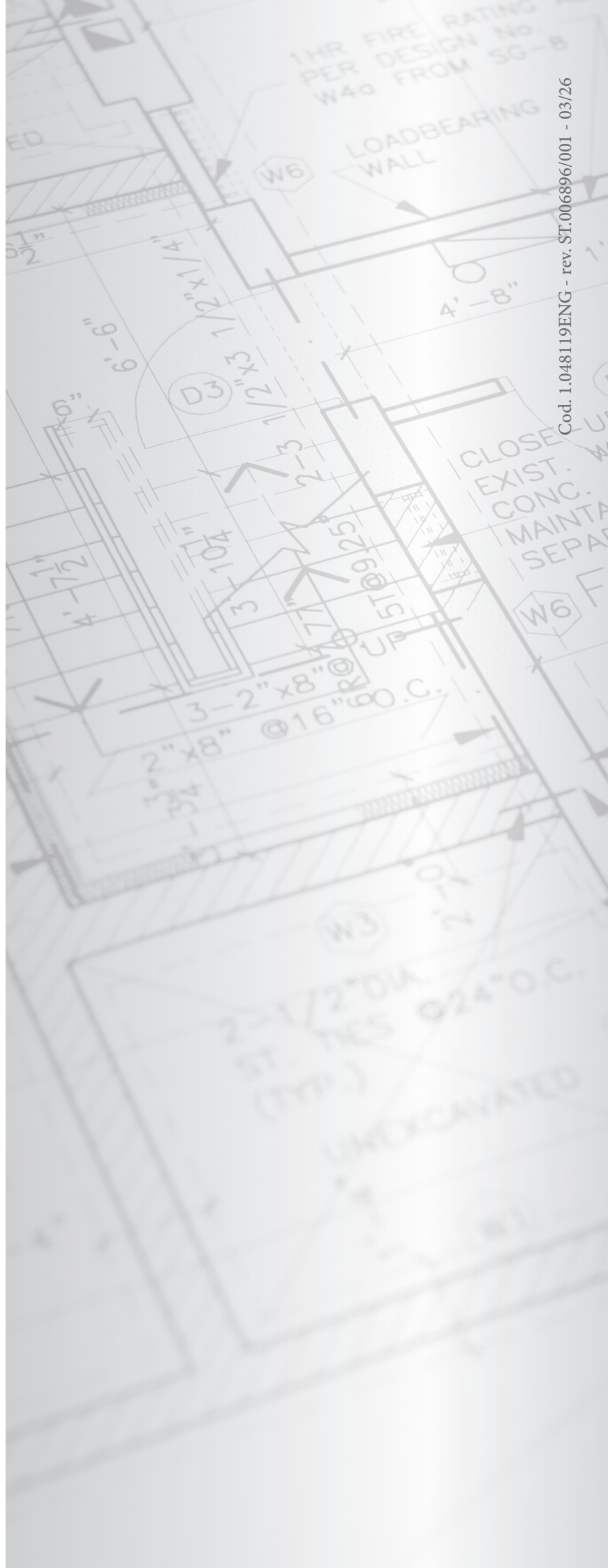

Cod. I.048119ENG - rev. ST.006896/001 - 03/26