

MA  
MAGIS  
USERS

Instructions and recommendations

IE

 **IMMERGAS**

**MAGIS**  
**M4-6-8 EH3**  
**M12-14-16 T EH9**

Block heat pumps with integrated  
backup heater  
Use and Installation

\*1.047741ENG\*



## INDEX

Dear Customer.....	4
List of abbreviations used.....	5
General Recommendations.....	6
Safety symbols used.....	7
Personal protective equipment.....	7
Introduction.....	8
<b>1 General safety warnings.....</b>	<b>10</b>
<b>2 General Introduction.....</b>	<b>13</b>
<b>3 Accessories.....</b>	<b>15</b>
3.1 Accessories supplied with the units 4-16 kw.....	15
<b>4 Prior to installation.....</b>	<b>16</b>
<b>5 Important information on the refrigerant.....</b>	<b>17</b>
<b>6 Installation site.....</b>	<b>18</b>
6.1 Selection of a cold weather location.....	20
6.2 Selection of a hot weather location.....	20
<b>7 Installation precautions.....</b>	<b>21</b>
7.1 Dimensions.....	21
7.2 Installation requirements.....	22
7.3 Position of drain hole.....	22
7.4 Clearance requirements for maintenance.....	23
7.5 Control Panel installation manual.....	25
<b>8 Typical application examples.....</b>	<b>30</b>
8.1 UNITS 4-16 KW: Application 1.....	30
8.2 UNITS 4-16 KW: Application 2.....	32
8.3 UNITS 4-16 KW: Cascade System.....	36
<b>9 Overview of the unit.....</b>	<b>38</b>
9.1 Disassembling the unit.....	38
9.2 Main components.....	39
9.3 Electronic control box.....	40
9.4 Water pipes.....	54
9.5 Filling with water.....	58
9.6 Water pipe insulation.....	58
9.7 Wiring on field.....	59
<b>10 Start up and configuration.....</b>	<b>81</b>
10.1 Overview of DIP switch settings.....	81
10.2 Initial start-up at low outdoor temperatures.....	82
10.3 Checks prior to operation.....	82
10.4 The circulation pump.....	83
10.5 On-field settings.....	84
<b>11 Test mode and final checks.....</b>	<b>106</b>
11.1 Final checks.....	106
11.2 Test operation (manual).....	106
<b>12 Maintenance and service.....</b>	<b>107</b>
<b>13 Troubleshooting.....</b>	<b>108</b>

13.1 General guidelines.....108  
13.2 General symptoms. ....108  
13.3 Operation parameters.....111  
13.4 Error codes. ....112

**14 Technical specifications. .... 120**  
14.1 General. .... 120  
14.2 Electrical technical specifications. .... 120

**15 Information on maintenance. .... 121**  
15.1 Attachments..... 124

## Dear Customer

*Congratulations for having chosen a top-quality Immergas product, able to assure well-being and safety for a long period of time. As an Immergas customer you can also count on a Qualified Authorised After-Sales Technical Assistance Centre, prepared and updated to guarantee constant efficiency of your appliance. Read the following pages carefully: you will be able to draw useful tips on the proper use of the device, compliance with which will confirm your satisfaction with the Immergas product.*

*For assistance and routine maintenance, contact Authorised Technical Service Centres: they have original spare parts and are specifically trained directly by the manufacturer.*

The company **IMMERGAS S.p.A.**, with registered office in via Cisa Ligure 95 42041 Brescello (RE), declares that the design, manufacturing and after-sales assistance processes comply with the requirements of standard **UNI EN ISO 9001:2015**.

For further details on the product CE marking, request a copy of the Declaration of Conformity from the manufacturer, specifying the appliance model and the language of the country.

The manufacturer declines all liability due to printing or transcription errors, reserving the right to make any modifications to its technical and commercial documents without forewarning.



## LIST OF ABBREVIATIONS USED

The following is the key of the abbreviations used in this document.

<i>ACS</i>	Domestic hot water
<i>CO<sub>2</sub></i>	Carbon dioxide
<i>CVC</i>	Fan coil
<i>DHW</i>	Domestic hot water
<i>etc.</i>	Etc.
<i>FCU</i>	Fan coil
<i>Fig.</i>	Figure
<i>FHL</i>	Floor heating circuit
<i>IBH</i>	Backup heater
<i>MFA</i>	Maximum fuse amp.
<i>MOP</i>	Maximum overcurrent protection
<i>Max.</i>	Maximum
<i>Min.</i>	Minimum
<i>Nom.</i>	Rated
<i>Par.</i>	Paragraph
<i>RAD</i>	Radiator
<i>Ta</i>	Room temperature
<i>TBH</i>	DHW storage tank backup heater



## GENERAL RECOMMENDATIONS

- The instruction booklet is an integral and essential part of the product and must be given to the new user in the case of transfer or succession of ownership.
  - It must be stored with care and consulted carefully, as all of the warnings provide important safety indications for installation, use and maintenance stages.
  - In compliance with the legislation in force, the systems must be designed by qualified professionals, within the dimensional limits established by the Law. Installation and maintenance must be performed in compliance with the regulations in force, according to the manufacturer's instructions and by professionally qualified staff, meaning staff with specific technical skills in the plant sector, as provided for by Law.
  - Improper installation or assembly of the Immergas device and/or components, accessories, kits and devices can cause unexpected problems for people, animals and objects. Read the instructions provided with the product carefully to ensure proper installation.
  - This instructions manual provides technical information for installing Immergas products. As for the other issues related to the installation of products (e.g. safety at the workplace, environmental protection, accident prevention), it is necessary to comply with the provisions of the standards in force and the principles of good practice.
  - All Immergas products are protected with suitable transport packaging.
  - The material must be stored in a dry place protected from the weather.
  - Maintenance must be carried out by skilled technical staff. For example, the Authorised Service Centre that represents a guarantee of qualifications and professionalism.
  - The appliance must only be destined for the use for which it has been expressly declared. Any other use will be considered improper and therefore potentially dangerous.
  - In the event of malfunctions, faults or incorrect operation, turn the appliance off and contact an authorised company (e.g. the Authorised Technical Assistance Centre, which has specifically trained staff and original spare parts). Do not attempt to modify or repair the appliance alone.
  - For further information regarding legislative and statutory provisions relative to the installation of heat pumps, consult the Immergas site at the following address: [www.immergas.com](http://www.immergas.com)
-

## SAFETY SYMBOLS USED



### GENERIC HAZARD

Strictly follow all of the indications next to the pictogram. Failure to follow the indications can generate hazard situations resulting in possible harm to the health of the operator and user in general, and/or property damage.



### ELECTRICAL HAZARD

Strictly follow all of the indications next to the pictogram. The symbol indicates the appliance's electrical components or, in this manual, identifies actions that can cause an electrical hazard.



### WARNING FOR INSTALLER

Read the instruction booklet carefully before installing the product.



### WARNINGS

Strictly follow all of the indications next to the pictogram. Failure to follow the indications can generate hazard situations resulting in possible minor injuries to the health of both the operator and the user in general, and/or slight material damage.



### ATTENTION

Read and understand the instructions of the appliance before carrying out any operation, carefully following the instructions given. Failure to observe the instructions may result in malfunction of the unit.



### COMBUSTIBLE MATERIAL WARNING

This symbol indicates that the appliance in question used a flammable refrigerant. There is a risk of fire if the refrigerant leaked or was exposed to an external ignition source.



### INFORMATION

Indicates useful tips or additional information.



### EARTH TERMINAL CONNECTION

The symbol identifies the appliance's earth terminal connection point.



### DISPOSAL WARNING

**The user must not dispose of the appliance at the end of its service life as municipal waste, but send it to appropriate collection centres.**

## PERSONAL PROTECTIVE EQUIPMENT



### SAFETY GLOVES



### EYE PROTECTION



### SAFETY FOOTWEAR

# INTRODUCTION

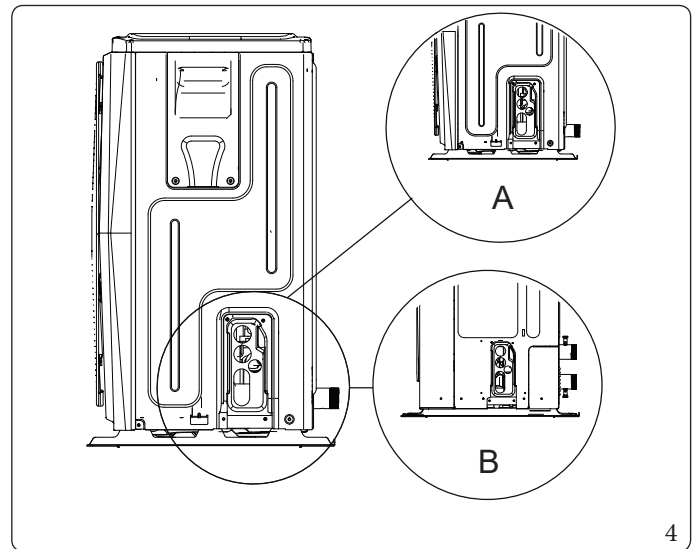
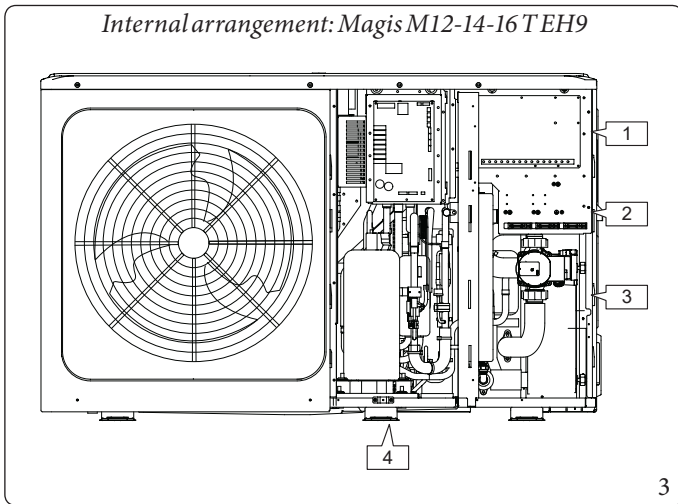
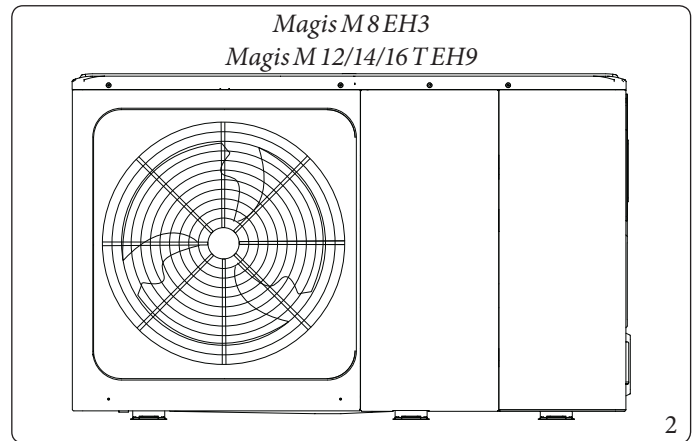
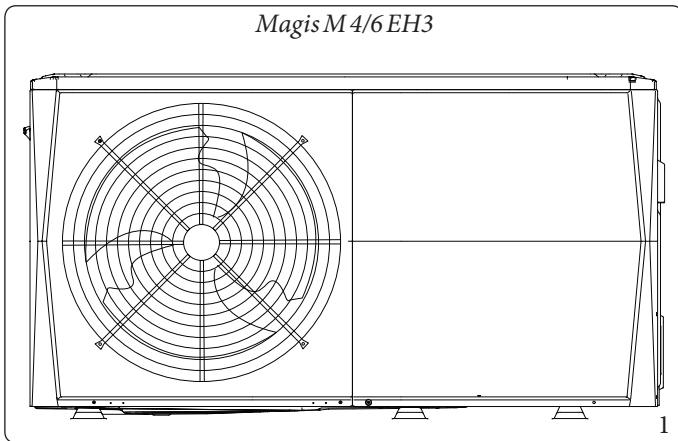

Key (Fig. 3):

- 1 - Electric control system
- 2 - Terminal board
- 3 - Hydraulic system
- 4 - Refrigerant system

Key (Fig. 4):

- A - Magis M4/6 EH3
- B - Magis M8 EH3  
Magis M12/14/16 TEH9

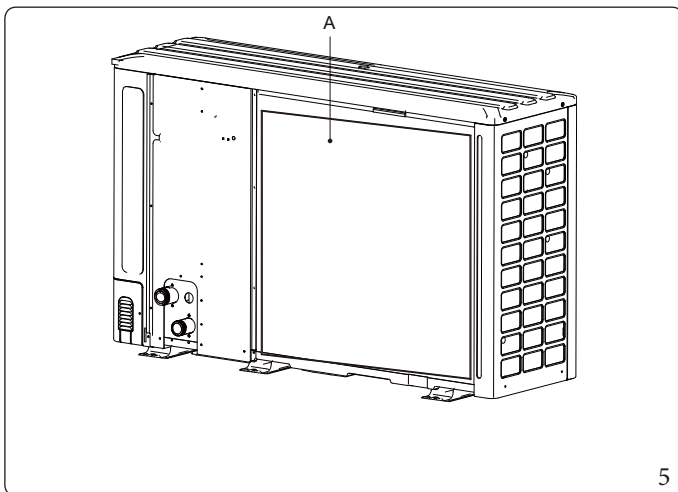

Key (Fig. 5):

- A - Please remove the protective panel after installation

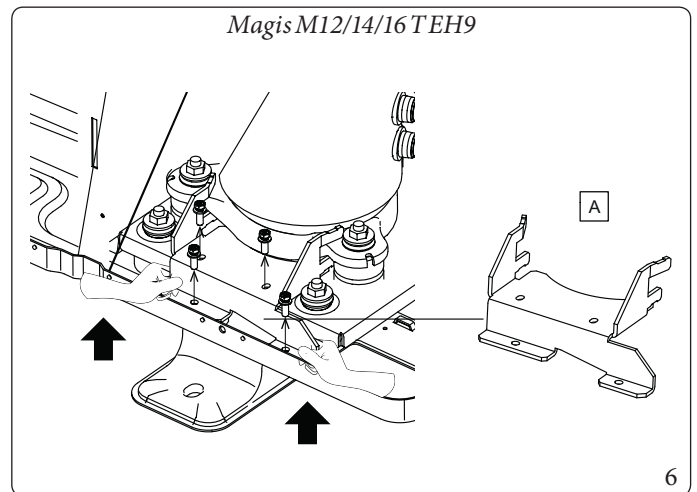

Key (Fig. 6):

- A - Eliminate the transport mount (Magis M12/14/16 TEH9)



The images in this manual are only used as a reference - refer to the actual product.

---



- The maximum length of the wiring that guarantees communication between the heat pump and the control panel is 50 m.
  - The power cables and communication wires are laid separately and cannot be placed in the same duct. Otherwise there would be electromagnetic interference. The power cables and wires for communication must not come into contact with the refrigerant pipe which at high temperatures could damage the wires.
  - The communication wires must be in shielded lines, including the line that goes from the heat pump to the control panel.
-

# 1 GENERAL SAFETY WARNINGS.

The precautions listed below are divided into the following types. They are rather important and therefore must be followed carefully. Meaning of DANGER, WARNING, CAUTION and NOTE symbols.



- Improper installation of the appliances or accessories can cause electric shocks, short-circuits, leaks, fire or other damage to the equipment. Make sure to only use accessories made by the supplier, which are specifically designed for the appliance and make sure that installation is performed by a skilled professional.
- All of the tasks described in this manual must be carried out by an authorised technician. During installation of the unit or when carrying out maintenance, make sure to wear adequate personal protective equipment, such as safety gloves and goggles.
- Contact your dealer for any type of service intervention.



**Maintenance must only be carried out according to the instructions given by the manufacturer of the appliance.**



**Maintenance and repairs that require the assistance of other qualified personnel must be carried out under the supervision of a person capable of using flammable refrigerants.**

## Explanation of the symbols displayed on the unit.

	WARNING	This symbol indicates that the appliance in question used a flammable refrigerant. There is a risk of fire if the refrigerant leaked or was exposed to an external ignition source.
	CAUTION	This symbol indicates to carefully read the user manual.
	CAUTION	This symbol indicates that service personnel must handle the appliance while referring to the installation manual
	CAUTION	This symbol indicates that service personnel must handle the appliance while referring to the installation manual
	CAUTION	This symbol indicates that there is information available such as instructions for use or installation instructions.



- Please switch off the power switch before touching the components of the electric terminals.
- When the service panels are removed, it is easy to mistakenly touch live components.
- Never touch the unit during installation or maintenance with the service panel removed.
- Do not touch the water pipes during and immediately after operation as they could be hot and burn your hands. To avoid injury, allow the pipes to return to normal temperature or put on protective gloves.
- Do not touch any switch with wet fingers. Touching a switch with wet fingers could cause electric shocks.
- Switch off the unit before touching electric components.



- **Tear up plastic packaging bags and throw them away so that children do not play with them. Children can risk dying by suffocation if they play with plastic bags.**
- **Safely dispose of packaging materials such as nails or other metal or wooden parts which could cause injury.**
- **Ask your dealer or qualified personnel to perform the installation jobs in compliance with this manual. Do not install the unit on your own. Improper installation could cause water leaks, electric shocks or fire.**
- **Make sure to use only the accessories and components specified for the installation jobs. Failure to use the specified components could cause water leaks, electric shocks, fire or cause the unit to fall off its stand.**
- **Install the unit on a foundation capable of bearing its weight. The appliance could fall or cause injury if not sufficiently stable.**
- **Perform the specified installation jobs taking into account strong winds, hurricanes or earthquakes. Improper installation could cause accidents due to the equipment falling.**
- **Make sure that all the electrical jobs are carried out by qualified personnel in compliance with local laws and regulations and with this manual, using a separate circuit. An insufficient capacity of the power circuit or an incorrect electrical system can cause electrical shocks and fire.**
- **Make sure to install an earth fault circuit switch in compliance with local laws and regulations. Failure to install an earth fault circuit switch can cause electrical shocks and fire.**
- **Check that all the cables are firm. Use the specified wires and check that the connections of the terminals or wires are protected against water and other outside adverse forces. An incomplete connection or fastening can cause a fire.**
- **When wiring the power supply, position the wires so that the front panel can be fixed safely. If the front panel is not in place, there could be overheating of terminals, electric shocks or fire.**
- **After having completed installation, make sure there are no refrigerant leaks.**
- **Never touch leaking refrigerant as it could cause frostbite. Do not touch the refrigerant pipes during and immediately after operation as the refrigerant inside could be hot or cold, depending on the conditions of the refrigerant flowing through the pipes, the compressor or the other parts of the refrigerant cycle. Touching the refrigerant pipes could cause burns or frostbite. To avoid injury, allow the pipes to return to normal temperature or, if you need to touch them, put on protective gloves.**
- **Do not touch the internal parts (pump, etc.) during and immediately after operation. Contact with internal parts can cause burns. To avoid injury, allow the internal components to return to normal temperature; otherwise, if you absolutely need to touch them, put on protective gloves.**



- Place the unit on the ground.
- The earthing resistance must comply with local laws and regulations.
- Do not connect the earth cable to gas or water pipelines, to lightning rods or the earth cables of the telephone.
- Incomplete earthing can cause electric shocks.
  - Gas pipes: gas leaks could cause a fire or explosion.
  - Water pipes: rigid rubber hoses do not guarantee earthing.
  - Lightning rods: or telephone earthing wires: the electrical threshold could increase anomalously if struck by lightning.
- Install the power cable at least 1 m away from TVs and radios to avoid interference or noise. (Depending on the radio waves, a distance of 1 m might not be enough to eliminate noise).
- Do not use pressurised water without a large diffuser. Do not use high-pressure cleaners for Cu/Cu and Cu/Al air coils. Concentrated and/or rotating water jets are strictly prohibited. Never use fluid with a temperature above 45°C to clean the air heat exchangers. The device must be installed in compliance with the national wiring regulations. If the power cable is damaged, it must be replaced by the manufacturer, by a service agent or by just as qualified persons to avoid danger.



- Do not install the unit in the following places:
  - Where there is mineral oil mist, oil spray or vapours. The plastic components could deteriorate and cause detachment or leakage of water.
  - Where corrosive gases are produced (such as sulphurous acid gas). Where the corrosion of copper pipes or welded parts can lead to refrigerant leaks.
  - Where there is machinery that emits electromagnetic waves. The electromagnetic waves can disturb the control system and cause the appliances to malfunction.
  - Where flammable gases could escape, where the carbon fibre or flammable dust is suspended in the air or where flammable volatile substances are handled such as paint thinners or petrol. These types of gas could cause a fire.
  - Where the air contains high levels of salt, like near the ocean.
  - Where there is high voltage isolation, like in factories.
  - In vehicles or ships.
  - Where there are acid vapours or alkalines.
- This appliance can be used by children at least 8 years old and by persons with reduced physical, sensory or mental capacities or with little experience and knowledge as long as they are supervised or receive instructions on how to use the appliance safely and understand its risks. Children should not play with the appliance. Cleaning and maintenance of the utility must not be carried out by children without supervision.
- Make sure that children do not use the product as a toy.
- If the power cable is damaged, it must be replaced by the manufacturer, by a service agent or by just as qualified persons.
- **DISPOSAL:** Do not dispose of this product as unsorted city waste. This waste must be collected separately for special treatment. Do not dispose of electrical equipment as city waste; make use of separate collection facilities. Contact your local government for information on available collection facilities. If the electrical equipment is disposed of in landfills, the hazardous substances can infiltrate into groundwater and enter the food chain, thus damaging your health and well-being.
- Check the safety of the area and installation (walls, floors, etc.) without concealed dangers such as water, electricity and gas.
- Before installation, check whether the power supply of the utility meets the electrical installation requirements of the unit (including reliable earthing, dispersion and the diameter of the electrical load cable, etc.). If the electrical installation requirements of the product are not met, the product cannot be installed until this is rectified.
- When several units are installed in a centralised manner, please confirm balancing of the three-phase power load and do not allow multiple units to be assembled in the same three-phase power supply phase.
- The installed product must be firmly fastened. Use reinforcement measures where necessary.
- To guarantee the safety of the product, please restart the unit at least once every 3 months so that it can perform a self-inspection.



- Information on fluorinated gases:
    - This unit contains fluorinated gases. For specific information on the type and amount of gas, see the relative label on the unit. National standards on gas must be complied with.
    - Installation, service, maintenance and repair operations on this unit must be carried out by a certified technician.
    - The product must be uninstalled and recycled by a certified technician.
    - If the system is fitted with a leak detection system, it must be checked at least every 12 months. When a leak check is carried out on the unit, you are warmly recommended to correctly log all the controls.
-



## 2 GENERAL INTRODUCTION.

- Magis M4-6-8 EH3 and Magis M12-14-16 EH9 block heat pumps are used both for heating and cooling applications and for domestic hot water tanks. They can be coupled with fan coils, floor heating applications, low-temperature high-efficiency radiators, domestic hot water tanks and solar kits.
- The unit is supplied with a control panel.
- The unit's built-in backup heater can increase the heating capacity in case of cold external temperatures. The backup heater also serves as a backup in the event of a malfunction and as protection against freezing for the external water pipes during winter.



- The maximum length of the wiring that guarantees communication between the heat pump and the control panel is 50 m.
- The power cables and communication wires are laid separately and cannot be placed in the same duct. Otherwise there would be electromagnetic interference. The power cables and wires for communication must not come into contact with the refrigerant pipe which at high temperatures could damage the wires.
- The communication wires must be in shielded lines, including the line that goes from the heat pump to the control panel.

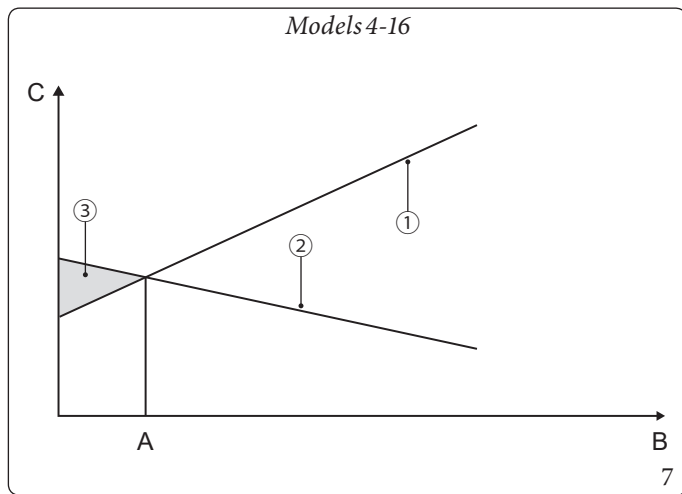

Key (Fig. 7):

- 1 - Heat pump capacity.
  - 2 - Required heating capacity (depending on site).
  - 3 - Additional heating capacity supplied by a backup heater.
- A - Tbivalent
  - B - External temperature
  - C - Capacity/load

### Domestic hot water tank (optional)

A domestic hot water storage tank can be connected to the unit (with or without tank booster heater (TBH)).

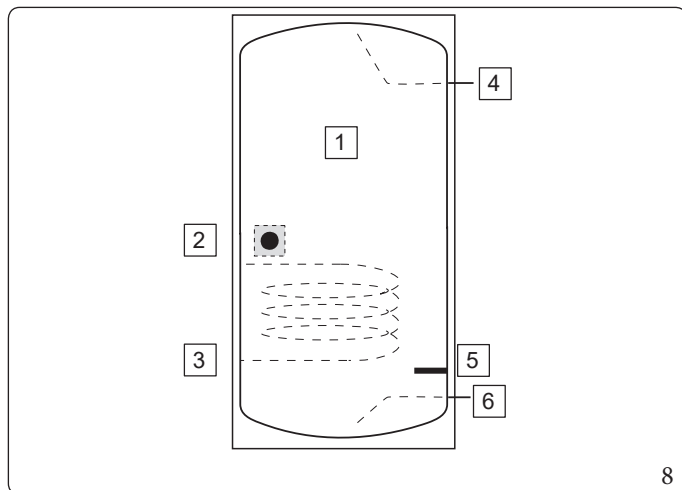

Key (Fig. 8):

- 1 - Tank
- 2 - Temperature probe (T5)
- 3 - Coil
- 4 - Outlet
- 5 - Tank booster heater (TBH)
- 6 - Inlet

The DHW tank booster heater (TBH) must be installed below the temperature probe (T5).

The DHW storage tank coil must be installed below the temperature probe.

### Room thermostat (optional)

The room thermostat can be connected to the unit (the room thermostat must be far away from the heating source when the installation place is chosen).

### Solar control unit (optional)

A solar control unit can be connected to the unit for the production of domestic hot water with thermal solar system, with relative coil inside the storage tank.

The unit has a freezing prevention function using the heat pump or the backup heater to keep the water system safe from freezing in all conditions. Since a power failure could occur while the unit is unattended, it is recommended to empty the system (if there is no glycol in the water) (see paragraph "Anti-freeze protection of water circuit." in chapter 9.4).

### Unit operating ranges 4-16kW.

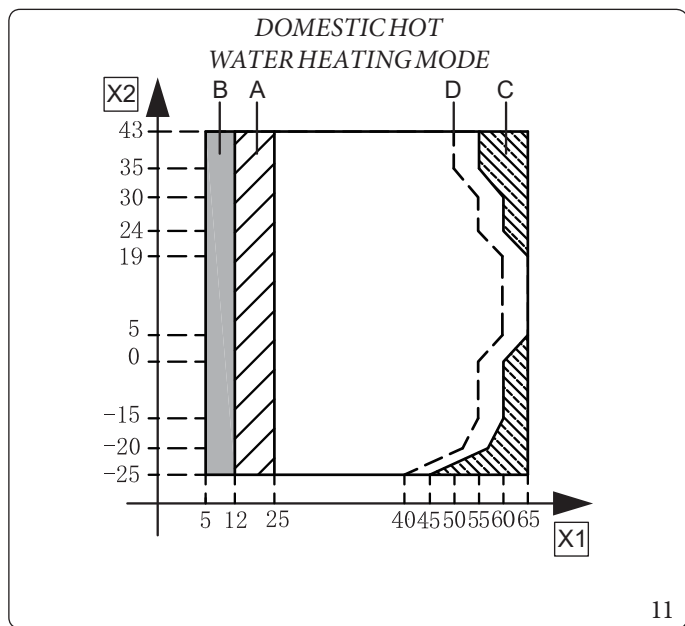
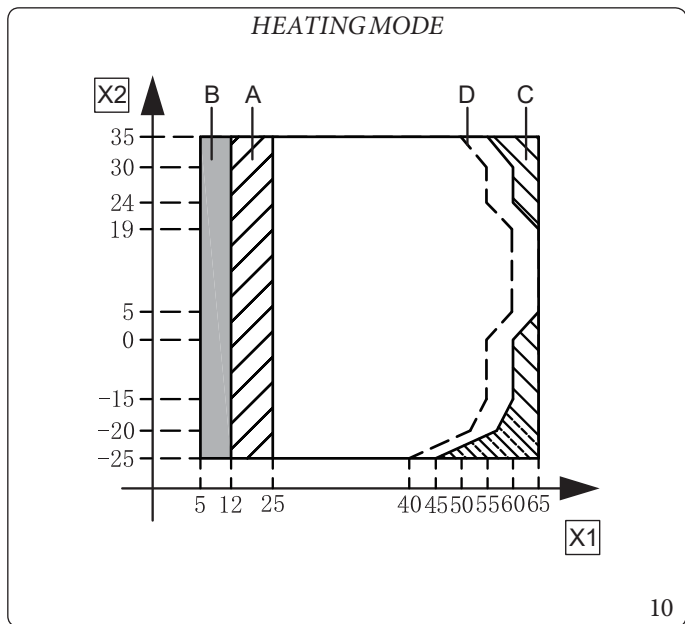
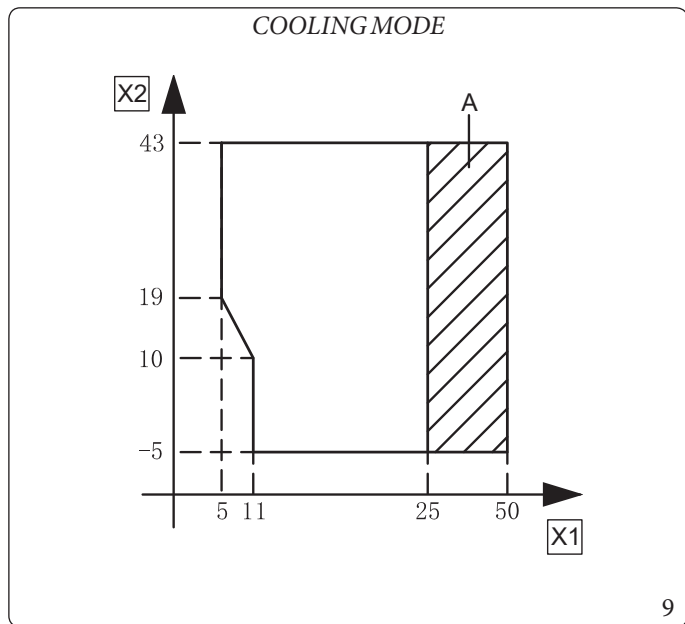

Key (Fig. 9 - 10 - 11):

- X1 - Water flow temperature (°C)
- X2 - External temperature (°C)
- A - Operating range by means of heat pumps with possible restriction and protection.
- B - If the IBH setting is active, only IBH switches on. If the IBH setting is not active, only the heat pump switches on; there could be cases of restriction and protection while the heat pump is running.
- C - The heat pump switches off, only IBH switches on (if present).
- D - Maximum inlet water temperature.













In DHW mode, the maximum DHW storage tank temperature, which the heat pump can reach without using the TBH or IBH electric resistance, at different external temperatures (T4), is listed below:







External temperature T4 (°C)	-25÷-21	-20÷-15	-14÷-11	-10÷-5	-4÷-1	0÷4	5÷9	10÷14	15÷19	20÷24	25÷29	30÷34	35÷39	40÷43
Maximum DHW storage tank temperature (°C)	35	40	45	48	52	55	56	57	56	55	52	50	48	45

 The maximum storage tank temperature of 60°C can only be reached with the use of the TBH or IBH electric resistance.

### 3 ACCESSORIES.

#### 3.1 ACCESSORIES SUPPLIED WITH THE UNITS 4-16 KW.

Accessories supplied with the units					
Name	Shape	Quantity	Name	Shape	Quantity
Use and maintenance manual		1	Temperature probe for domestic hot water (T5) or zone 2 (Tw2) or thermostat controlled storage tank (Tbt1)		1
Control Panel manual		1	Drain pipe		1
Technical data manual		1	Energy label		1
Y-filter		1	Customer wiring clamps		2
					3
Control panel		1	Network adapter**		1
SG (SMART GRID) link		1	50 kΩ resistance for remote DHW demand		1

Accessories available from the supplier					
Name	Shape	Quantity	Name	Shape	Quantity
Inertial storage tank temperature probe (Tbt1)*		1	Extension cable for Tw2		1
Extension cable for Tbt1		1	Solar temperature probe (Tsolar)		1
Zone 2 flow temperature probe (Tw2)		1	Extension cable for Tsolar		1

Probes and 10 m long extensions for Tbt1, Tw2, Tsolar can be shared; if these functions are necessary simultaneously, also order these probes and the extension cable.

\* = If the system is installed in parallel, Tbt1 must be connected and installed in the inertial storage tank.

\*\* = When the units are connected in parallel, for example when communication between the units is unstable (like a Hd failure code), add a corresponding network cable between ports H1 and H2 to the terminal of the communication system.

The sensors Tbt1, T5 and the extension cable can be shared; the sensors Tw2, Tsolar and the extension wire can be shared. If these functions are needed at the same time, customise these sensors plus the extension.

# 4 PRIOR TO INSTALLATION.

## Prior to installation.

Make sure to confirm the model name and serial number of the unit.

## Handling.

Due to the relatively large size and heavy weight of the unit, it must only be handled with lifting equipment with harnessing. The harnesses can be fitted in the sleeves on the base frame, specifically made for this purpose.



- To avoid injuries, do not touch the air inlet or the aluminium fins of the unit.
- Do not use the grips of the fan grilles so as not to damage them.
- The unit is very heavy! Do not allow it to fall due to an incorrect inclination during handling.

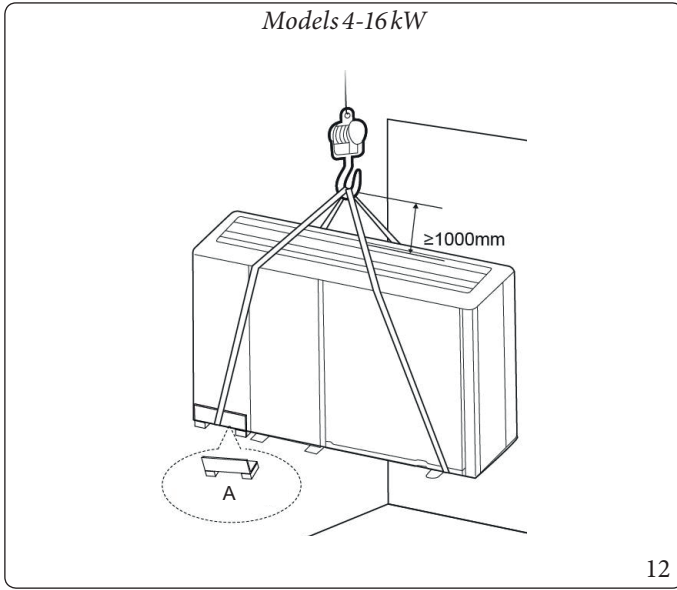

Key (Fig. 12):

A - Angular

The hook and the centre of gravity of the unit must be on a vertical line to avoid an improper inclination.

Have the lifting cord pass as represented in the image (Fig. Models 4-16kW12).

## Position of the centre of gravity of the units 4-6kW and 8-16kW.

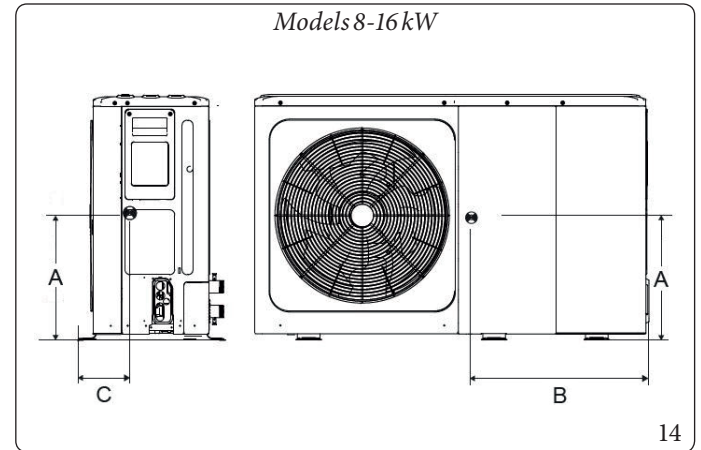
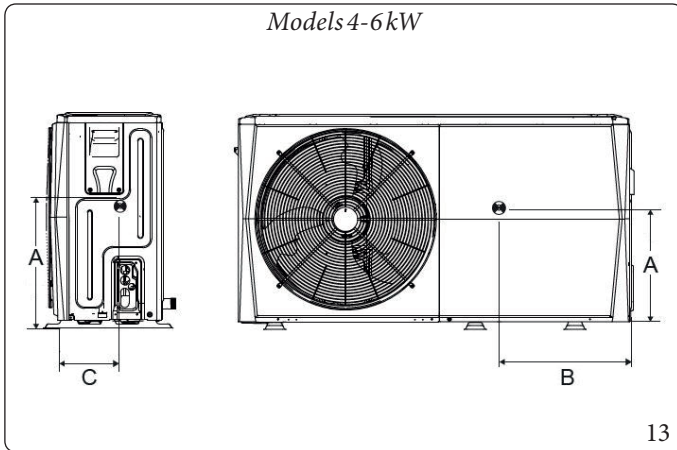

Model	A	B	C
Single phase 4-6kW	295 mm	540 mm	190 mm
Single phase 8kW	330 mm	580 mm	280 mm
Three-phase 12-14-16kW	200 mm	605 mm	245 mm

## 5 IMPORTANT INFORMATION ON THE REFRIGERANT.

This product contains fluorinated gas whose release into the air is prohibited.

Type of refrigerant: R32; Volume of GWP: 675.

GWP = Global Warning Potential

Model	Volume of refrigerant loaded in the unit at the factory	
	Refrigerant (kg)	Tonnes of CO2 equivalent
4kW	1,40	0,95
6kW	1,40	0,95
8kW	1,40	0,95
12kW	1,75	1,18
14kW	1,75	1,18
16kW	1,75	1,18



- This unit is a hermetically sealed appliance that contains fluorinated greenhouse gas.
- Installation, operation and maintenance can only be carried out by certified persons.

## 6 INSTALLATION SITE.



- **The unit is supplied with flammable refrigerant and must be installed in a properly ventilated place. If the appliance is installed indoors, an additional refrigerant detection device must be added in addition to a further ventilation appliance pursuant to standard EN378. Make sure to take adequate measures so that the unit is not used to house small animals.**
- **Animals that come into contact with electric components could cause operating failures, smoke or fire. Please advise the customer to keep the area around the unit clean.**

- Choose an installation site where the following conditions are met and which is approved by the customer.
  - Well ventilated places.
  - Places where the unit does not bother neighbours.
  - Safe places that can bear the weight and vibrations of the unit and where it can be installed on a flat surface.
  - Places where flammable gas or flammable product leaks are not possible.
  - The appliance is not intended to be used in potentially explosive atmospheres.
  - Places where clearance for maintenance can be guaranteed.
  - Places where the pipes and lengths of the wiring of the units are within the admissible limits.
  - Places where the water escaping the appliance cannot damage the environment (e.g. in case of blocked drain pipe).
  - Places where rain can be prevented as far as possible.
  - Do not install the unit in places which are often used as workspace. In case of construction work (for example grinding, etc.) which creates lots of dust, the appliance must be covered.
  - Do not place any object or equipment above the unit (top plate).
  - Do not climb, sit or stand on the unit.
  - Make sure that sufficient precautions are taken in case of refrigerant leaks according to local laws and regulations on the matter.
  - Do not install the unit near the sea or in the presence of corrosive gas.
- When the unit is installed in a place exposed to strong wind, pay particular attention to the following.
 

Strong winds 5 m/sec or more that blow against the air outlet of the unit cause a short circuit (suction of exhaust air) which could have the following consequences.

  - Deterioration of operating capacity.
  - Frequent acceleration of icing in heating mode.
  - Interruption of operation due to the high pressure increase.
  - When a strong wind continuously blows on the front of the unit, the fan can begin to spin so quickly that it breaks.

Under normal conditions, refer to the following figures for installation of the units 4-16 kW:

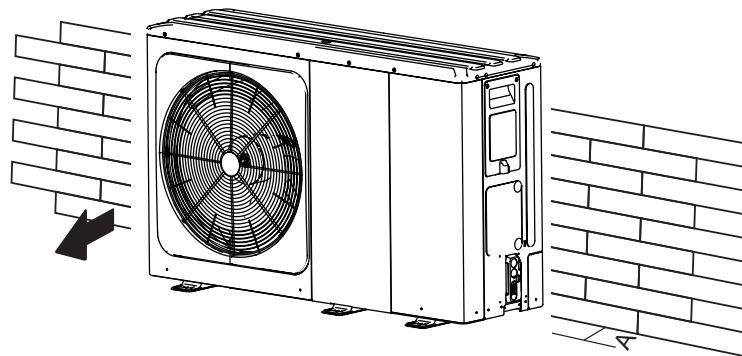

15

Unit	A
4-6 kW	≥ 300 mm
8-16 kW	≥ 300 mm

If there is strong wind and its direction can be foreseen, refer to the figures below for installation of the unit (any of them will do). Turn the outlet side of the air towards the wall of the building, fence or screen.

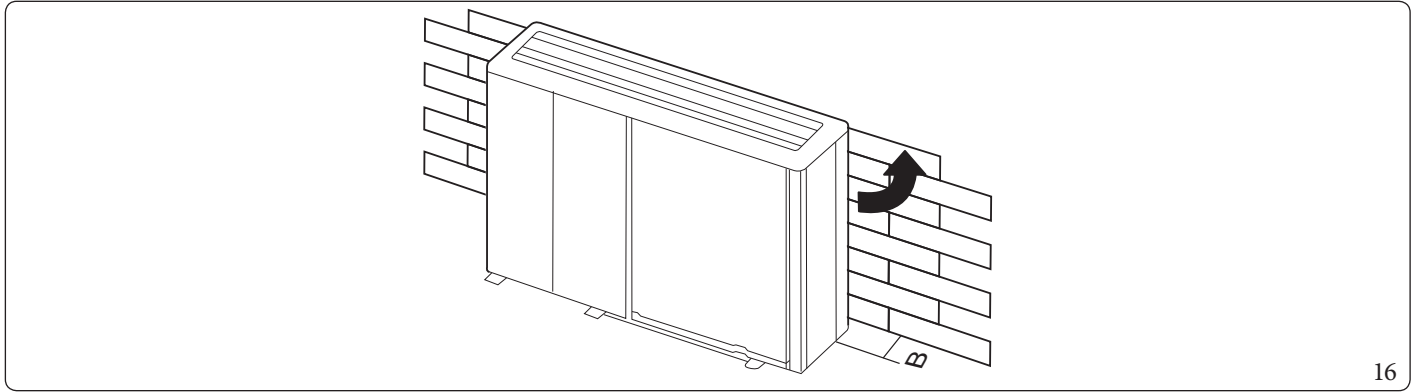

Unit	A
4-6kW	≥ 1000 mm
8-16kW	≥ 1500 mm

Make sure there is sufficient space for installation. Arrange the outlet side at a right angle with respect to the wind direction.

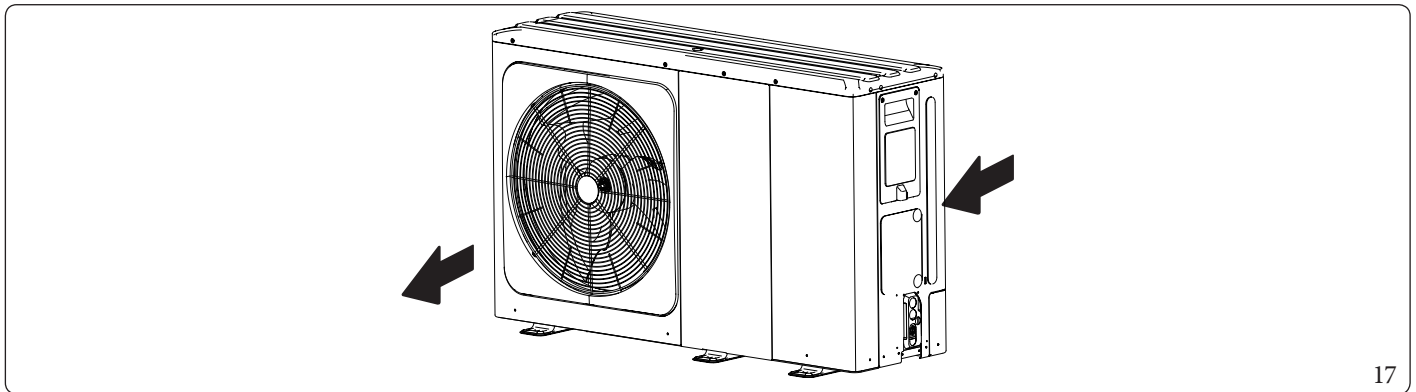

- Prepare a water discharge channel around the foundation, to drain the water around the unit.
- If the water has difficulty flowing out of the unit, mount the unit on a cement block foundation, etc. (approximately 100 mm (3.93 in) high).
- If the unit is installed on a frame, assemble a waterproof plate (about 100 mm) on the lower side of the unit to prevent the water from entering from below.
- When the unit is installed in a place frequently exposed to snow, please pay particular attention to raise the foundation as high as possible.
- If the unit is installed on a building structure, please install a waterproof tray (about 100 mm on the bottom side of the unit) so that the drain water does not flow out (see Fig. 18).

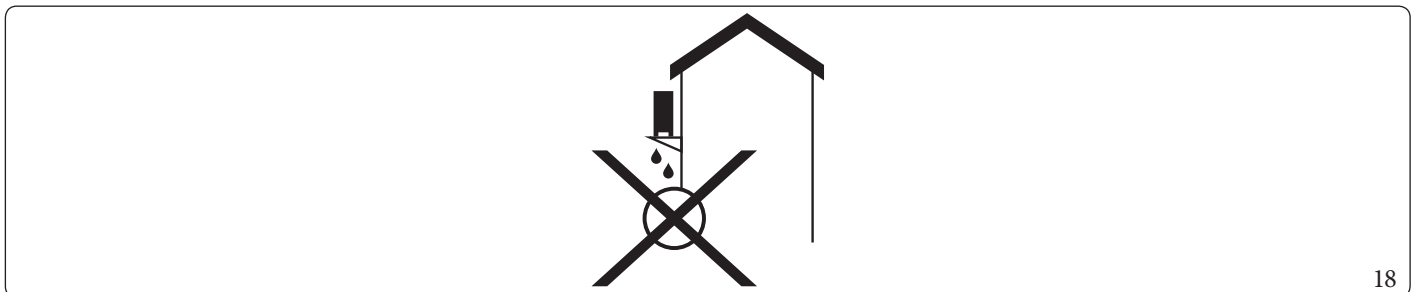

## 6.1 SELECTION OF A COLD WEATHER LOCATION.

See Chap. 4, paragraph "Handling."



When the unit is used in cold climates, make sure to follow the instructions below.

- To avoid exposure to wind, install the unit with the intake side facing the wall.
- Never install the unit in a place where the intake side can be directly exposed to the wind.
- To avoid exposure to the wind, install a deflector on the air exhaust side of the unit.
- In areas with abundant snowfalls, it is very important to choose an installation site where the snow does not affect the appliance. If a side blowing snowfall can occur, make sure that the finned coil of the heat exchanger is not affected by the snow (build a roof when necessary).

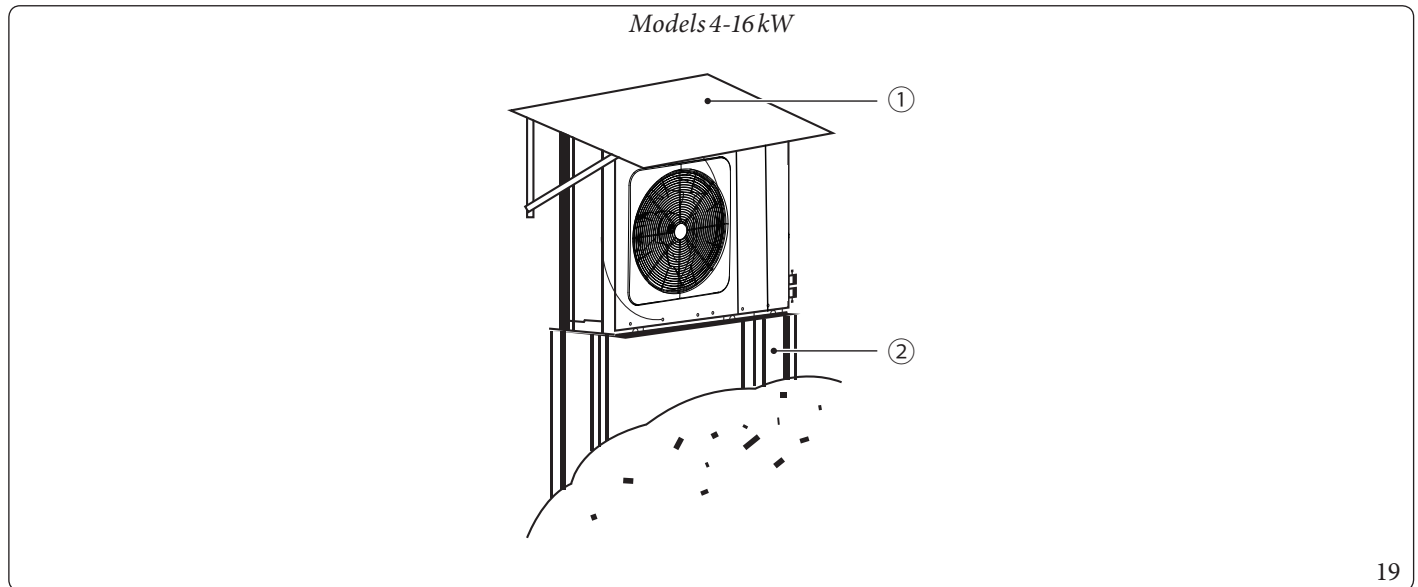

Key (Fig. 19):

- 1 - Build a large roof.
- 2 - Build a pedestal.

Install the unit high enough so that it cannot be buried in the snow.

## 6.2 SELECTION OF A HOT WEATHER LOCATION.

Since the outside temperature is measured by the air thermistor of the heat pump, make sure to install the unit in the shade or to build a roof so that it is not exposed to direct sunlight and is not affected by the heat of the sun. Otherwise the unit will need to be protected.



# 7 INSTALLATION PRECAUTIONS.

## 7.1 DIMENSIONS.

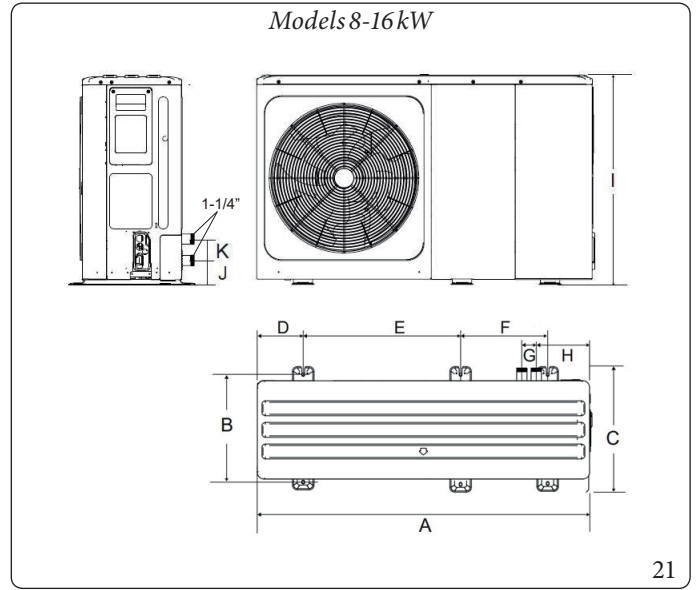
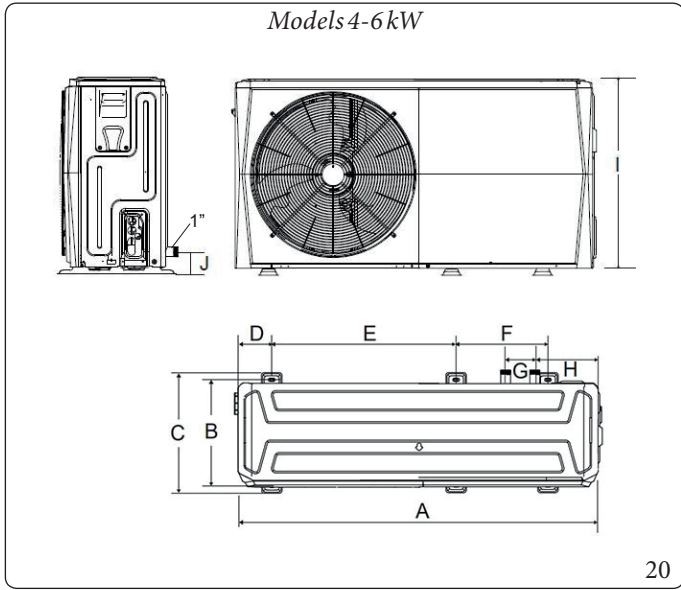

Model	A	B	C	D	E	F	G	H	I	J	K
4-6kW	1295 mm	375 mm	426 mm	120 mm	640 mm	380 mm	105 mm	225 mm	718 mm	81 mm	/
8-16kW	1385 mm	460 mm	523 mm	192 mm	656 mm	363 mm	60 mm	221 mm	865 mm	102 mm	81 mm

## 7.2 INSTALLATION REQUIREMENTS.

- Check the strength and level of the ground where the unit is installed so that it does not vibrate or make noise during operation.
- Securely fasten the appliance with the foundation bolts, following the foundation drawing shown in the figure (prepare six Ø10 expansion bolts, nuts and washers easily found in the market).
- Screw the anchor bolts up to 20 mm from the surface of the foundation.

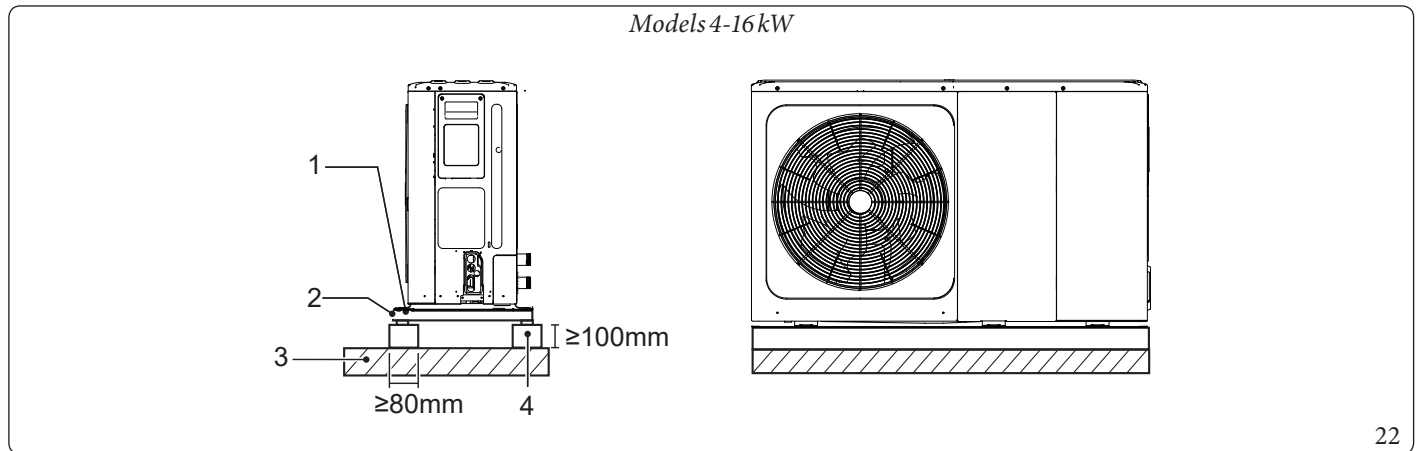

Key (Fig. 22):

- 1 - Ø10 Expansion bolt
- 2 - Anti-shock rubber mat

- 3 - Solid surface or cover
- 4 - Concrete base  $h \geq 100\text{mm}$

## 7.3 POSITION OF DRAIN HOLE.

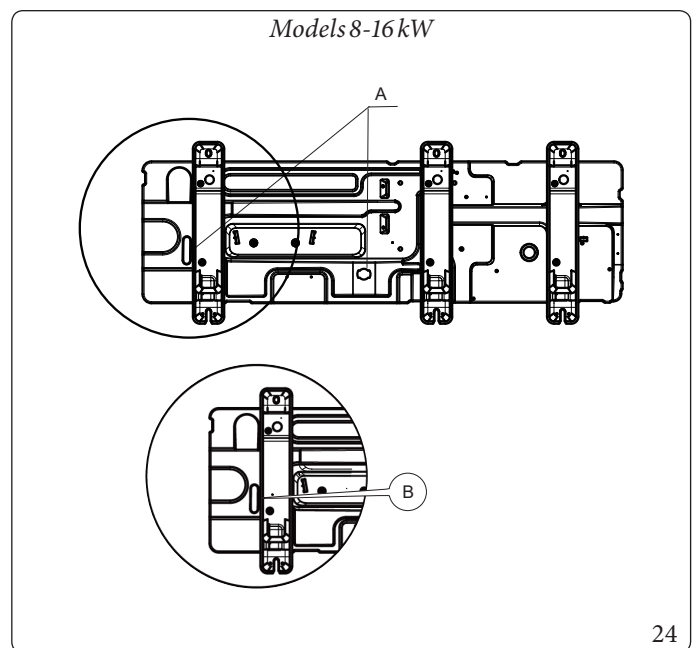
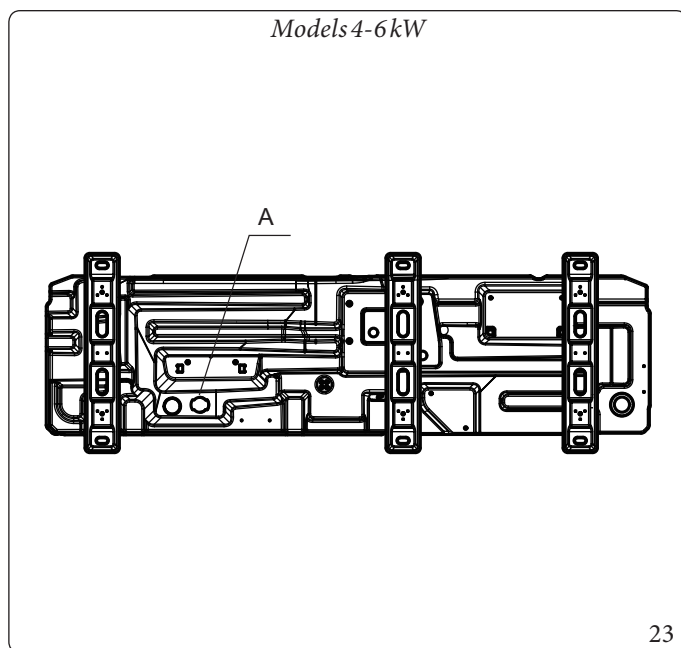

Key (Fig. 23- 24):

- A - Drain hole
- B - This drain hole is plugged by a rubber cap. If the small drain hole does that meet the drainage requirements, the large drain hole can be used at the same time.

Make sure that the condensate water is properly evacuated. If necessary, use a drain tank (supply) to prevent the drain water from escaping.



An electric heating cable must be installed if the water is not able to flow out due to the cold (Only for models 4-16 kW: even if the large drain hole is unplugged).

## 7.4 CLEARANCE REQUIREMENTS FOR MAINTENANCE.

### Models 4-16kW.

#### - In case of stacked installation.

1. If there are obstacles obstructing the outlet side.

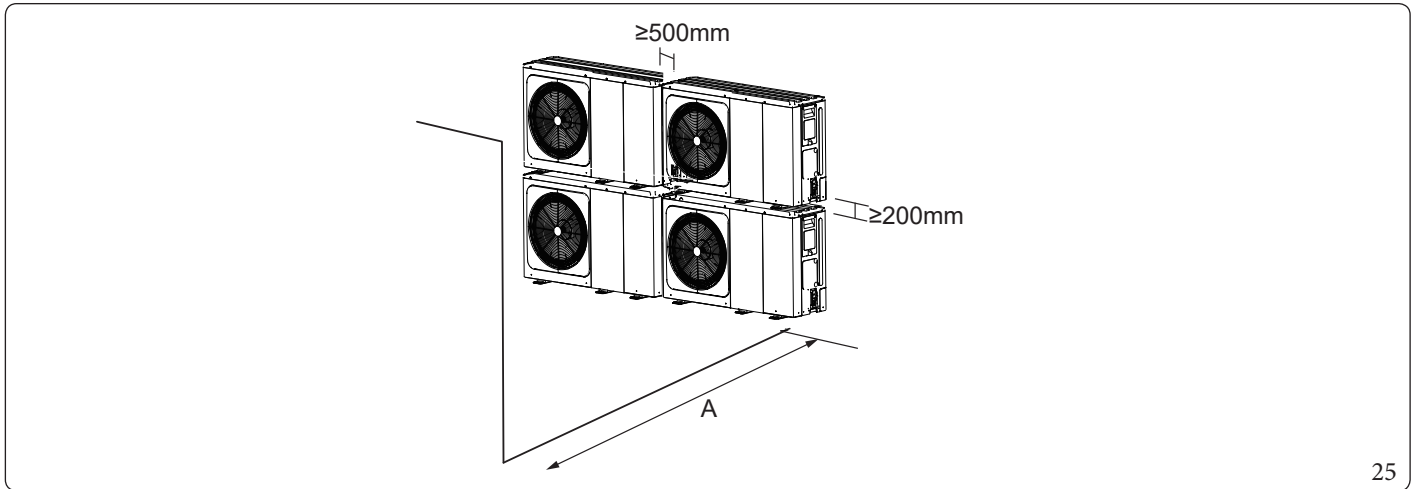

25

Unit	A
4-6kW	$\geq 300\text{mm}$
8-16kW	$\geq 300\text{mm}$

2. If there are obstacles obstructing the air inlet.

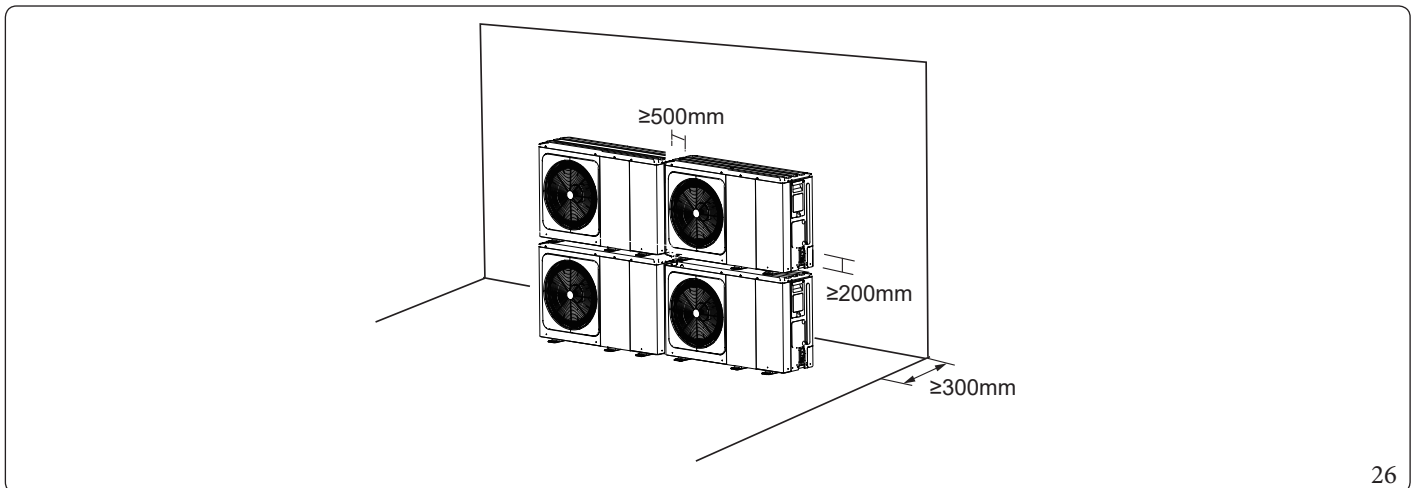

26

- For assembly in several rows (on roofs, etc.).  
 In case of installation of several units in rows side-by-side.

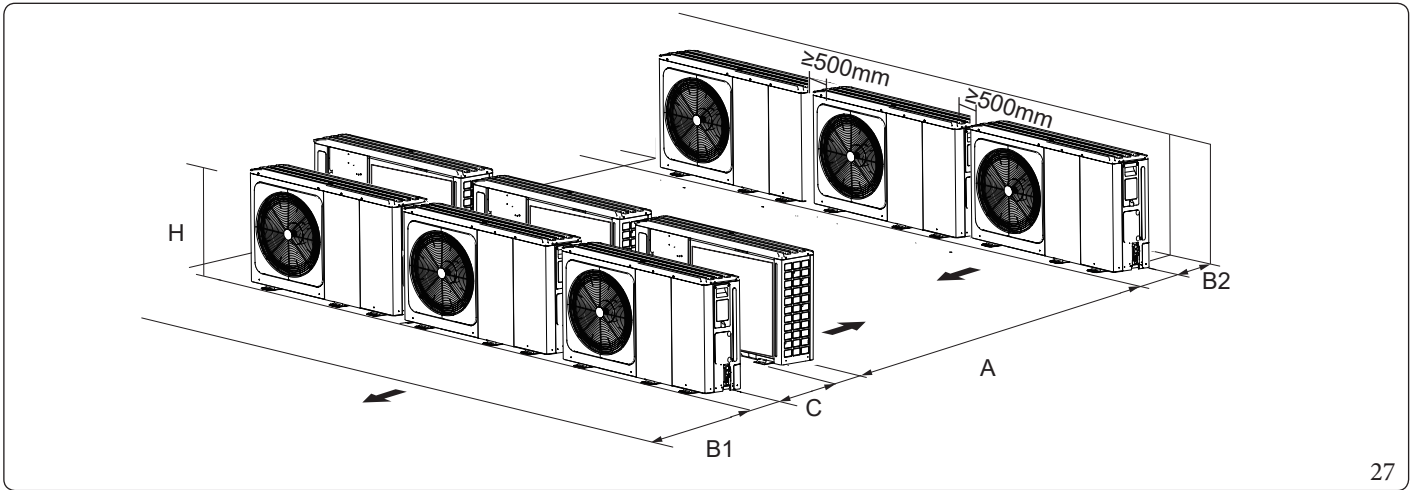

27

Unit	A	B1	B2	C
4-6kW	≥ 2500 mm	≥ 1000 mm	≥ 300 mm	≥ 600 mm
8-16kW	≥ 3000 mm	≥ 1500 mm		

## 7.5 CONTROL PANEL INSTALLATION MANUAL.

### Safety precautions.

- Read the safety precautions carefully before installing the unit.
- It is recommended to strictly abide by the important safety tips given below.
- Make sure that nothing anomalous occurs during execution of the test and completion of installation, then deliver the manual to the user.
- Meaning of symbols:



Indicates that improper use could cause death or serious injury.



Indicates that improper use could cause irreparable damage to the appliance or personal injury.



- **Have the unit installed by qualified technicians. Unqualified personnel might perform a non-professional installation, with the risk of electric shocks or fire.**
- **Strictly follow the instructions in this manual. Incorrect installation could cause electric shocks or fire.**
- **Re-installation must be carried out by qualified technicians. Incorrect installation could cause electric shocks or fire.**
- **Do not take it upon yourself to disassemble the unit. Incorrect disassembly could cause malfunctioning or overheating with the resulting risk of fire.**



- Do not install the unit in a place where flammable gas leaks could occur. A flammable gas leak near the control panel could burst into a fire.
- Wiring must be adequate to the current intensity of the control panel. Otherwise an electric dispersion could occur with consequent risk of fire.
- Use the cables indicated in the wiring diagram. Do not apply any external force to the terminal. Otherwise the wires could break, heat up and cause a fire.

### Other precautions.

#### • Place of installation.

Do not install the unit in places where there are large amounts of oil, vapour, sulphurous gases. Otherwise the appliance could deform and become unusable.

#### • Preparation prior to installation.

1. Check that the following components are all present:

No.	Name	Qty	Notes
1	Control panel	1	-
2	Self-tapping round Philips head screw	3	For wall-mounting
3	Round Philips head screw	2	For mounting on electric switchgear
4	Use and installation manual	1	-
5	Plastic spacer	2	This accessory is used to install the control panel inside the electric cabinet
6	Plastic plug	3	For wall-mounting

• **Notes for installation of the control panel.**

1. This installation manual contains information on how to install the control panel.
2. The control panel is a low-voltage circuit. Never connect it to a normal 220V/380V circuit, or insert it in the same conduit as the circuit wiring.
3. The screened cable must be stably earthed or problems could occur regarding transmission of the signal.
4. Do not try to extend the screened cable by cutting it. Use the connection clamp if necessary.
5. After having performed the connection, do not use a Megger Tester to check isolation of the signal cable.

**Control panel installation and setting procedure.**

• **Dimensions.**

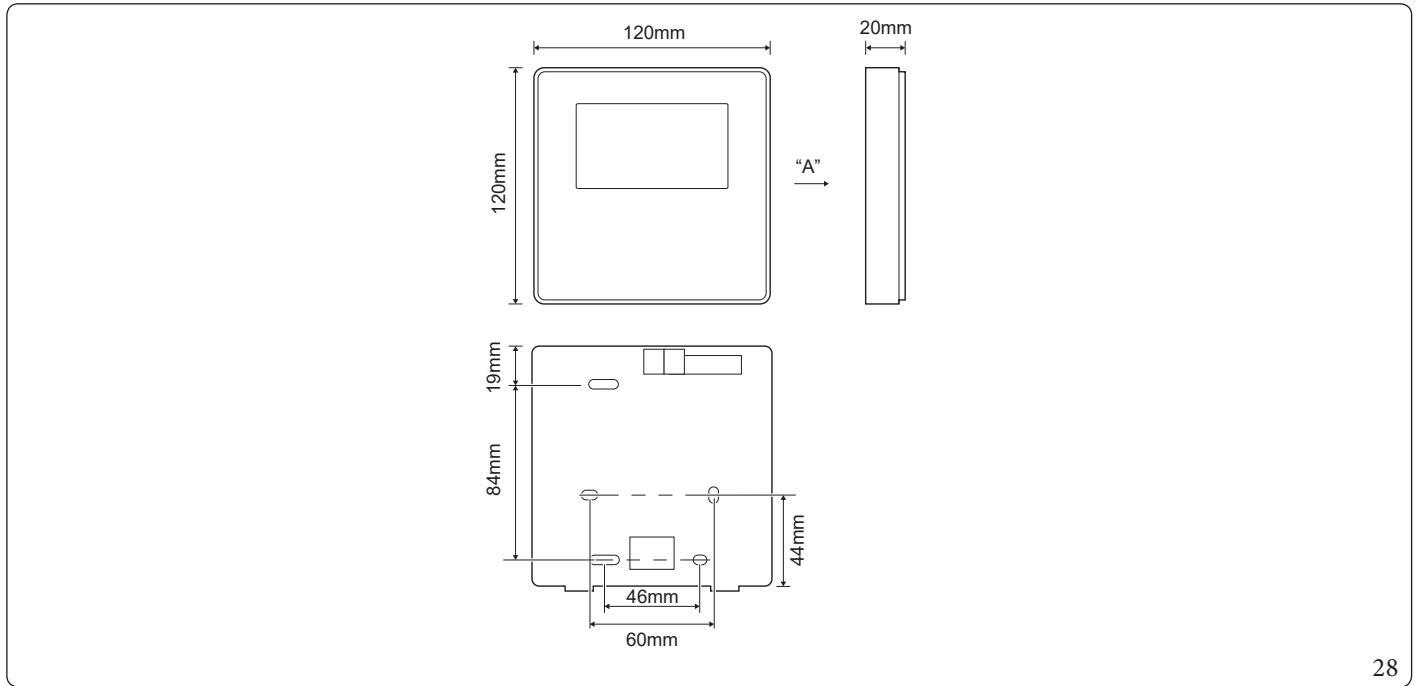

28

• **Wiring.**

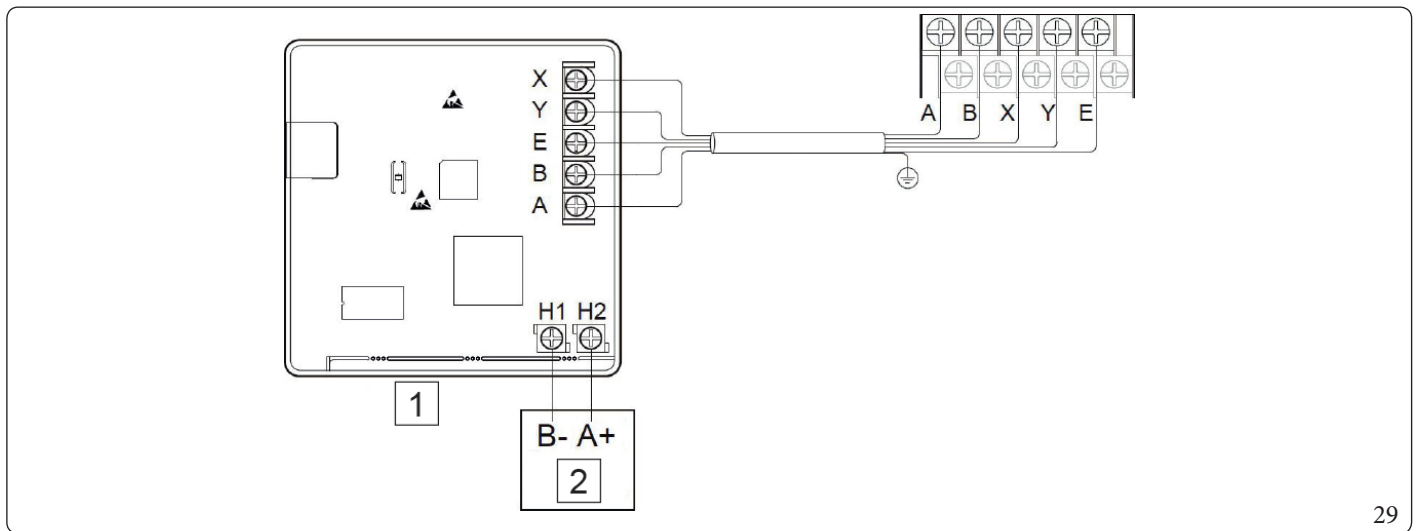

29

Key (Fig. 29):

- 1 - Control panel
- 2 - Modbus

Input voltage (A/B)	13.5 V AC
Wiring dimensions	0.75 mm <sup>2</sup>

• **Installation of rear cover.**

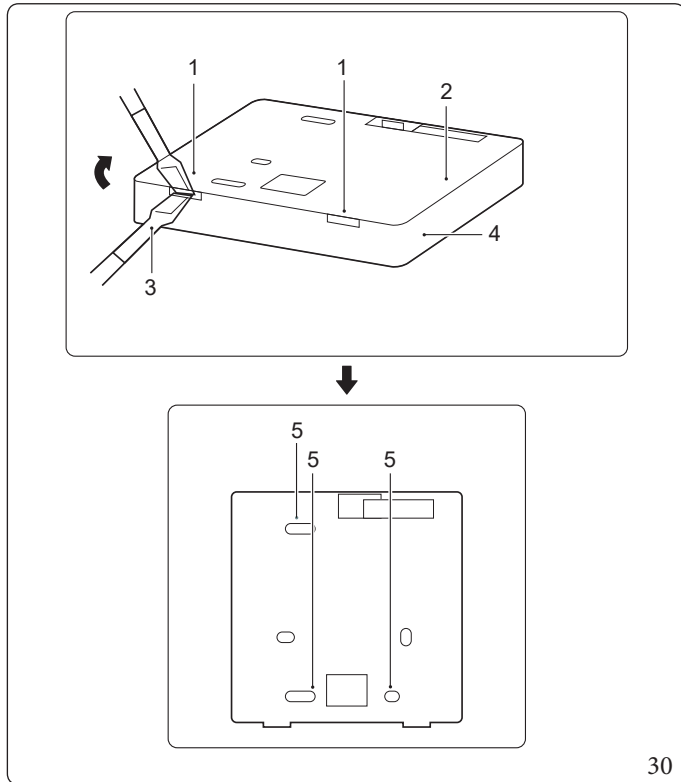

30

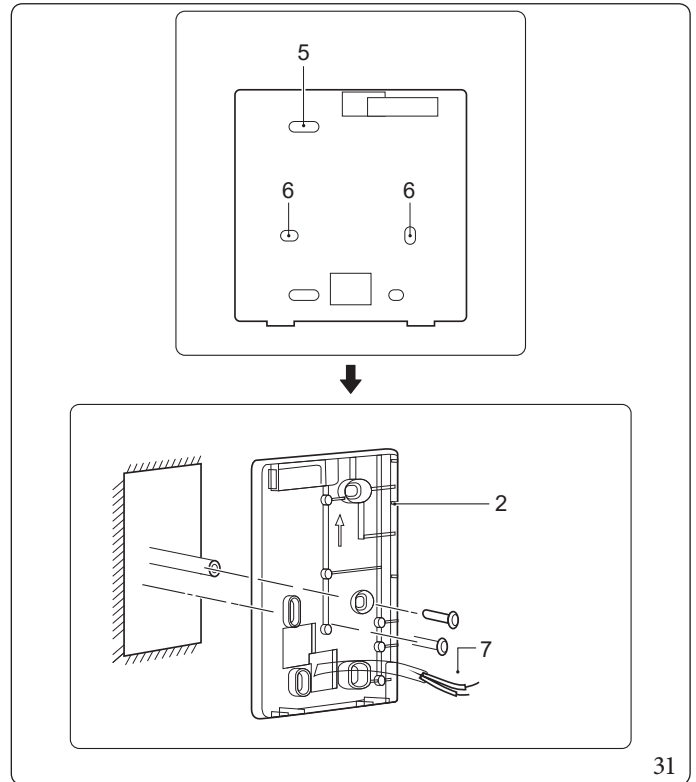

31

Key (Fig. 30 - 31):

- 1 - Closing position
- 2 - Rear cover
- 3 - Flat-headed screwdriver
- 4 - Front cover

- 5 - Screw hole for three M4X20
- 6 - Screw hole on junction box 86, use two M4X25mm
- 7 - Wires

1. Insert a flat-headed screwdriver at the closing point at the bottom of the control panel and rotate the screwdriver to remove the rear cover (be careful not to damage it).
2. Use three M4X20 screws to directly mount the rear cover on the wall.
3. Use two M4X25 screws to install the rear cover on the junction box 86 and use a M4X20 screw to fix it to the wall.
4. When inserting the screw plug in the wall, make sure it is flush with the wall.
5. Use the Phillips screws to fix the bottom cover of the control panel into the wall using the screw plug. Make sure that the bottom cover of the control panel is at the same height after installation, then reposition the control panel on the bottom cover.
6. Do not overtighten the screw to prevent it from deforming the rear cover.

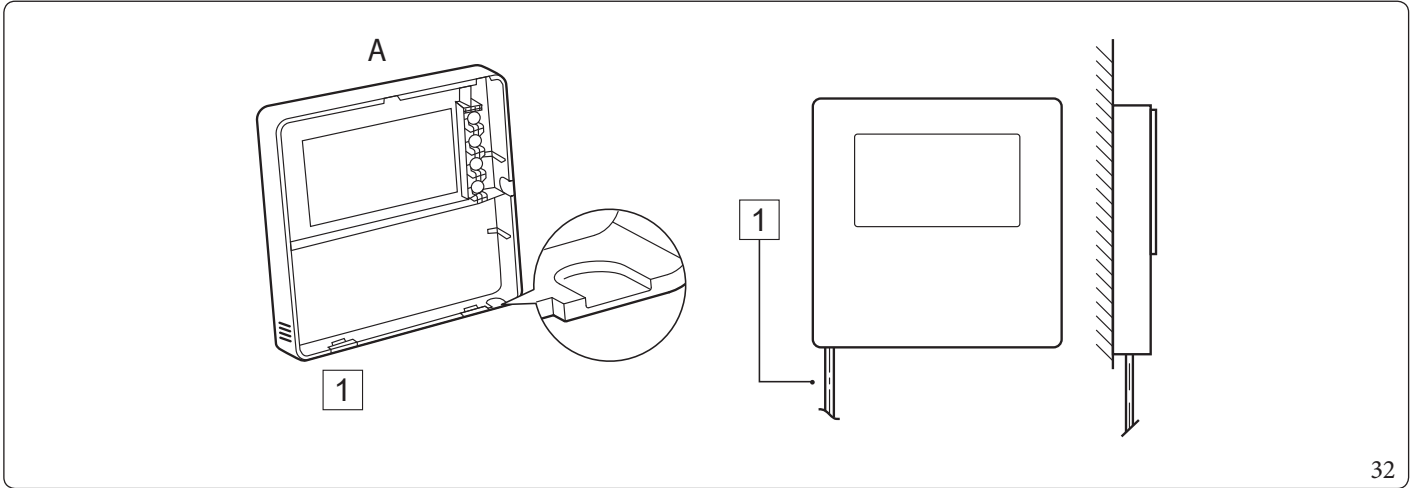

32

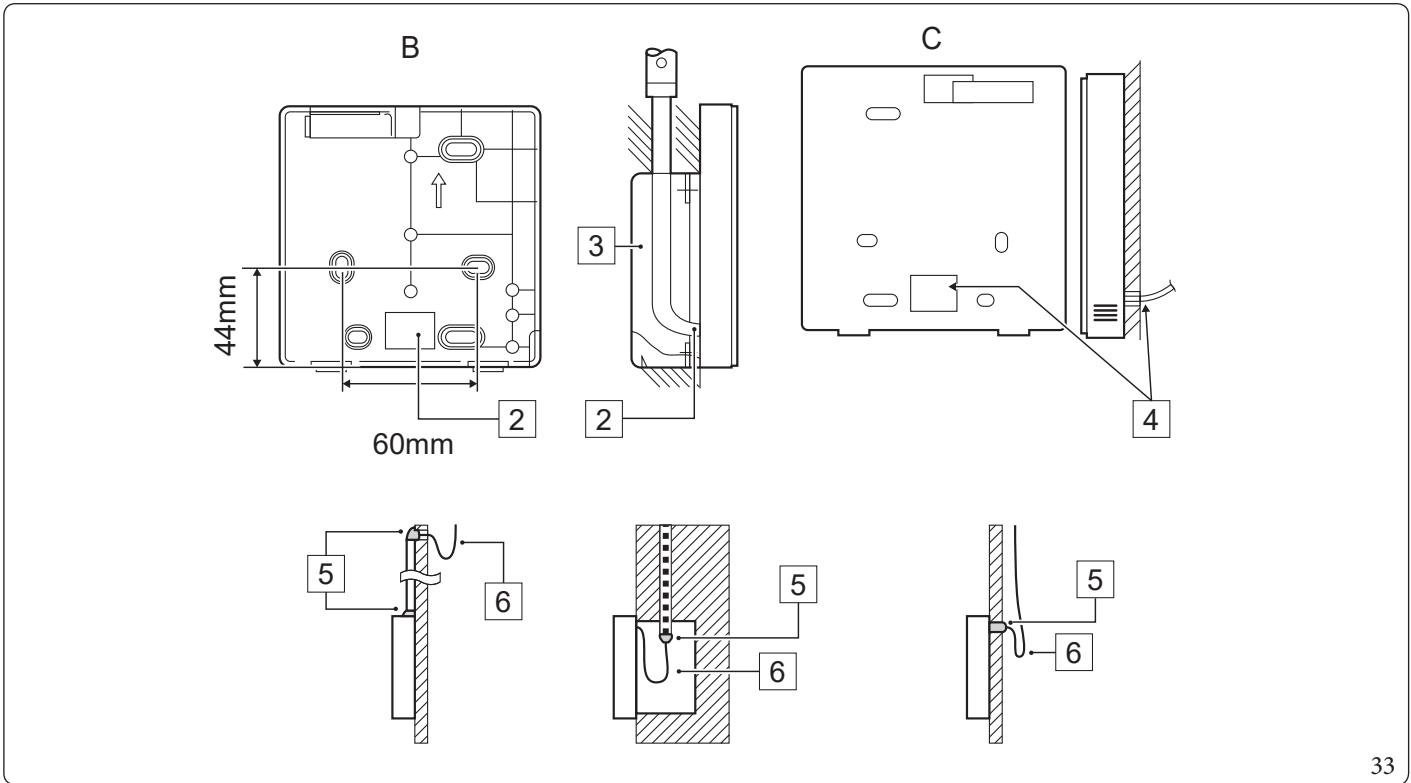

33

Key (Fig. 32-33):

- 1 - Lower left side wires outlet hole slit
- 2 - Wiring hole
- 3 - Junction box
- 4 - Wall hole and wiring hole. Diameter: Ø8-Ø10
- 5 - Stucco
- 6 - Folded cable

To prevent water from penetrating into the control panel, use anchoring and stucco to seal the passage holes when installing the wires.



**Installation of front cover.**

After having positioned the front cover, close it without blocking the wire during installation.

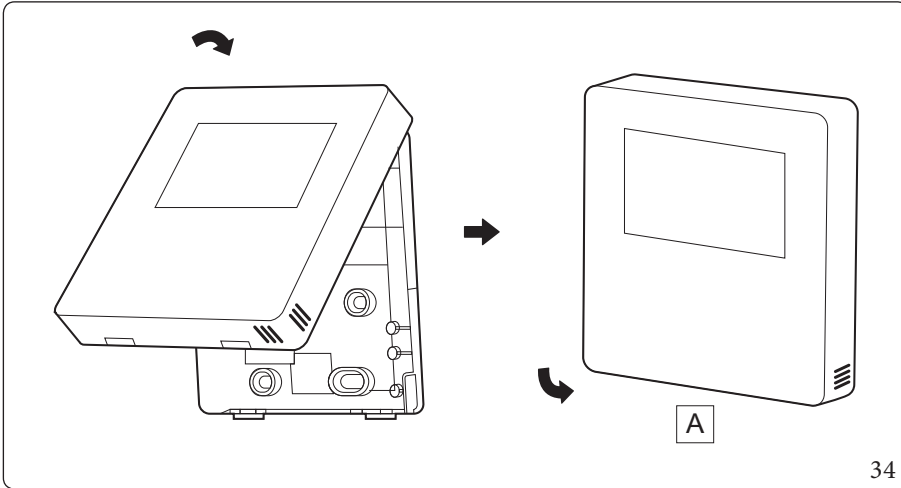

Key (Fig. 34):

A - The sensor must be sheltered from humidity

Install the rear cover correctly and firmly close the front and rear covers; otherwise the front cover will fall off.

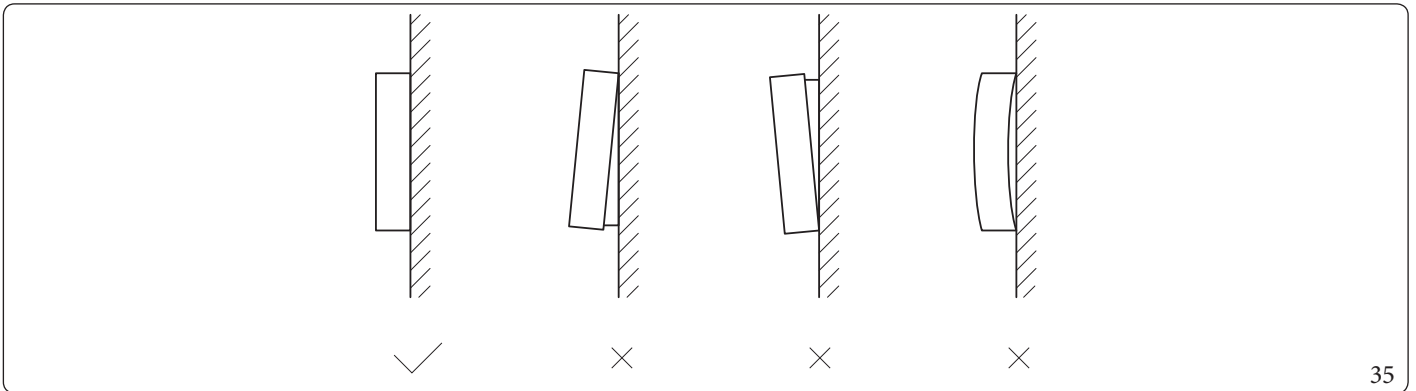

# 8 TYPICAL APPLICATION EXAMPLES.

The following application examples are for illustrative purposes only for units 4-16 kW.

## 8.1 UNITS 4-16 KW: APPLICATION 1.

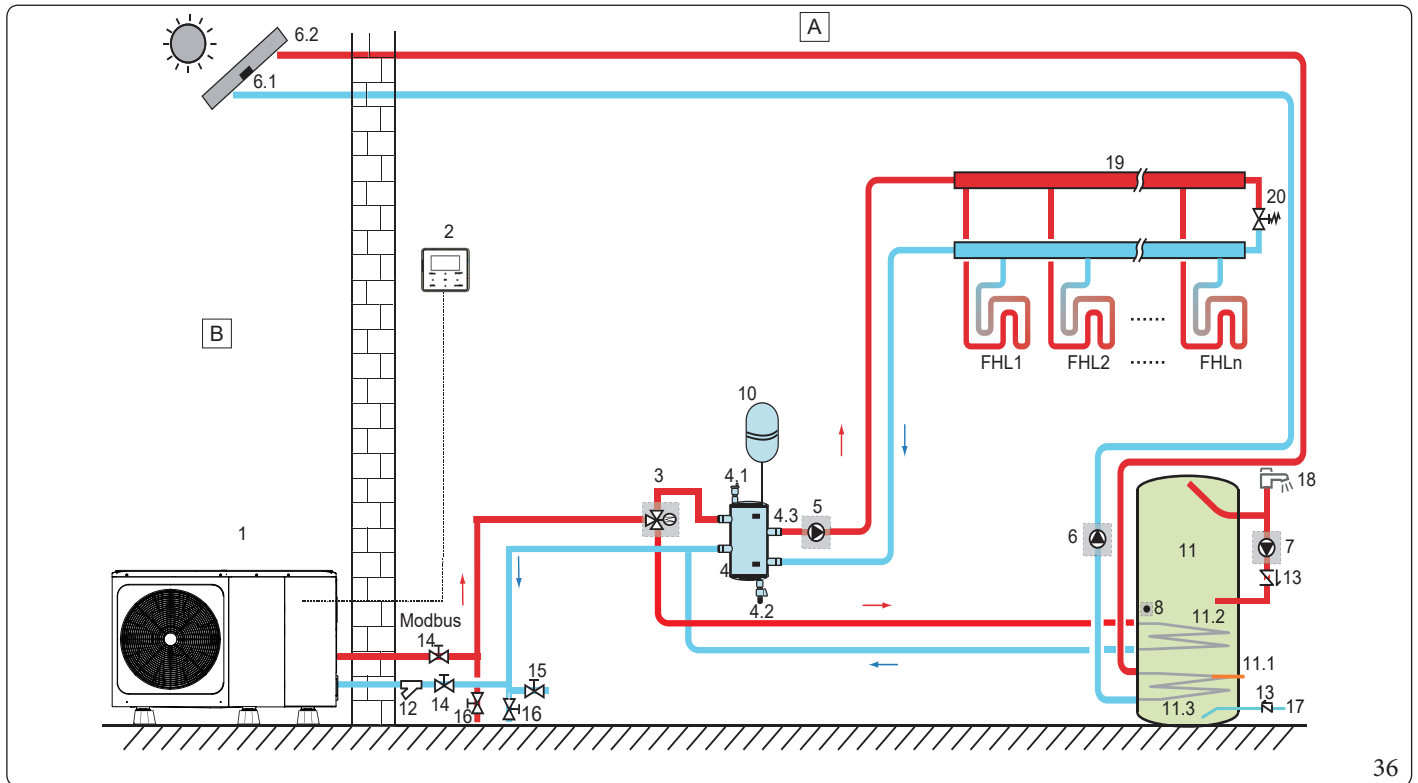

36

Pos.	Assembly unit	Pos.	Assembly unit
1	Main unit	11.1	TBH: Domestic hot water storage tank backup heater
2	Control panel	11.2	Coil 1, of DHW storage tank
3	Sv1: 3-way valve	11.3	Coil 2, of DHW storage tank for thermal solar system
4	Inertial storage tank	12	Filter (accessory)
4.1	Automatic air purge valve	13	Control valve
4.2	Discharge valve	14	Cut-off valve
4.3	Tbt1: Upper temperature sensor of inertial storage tank (optional)	15	Filling valve
5	P_o: Zone 1 circulation pump	16	Discharge valve
6	P_s: Solar pump	17	Tap water inlet pipe
6.1	Tsolar: Solar temperature sensor (optional)	18	Hot water valve
6.2	Solar collector	19	Manifold/distributor
7	P_d: DHW recirculation pump	20	Bypass valve
8	T5: DHW tank temperature sensor (accessory)	FHL 1... n	Floor heating circuit
10	Expansion vessel	A	Indoor
11	Domestic hot water tank	B	Outdoor

- Space heating.**  
 The ON/OFF signal and the operation mode, as well as the temperature settings, are set on the control panel. P\_o keeps running as long as the unit is at ON for space heating, SV1 remains OFF.
- Domestic hot water heating.**  
 The ON/OFF signal and the target tank water temperature (T5S) are set on the control panel. P\_o stops as soon as the unit is at ON to heat the domestic hot water, SV1 remains ON.

- **TBH check (tank booster heater).**

The TBH function is set on the control panel (Chap. 10.1 "Overview of DIP switch settings. ").

- 1) When the TBH is enabled, TBH can be activated by means of the "FAST DHW" function on the control panel; in DHW mode, TBH will be activated automatically when the initial temperature T5 of the domestic hot water is too low or when the target temperature of the domestic hot water is too high at low room temperature.
- 2) When the TBH is enabled and M1M2 set = 1 on the control panel, the TBH will be activated if potential-free contact M1M2 closes.

- **Thermal solar system check.**

The hydraulic module recognises the thermal solar system signal by judging T<sub>solar</sub> or receiving the signal SL1SL2 from the control panel (see paragraph "Input Define." in chapter 10.5).

The recognition method can be set by means of the "15.8 SOLAR INPUT" on the control panel. See Chap. 10.5) "**For solar control unit contact:**" for wiring.

- 1) When T<sub>solar</sub> is enabled, the solar system is at "ON" when T<sub>solar</sub> is sufficiently high, P<sub>s</sub> starts to operate; the thermal solar system is OFF when T<sub>solar</sub> is low, P<sub>s</sub> stops.
- 2) When the control SL1SL2 is enabled, the thermal solar system activates (ON) after having received the solar control unit signal, P<sub>s</sub> starts to operate. Without the solar control unit signal, the thermal solar system deactivates (OFF), P<sub>s</sub> stops running.



The outlet water can reach a maximum temperature of 70°C, pay attention to burns.

---



Make sure to insert the 3-way valve (SV1) correctly. For further details, see section "Connection for other components." in chapter 9.7.

With room temperatures extremely low, the domestic hot water is only heated by TBH, which guarantees that the heat pump can be used for space heating with the maximum capacity.

---



Details on configuration of the storage tank for domestic hot water for low outdoor temperatures (T<sub>4DHWMIN</sub>) are found in paragraph "Setting "13.2 DHW MODE"." Chap. 10.5.

---

## 8.2 UNITS 4-16KW: APPLICATION 2.

The "6.1 ROOM THERMOSTAT" control for space heating or cooling can be set on the control panel. It can be set in three modes: "MODE SET"/"ONE ZONE"/"DOUBLE ZONE". The unit can be connected to a high-voltage room thermostat and to a low-voltage room thermostat. See 9.7 "For room thermostat:" for wiring (Chap. 10.5 "Room Thermostat" for the setting).

### One Zone Control.

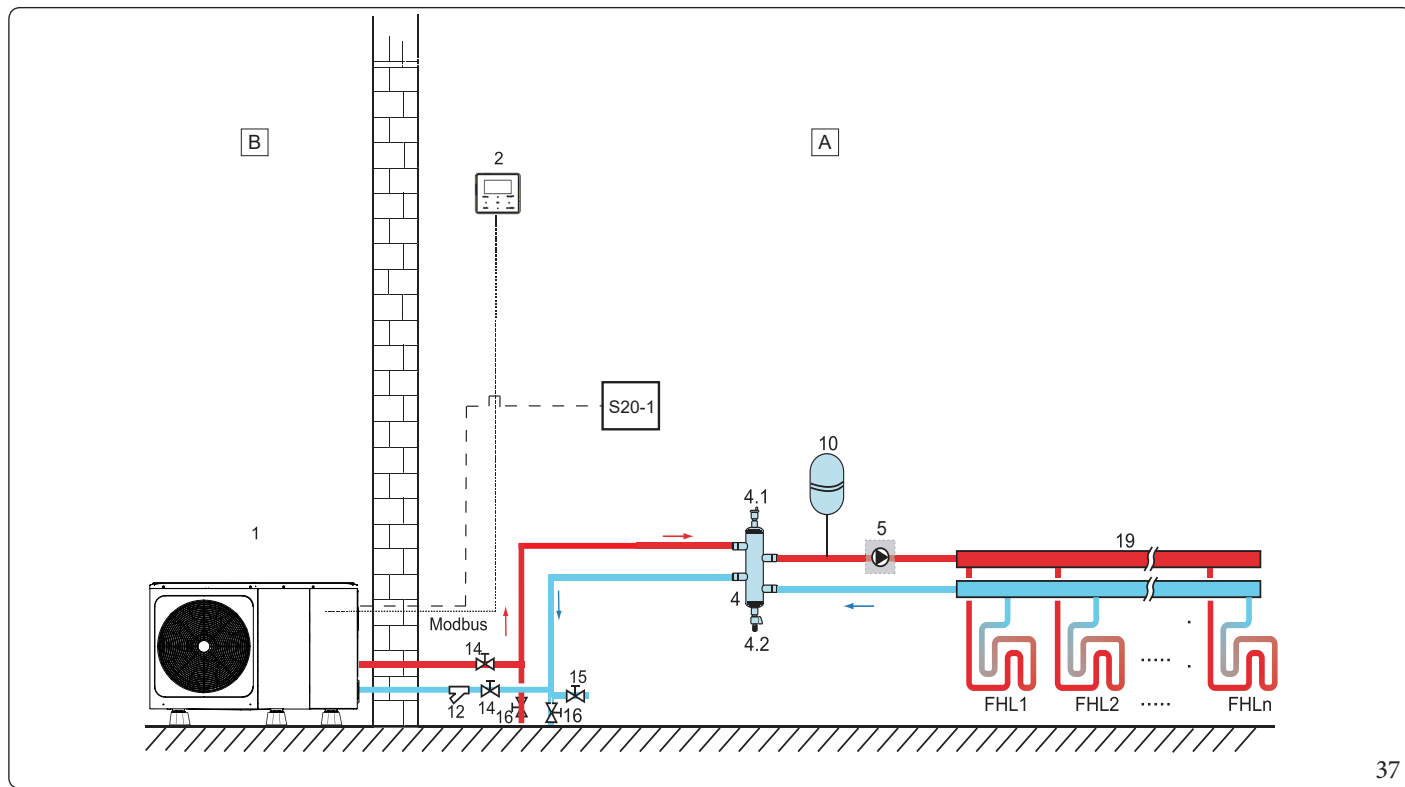

37

Pos.	Assembly unit	Pos.	Assembly unit
1	Main unit	14	Cut-off valve
2	Control panel	15	Filling valve
4	Inertial storage tank	16	Discharge valve
4.1	Automatic air purge valve	19	Manifold/distributor
4.2	Discharge valve	S20-1	Room thermostat
5	P_o: Zone 1 circulation pump	FHL 1... n	Floor heating circuit
10	Expansion vessel	A	Indoor
12	Filter (accessory)	B	Outdoor

- **Space heating.**

One zone control: the ON/OFF signal is controlled by the room thermostat, heating or cooling modes and the outlet water temperature are set on the control panel. The system is ON when "H" on the thermostat closes (\*). When "H" on the thermostat opens, the system switches OFF.

- **Circulation pumps operation.**

When the system is at ON, which means "H" on the thermostat closed, P\_o starts running;

When the system is OFF, which means "H" on the thermostat open, P\_o stops.

(\*): By H closed we mean: closed contact between H and L1 for the high-voltage room thermostat or closed contact between HT and COM for the low-voltage thermostat.

## Modsetting control.

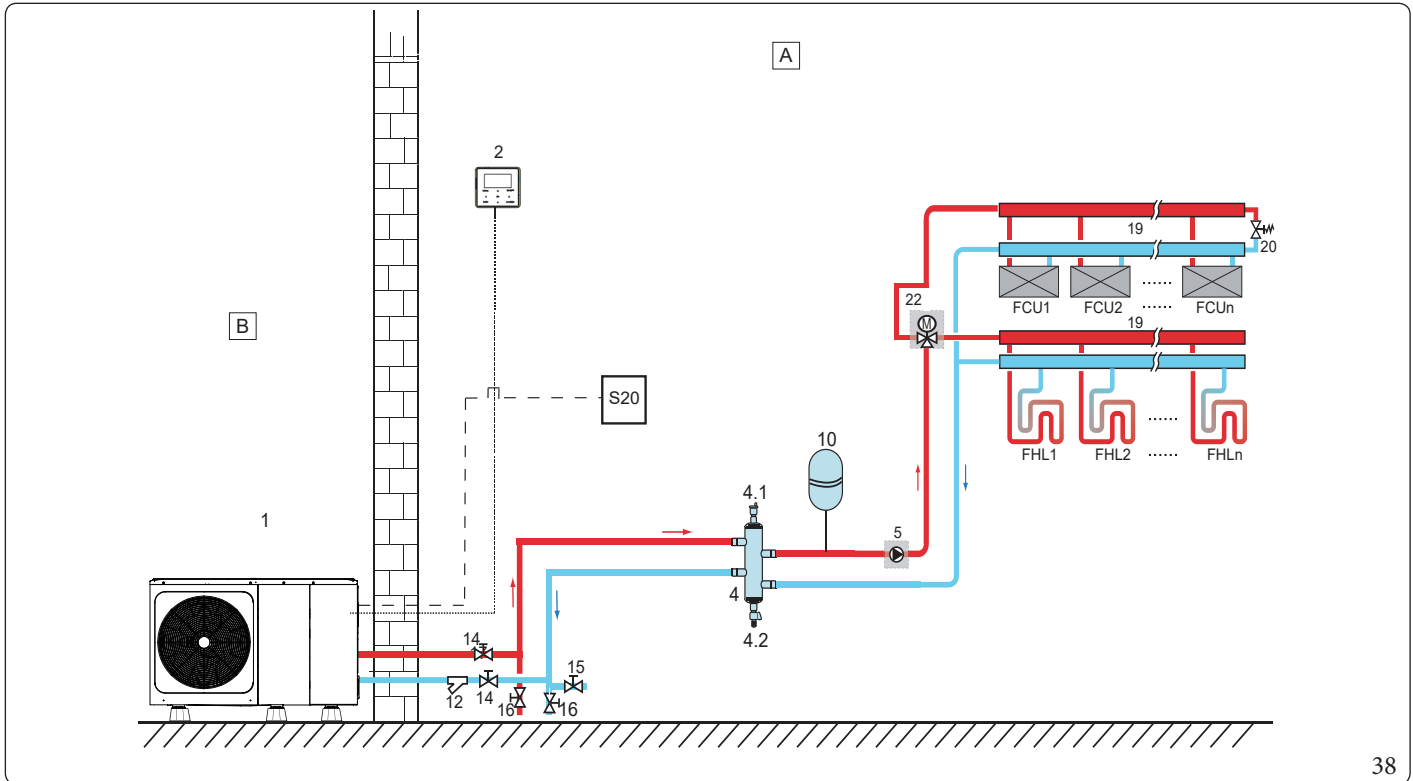

38

Pos.	Assembly unit	Pos.	Assembly unit
1	Main unit	16	Discharge valve
2	Control panel	19	Manifold/distributor
4	Inertial storage tank	20	Bypass valve
4.1	Automatic air purge valve	22	SV2: Summer/Winter 3-way valve
4.2	Discharge valve	S20	Room thermostat
5	P_o: Zone 1 circulation pump	FHL 1... n	Floor heating circuit
10	Expansion vessel	FCU 1... n	Fan coil
12	Filter (accessory)	A	Indoor
14	Cut-off valve	B	Outdoor

- **Space Heating/Cooling.**

The cooling or heating mode is set on the room thermostat, the water temperature is set on the user interface.

- 1) When "C" on the thermostat closes, the system will be set in cooling mode (\*).
- 2) When "H" on the thermostat closes and "C" opens, the system will be set in heating mode.

- **Circulation pumps operation.**

- 1) When the system is in cooling mode, which means "C" on the thermostat closed, SV2 remains OFF, P\_o starts to run.
- 2) When the system is in heating mode, which means "H" on the thermostat closed and "C" opened, SV2 remains ON, P\_o starts to run.

(\*): By C closed we mean: closed contact between C and L1 for the high-voltage room thermostat or closed contact between CL and COM for the low-voltage thermostat

## Doublezone control.

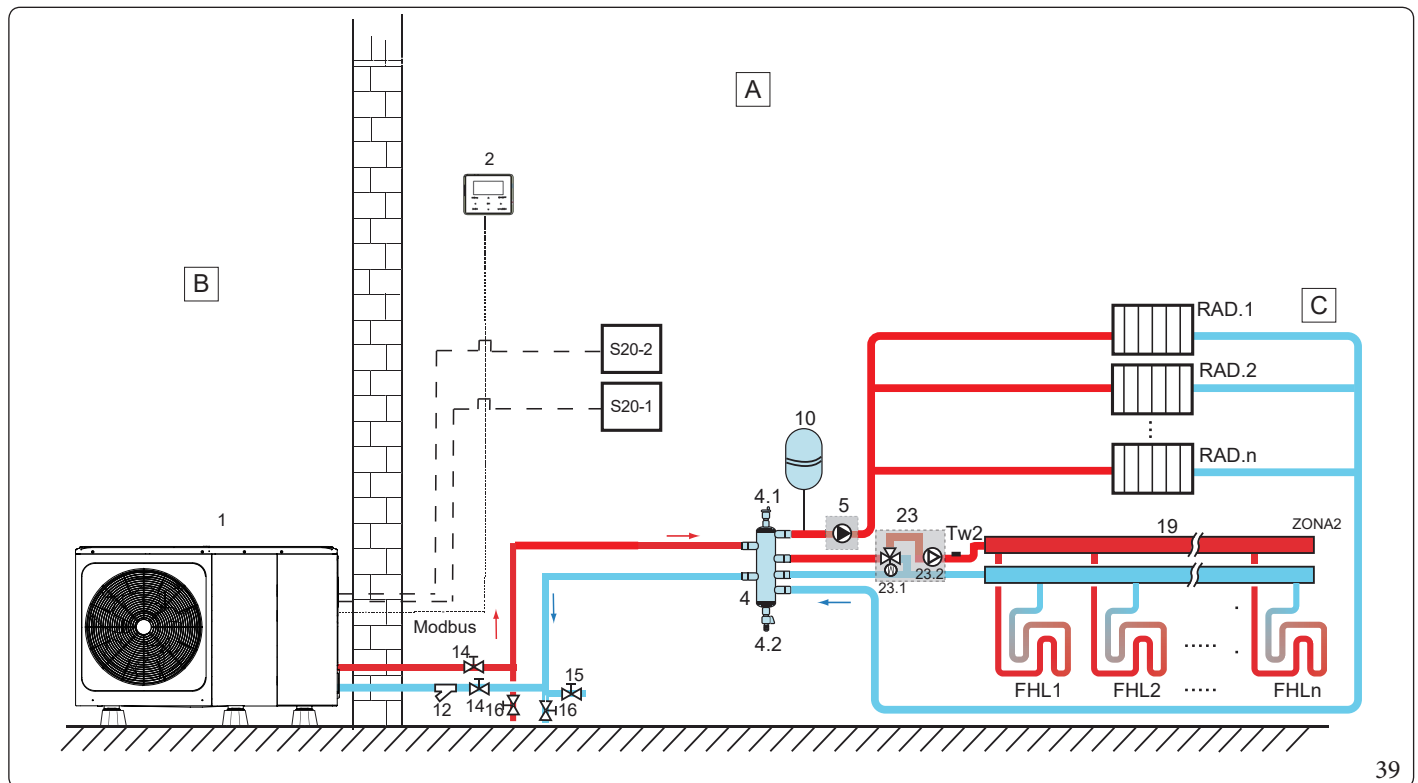

39

Pos.	Assembly unit	Pos.	Assembly unit
1	Main unit	19	Manifold/distributor
2	Control panel	23.1	SV3: Zone 2 mixing valve
4	Inertial storage tank	23.2	P_c: Zone 2 circulation pump
4.1	Automatic air purge valve	S20-1	Zone 1 Room thermostat
4.2	Discharge valve	S20-2	Zone 2 Room thermostat
5	P_o: Zone 1 circulation pump	Tw2	Zone 2 flow temperature sensor (optional)
10	Expansion vessel	FHL 1... n	Floor heating circuit
12	Filter (accessory)	RAD. 1... n	Radiator
14	Cut-off valve	A	Indoor
15	Filling valve	B	Outdoor
16	Discharge valve		

### • Space heating.

Zone 1 can operate in cooling mode or in heating mode, while Zone 2 can only operate in heating mode; upon installation, the thermostat in Zone 1 must be connected to "H". The thermostat in Zone 2 must be connected to "C".

- 1) Switching Zone 1 ON/OFF is controlled by the Zone 1 room thermostat. When "H" on the Zone 1 thermostat closes, Zone 1 switches ON. When "H" opens, Zone 1 switches OFF; the target temperature and the operation mode are set on the control panel.
- 2) In heating mode, switching Zone 2 ON/OFF is controlled by the Zone 2 room thermostat. When "C" on the Zone 2 thermostat closes, Zone 2 switches ON. When "C" opens, Zone 2 switches OFF. The target temperature is set on the control panel; Zone 2 can only operate in heating mode.

When cooling mode is set on the control panel, the Zone remains OFF:

- **Circulation pumps operation.**

When Zone 1 is ON, P<sub>o</sub> starts to run; when Zone 1 is OFF, P<sub>o</sub> stops.

When Zone 2 is ON, SV3 alternates between ON and OFF according to the set Tw2, P<sub>c</sub> remains ON; when Zone 2 is OFF, SV3 is OFF, P<sub>c</sub> stops.

The floor heating circuits require a lower water temperature in heating mode than the radiators or fan coil unit. The mixing valve and the zone 2 circulation pump are used to reach these two set points to adapt the water temperature based on the requirements of the floor heating circuits. The radiators are connected directly to the water circuit of the unit and the floor heating circuits are located after the mixing valve and the zone 2 circulation pump. The mixing valve and the zone 2 circulation pump are controlled by the unit.



- 1) Make sure to connect terminals SV2/SV3 correctly in the control panel; see Chap. 9.7 “**For the 3-way valves SV1, SV2 and SV3:**”.
  - 2) Connect the thermostat cables to the relative terminals and configure the "6.1 ROOM THERMOSTAT" correctly in the control panel. Wiring of the room thermostat should follow the A/B/C method as described in Chap. 9.7 “Connection for other components.”. for the room thermostat.
- 



- 1) Zone 2 can only run in heating mode. When cooling mode is set on the control panel and Zone 1 is OFF, “CL” in Zone 2 closes, the system remains OFF. The wires of the thermostats for Zone 1 and Zone 2 must be installed correctly.
  - 2) The drain valve must be installed at the lowest position of the pipe system.
-

### 8.3 UNITS 4-16KW: CASCADE SYSTEM.

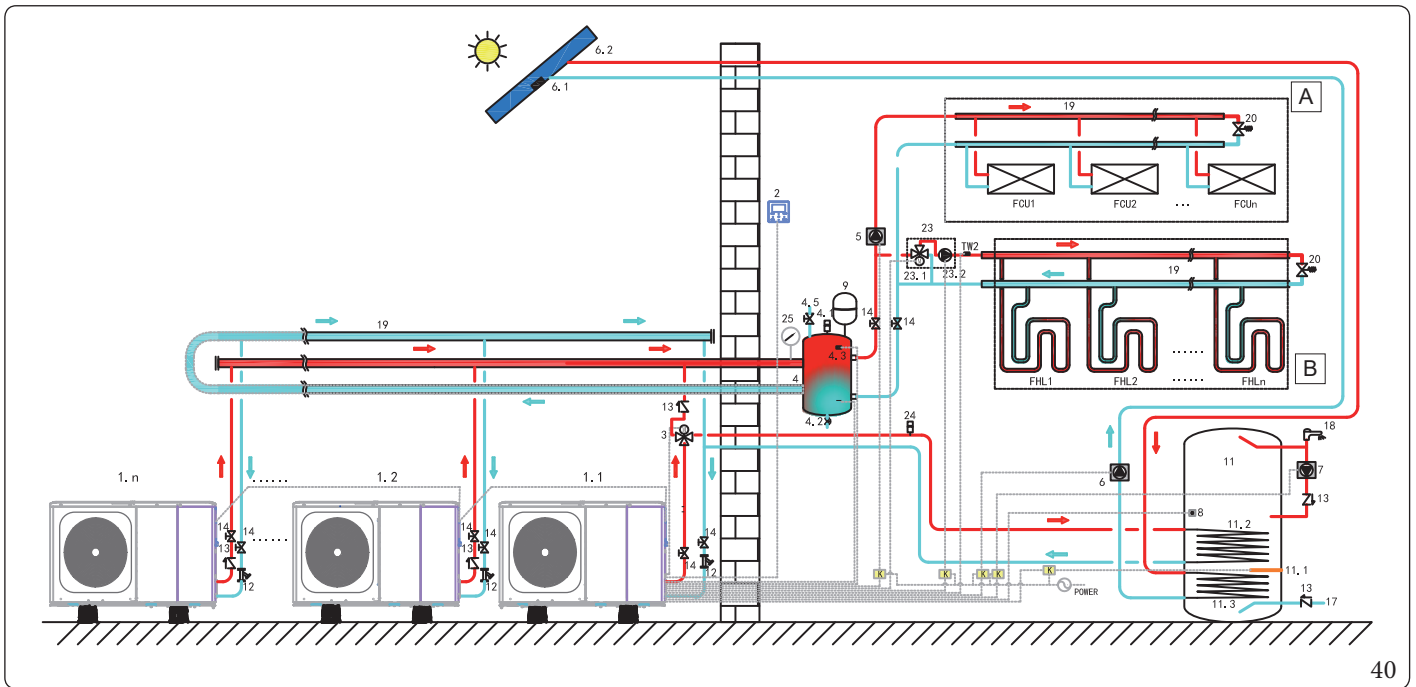

40

Pos.	Assembly unit	Pos.	Assembly unit
1.1	Master Unit	11.1	TBH: Heater of DHW storage tank
1.2... n	Slave Unit	11.2	DHW storage tank coil 1
2	Control panel	11.3	Coil 2 of DHW storage tank for thermal solar system
3	Sv1: 3-way valve for DHW tank	12	Filter (accessory)
4	Inertial storage tank	14	Cut-off valve
4.1	Automatic air purge valve	17	Tap water inlet pipe
4.2	Discharge valve	18	Hot water valve
4.3	Tbt1: Upper temperature sensor of inertial storage tank (optional)	19	Manifold/distributor
4.4	Tbt2: Temperature sensor lower than inertial storage tank (not used)	20	Bypass valve
4.5	Filling valve	23.1	SV3: Zone 2 mixing valve
5	P_o: Zone 1 circulation pump	23.2	P_c: Zone 2 circulation pump
6	P_s: Solar pump	24	Automatic air purge valve
6.1	Tsolar: Solar temperature sensor (optional)	25	Water pressure gauge
6.2	Solar collector	Tw2	Zone 2 flow temperature sensor (optional)
7	P_d: DHW recirculation pump	FHL 1... n	Floor heating circuit
8	T5: DHW tank temperature sensor (accessory)	A	Zone 1 = The zone works in cooling or heating mode
9	Expansion vessel	B	Zone 2 = The zone only works in heating mode
11	Domestic hot water tank		



- **Domestic hot water heating.**

Only the master unit (1.1) can function in "13.2 DHW MODE". T5S is set on the control panel (2). In DHW mode, SV1 (3) remains ON. When the master unit runs in DHW mode, the slave units can operate in space cooling/heating mode.

- **Space heating.**

All the slave units can work in space heating mode. The operation mode and temperature setpoint are set on the control panel (2). Due to the variations of the outdoor temperature and of the load required indoors, several outdoor units can operate at different times.

In cooling mode, SV3 (23.1) and P\_c (23.2) remain OFF. P\_o (5) remains ON.

In heating mode, when both ZONE1 and ZONE2 are working, P\_c (23.2) and P\_o (5) remain ON, SV3 (23.1) alternates between ON and OFF depending on the set Tw2.

In heating mode, when only ZONE1 works, P\_o (5) remains ON, SV3 (23.1) and P\_c (23.2) remain OFF.

- **TBH check (tank booster heater).**

The TBH must be set using the dip switches on the main board (refer to Chap. 10.1). The TBH is only controlled by the master unit. Refer to chapter 8.1 for the specific control of the TBH.

- **Thermal solar system check.**

The thermal solar system is only controlled by the master unit. Refer to chapter 8.1 for the specific control of the thermal solar system.



1. A maximum of 6 units can be connected in cascade in a system. One of them is the master unit, the others are slave units; the master unit and the slave units can be recognised by whether or not they are connected to the control panel during operation. The unit with control panel is the master unit, the units without control panel are slave units. Only the master units can operate in DHW mode. During installation, check the diagram of the cascade system and determine the master unit; before switching on, remove all the control panels of the slave units.
2. SV1, SV2, SV3, P\_o, P\_c, P\_s, T1, T5, Tw2, Tbt1, Tsolar, SL1SL2, TBH and the control panel must only be connected to the matching terminals on the main board of the master unit. See Chap. 9.3 "Main control panel of hydraulic module." and 9.7 "Connection for other components."
3. The system is equipped with the self-addressing function. After being switched on the first time, the masters unit assigns the addresses for the slave units. The slave units will maintain the addresses. After being switched back on, the slave units will still use the prior addresses. It is not necessary to set the addresses of the slave units again.
4. If an Hd error occurs, refer to Chap. 13.4.
5. It is recommended to use the inverted water return system to avoid hydraulic unbalance between each unit in a cascade system.



1. In a cascade system, the sensor Tbt1 must be connected to the master unit and Tbt1 set as active (ON) on the control panel (see Chap. 10.5 "Input Define."). Otherwise none of the slave units will work.
2. If the zone 1 circulation pump needs to be connected in series in the system when the head of the internal water pump is not sufficient, it is recommended to install the zone 1 circulation pump after the inertial storage tank.
3. Please make sure that the maximum ignition time interval of all units does not exceed 2 minutes, otherwise the time for the request and assignment of the addresses will not be reached, which could make it impossible for the slave units to communicate normally, triggering an Hd error.
4. A maximum of 6 units can be connected in cascade in a system.
5. The outlet pipe of each unit must be installed with a non-return valve.

**Inertial storage tank volume requirement.**

Model	Inertial storage tank (L)
4-16 kW	≥ 40
cascade system	≥ 40*n
n = number of units	

## 9 OVERVIEW OF THE UNIT.

### 9.1 DISASSEMBLING THE UNIT.

Models 4-16kW.

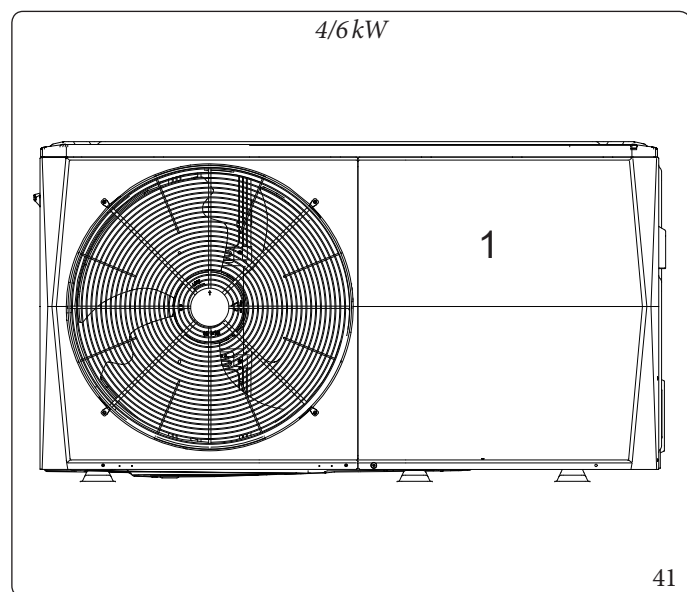

Key (Fig. 41):

Port 1 - To access the compressor, the electric parts and the hydraulic compartment.

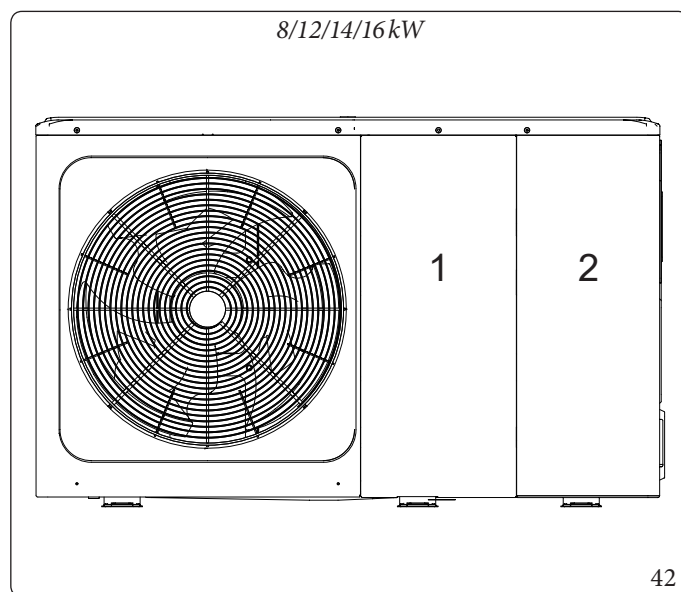

Key (Fig. 42):

Port 1 - To access the compressor and the electric components.

Port 2 - To access the compressor, the hydraulic compartment and the electric components.



- Disconnect the unit from the power supply before removing doors 1 and 2.
- The components inside the unit could be hot.

## 9.2 MAIN COMPONENTS.

### Hydraulic module 4-6kW and 8-16kW.

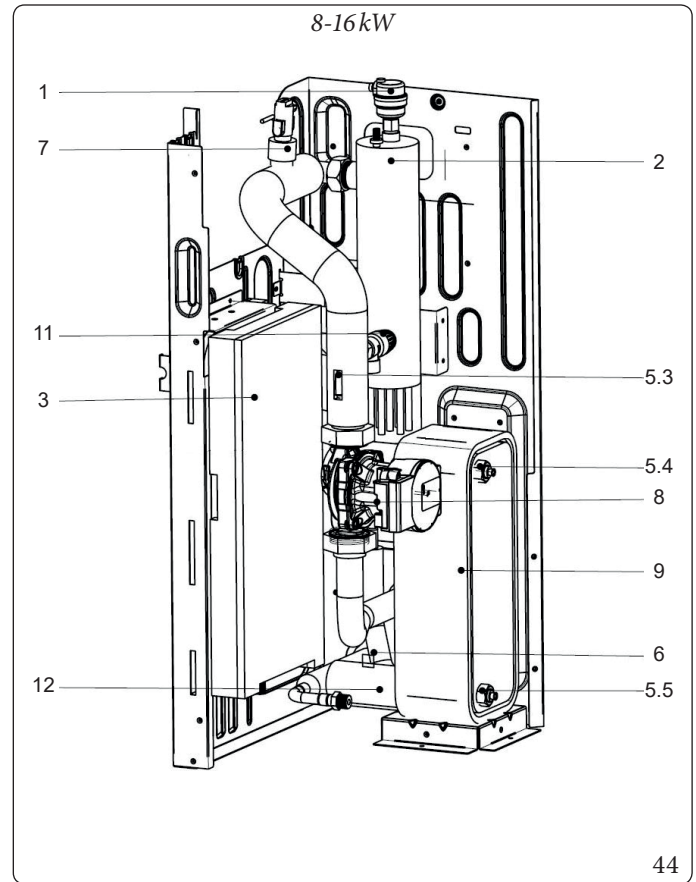
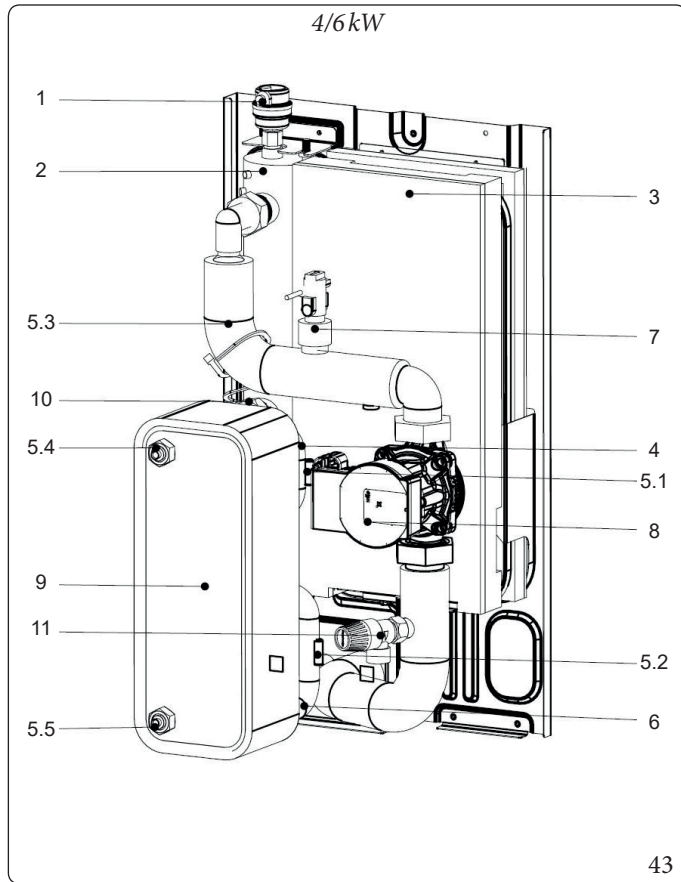

Pos.	Assembly unit	Description
1	Automatic air purge valve	The residual air in the water circuit will be removed automatically from the water circuit.
2	Backup heater	Provides additional heating capacity when the heat pump's heating capacity is insufficient due to very low outdoor temperature.
3	Expansion vessel	Balances the pressure of the water system (Volume of expansion vessel 8 L).
4	Refrigerant gas pipe	-
5	Temperature sensors	Four temperature sensors determine the temperature of the water and of the refrigerant at the various points of the water circuit. 5.1-T2B; 5.2-T2; 5.3-T1(optional); 5.4-TW_out; 5.5-TW_in.
6	Refrigerant liquid pipe	-
7	Flow switch	Detects the water flow rate to protect the compressor and the water pump in case of insufficient water flow.
8	Pump	Circulates the water in the hydronic circuit.
9	Plate heat exchanger	Transfers the heat of the refrigerant (R32) to the hydronic circuit.
10	Water outlet pipe	-
11	Pressure relief valve	Prevents overpressure of the water by opening at 3 bar and draining water from the water circuit.
12	Water inlet pipe	-

### 9.3 ELECTRONIC CONTROL BOX.

Models 4-6kW.

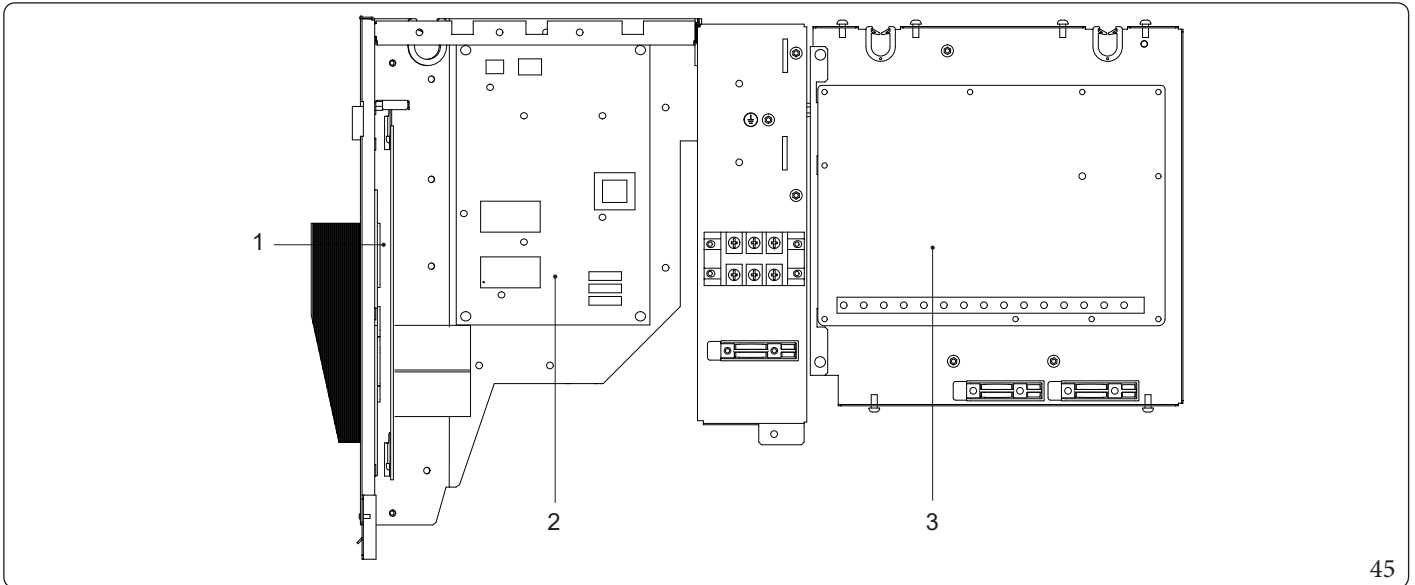

Key (Fig. 45):

- 1 - Control board of Inverter module (PCBA)
- 2 - Main control board of system with heat pump (PCBB)
- 3 - Main control board of hydraulic module

8kW model.

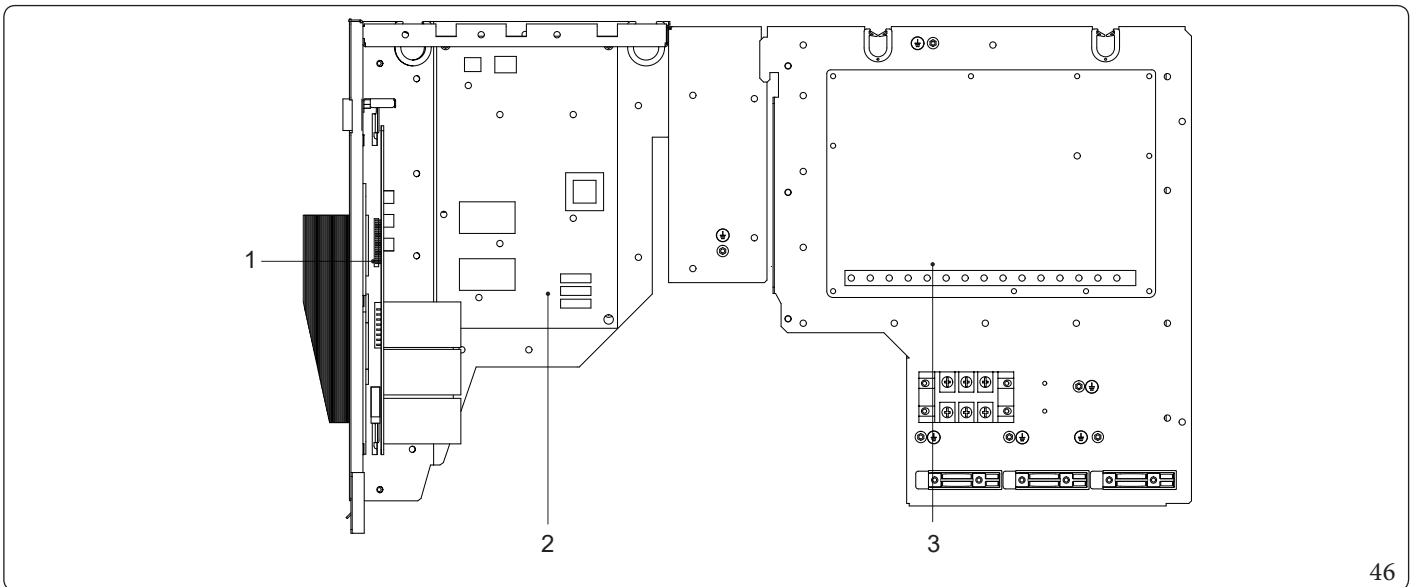

Key (Fig. 46):

- 1 - Control board of Inverter module (PCBA)
- 2 - Main control board of system with heat pump (PCBB)
- 3 - Main control board of hydraulic module

### Three-phase models 12-14-16kW.

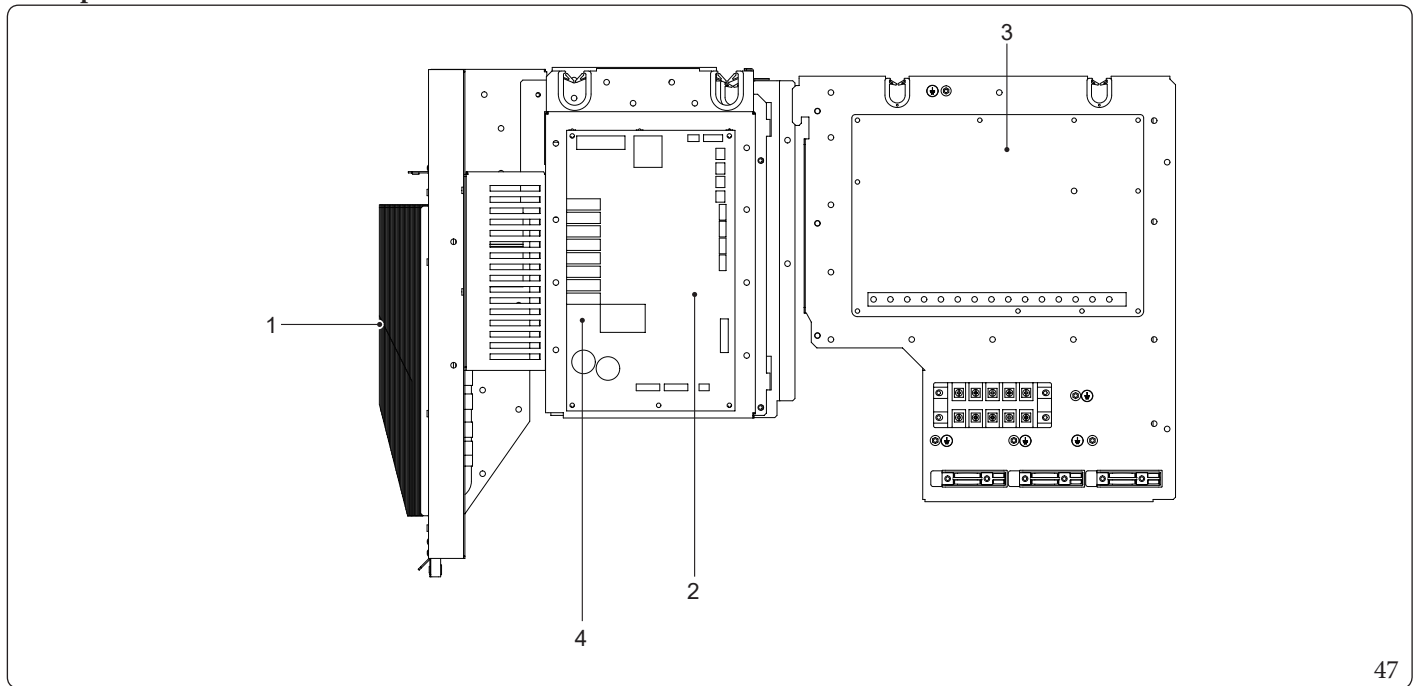

Key (Fig. 47):

- 1 - Control board of Inverter module (PCBA)
- 2 - Main control board of system with heat pump (PCBB)
- 3 - Main control board of hydraulic module
- 4 - Filter board (PCBC) (on the back of PCBB, only for three-phase unit)

### Main control panel of hydraulic module.

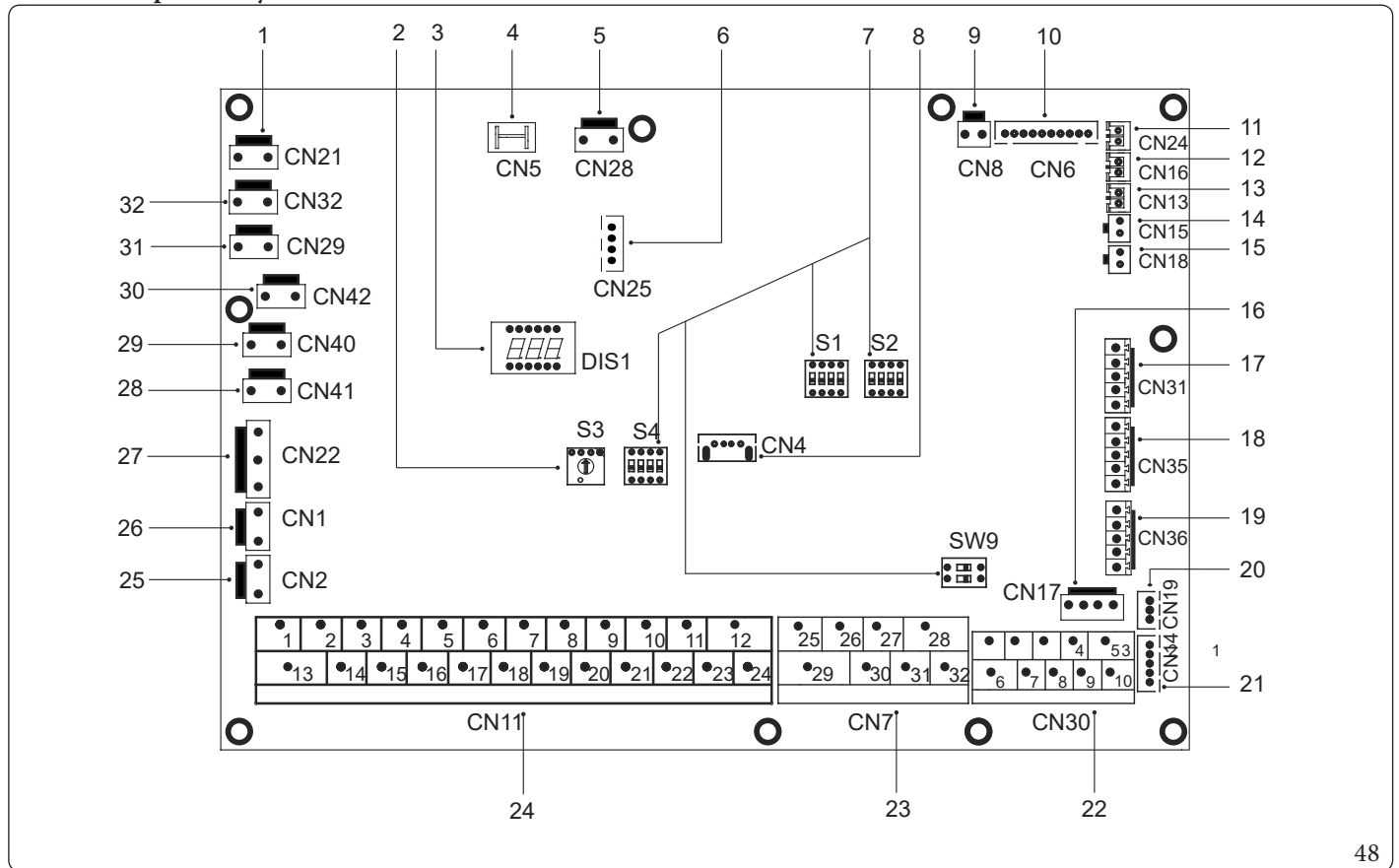

48

No.	Port	Code	Assembly unit
1	CN21	HEAT	Power supply port
2	S3	-	Not used
3	DIS1	-	Digital display
4	CN5	EARTH	Earth port
5	CN28	PUMP	Variable speed pump power input port
6	CN25	DEBUG	IC programming port
7	S1,S2,S4,SW9	-	DIP Switch
8	CN4	USB	USB programming port
9	CN8	FS	Flow switch port
10	CN6	T2	Port for refrigerant liquid side temperature sensors (heating mode)
		T2B	Port for refrigerant gas side temperature sensors (cooling mode)
		TW_in	Port for inlet water temperature sensors of plate heat exchanger
		TW_out	Port for outlet water temperature sensors of plate heat exchanger
		T1	Port for flow temperature sensor
11	CN24	Tbt1	Port for upper temperature sensor of inertial storage tank
12	CN16	Tbt2	Not used

No.	Port	Code	Assembly unit
13	CN13	T5	Port for domestic hot water temperature sensor
14	CN15	Tw2	Port for zone 2 flow temperature sensor
15	CN18	solarT	Port for solar collector lower temperature sensor
16	CN17	POMPA_BP	Port for variable speed pump communication
17	CN31	HT	Room thermostat control port (heating mode)
		COM	Room thermostat power supply port
		CL	Room thermostat control port (cooling mode)
18	CN35	SG	SMART GRID port (grid signal)
		EVU	SMART GRID port (photovoltaic signal)
19	CN36	M1 M2	Port for unit disabling switch
		T1 T2	Not used
20	CN19	PQ	Not used
21	CN14	ABXYE	Port for communication with control panel
22	CN30	1 2 3 4 5	Port for communication with control panel
		6 7	Not used
		9 10	Port for machines in cascade
23	CN7	26 30	Compressor operation
		31 32	Port for alarm signal / Defrosting operation
		25 29	Not used
		27 28	Not used
24	CN11	1 2	Input port for thermal solar system (SL1 SL2)
		3 4 15	Room thermostat port
		5 6 16	Port for SV1 (3-way valve for DHW tank)
		7 8 17	Port for SV2 (Summer/Winter 3-way valve)
		9 21	Port for zone 2 pump
		10 22	Port for zone 1 circulation pump
		11 23	Port for thermal solar circuit pump
		12 24	Port for DHW recirculation pump
		13 16	Control port for DHW tank booster heater (TBH)
		14 17	Not used
18 19 20	Port for SV3 Zone 2 (3-way) mixing valve		
25	CN2	TBH_FB	Feedback port for external thermostat (in default short-circuit)
26	CN1	IBH1/2_FB	Feedback port for thermostat (in default short-circuit)
27	CN22	IBH1	Port for backup heater
		IBH2	Reserved
		TBH	Control port for DHW tank booster heater (TBH)
28	CN41	CALDO8	Port for anti-freeze electric heating tape (internal)
29	CN40	CALDO7	Port for anti-freeze electric heating tape (internal)
30	CN42	CALDO6	Port for anti-freeze electric heating tape (internal)
31	CN29	CALDO5	Port for anti-freeze electric heating tape (internal)
32	CN32	IBH0	Port for backup heater

Single phase for 4-8 kW units.

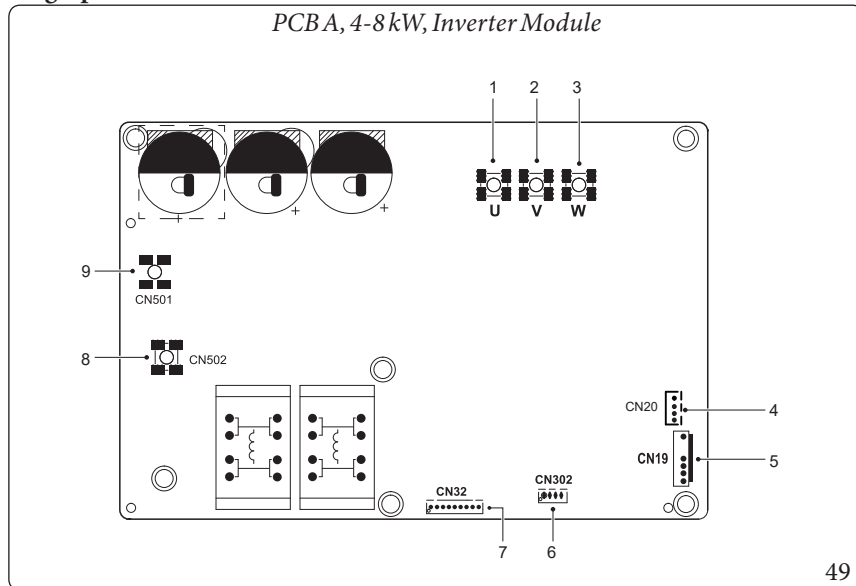

For 4-6 kW, two capacitors

Pos.	Assembly unit	Pos.	Assembly unit
1	U compressor connection port	6	Reserved (CN302)
2	V compressor connection port	7	Port for communication with PCB B (CN32)
3	W compressor connection port	8	Input port N for rectifier link (CN502)
4	Output port for +12V/9V (CN20)	9	Input port L for rectifier link (CN501)
5	Fan port (CN19)	/	/



PCB B, main control board of heat pump system

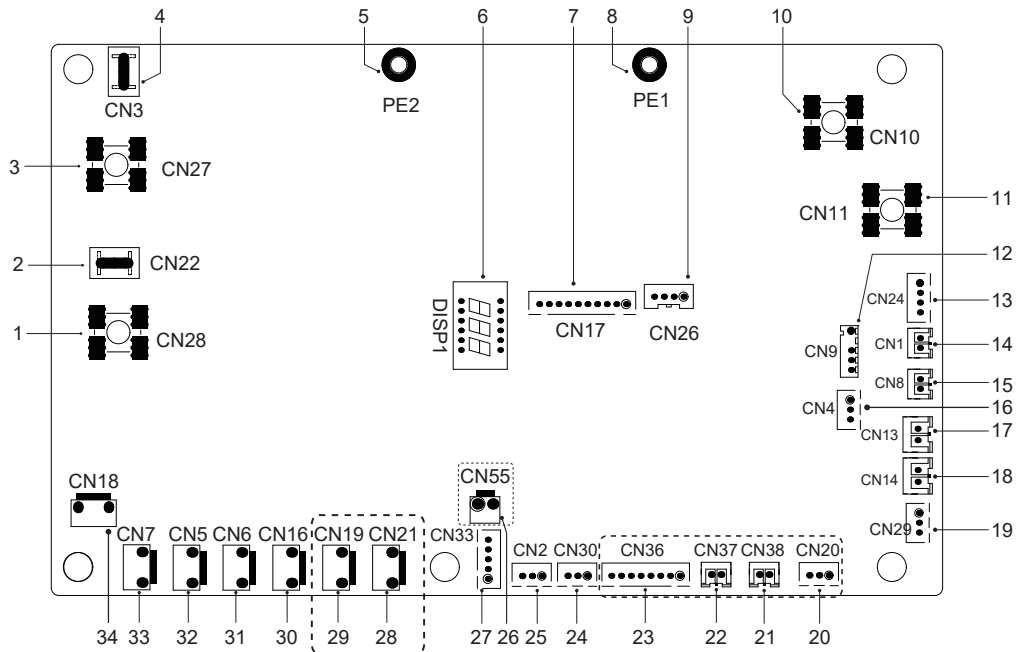

50

Pos.	Assembly unit	Pos.	Assembly unit
1	Output port L to PCB A (CN28)	18	Port for low pressure switch (CN14)
2	Reserved (CN22)	19	Port for communication with hydro-box control board (CN29)
3	Output port L to PCB A (CN27)	20	Reserved (CN20)
4	Reserved (CN3)	21	Reserved (CN38)
5	Port for earth cable (PE2)	22	Reserved (CN37)
6	Digital display (DSP1)	23	Reserved (CN36)
7	Port for communication with PCB A (CN17)	24	Port for communication (reserved CN30)
8	Port for earth cable (PE1)	25	Port for communication (reserved CN2)
9	Reserved (CN26)	26	Reserved (CN55)
10	Input port for neutral cable (CN10)	27	Port for electric expansion valve (CN33)
11	Input port for live cable (CN11)	28	Reserved (CN21)
12	Port for external room temperature sensor and condenser temperature sensor (CN9)	29	Reserved (CN19)
13	Output port for +12V/9V (CN24)	30	Condensate antifreeze heating cable port (CN16)
14	Port for intake temperature sensor (CN1)	31	Port for 4-way valve (CN6)
15	Port for drain temperature sensor (CN8)	32	Port for SV6 valve (CN5)
16	Port for pressure sensor (CN4)	33	Port for compressor 1 electric heating tape (CN7)
17	Port for high pressure switch (CN13)	34	Port for compressor 2 electric heating tape (CN18)

Three phase for units 12-14-16kW.

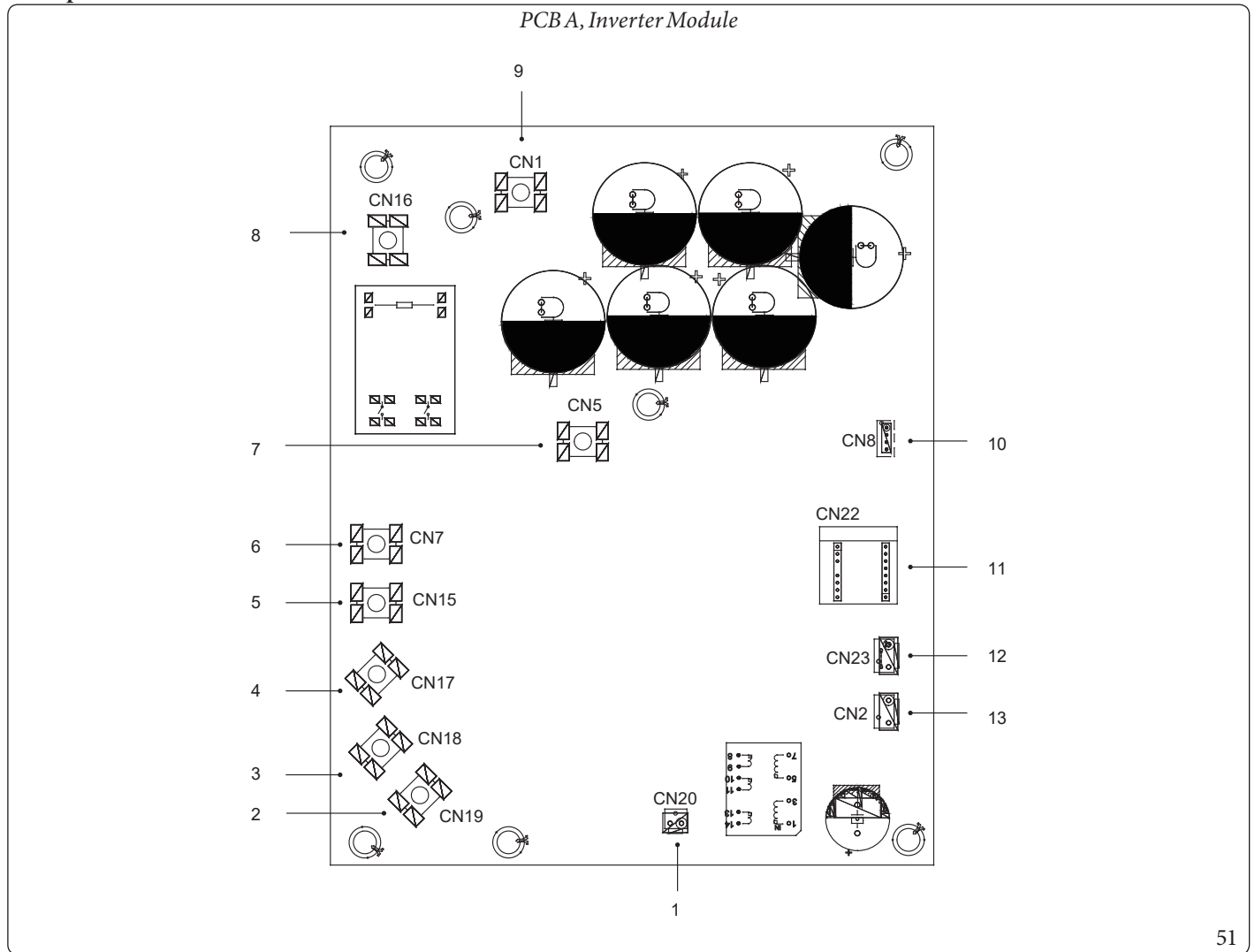

Pos.	Assembly unit	Pos.	Assembly unit
1	Output port for +15V (CN20)	8	L1 power supply input port (CN16)
2	W compressor connection port (CN19)	9	P_in input port for IPM module (CN1)
3	V compressor connection port (CN18)	10	Port for communication with PCBB (CN8)
4	U compressor connection port (CN17)	11	PED board (CN22)
5	L3 power supply input port (CN15)	12	Port for high pressure switch (CN23)
6	L2 power supply input port (CN7)	13	Port for communication with PCBC (CN2)
7	Input port P_out for IPM module (CN5)		

PCBB, main control board of heat pump system

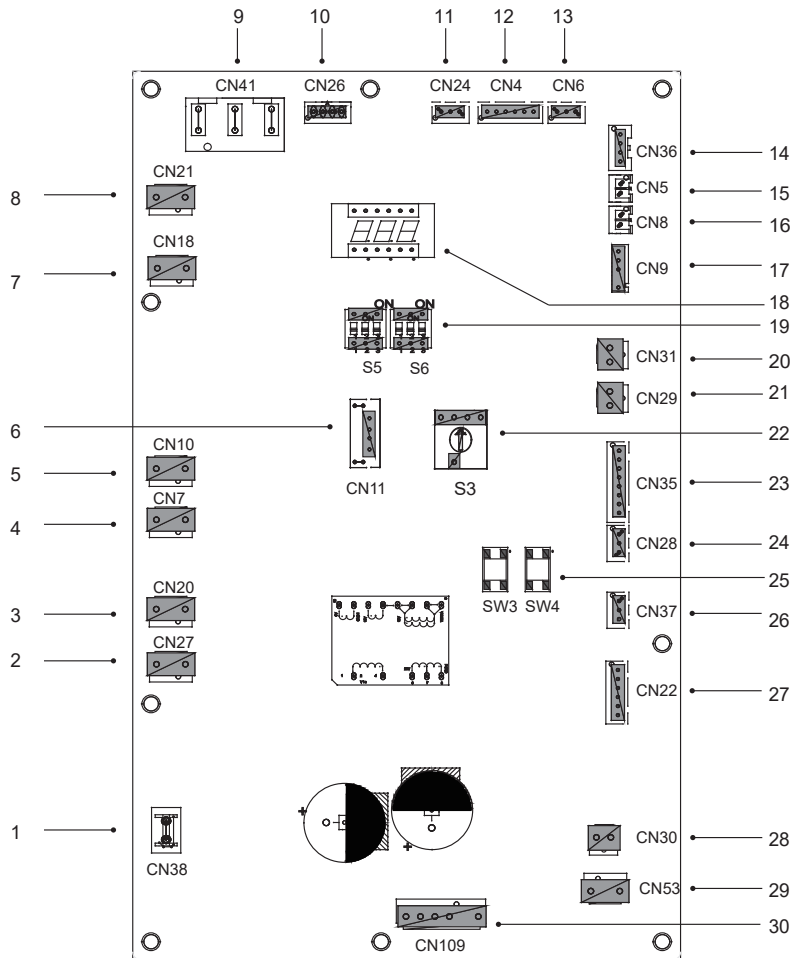

52

Pos.	Assembly unit	Pos.	Assembly unit
1	Port for earth cable (CN38)	16	Port for Tp temperature sensor (CN8)
2	Port for 2-way valve 6 (CN27)	17	Port for external room temperature sensor and condenser temperature sensor (CN9)
3	Port for 2-way valve 5 (CN20)	18	Digital display (DSP1)
4	Condensate antifreeze heating cable port (CN7)	19	Dip switch (SS.S6)
5	Port for electric heating tape 1 (CN10)	20	Port for low pressure switch (CN31)
6	Reserved (CN11)	21	Port for high pressure switch and quick check (CN29)
7	Port for 4-way valve (CN18)	22	Rotary Dip switch (S3)
8	Reserved (CN21)	23	Port for outlet water temperature sensors of plate heat exchanger
9	Power supply port from PCB C (CN41)	24	Port for XYE communication (CN28)
10	Port for communication with power meter (CN26)	25	Keys for forced cooling and control (SW3, SW4)
11	Port for communication with hydro-box control board (CN24)	26	Port for H1H2E communication (CN37)
12	Port for communication with PCB C (CN4)	27	Port for electric expansion valve (CN22)
13	Port for pressure sensor (CN6)	28	Port for fan 15VDC power supply (CN30)
14	Port for communication with PCB A (CN36)	29	Port for fan 31VDC power supply (CN53)
15	Port for Th temperature sensor (CN5)	30	Fan port (CN109)

PCBC, Three-phase filter board 12/14/16kW

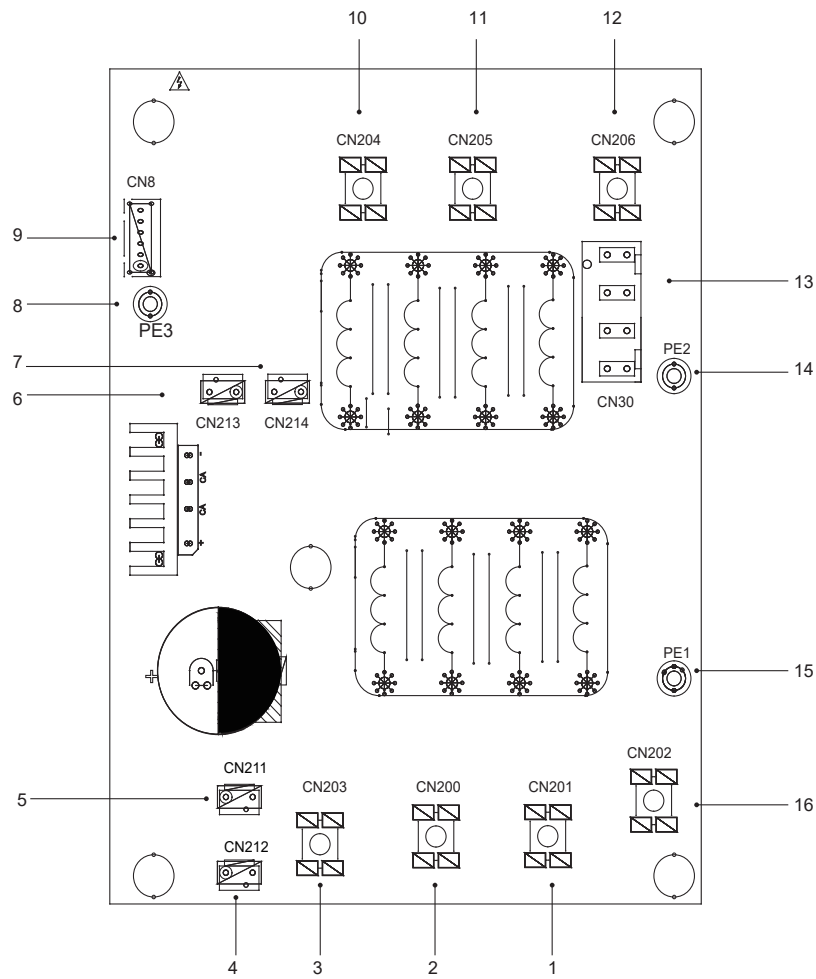

53

Pos.	Assembly unit	Pos.	Assembly unit
1	L2 power supply (CN201)	9	Port for communication with PCB B (CN8)
2	L3 power supply (CN200)	10	L3 filtering power (L3)
3	N power supply (CN203)	11	L2 filtering power (L2)
4	31VDC power supply port (CN212)	12	L1 filtering power (L1)
5	Reserved (CN211)	13	Power supply port for main control board (CN30)
6	Port for fan reactor (CN213)	14	Port for earth cable (PE2)
7	Power supply port for Inverter module (CN214)	15	Port for earth cable (PE1)
8	Earth cable (PE3)	16	L1 power supply (L1)

**Control components for the backup heater (IBH)**

*4/6kW single-phase with backup heater (3kW single-phase)*

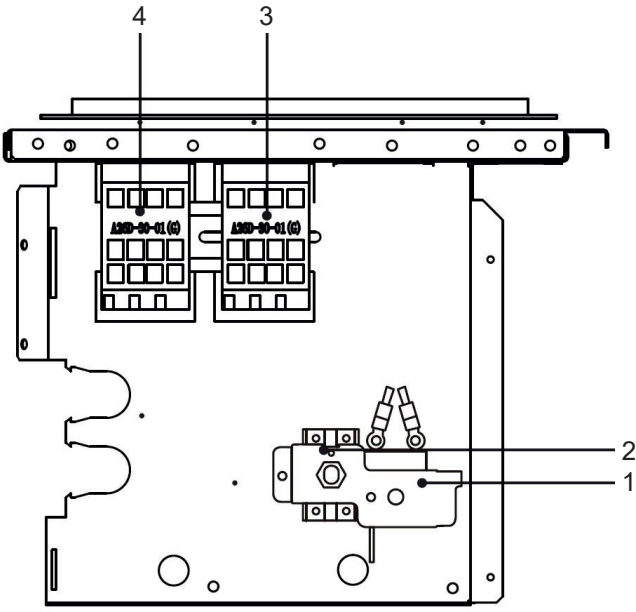

54

*12-16kW three-phase with backup heater (9kW)*

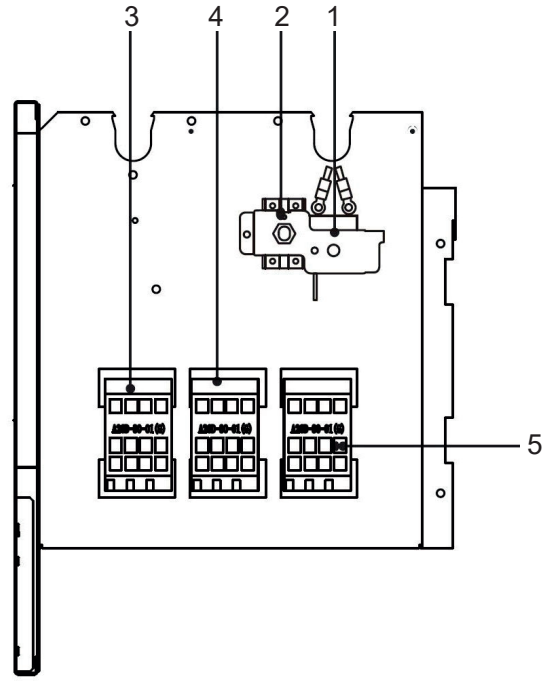

56

*8kW single-phase with backup heater (3kW single-phase)*

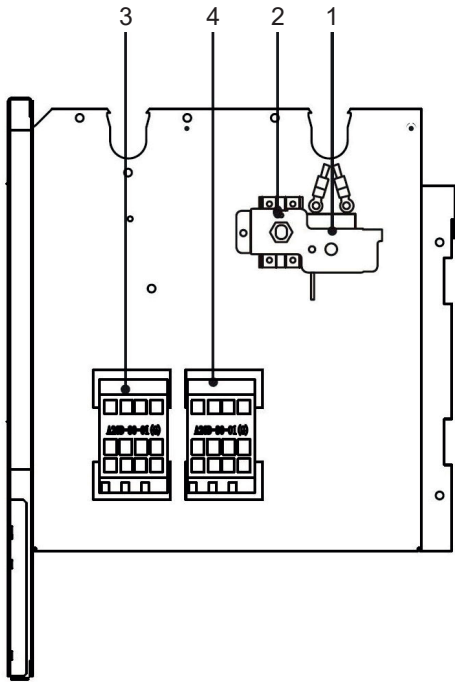

55

Pos.	Assembly unit	Pos.	Assembly unit
1	Automatic thermal protection	4	KM2 backup heater contactor
2	Manual thermal protection	5	KM3 backup heater contactor
3	KM1 backup heater contactor		

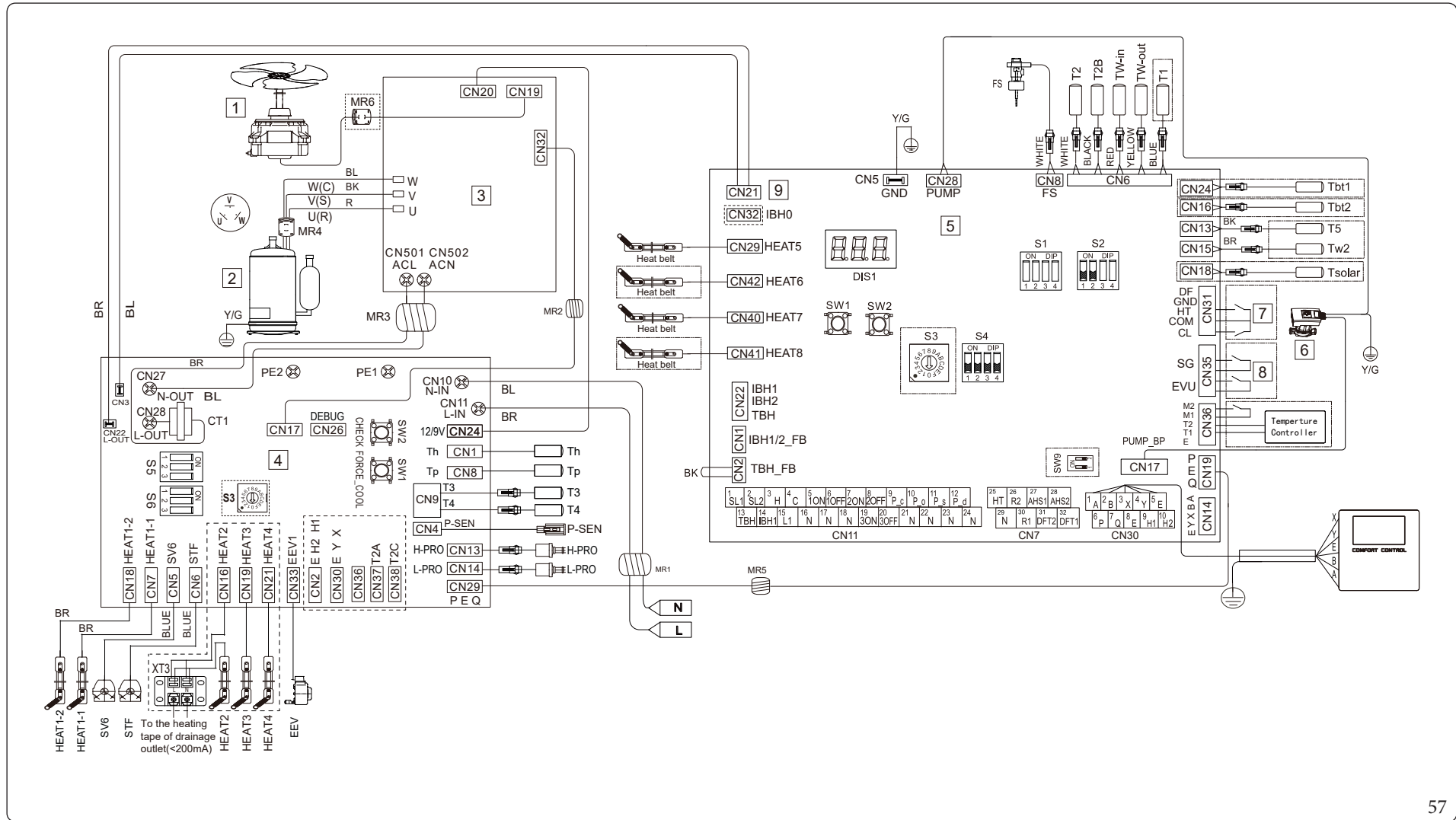

Key (Fig. 57):

- 1 - Fan
- 2 - Compressor
- 3 - PCBA, single phase Inverter control board
- 4 - PCBB, main control board of single phase
- 5 - Main control board of hydraulic module

- 6 - Pump
- 7 - Room thermostat (low voltage)
- 8 - Smart Grid (low voltage)
- 9 - Power supply
- HEAT2- Condensate antifreeze heating cable

Colour code key (Fig. 57):

- BK - Black
- BL - Blue
- BR - Brown
- G/Y - Yellow/Green
- R - Red
- W - White
- Y - Yellow

3 kW IBH (1 step control) (4-8 kW unit)

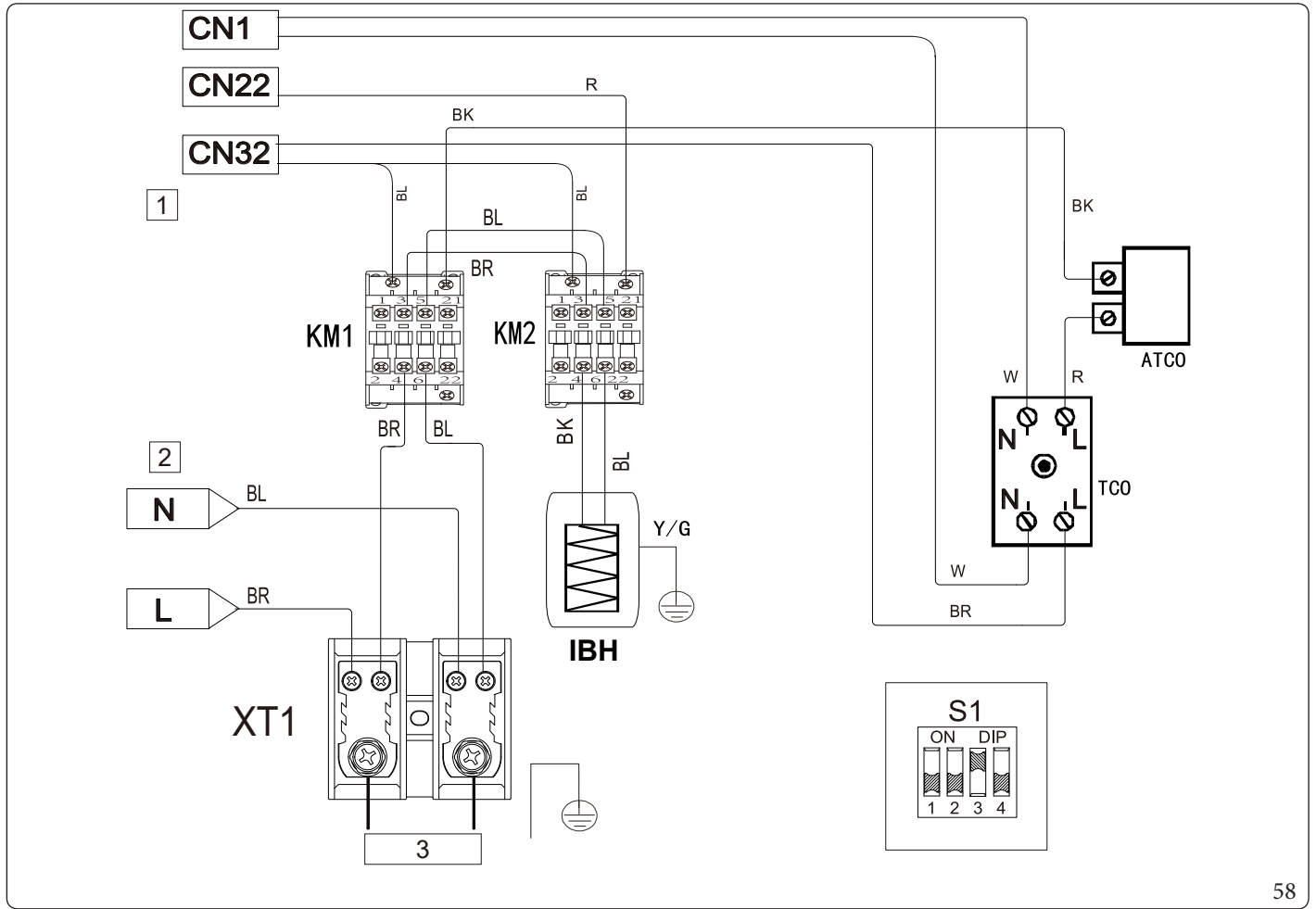

58

Key (Fig. 58):

- 1 - To the hydraulic module main control board
- 2 - To the heat pump system main control board
- 3 - 220-240 Vac power supply

Colour code key (Fig. 58):

- BK - Black
- BL - Blue
- BR - Brown
- G/Y - Yellow/Green
- R - Red
- W - White
- Y - Yellow



After switch-off, wait 5 minutes before restarting the appliance.

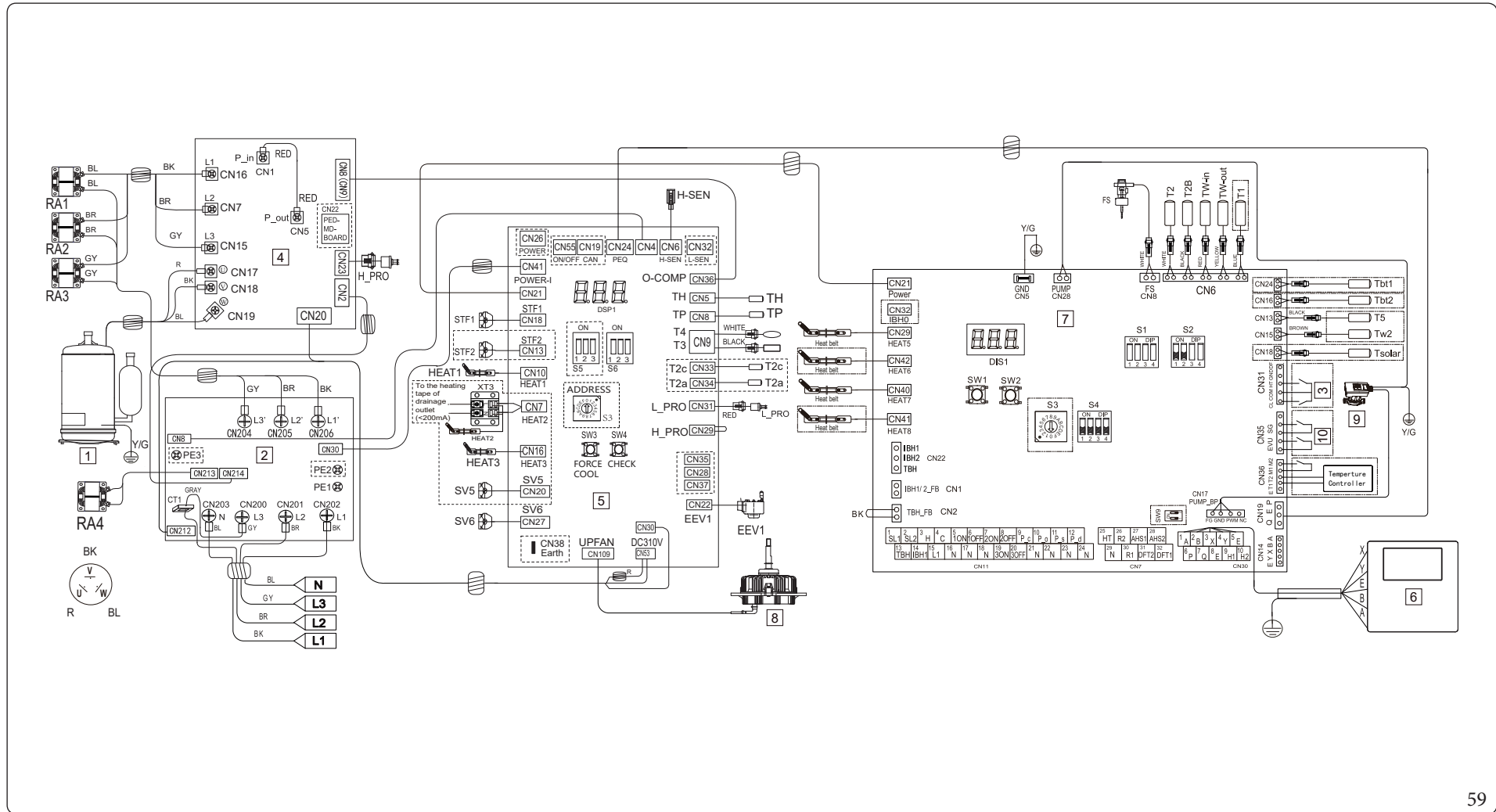

Key (Fig. 59):

- 1 - Compressor
- 2 - Filter board
- 3 - Room thermostat (low voltage)
- 4 - Inverter control board
- 5 - Heat pump system main control board

- 6 - Control panel
- 7 - Main control board of hydraulic module
- 8 - Fan
- 9 - Pump
- 10 - Smart Grid (low voltage)
- HEAT2 - Condensate antifreeze heating cable

Key (Fig. 59):

- BK - Black
- BL - Blue
- BR - Brown
- G/Y - Yellow/Green
- R - Red
- W - White
- Y - Yellow
- GY - Grey



9kW IBH (3 step control) (12-16kW T unit)

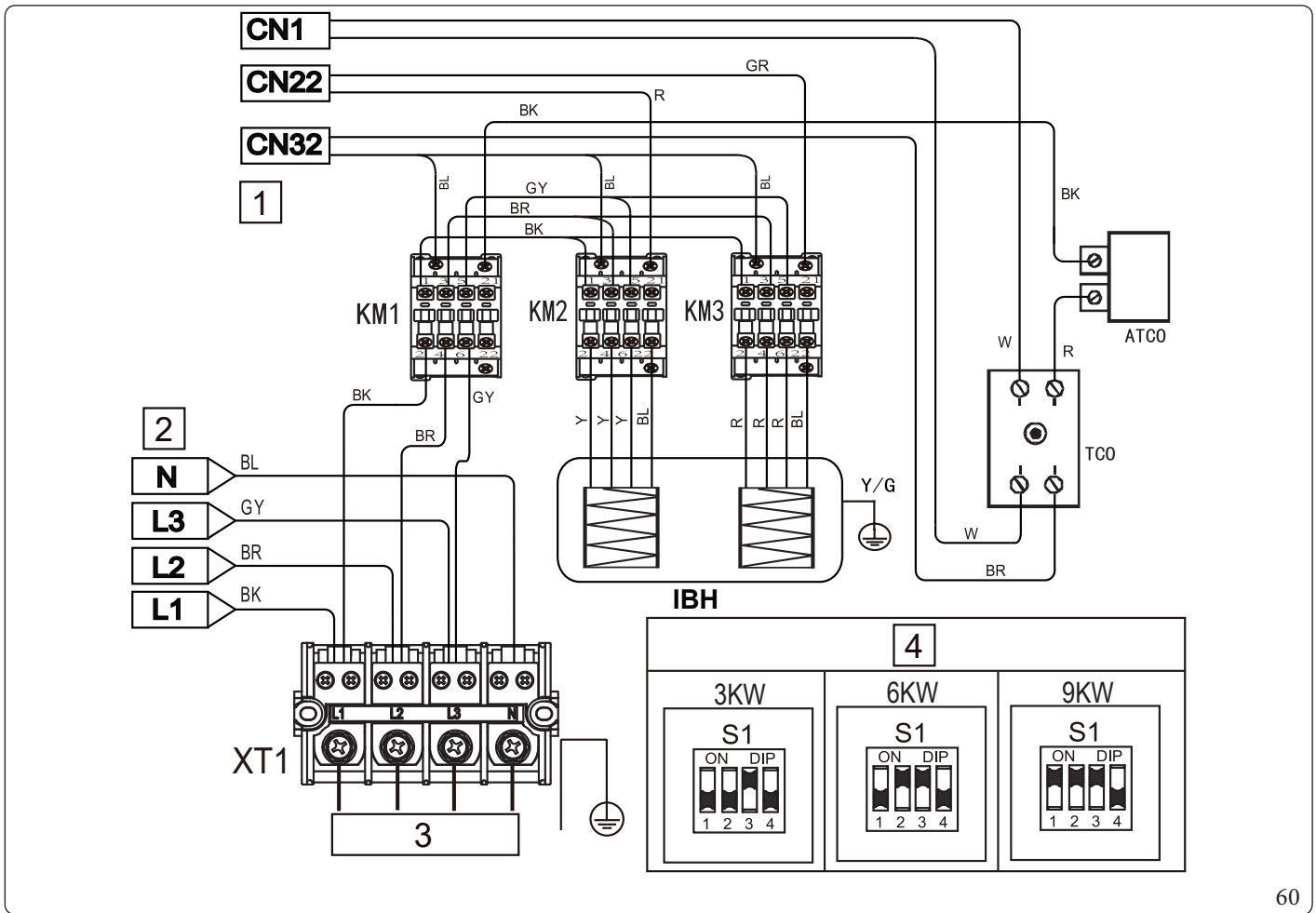

60

Key (Fig. 60):

- 1 - To the hydraulic module main control board
- 2 - To the filter board
- 3 - 380-4150 3N~ power supply
- 4 - S1 switches settings

Colour code key (Fig. 60):

- BK - Black
- BL - Blue
- BR - Brown
- G/Y - Yellow/Green
- R - Red
- W - White
- Y - Yellow
- G - Green



After switch-off, wait 5 minutes before restarting the appliance.

## 9.4 WATER PIPES.

All the lengths and distances from the pipes have been taken into consideration.



### Requirements

The maximum admissible length of the cable of the temperature probe is 20 m. This is the maximum admissible distance between the domestic hot water storage tank and the unit (only for installations with domestic hot water storage tank). The cable of the probe supplied with the domestic hot water storage tank is 10 m long. To enhance efficiency, it is recommended to install the 3-way valve and the domestic hot water storage tank as close to the unit as possible.



If the system is supplied with a domestic hot water storage tank, see the use and maintenance manual of the domestic hot water storage tank. If there is no glycol (anti-freeze) in the system, there is a power or pump failure; empty the system (as shown in the figure below).

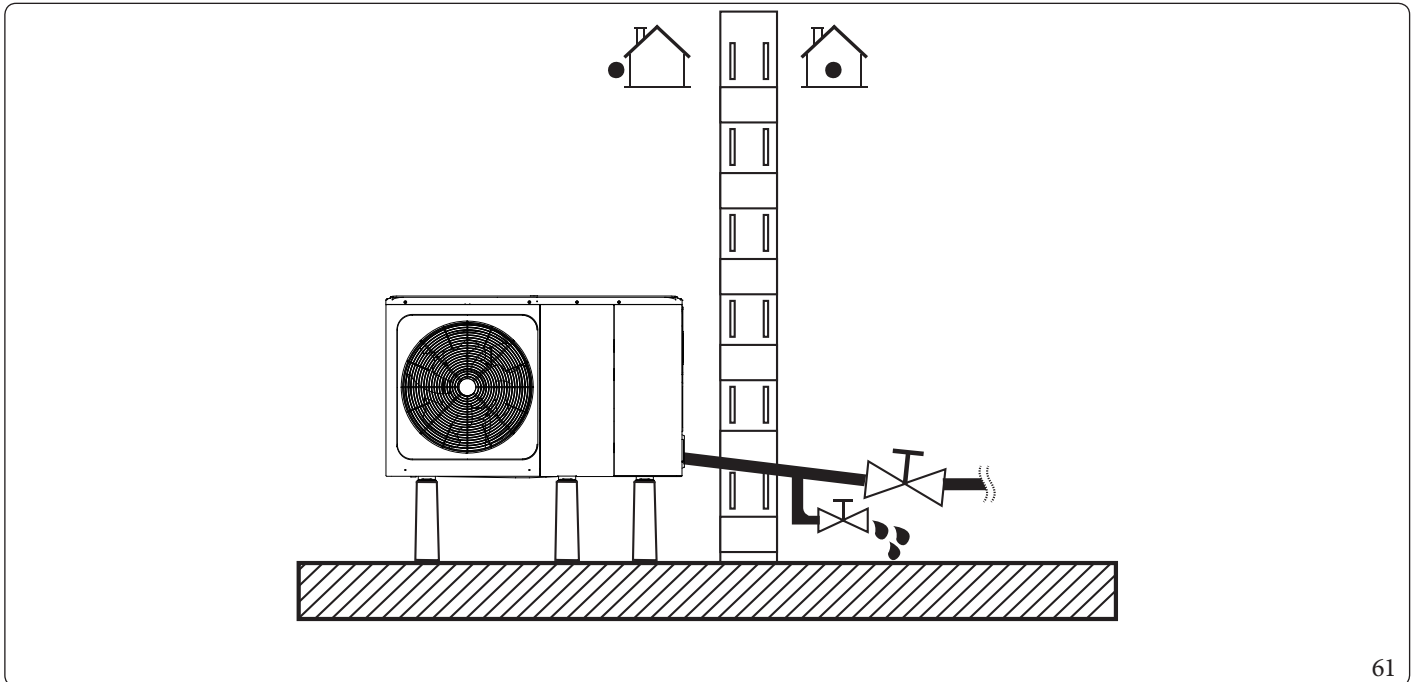

61



If water is not removed from the system under frozen conditions with the unit idle, the frozen water could damage parts of the hydraulic circuit.

### Check the water circuit.

The units are fitted with a water inlet and outlet for connection to a water circuit.

The units must only be connected to closed water circuits. Connection to an open water circuit could cause excessive corrosion to the water pipes. Only materials compliant with current laws must be used.

Before going on with installation of the units, check the following:

- Maximum water pressure  $\leq 3$  bar.
- Maximum water temperature  $\leq 70^{\circ}\text{C}$  depending on the setting of the safety device.
- Always use materials that are compatible with the water used in the system and with the materials used in the unit.
- Make sure that the components installed in the on-field pipes can withstand the water temperature and pressure.
- The drain valves must all be installed in the low points of the system to completely drain the circuit during maintenance.
- All the high points of the system must be fitted with vents. The vents must be located in easily accessible points to perform service operations. There is an automatic air purge valve inside the unit. Check that this air purge valve is not tight so that air may be automatically relieved from the water circuit.

## Water volume and dimensioning of the expansion vessels.

### • Models 4-16kW.

The units are equipped with an 8L expansion vessel with a default pre-pressure of 1 bar. The pre-pressure of the expansion vessel might need to be adjusted to guarantee proper operation of the unit.

1) Check that the total water volume of the system always available and not shut off, excluding the internal water volume of the unit, is at least 40L. See Chap. 14 “Technical specifications.” to find the total internal water volume of the unit.



- In the majority of applications, this minimum water volume will be satisfactory.
- However in critical processes or in environments with a high thermal load, additional water could be necessary.
- When the circulation in each space heating circuit is controlled by remote control valves, this minimum water volume needs to be maintained even if all the valves are closed.

2) The volume of the expansion vessel must be adjusted to the total volume of the water system.

3) Dimension the expansion for the heating and cooling circuit.

The volume of the expansion vessel can follow the figure below:

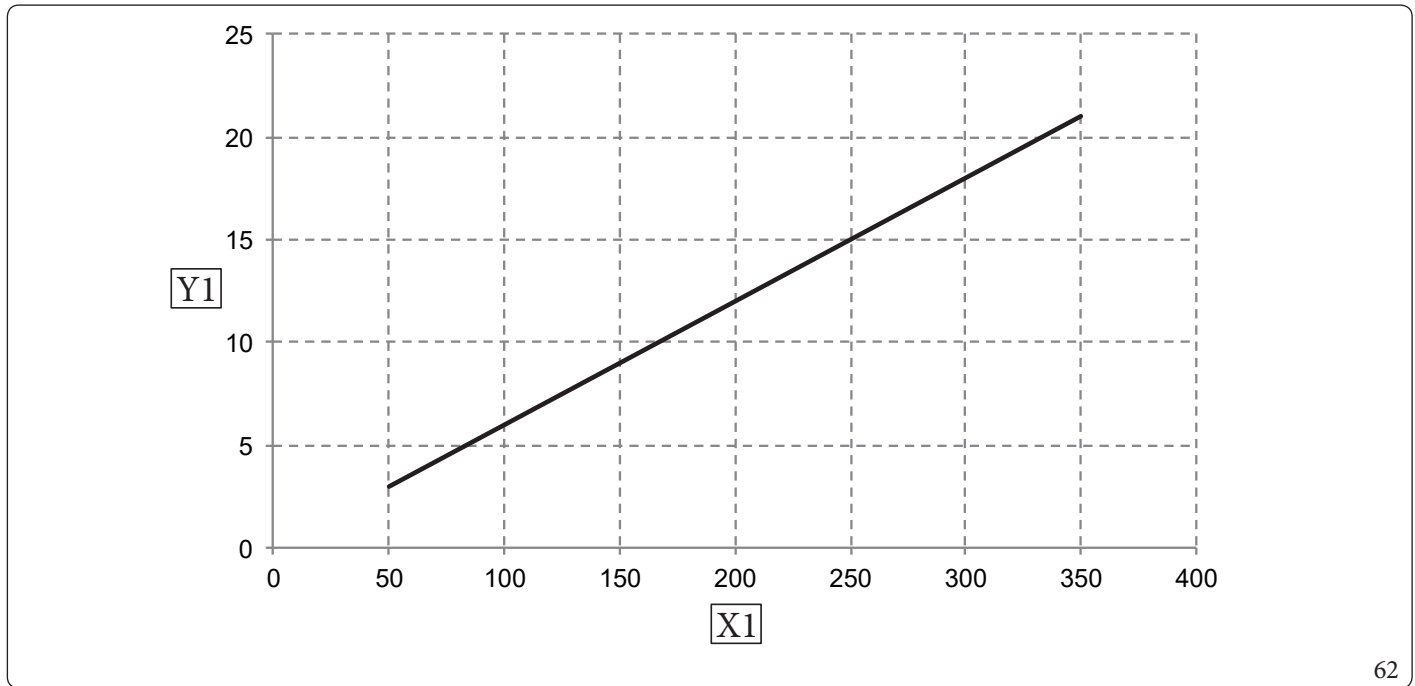

Key (Fig. 62):

X1 - Volume of system water (L)

Y1 - Expansion vessel (L)

### Water circuit connection.

The water connections must be performed properly according to the labels applied on the heat pump, indicating water inlet and outlet.



Be careful not to deform the unit's pipes by exerting excessive force when connecting the pipes. Pipe deformations can cause the unit to malfunction.

Always keep the following in mind when connecting the water circuit:

- Use a proper thread sealant to seal the connections. The seal must be capable of withstanding the pressures and temperatures of the system.
- When non-copper metal pipes are used, make sure the two materials are insulated from each other to avoid galvanic corrosion.

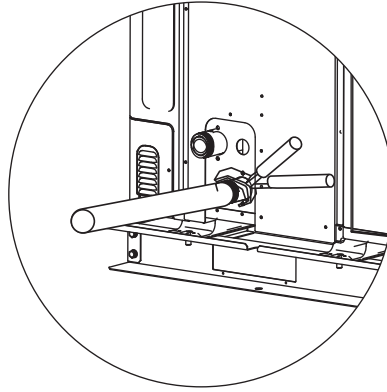

63



The unit must be used in a closed water system only. The application in an open water circuit could cause excessive corrosion to the water pipes:

- Never use any galvanised parts in the water circuit. These parts can corrode excessively as the copper pipes are used in the internal water circuit of the unit
- When a 3-way valve or 2-way valve is used in the water circuit. The maximum recommended switching time of the valve should be less than 60 seconds.

### Anti-freeze protection of water circuit.

All the internal hydronic parts are insulated to reduce thermal dispersion. Insulation must also be added to the pipes on the field. The software has special functions that use the heat pump to protect the entire system from freezing. When the water flow temperature in the system drops below a certain value, the unit heats the water with the heat pump. The anti-freeze protection function only deactivates when the temperature rises to a certain value.

In case of a power failure, the above features would not protect the unit from freezing. It is therefore recommended to empty the system (if the water is not mixed with glycol). If the system remains idle, empty it and disassemble and clean the flow switch to prevent the water inside from freezing. The flow switch must be removed and dried, and then refitted in the unit.

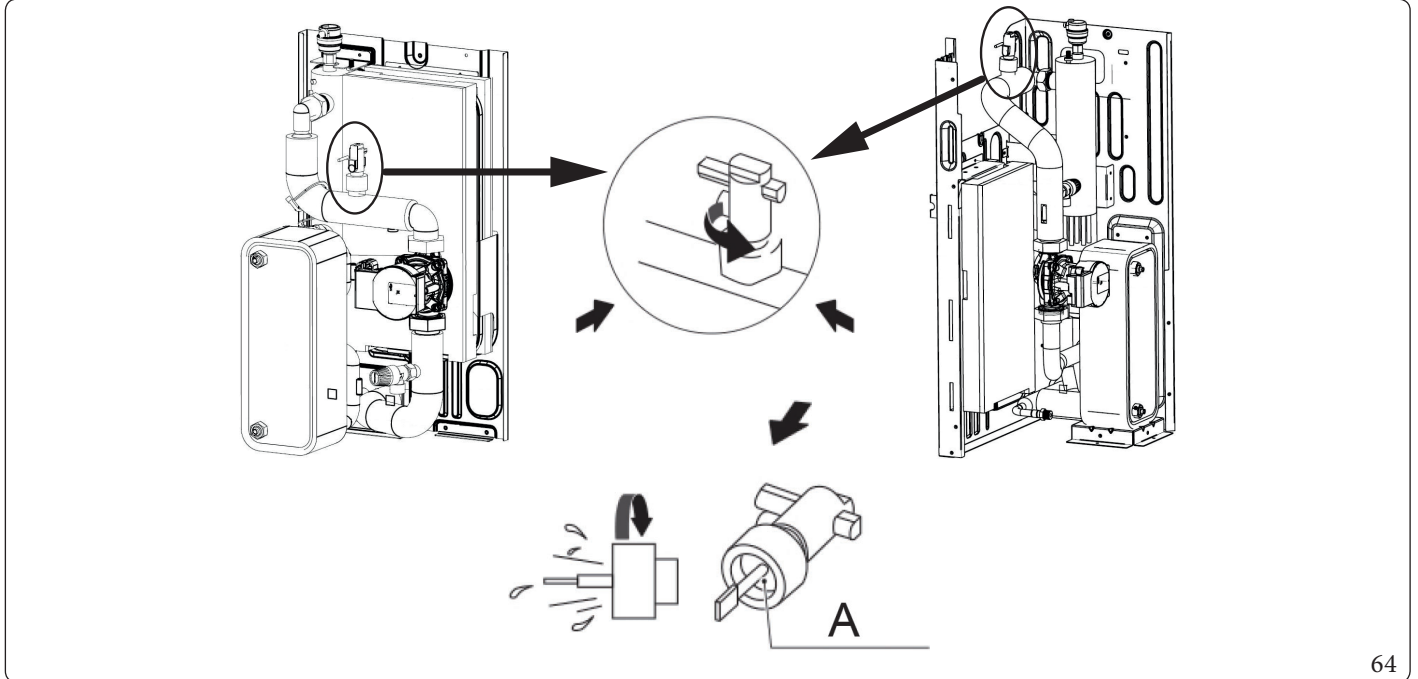

Key (Fig. 64):

A - Keep dry.

“Anti-clockwise rotation, remove the flow switch. Dry the flow switch completely.”



When the unit remains idle for a long time, make sure it remains on. If you want to cut power, the water should be completely drained from the system to prevent the unit and pipes from being damaged by freezing. Furthermore, power must be cut from the unit after the system has been emptied.



**Ethylene glycol and polypropylene glycol are TOXIC.**

## 9.5 FILLING WITH WATER.

- Connect the water feed to the filling valve and open the valve.
- Make sure that the automatic air purge valve is open (at least 2 turns).
- Fill with water at a pressure of approximately 2.0 bar. Remove as much air in the circuit as possible by using the air purge valves.

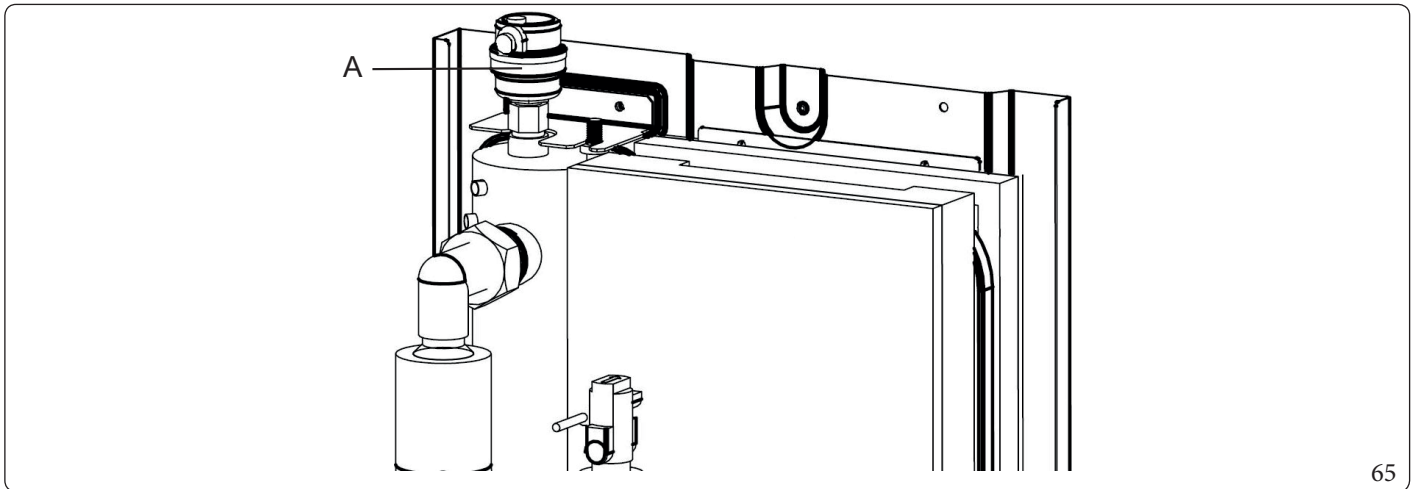

65

Key (Fig. 65):

- A - To deaerate the system, remove the black rubber cap and open the air purge valve, turn anti-clockwise at least 2 complete turns to release air from the system. When the de-aeration operation is over, put the black plastic cap back on, paying attention to position the vent valve near the slit in the cap.



It might not be possible to remove all the air in the system while filling. The remaining air will be removed by means of the automatic air purge valves during the initial hours of operation of the system. It could be necessary to top up water afterwards.

- The water pressure varies depending on the water temperature (the higher the temperature the higher the pressure). Nonetheless, water pressure must always remain below 0.3 bar to prevent air from entering the circuit.
- The unit might discharge too much water through the safety valve.
- The quality of the water must comply with directives EN 98/83 EC.
- Details on the water quality conditions are found in directives EN 98/83 EC.

## 9.6 WATER PIPE INSULATION.

The entire water circuit, including all of water pipes, must be insulated to prevent condensate from forming in cooling mode and the reduction of heating and cooling capacity, as well as to prevent the outside water pipes from freezing during winter. The insulation material must have a fire resistance of at least B1 and must comply with all standards in force. The sealing materials must be at least 13 mm thick with thermal conductivity 0.039 W/mK to prevent outside water pipes from freezing.

If the outdoor temperature is above 30° C and 80% RH respectively, the thickness of the sealing materials shall be at least 20 mm to prevent any condensate build-up on the gasket surface.

## 9.7 WIRING ON FIELD.



**A main switch or another disconnection device, with separation of contacts in all poles, must be incorporated in the fixed wiring in compliance with local laws and standards. Switch of power before performing any connection. Only use copper cables. Never clamp the cables in bundles and make sure they do not come into contact with pipes and sharp corners. Make sure no external pressure is applied to the connections of the terminals. All the cables and components on the field must be installed by an authorised electrician and must comply with local laws and standards.**

**On-field wiring must be carried out according to the wiring diagram supplied with the unit and in compliance with the following instructions.**

**Make sure to use a dedicated power supply. Never use a power supply shared by another device. Check that there is an earthing connection. Do not earth the unit to a service pipe, to a surge protective device or to earthing of the telephone line. Incomplete earthing can cause electric shocks.**

**Make sure to install an earth fault circuit switch (30 mA). Otherwise electrical shocks could occur.**

**Make sure to install the required fuses or circuit breakers.**

### Precautions for wiring jobs.

- Secure the cables so that they do not come into contact with the pipes (especially on the high-pressure side).
- Secure the wiring with cable clamps to prevent them from coming into contact with the pipes, especially on the high-pressure side.
- Make sure no external pressure is applied to the connectors of the terminals.
- When the earth fault circuit switch is installed, make sure that it is compatible with the inverter (resistant to high-frequency electric disturbances) to avoid needless opening of the earth fault circuit switch.



The earth leakage circuit breaker must be a high-speed switch of 30 mA (<0.1 s).

- This unit is fitted with an inverter. The installation of a shunt capacitor not only reduces the improvement effect of the power factor, but can all also cause anomalous heating of the capacitor due to high-frequency waves. Never install a shunt capacitor as it could cause accidents.

## Wiring overview.

- **Models 4-16kW.**

The illustration below provides an overview of the field wiring required between the different parts of the system.

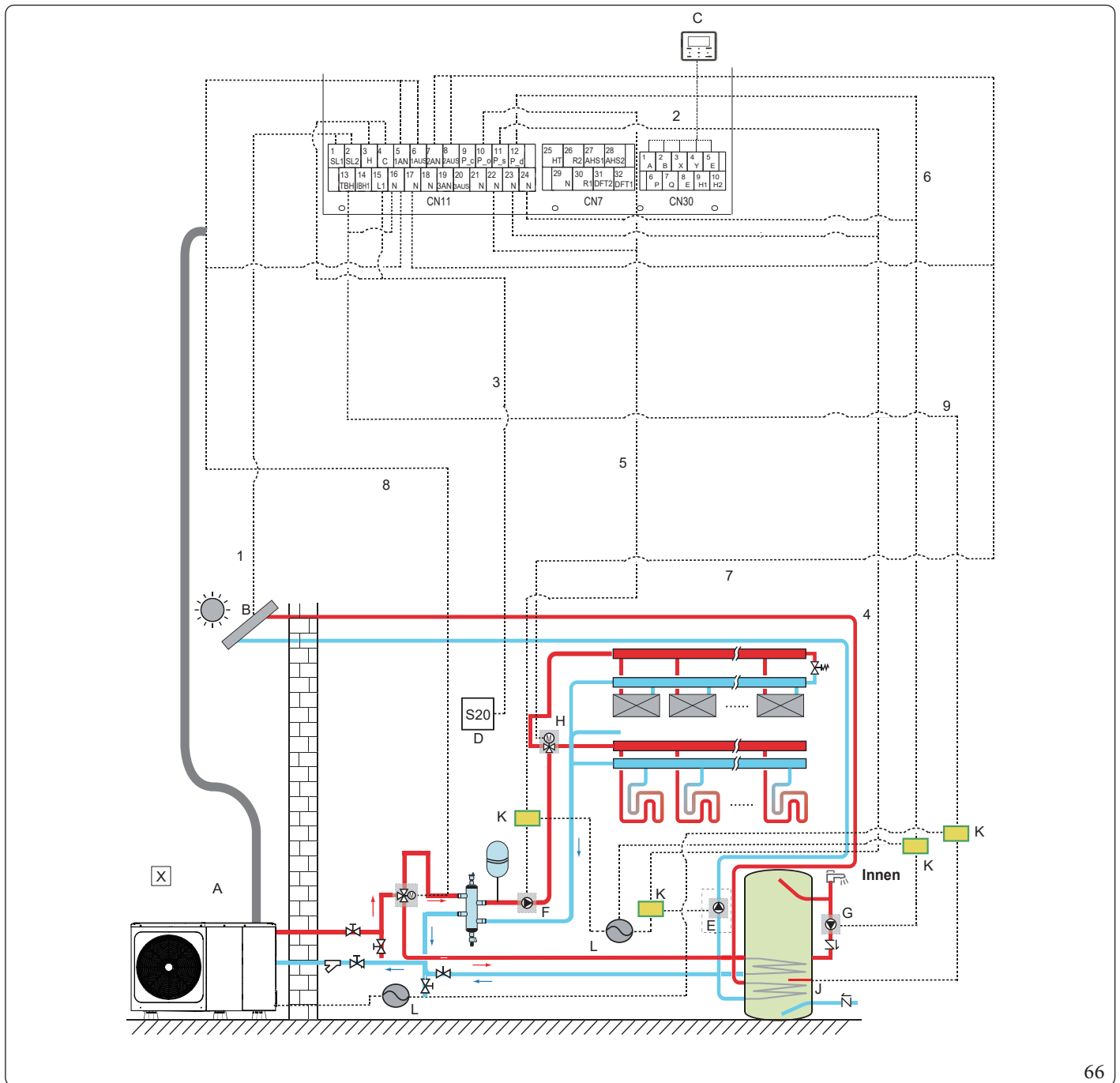

66

Pos.	Assembly unit	Pos.	Assembly unit
A	Heat pump	H	SV2: Summer/Winter 3-way valve
B	Solar collector	I	SV1: 3-way valve for DHW tank
C	Control panel	J	TBH: ACS storage tank heater
D	High-voltage room thermostat	K	Contactors
E	P_s: solar pump	L	Electric power supply
F	P_o: Zone 1 circulation pump	X	Outdoor
G	P_d: DHW recirculation pump		



Pos.	Description	AC/DC	Number of conductors required	Maximum operating current
1	Signal cable for thermal solar station activation	AC	2	200 mA
2	Control panel cable	AC	5	200 mA
3	Room thermostat cable	AC	2	200 mA (a)
4	Solar pump control cable	AC	2	200 mA (a)
5	Zone 1 circulation pump control cable	AC	2	200 mA (a)
6	DHW circulation pump control cable	AC	2	200 mA (a)
7	SV2: 3-way valve control cable	AC	3	200 mA (a)
8	SV1: 3-way valve control cable	AC	3	200 mA (a)
9	Control cable for tank booster heater (TBH)	AC	2	200 mA (a)

(a): Minimum cable cross-section AWG18 (0.75 mm<sup>2</sup>)



Please use H07RN-F for the power cable. All the cables are connected in high-voltage except for the probe cable and the control panel cable.

- The instruments must be earthed.
- All external high voltage loads, if in metal or with earthing connection, must be earthed.
- All external load currents must be lower than 0.2A, if the single load current is higher than 0.2A, the load must be controlled by an AC contactor.
- The ports of the wiring terminals R1, R2, and DFT1, DFT2 only supply a signal switch. Please refer to Chap. 9.7 "Connection for other components." to get the position of the ports in the unit.

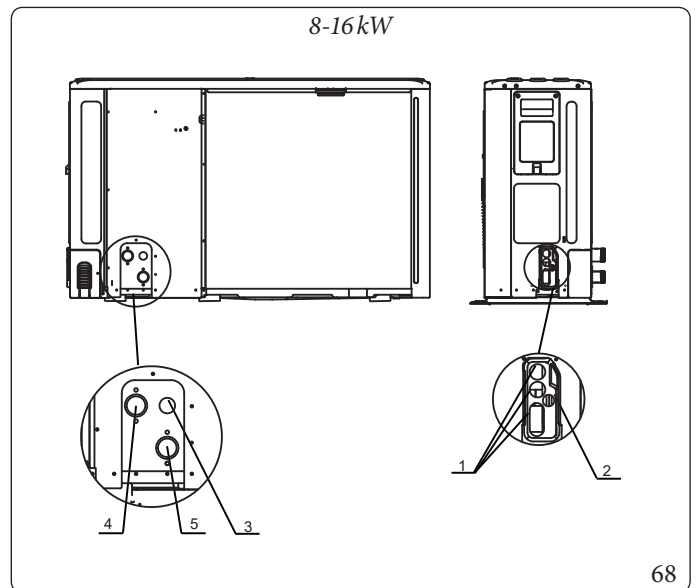
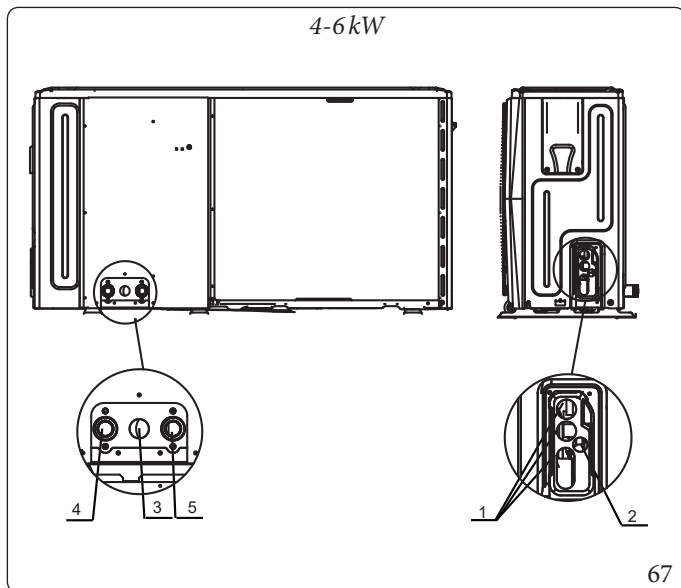

Pos.	Assembly unit
1	Hole for high-voltage cable
2	Hole for low-voltage cable
3	Drain pipe hole
4	Water outlet
5	Water inlet

### Precautions for electric power wiring.

When connecting the power terminal, use the ring cable lug with insulation enclosure (See Figure 69).

Use a power cable compliant with specifications and firmly connect the power cable. Make sure the cable is firmly secured so that it is not yanked off by an outside force.

If it is not possible to use the ring cable lug with insulation enclosure, make sure:

- Not to connect two power cables with different diameters to the same power terminal (causing the wires to overheat due to loose wiring) (See figure 70).

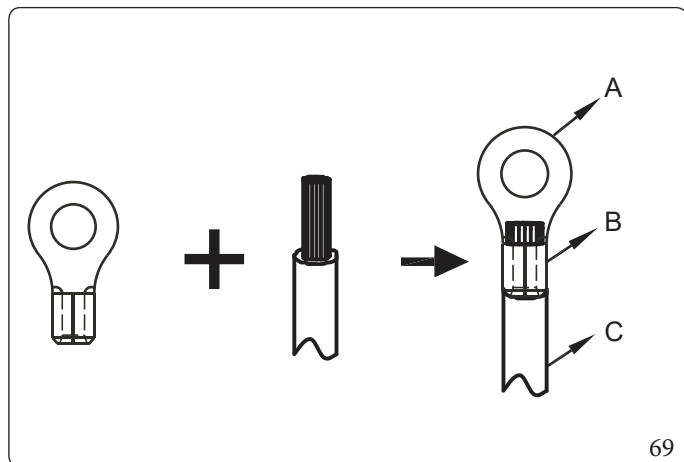

Key (Fig. 69):

- A - Ring cable lug
- B - Insulation tube
- C - Power cable

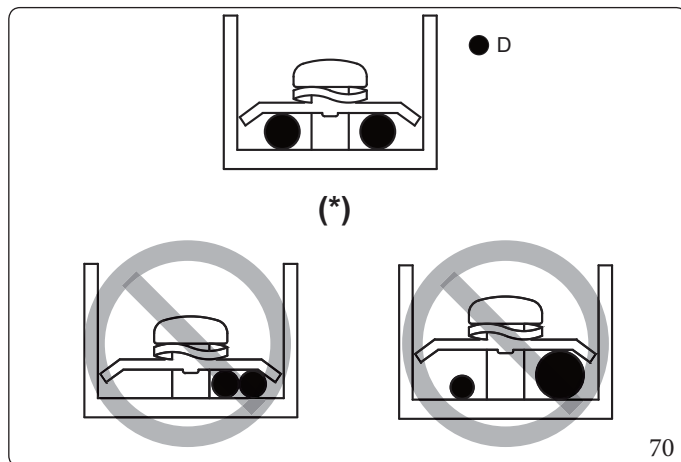

Key (Fig. 70):

- D - Copper cable
- (\*) - Correct power supply connections

- Use the correct screwdriver to tighten the terminal screws. Small screwdrivers could damage the screw head and prevent them from being properly tightened.
- Overtightening the terminal screws could damage them.
- Connect an earth leakage circuit breaker and a fuse to the power line.
- In the wiring, make sure that the required wires are used, perform the complete connections and secure the wires so that no external force can affect the terminals.

### Safety device requirements.

1. Select the cable diameters (minimum value) individually for each unit based on the table. If the rated current exceeds 63A, the diameters of the wires must be selected based on national regulations on wiring.
2. The maximum admissible variation of the phase to phase voltage range is 2%.
3. Select the circuit breaker with separation of contacts in all poles no lower than 3 mm to allow complete disconnection.

Rated current of the appliance (A)	Rated cross section area (mm <sup>2</sup> )	
	Flexible cables	Cable for fixed wiring
≤3	0.5 and 0.75	1 and 2.5
>3 and ≤6	0.75 and 1	1 and 2.5
>6 and ≤10	1 and 1.5	1 and 2.5
>10 and ≤16	1.5 and 2.5	1.5 and 4
>16 and ≤25	2.5 and 4	2.5 and 6
>25 and ≤32	4 and 6	4 and 10
>32 and ≤50	6 and 10	6 and 16
>50 and ≤63	10 and 16	10 and 25

**Remove the cover of the main compartment.**

Unit	4kW	6kW	8kW	12kW T	14kW T	16kW T
Maximum overcurrent protection (MOP)	31	31	32	27	27	27
Maximum fuse amp.(A) (MFA)	32	32	32	32	32	32
Cable dimension (mm <sup>2</sup> )	6,0	6,0	8,0	4,0	4,0	4,0

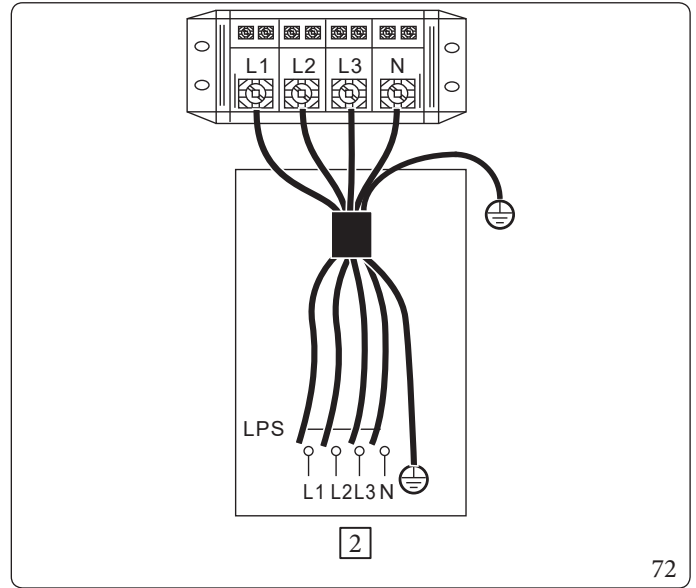
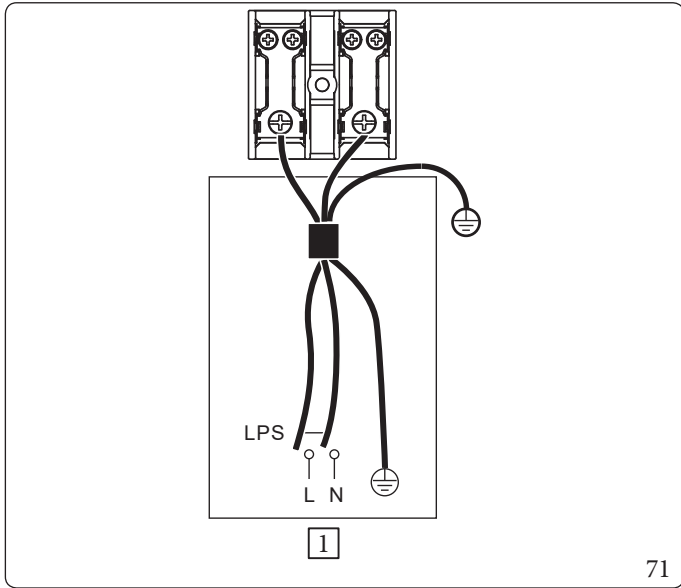

The earth leakage circuit breaker must be high-speed type A - 30 mA (<0.1 s).  
The declared values are the maximum values (cf. electrical data for the exact values).

Key (Fig. 71 - 72):

- 1 - Single phase unit power supply
- 2 - Three-phase unit power supply

Connection of power cable of the cascade system.

- Connection diagram of the electric control system of the cascade system (1N~)

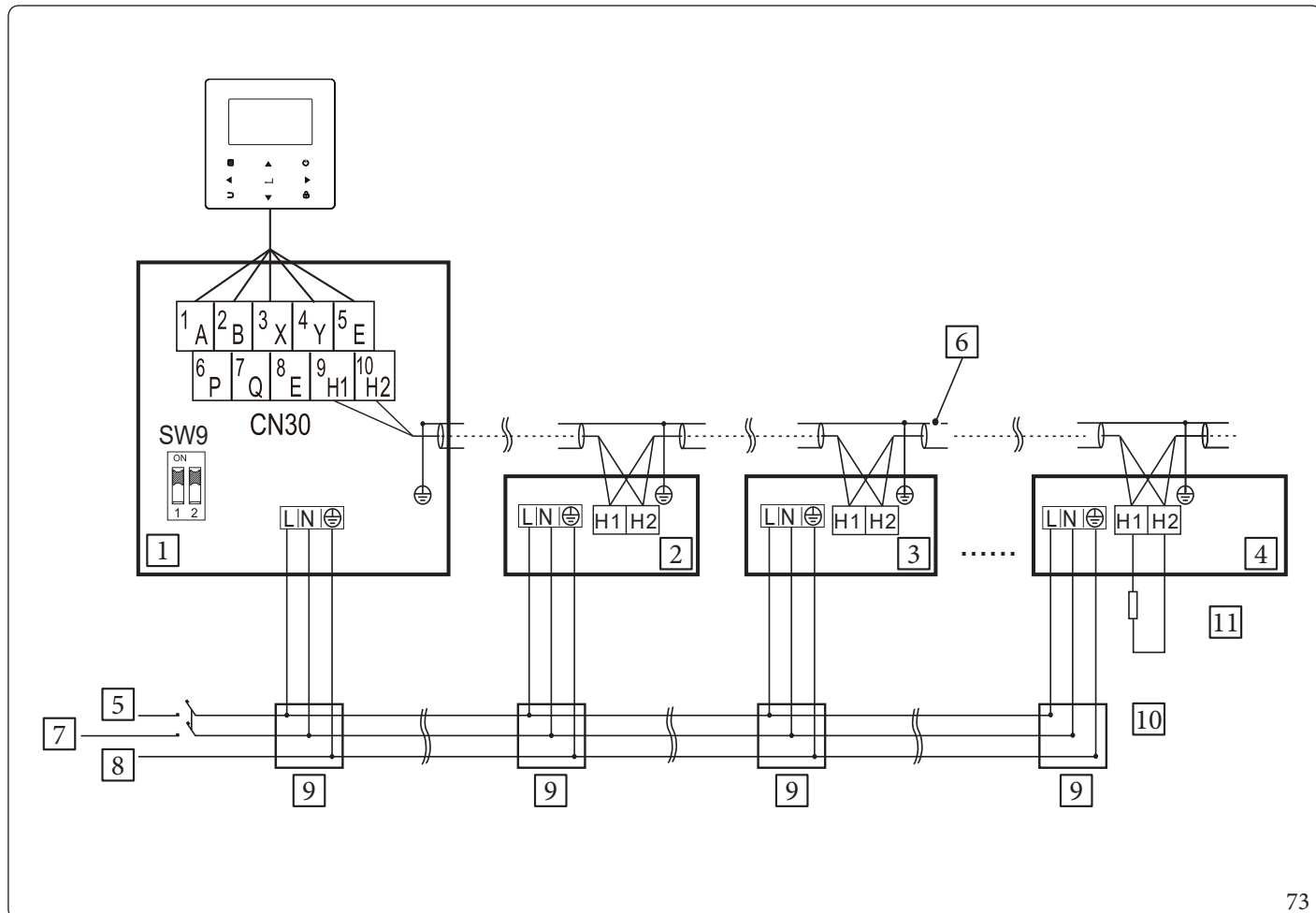

73

Key (Fig. 73):

- 1 - Master Unit
- 2 - Slave 1 unit
- 3 - Slave 2 unit
- 4 - Slave X unit
- 5 - On/Off Switch
- 6 - Please use the screened wire, and the screening layer must be earthed.
- 7 - Inside
- 8 - Powers supply
- 9 - Distribution board
- 10 - External resistance (network adapter)
- 11 - Only the last unit requires the addition of the terminal resistance between H1 and H2.

SW9		
	ON	Master Unit
	OFF	Slave unit

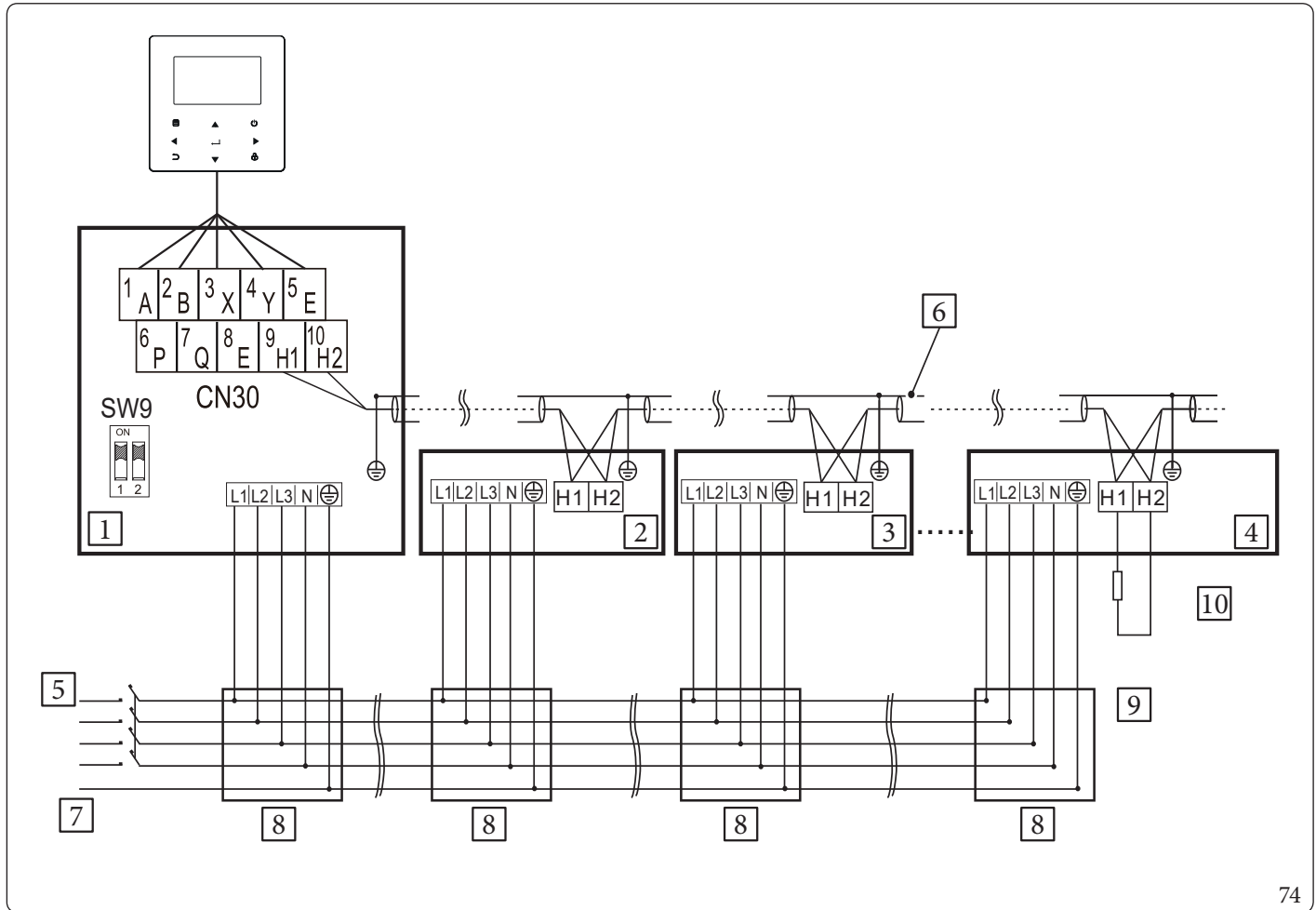

• Connection diagram of the electric control system of the cascade system (3N~)



74

Key (Fig. 74):

- 1 - Master Unit
- 2 - Slave 1 unit
- 3 - Slave 2 unit
- 4 - Slave X unit
- 5 - On/Off Switch
- 6 - Please use the screened wire, and the screening layer must be earthed.
- 7 - Power supply
- 8 - Distribution board
- 9 - External resistance (network adapter)
- 10 - Only the last unit requires the addition of the terminal resistance between H1 and H2.

SW9		
	ON	Master Unit
	OFF	Slave unit



- The cascade function of the system supports up to 6 machines.
- To guarantee the success of automatic addressing, other the machines must be connected to the same power supply and powered evenly.
- Only the Master unit can be connected to the control panel. SW9 of the Master unit must be switched "on". The slave unit cannot be connected to the control panel.
- Please use the screened cable, and the screening must be earthed.

Connection for other components.

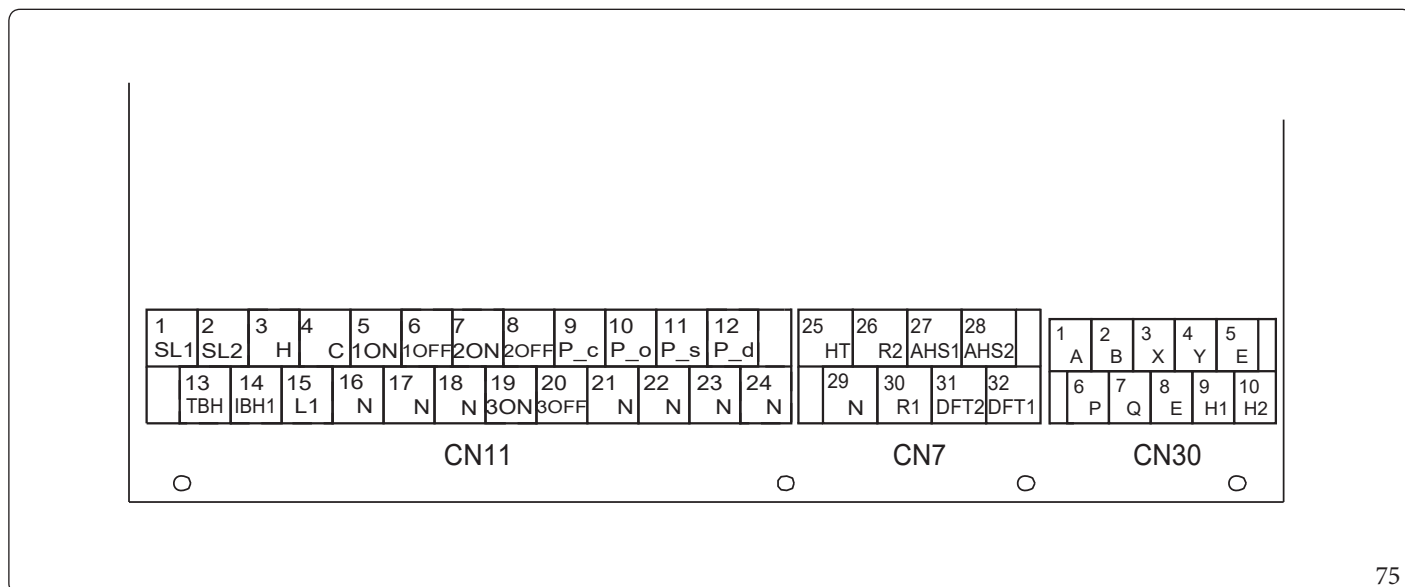

75

	Code	Print	Connection to
CN11	①	1	SL1
		2	SL2
	②	3	H
		4	C
		15	L1
	③	5	1ON
		6	1OFF
		16	N
	④	7	2ON
		8	2OFF
		17	N
	⑤	9	P_c
		21	N
	⑥	10	P_o
		22	N
	⑦	11	P_s
		23	N
	⑧	12	P_d
		24	N
	⑨	13	TBH
16		N	
⑩	14	IBH1	
	17	N	
⑪	18	N	
	19	3ON	
	20	3OFF	

	Code	Print	Connection to
CN30	①	1	A
		2	B
		3	X
		4	Y
		5	E
③	9	H1	
	10	H2	

	Code	Print	Connection to
CN7	①	26	R2
		30	R1
		31	DFT2
		32	DFT1
	③	27	AHS1
28		AHS2	

The board of the main hydraulic module supplies two types of control signal ports:

**Type 1:** Potential-free contact.

For example:

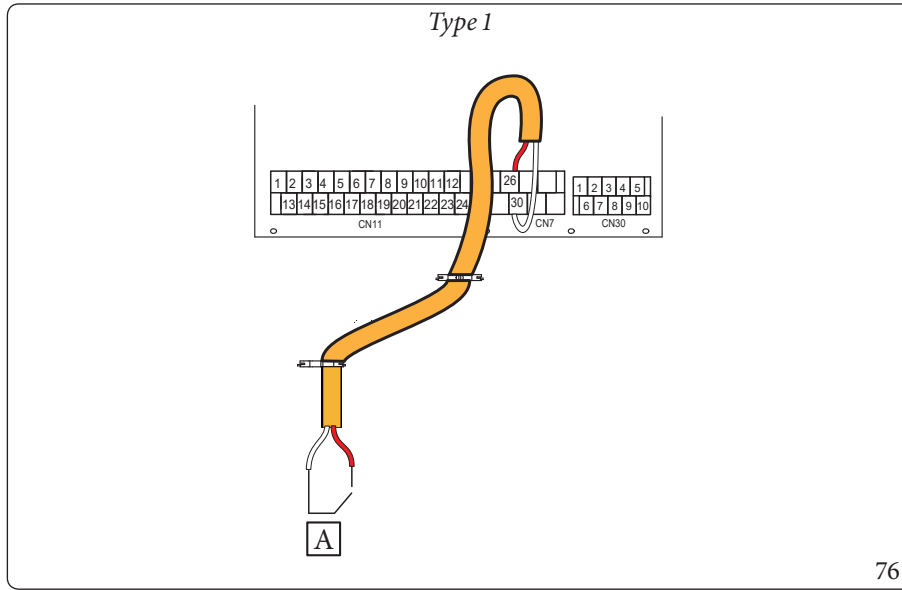

Key (Fig. 76):

A - Running

This example corresponds to the compressor running, with closed contact.

**Type 2:** The port supplies the signal with 220V voltage.

If the load current is  $< 0.2A$ , the load can be connected directly to the port.

If the load current is  $\geq 0.2A$ , an AC contactor must be connected for the load.

For example:

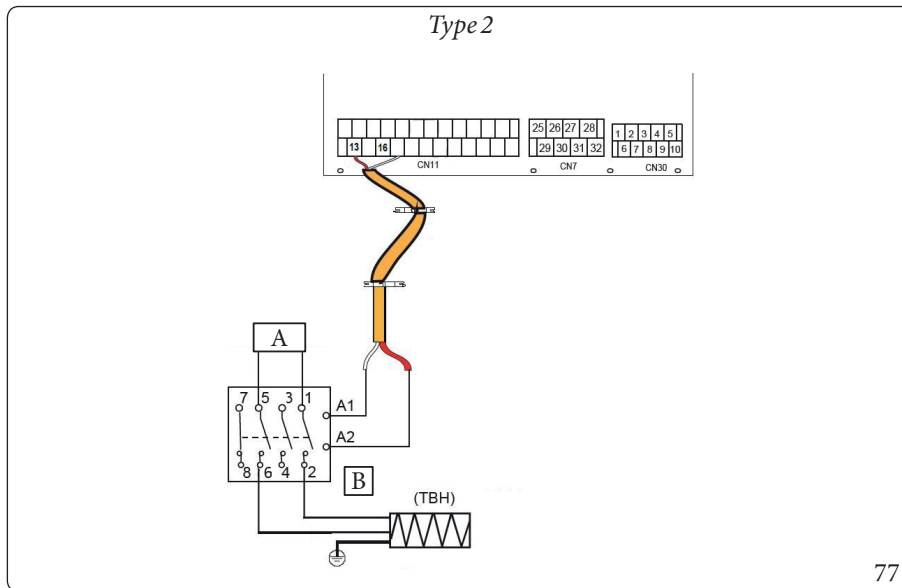

Legenda (Fig. 77):

A - Powersupply

B - Contactor

The connectors CN11/CN7 of the board of the main hydraulic module: the active solar station contact, the 3-way valves, the pumps, the tank booster heater, etc.

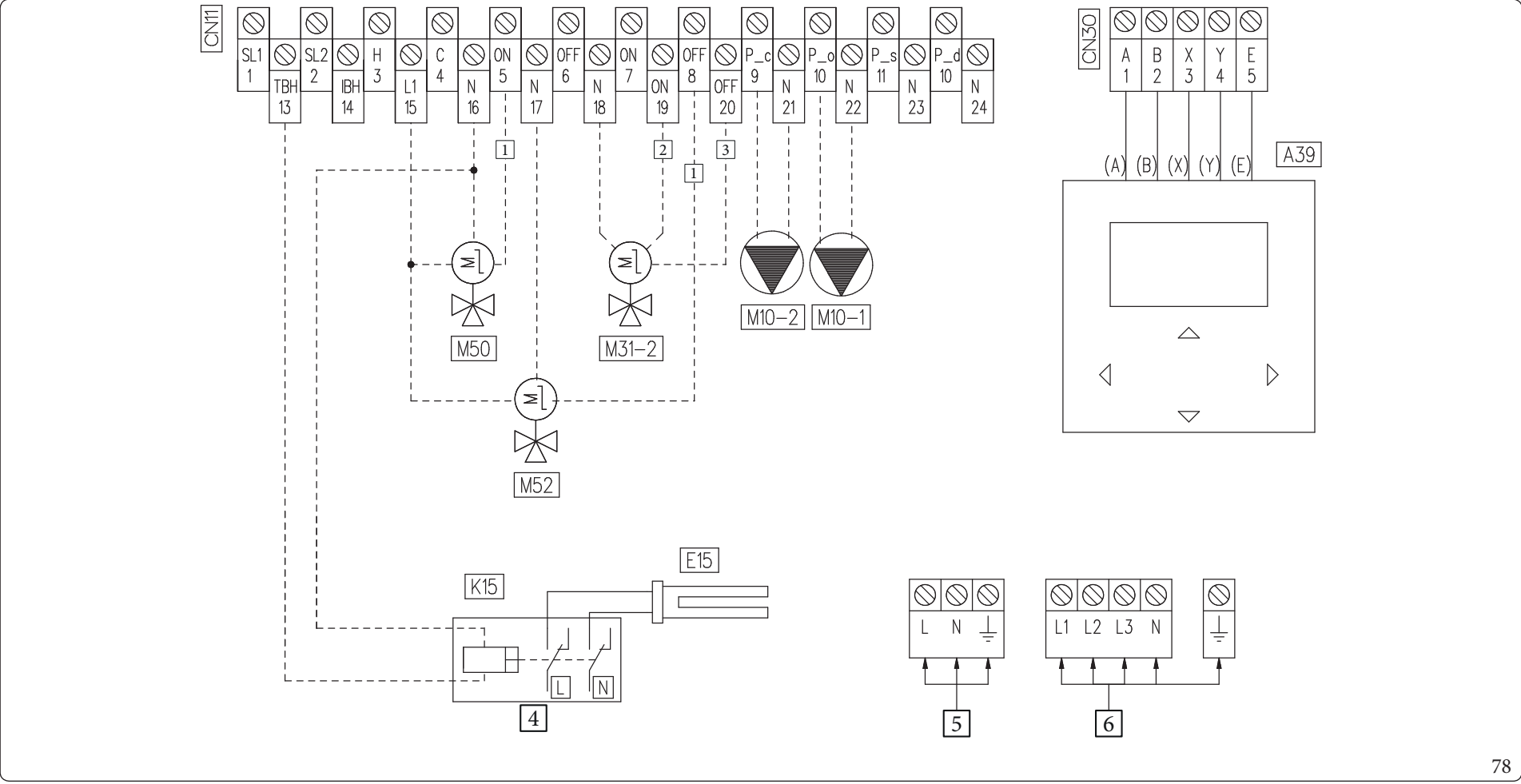

Key (Fig. 78):

- A39 - Control panel
- E15 - Domestic hot water integration resistance
- K15 - DHW booster heater relay
- M10-1 - Zone 1 circulator pump
- M10-2 - Zone 2 circulator pump
- M31-2 - Zone 2 mixing valve
- M50 - 3-way valve priority
- M52 - Summer/winter switch

- 1 - Open/Closed
- 2 - Open
- 3 - Closed
- 4 - Relay not supplied as optional
- 5 - 230 Vac 50Hz - Single-phase version
- 6 - 380 Vac 50Hz - Three-phase version

CN11-6	0V	DHW demand
	230V	System demand
CN11-8	0V	Winter (heating)
	230V	Summer (cooling)

**i** The following electrical connection diagram refers to the 3-way diverter valves (M50 and M52) supplied by Immergas being used as an optional kit.



## Vertical terminal boards connections diagram

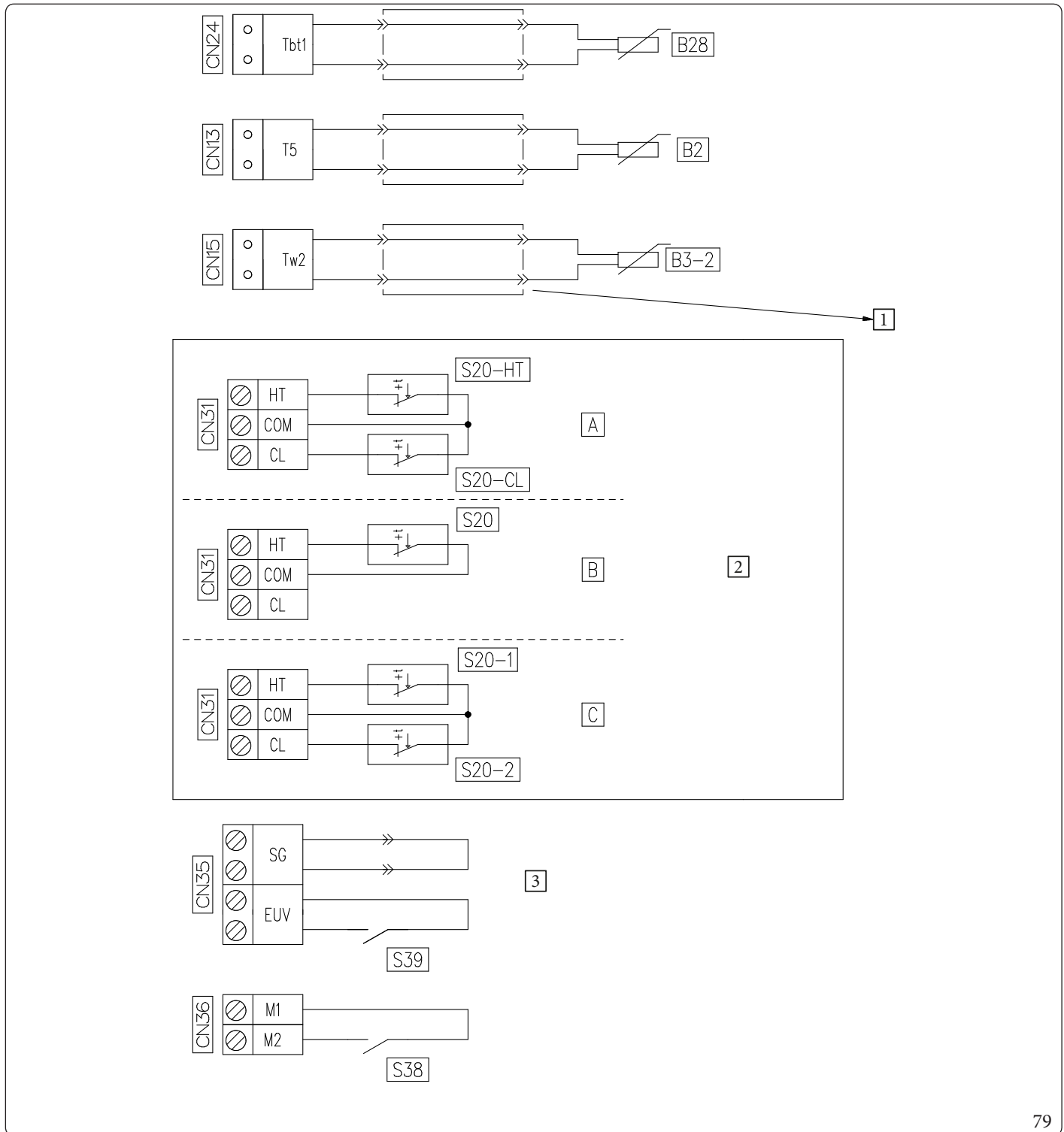

Key (Fig. 79):

- B2 - D.H.W. probe
- B3-2 - Zone 2 flow probe
- B28 - Inertial storage tank probe
- S20 - Room thermostat
- M20-1 - Zone 1 room thermostat
- S10-2 - Zone 2 room thermostat

- S20-HT - Room thermostat - heating
- S20-CL - Room thermostat - cooling
- S38 - Generator off selector
- S39 - Solar inlet

- 1 - Adapter wiring
- 2 - Thermostat contacts connection mode
- A - Central heating/cooling
- B - One zone
- C - Double zone
- 3 - To have the photovoltaic contact, apply the link on SG supplied as accessory.

The wiring of the components is illustrated below.

- Connect the cable to the appropriate terminals as shown in the figure.
- Secure the cable firmly.

4. For the 3-way valves SV1, SV2 and SV3:

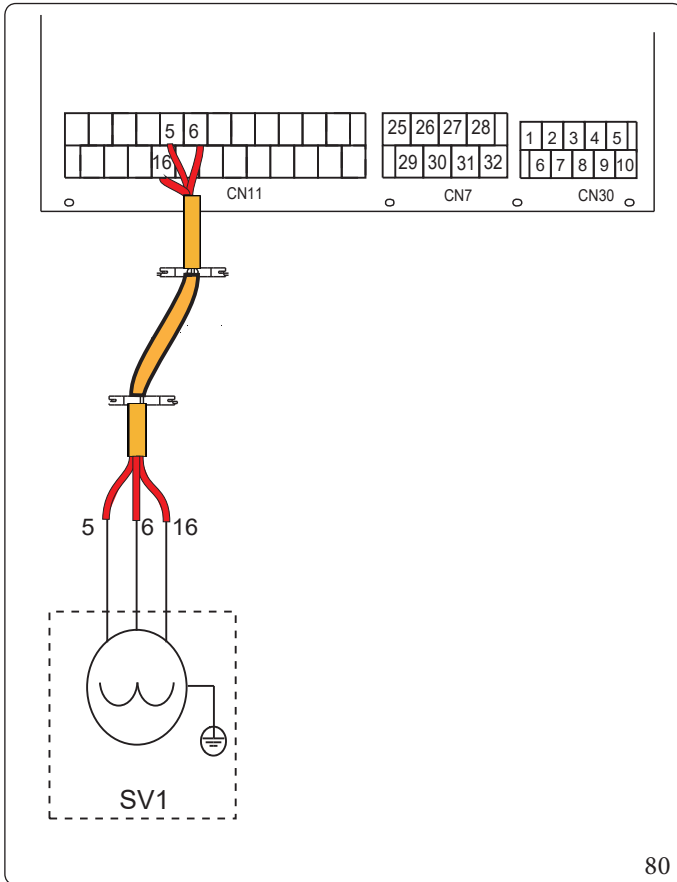

80

Voltage	220-240VAC
Maximum operating current (A)	0,2
Minimum wiring size (mm <sup>2</sup> )	0,75
Type of signal of control port	Type 2

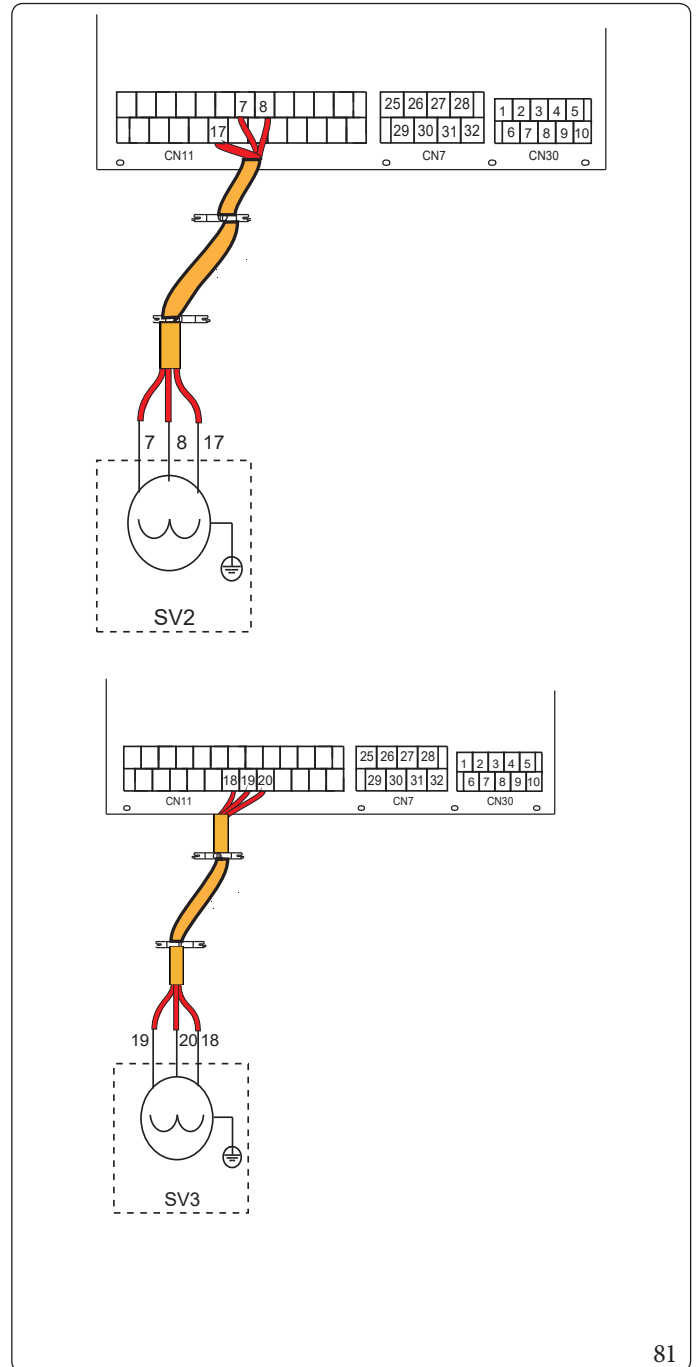

81

5. For Zone 1 pump (PUMP\_O):

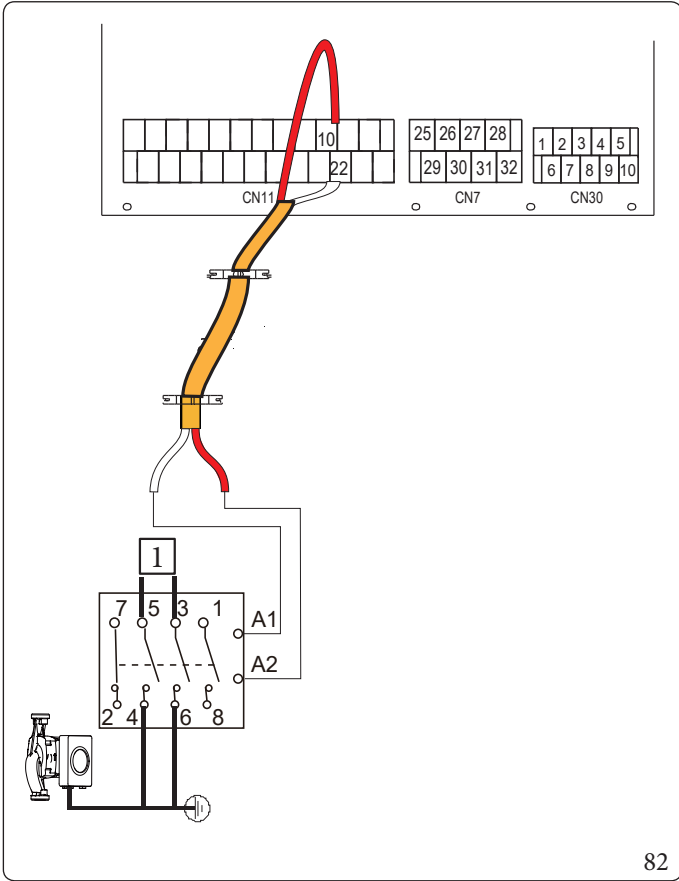

82

Key (Fig. 82):

1 - Power supply

Voltage	220-240VAC
Maximum operating current (A)	0,2
Minimum wiring size (mm <sup>2</sup> )	0,75
Type of signal of control port	Type 2

6. For Zone 2 pump (PUMP\_C):

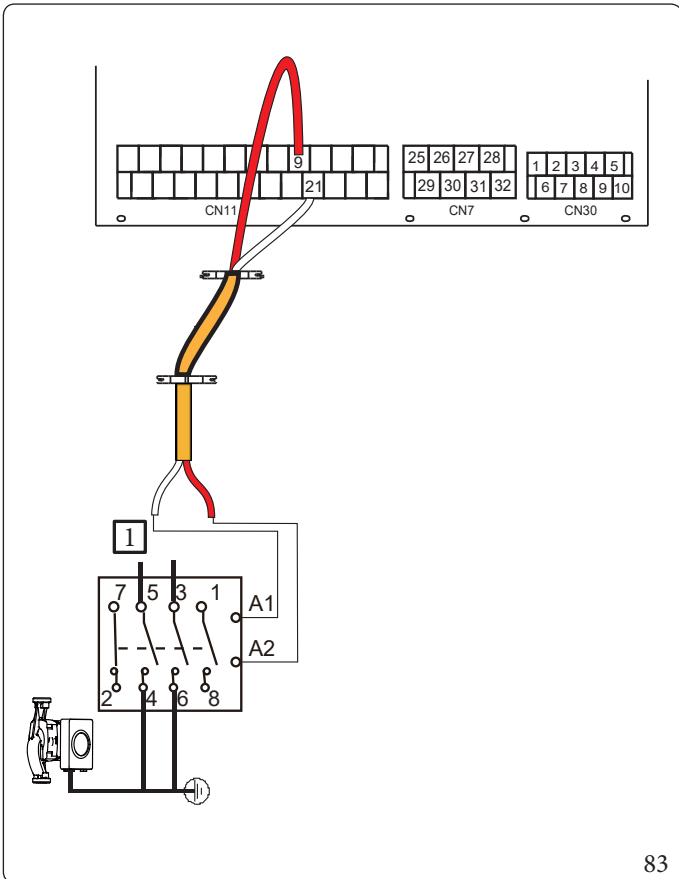

83

Key (Fig. 83):

1 - Power supply

Voltage	220-240VAC
Maximum operating current (A)	0,2
Minimum wiring size (mm <sup>2</sup> )	0,75
Type of signal of control port	Type 2

7. For DHW recirculation pump (PUMP\_D):

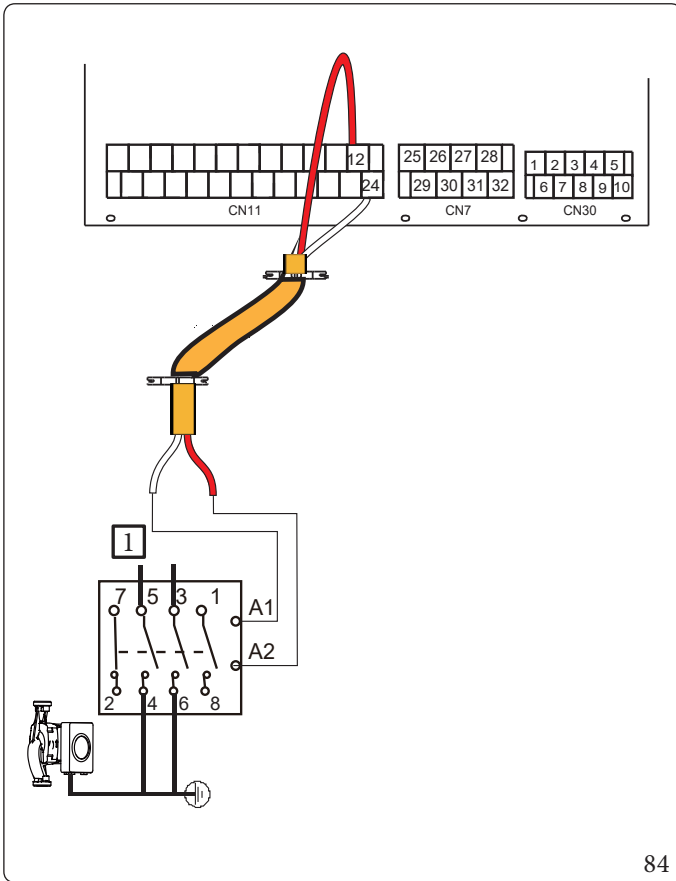

84

Key (Fig. 84):

1 - Powersupply

Voltage	220-240VAC
Maximum operating current (A)	0,2
Minimum wiring size (mm <sup>2</sup> )	0,75
Type of signal of control port	Type 2

8. For solar pump (PUMP\_S):

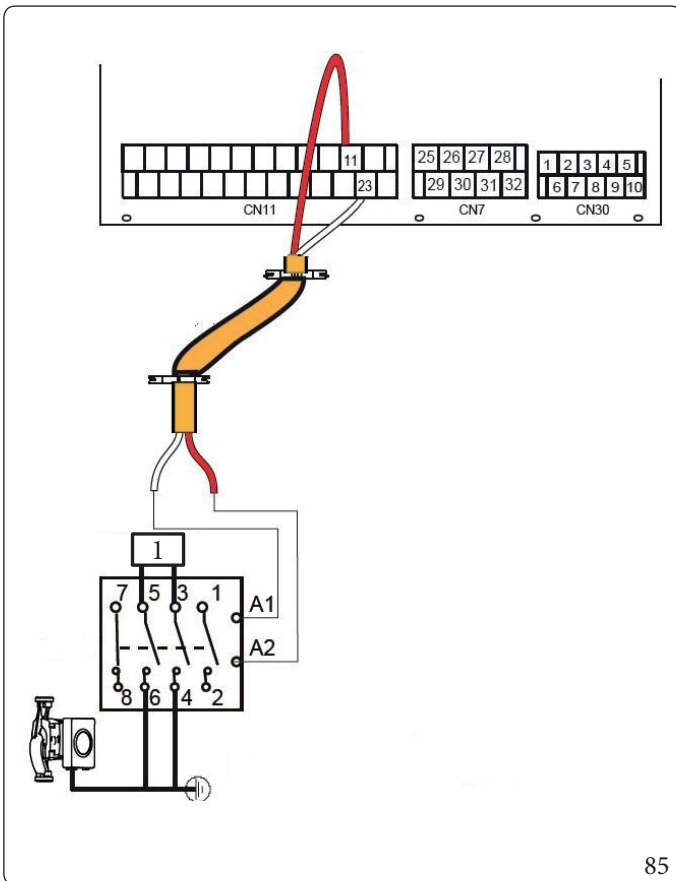

85

Key (Fig. 85):

1 - Powersupply

Voltage	220-240VAC
Maximum operating current (A)	0,2
Minimum wiring size (mm <sup>2</sup> )	0,75
Type of signal of control port	Type 2

9. For solar control unit contact:

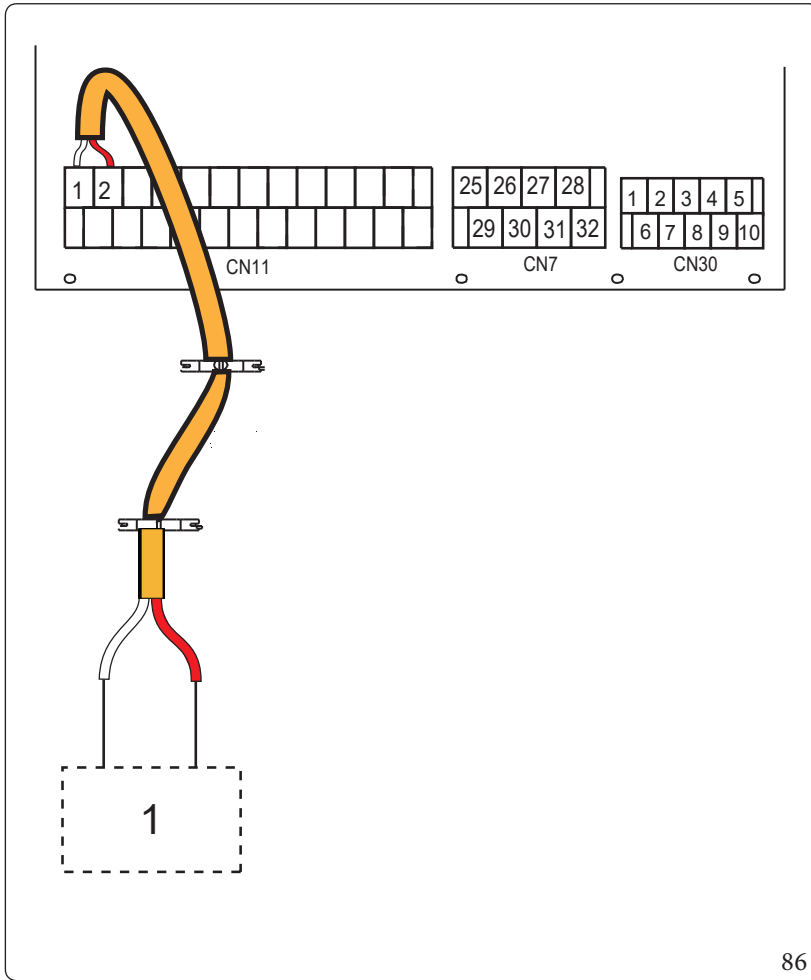

Legenda (Fig. 86):

1 - Connect to the solar control unit. Request active with 220-240V input.

Voltage	220-240VAC
Maximum operating current (A)	0,2
Minimum wiring size (mm <sup>2</sup> )	0,75

**10. For room thermostat:**

Room thermostat type 1 (High-voltage): "POWER SUPPLY INPUT" supplies the operating voltage to RT, does not directly supply voltage to the RT connector. The port "15 L1" supplies 220V voltage to the RT connector.

Room thermostat type 2 (Low-voltage): "POWER SUPPLY INPUT" supplies the working voltage to RT.



There are two optional connection methods that depend on the type of room thermostat.

**- Room thermostat type 1 (High-voltage):**

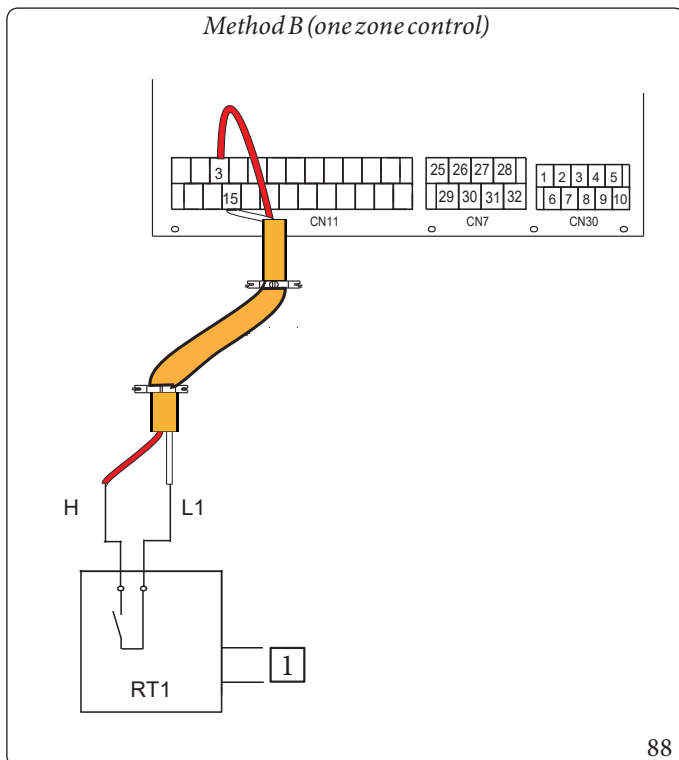
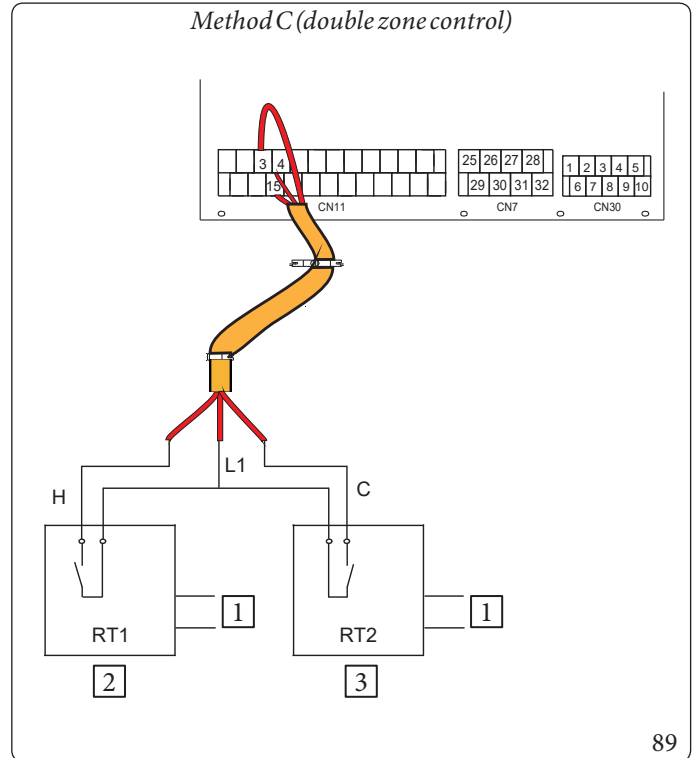
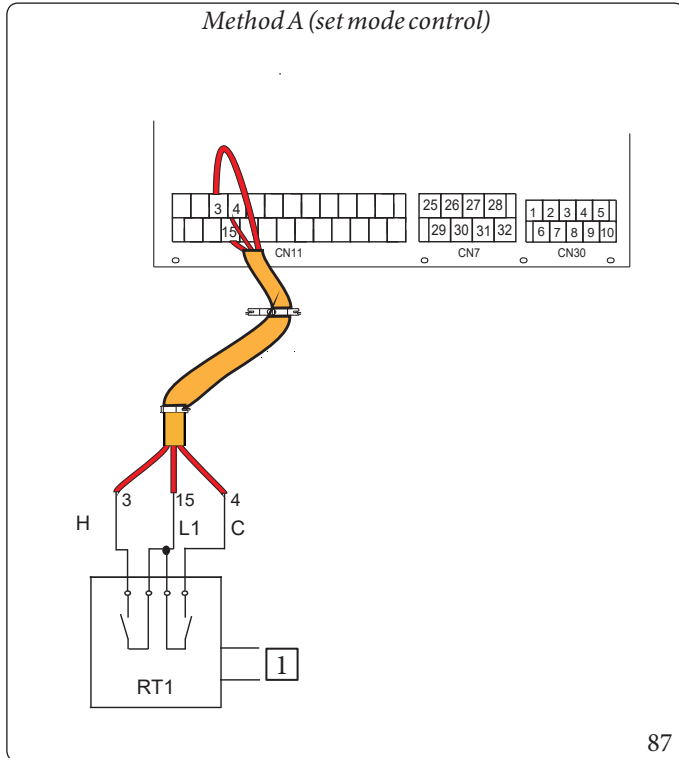

Legenda (Fig. 87 - 88 - 89):

- 1 - Powersupply input
- 2 - Zone 1
- 3 - Zone 2

Voltage	220-240VAC
Maximum operating current (A)	0,2
Minimum wiring size (mm <sup>2</sup> )	0,75

There are three methods to connect the thermostat cable (as described in the previous images) and it depends on the application.

- **METHOD A (Set mode control).**

RT can control heating and cooling individually, like the control panel for 4-pipe FCU.

When the hydraulic module is connected with the external temperature controller, on the control panel, in the "FOR SERVICEMAN" menu, set "6.1 ROOM THERMOSTAT" at "MODE SET":

- A.1 When the unit detects a 230VAC voltage between C and L1, the unit runs in cooling mode.
- A.2 When the unit detects a 230VAC voltage between H and L1, the unit runs in heating mode.
- A.3 When the unit detects a 0VAC voltage for both sides (C-L1, H-L1), the unit stops operating for space heating or cooling.
- A.4 When the unit detects a 230VAC voltage for both sides (C-L1, H-L1), the unit runs in cooling mode.

- **METHOD B (One zone control).**

RT supplies the switching signal to the unit. In the control panel, in the "FOR SERVICEMAN" menu set "6.1 ROOM THERMOSTAT" at "ONE ZONE":

- B.1 When the unit detects a 230VAC voltage between H and L1, the unit switches on.
- B.2 When the unit detects a 0VAC voltage between H and L1, the unit switches off.

- **METHOD C (Double zone control).**

The hydraulic module is connected with two room thermostats, on the control panel, in the "FOR SERVICEMAN" menu, set "6.1 ROOM THERMOSTAT" at "DOUBLE ZONE":

- C.1 When the unit detects a 230VAC voltage between H and L1, zone 1 switches on. When the unit detects a 0VAC voltage between H and L1, zone 1 switches off.
- C.2 When the unit detects a 230VAC voltage between C and L1, zone 2 switches on depending on the weather temperature curves. When the unit detects a 0VAC voltage between C and L1, zone 2 switches off.
- C.3 When H-L1 and C-L1 are detected as 0VAC, the unit switches off.
- C.4 When H-L1 and C-L1 are detected as 230VAC, both zone 1 and zone 2 switch on.

Room thermostat type 2 (Low-Voltage):

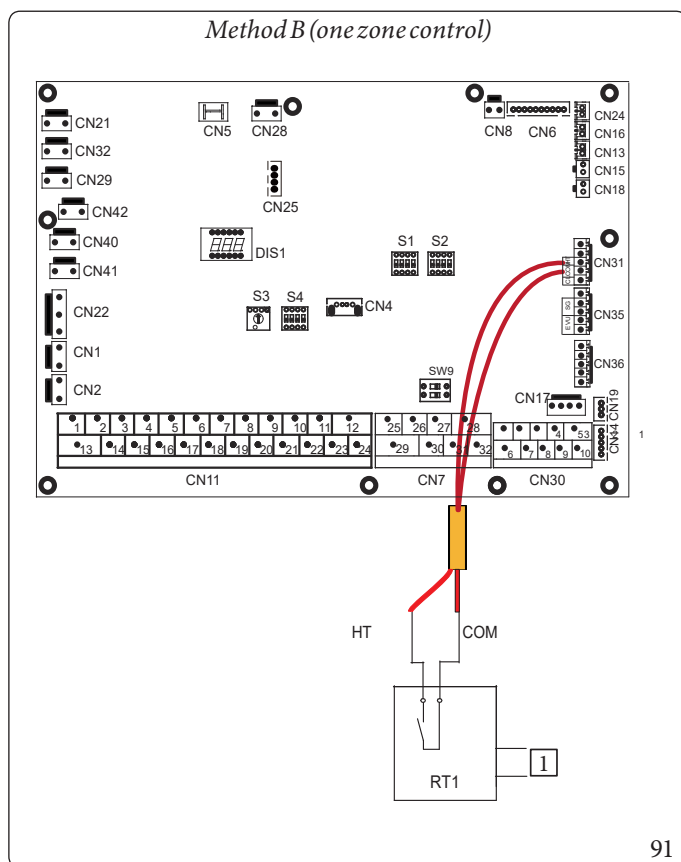
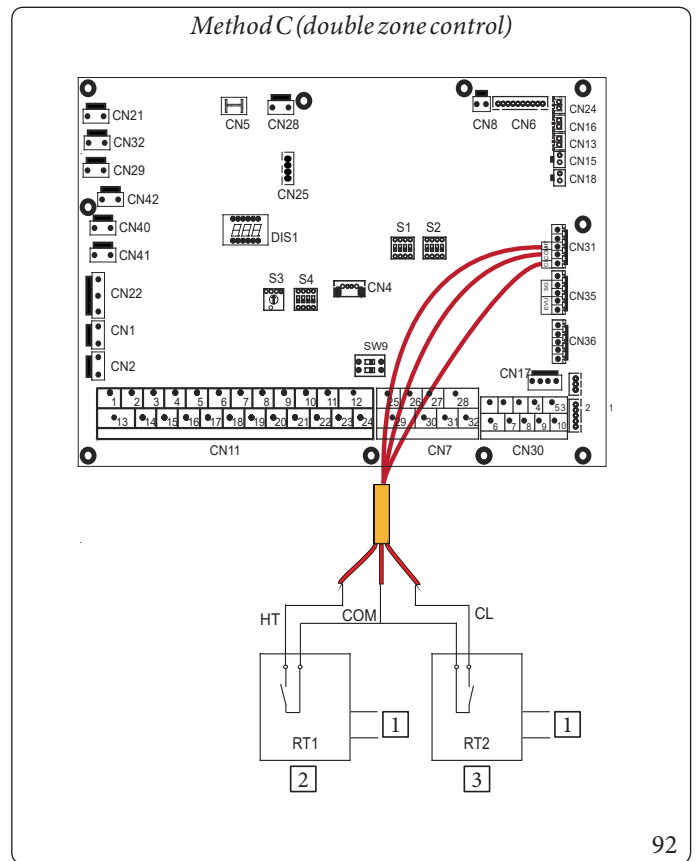
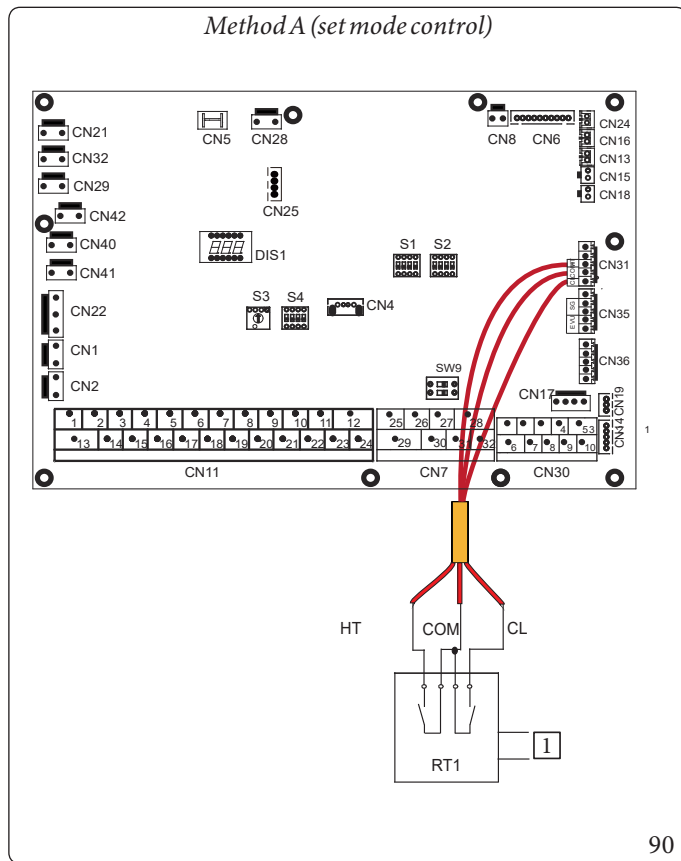

Legenda (Fig. 90 - 91 - 92):

- 1 - Power supply input
- 2 - Zone 1
- 3 - Zone 2



There are three methods to connect the thermostat cable (as described in the previous images) and it depends on the application.

- **METHOD A (Set mode control).**

RT can control heating and cooling individually, like the control panel for 4-pipe FCU.

When the hydraulic module is connected with the external temperature controller, on the control panel, in the "FOR SERVICEMAN" menu, set "6.1 ROOM THERMOSTAT" at "MODE SET":

- A.1 When the unit detects a 12VDC voltage between CL and COM, the unit runs in cooling mode.
- A.2 When the unit detects a 12VDC voltage between HT and COM, the unit runs in heating mode.
- A.3 When the unit detects a 0VDC voltage for both sides (CL-COM, HT-COM), the unit stops operating for floor heating or cooling.
- A.4 When the unit detects a 12VDC voltage for both sides (CL-COM, HT-COM), the unit runs in cooling mode.

- **METHOD B (One zone control).**

RT supplies the switching signal to the unit. In the control panel, in the "FOR SERVICEMAN" menu set "6.1 ROOM THERMOSTAT" at "ONE ZONE":

- B.1 When the unit detects a 12VDC voltage between HT and COM, the unit switches on.
- B.2 When the unit detects a 0VDC voltage between HT and COM, the unit switches off.

- **METHOD C (Double zone control).**

The hydraulic module is connected with two room thermostats, on the control panel, in the "FOR SERVICEMAN" menu, set "6.1 ROOM THERMOSTAT" at "DOUBLE ZONE":

- C.1 When the unit detects a 12VDC voltage between HT and COM, zone 1 switches on. When the unit detects a 0VDC voltage between H and COM, zone 1 switches off.
- C.2 When the unit detects a 12VDC voltage between CL and COM, zone 2 switches on depending on the weather temperature curve. When the unit detects a 0VDC voltage between CL and COM, zone 2 switches off.
- C.3 When HT-COM and CL-COM are detected as 0VDC, the unit switches off.
- C.4 When HT-COM and CL-COM are detected as 12VDC, both zone 1 and zone 2 switch on.



- The wiring of the thermostat matches the settings on the control panel Chap. 10.5 "Room Thermostat".
  - The power supply of the machine and of the room thermostat must be connected to the same Neutral Line.
  - When the "6.1 ROOM THERMOSTAT" is not set at NO, the indoor temperature sensor Ta cannot be set at a valid value.
  - Zone 2 can only operate in heating mode, when cooling mode is set on the control panel and Zone 1 is OFF, "CL" in Zone 2 closes, the system still remains "OFF". The wires of the thermostats for Zone 1 and Zone 2 must be installed correctly.
-

11. To activate the tank booster heater (TBH):

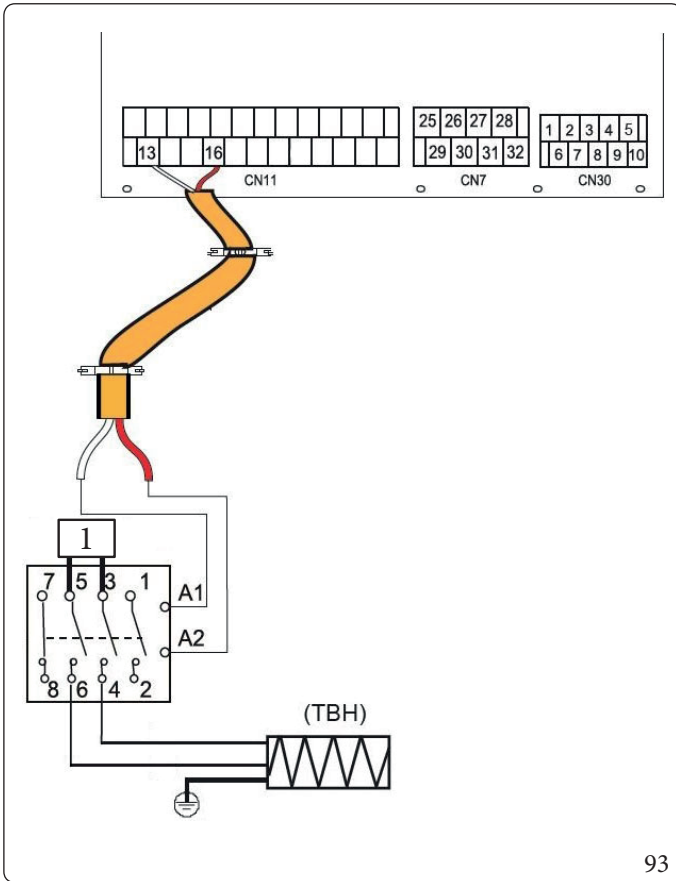

Key (Fig. 93):

1 - Power supply

Voltage	220-240VAC
Maximum operating current (A)	0,2
Minimum wiring size (mm <sup>2</sup> )	0,75
Type of signal of control port	Type 2



The unit only sends the ON/OFF signal to the heater.

12. For remote switch off:

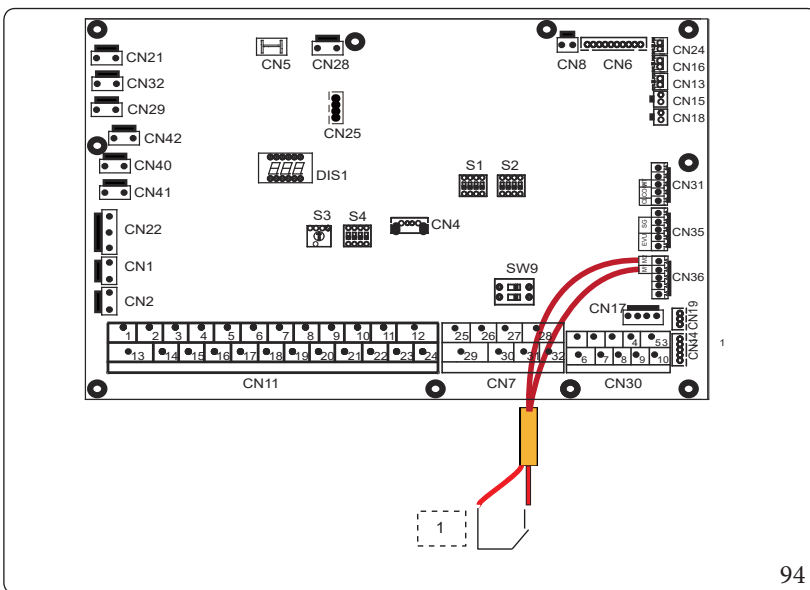

Legenda (Fig. 94):

1 - Close: Switch-off

13. For the alarm signal output:

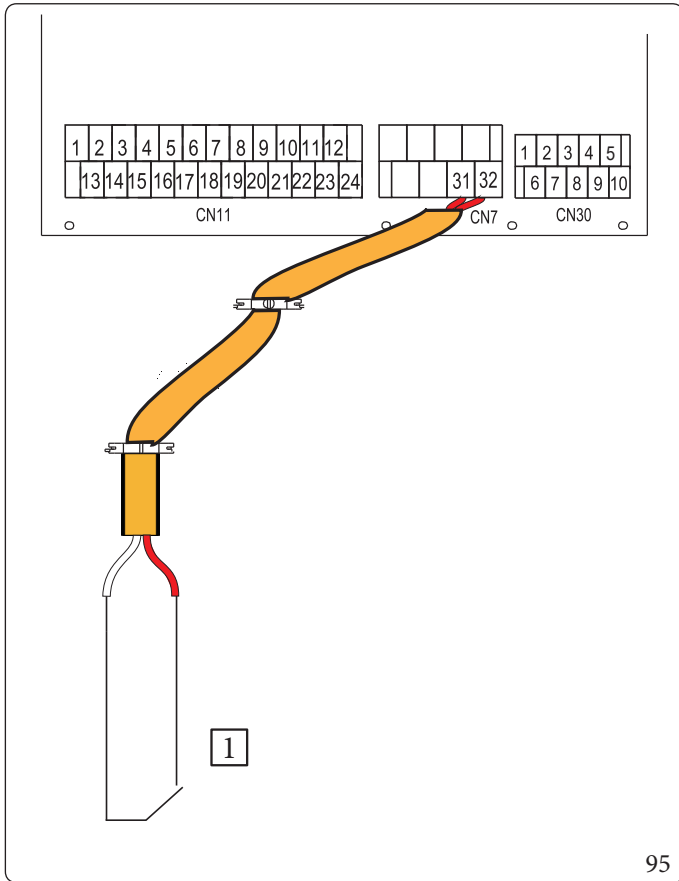

Legenda (Fig. 95):

1 - Alarm signal

Voltage	220-240VAC
Maximum operating current (A)	0,2
Minimum wiring size (mm <sup>2</sup> )	0,75
Type of signal of control port	Type 1

#### 14. For SMART GRID:

The unit has the smart grid function, there are two ports on the PCB to connect the SG signal and the EVU signal as follows:

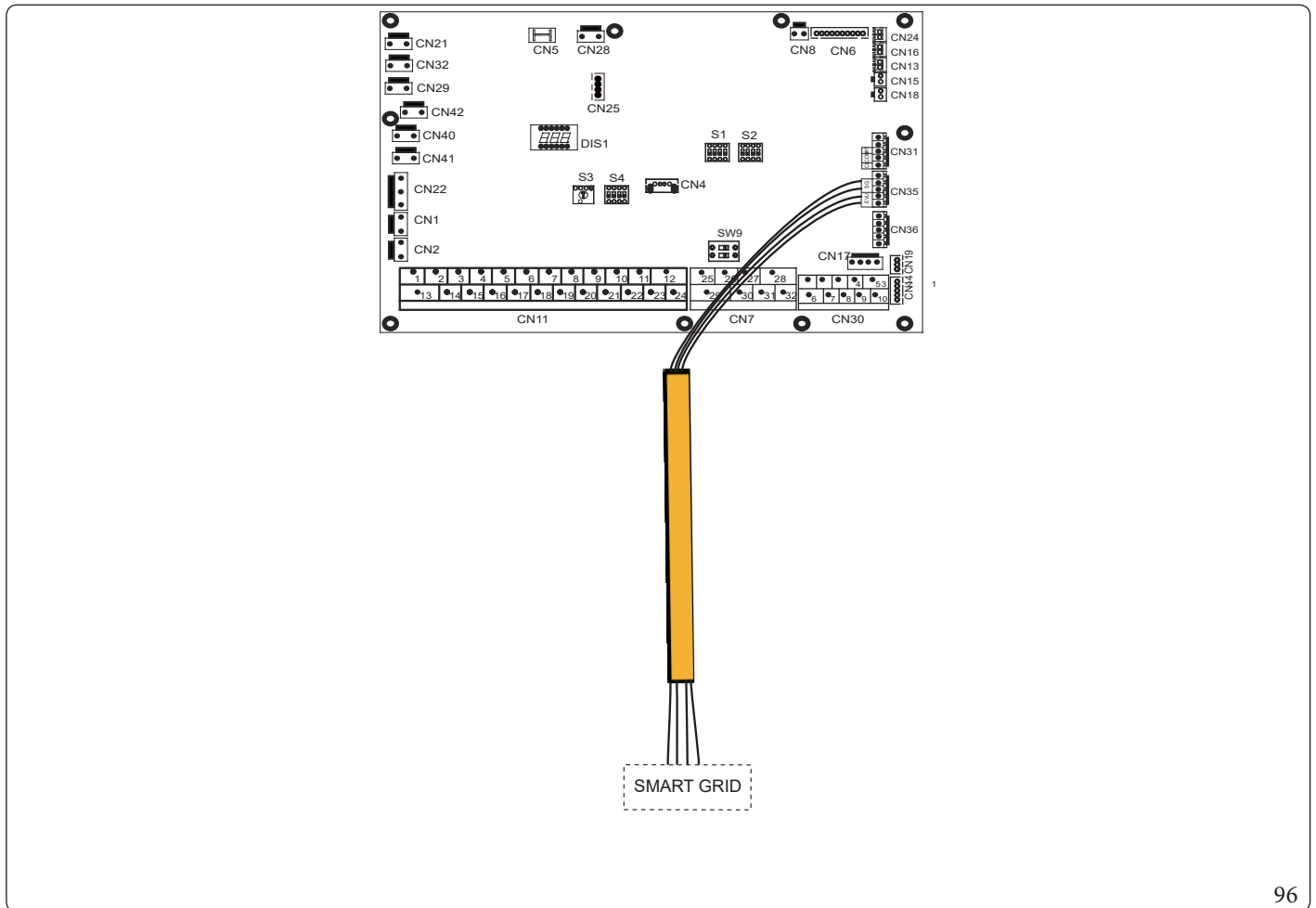

- 1) When the EVU contact is closed and the SG contact is closed, as long as DHW is enabled, the heat pump gives DHW mode priority and the temperature setpoint of the DHW mode switches to 70°C. If  $T5 < 69^\circ\text{C}$ , the TBH is active,  $T5 > 70^\circ\text{C}$ , the TBH is not active.
- 2) When the EVU contact is closed and the SG contact is open, as long as DHW mode is enabled and the mode is active, the heat pump gives DHW mode priority. If  $T5 < T5S - 2$ , the TBH is active, if  $T5 \geq T5S + 3$ , the TBH is not active.
- 3) When the EVU contact is open and the SG contact is closed, the unit runs normally.
- 4) When the EVU contact is open and the SG contact is open, the unit runs as follows: the unit will not work in DHW mode and the TBH will not be valid; the disinfect function will not be valid. The maximum operating time for cooling/heating is "SGRUNNINGTIME", then the unit will switch off.



As per standard, the SMART GRID function is deactivated. If you wish to activate the photovoltaic contact and use it the usual way, the installer needs to link the SG contact (jumper inside the accessory bag) and use as EVU photovoltaic contact.

# 10 STARTUP AND CONFIGURATION.

The unit must be configured by the installer to be adapted to the installation environment (outside weather, installed options, etc.) and to the competence of the user.



It is important that all of the information in this chapter be read in sequence by the installer and that the system be configured as applicable.

## 10.1 OVERVIEW OF DIP SWITCH SETTINGS.

### Setting of the function.

The DIP switches S1, S2 and S4 are located on the board of the main hydraulic control module (see Chap.9.3 "Main control panel of hydraulic module.").



**Switch off power before making any changes to the DIP switch settings.**

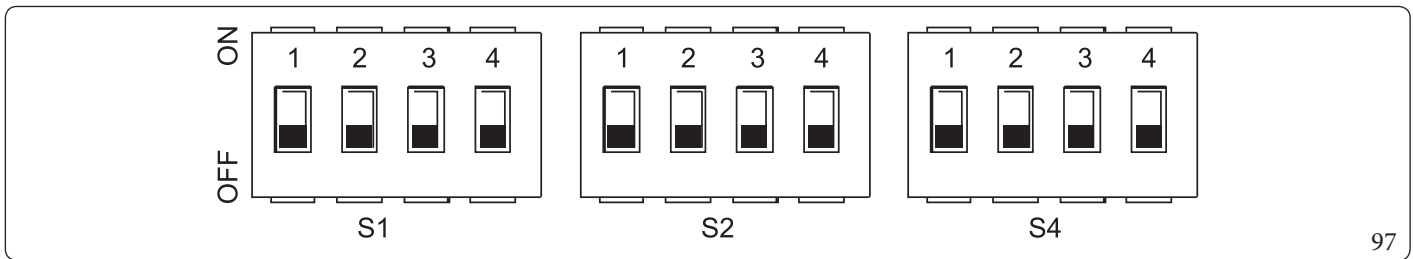

DIP Switch		ON=1	OFF=0	Default values
S1	1/2	0/0= IBH (One phase control) 0/1= IBH (Two phase control) 1/1= IBH (three phase control)		OFF/OFF (M4-6-8 EH3) ON/ON (M12-14-16 EH9)
	3/4	0/0= Without IBH 1/0= With IBH 0/1= Reserved 1/1= Reserved		ON / OFF

DIP Switch		ON=1	OFF=0	Default values
S2	1	Pump_O antiblock not active	Pump_O antiblock active every 24 hours	OFF
	2	without TBH	with TBH	OFF
	3/4	0/0= Reserved 0/1= Reserved 1/0= Reserved 1/1= pump for units 4-16 kW		ON / ON

DIP Switch		ON=1	OFF=0	Default values
S4	1	Master Unit: Resets the addresses of all the slave units Slave unit: Resets its own address	Maintains the current address	OFF
	2	IBH for DHW = active	IBH for DHW = not active	OFF
	3/4	Reserved		-

## 10.2 INITIAL START-UP AT LOW OUTDOOR TEMPERATURES.

During the initial start-up and when the water temperature is low, it is important to heat the water gradually. Otherwise the concrete floor could crack due to rapid temperature excursions. For further details, please contact the person in charge of making the concrete floor. To perform this operation, the minimum set flow temperature of the water can be reduced to a value between 25°C and 35°C by adjusting it on “FOR SERVICEMAN” (for the maintenance technician).  
Chap. 10.5 “Special Functions.”.

## 10.3 CHECKS PRIOR TO OPERATION.

Checks before the initial start-up.



### Switch of power before performing any connection.

After installing the unit, check the following before switching on the circuit breaker:

- **Wiring on field:** Make sure that the wiring on field between the local power supply panel and the unit and the valves (if applicable), the unit and the room thermostat (if applicable), the unit and the domestic hot water tank, has been connected according to the instructions given in Chap. 9.7 “Wiring on field.”, according to the wiring diagrams and local laws and regulations.
- **Fuses, circuit breakers or protective devices:** Check that the fuses or protective devices installed locally are the size and type specified in Chap. 14 “Technical specifications.”. Make sure that the fuses or protective devices have not been bypassed.
- **System indoor unit backup heater switch:** Do not forget to switch on the circuit breaker of the indoor unit backup heater in the control box. See the wiring diagram.
- **Heater of DHW storage tank switch:** Do not forget to switch on the circuit breaker of the booster heater (this only applies with the optional domestic hot water tank installed).
- **Earthing wiring:** Make sure that the earth wires are connected properly and that the earth terminals are tightened.
- **Internal wiring:** Visually check that there are no loose connections or damaged electric components.
- **Assembly:** Check that the unit is assembled correctly, to avoid anomalous noise and vibrations when starting the unit.
- **Damaged equipment:** Check that there are no damaged components or compressed pipes inside the appliance.
- **Refrigerant leak:** Check that there are no refrigerant leaks inside the unit. Contact your local dealer if there is a refrigerant leakage.
- **Power supply voltage:** Check the supply voltage on the local power supply panel. The voltage must match that indicated on the appliance’s rating plate.
- **Air purge valve:** Make sure that the air purge valve is open (at least 2 turns).
- **Shut-off valves:** Make sure that the shut-off valves are completely open.

## 10.4 THE CIRCULATION PUMP.

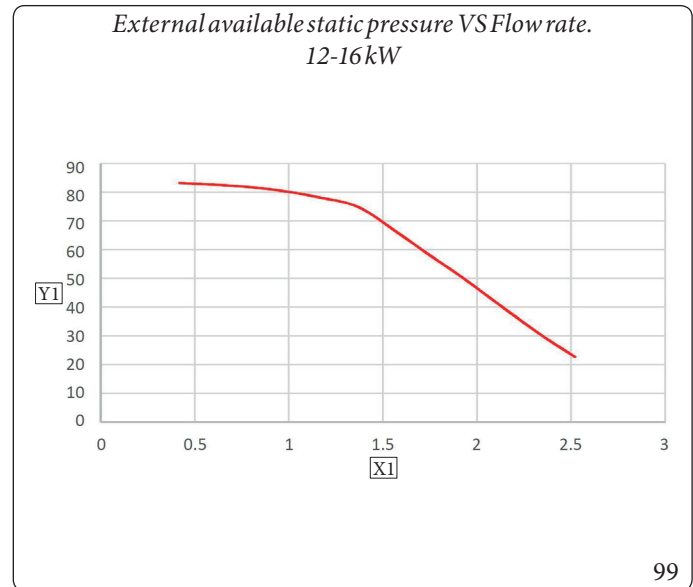
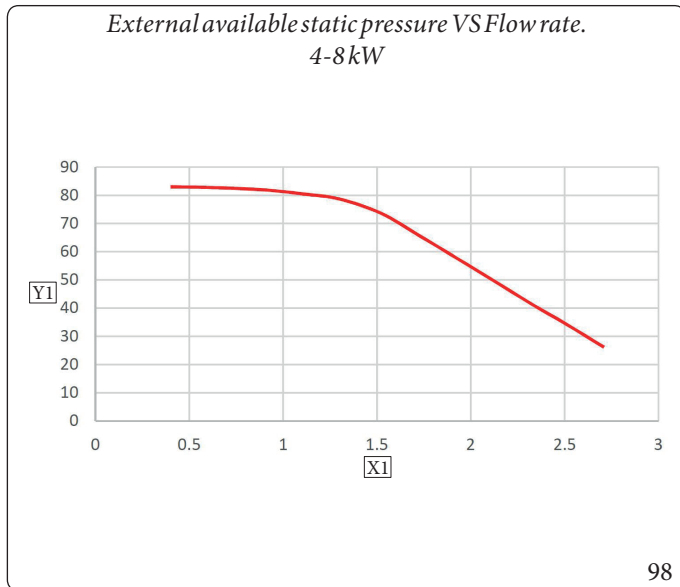

Key (Fig. 98 - 99):

- X1 - Flow rate (m³/h)
- Y1 - Available head (kPa)



If the valves are in the wrong position, the circulation pump is damaged.



**If the operation status of the pump needs to be checked when the unit switches on, please do not touch the internal components of the electric control box to avoid electric shocks.**

### • Troubleshooting at first installation.

- If nothing is displayed on the control panel, check for one of the following faults before diagnosing any error codes.
  - Disconnection or wiring error (between the power supply and the unit and between the unit and the control panel).
  - The fuse on the PCB could be blown.
- If the control panel displays “E8” or “E0” as error code, there could be air in the system, or the water level in the system might be lower than the minimum required.
- If the error code E2 is displayed on the control panel, check wiring between the control panel and the unit. Other error codes and causes of faults are found in section 13.4 “Error codes.”.

Have qualified personnel repair the faults.

## 10.5 ON-FIELD SETTINGS.

The unit must be configured based on the installation environment (outside weather, installed options, etc.) and on the request of the user. Several settings are available. These settings can be accessed and programmed from the section "FOR SERVICEMAN" on the control panel.

### Switching on the unit.

While the unit is switching on, "1%-99%" is displayed on the control panel during initialisation. The control panel cannot be used as long as this process is underway.

### Procedure.

To edit one or more settings, proceed as follows.



The temperature values used on the control panel are in °C.

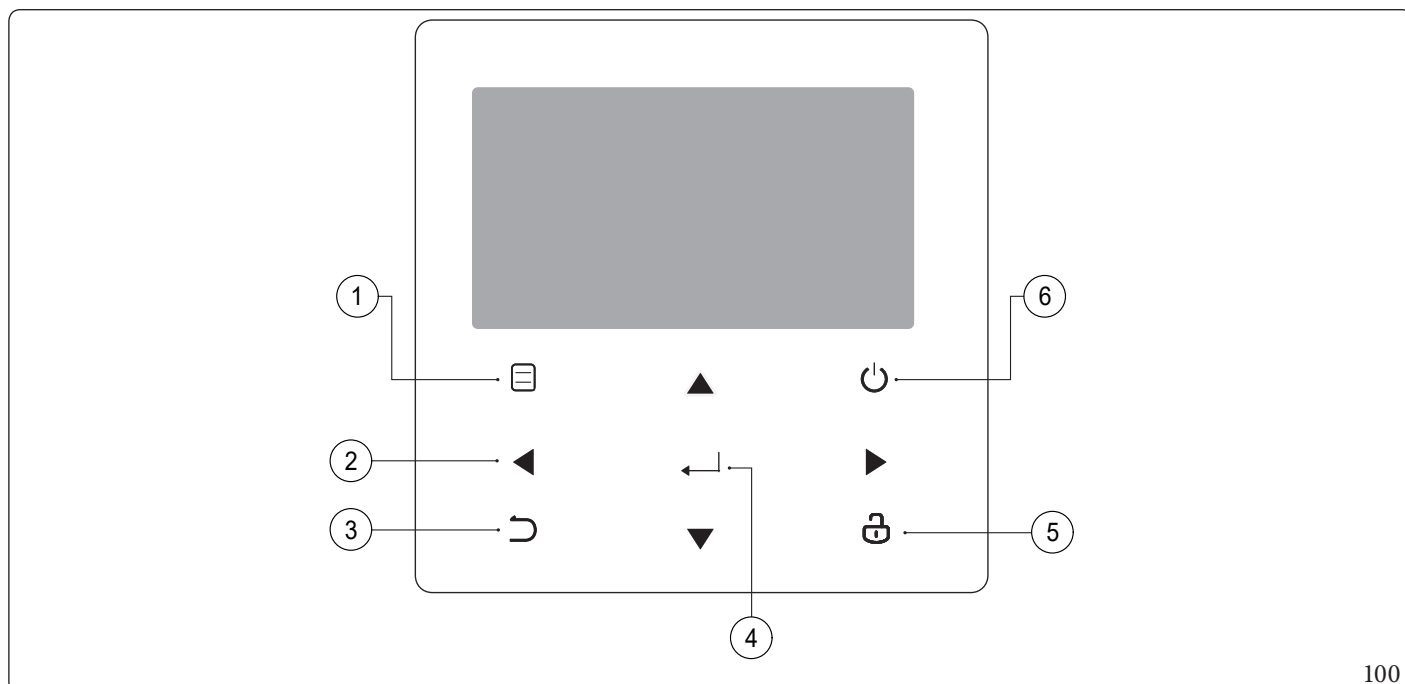

100

Reference	Icon	Function
1		Enter the menu structure from the home page.
2		Move the cursor on the display. Navigate in the menu structure. Adjust the settings.
3		Go back to higher level.
4		Go to the next step when programming a schedule in the menu structure. Confirm a selection. Enter a submenu in the menu structure.
5		Long press to unlock/lock the control panel. Release/block some functions like "DHW TEMP.ADJUST".
6		Activate or deactivate the room operation mode or "13.2 DHW MODE". Enable or disable the function in the menu structure.



### Information on “FOR SERVICEMAN”.





The “FOR SERVICEMAN” section is designed to allow the installer to set the parameters.

- Definition of the composition of the devices.
- Setting the parameters.

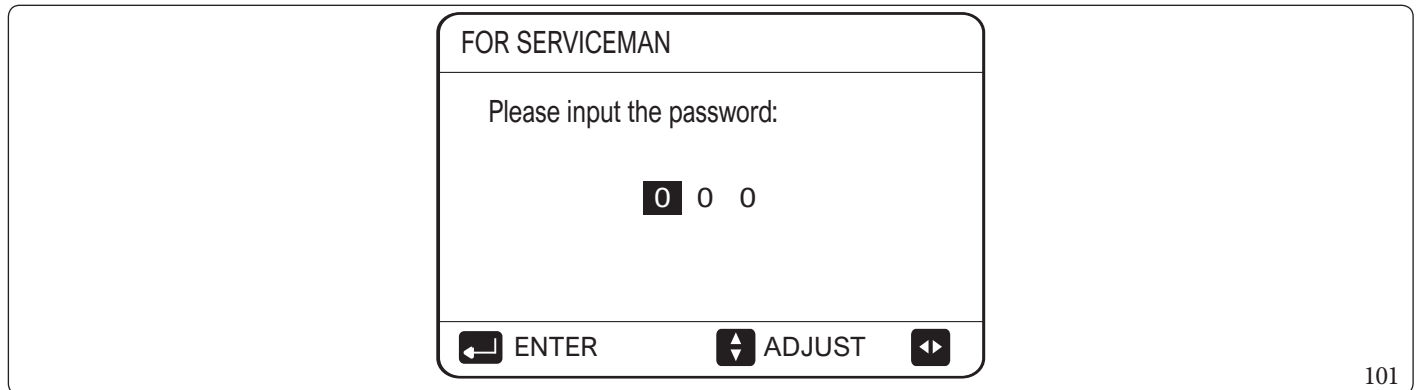
### How to access section “FOR SERVICEMAN”.

Goto  > FOR SERVICEMAN. Press  :



Press   to navigate and press   to adjust the numerical value. Press  . The password is 234, the following pages will be displayed after having entered the password:

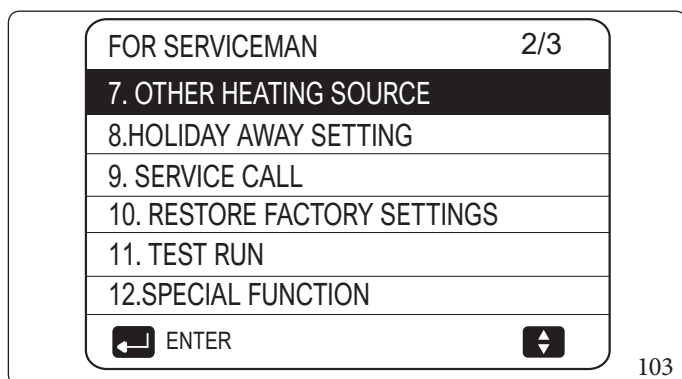
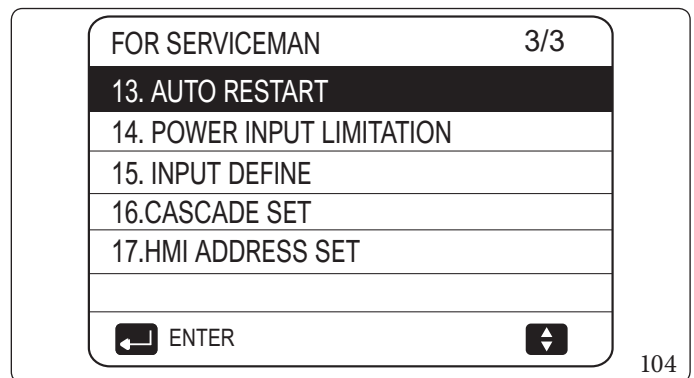
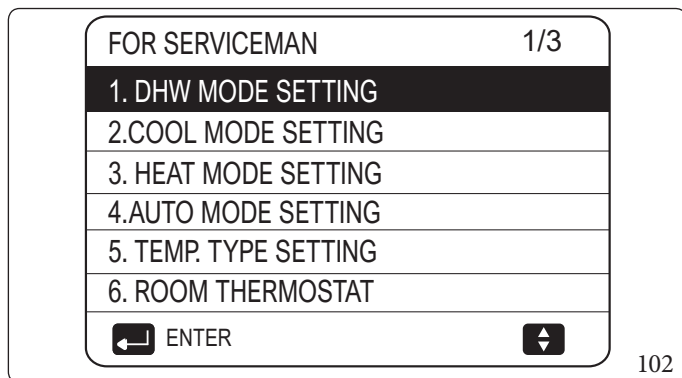



Press   to scroll and use  to access the submenu.

**Setting "13.2 DHW MODE".**



DHW = domestic hot water.

Go to  > FOR SERVICEMAN > 1. DHW MODE SETTING.



Press . The following pages will be displayed:

1. DHW MODE SETTING	1/5
1.1 DHW MODE	<b>YES</b>
1.2 DISINFECT	YES
1.3 DHW PRIORITY	YES
1.4 PUMP_D	YES
1.5 DHW PRIORITY TIME SET	NON
 ADJUST	



105

1. DHW MODE SETTING	4/5
1.16 t_DI_MAX	<b>210</b> MIN
1.17 t_DHWHP_RESTRICT	30 MIN
1.18 t_DHWHP_MAX	120 MIN
1.19 PUMP_D TIMER	YES
1.20 PUMP_D RUNNING TIME	5 MIN
 ADJUST	



108

1. DHW MODE SETTING	2/5
1.6 dT5_ON	<b>5</b> °C
1.7 dT1S5	10 °C
1.8 T4DHWMAX	43 °C
1.9 T4DHWMIN	-10 °C
1.10 t_INTERVAL_DHW	5 MIN
 ADJUST	

106



1. DHW MODE SETTING	5/5
1.21 PUMP_D DISINFECT RUN	<b>NON</b>
 ADJUST	



109

1. DHW MODE SETTING	3/5
1.11 dT5_TBH_OFF	<b>5</b> °C
1.12 T4_TBH_ON	5 °C
1.13 t_TBH_DELAY	30 MIN
1.14 T5S_DISINFECT	65 °C
1.15 t_DI_HIGHTEMP	15 MIN
 ADJUST	



107

**Setting "MODE COOLING".**



Goto  > FOR SERVICEMAN > 2. COOL MODE SETTING.  
Press . The following pages will be displayed:

2. COOL MODE SETTING	1/3
2.1 COOL MODE	<b>YES</b>
2.2 t_T4_FRESH_C	2.0 HOURS
2.3 T4CMAX	43°C
2.4 T4CMIN	20°C
2.5 dT1SC	5°C
 ADJUST	

110



2. COOL MODE SETTING	3/3
2.11 T4C2	<b>25°C</b>
2.12 ZONE1 C-EMISSION	FCU
2.13 ZONE2 C-EMISSION	FHL
 ADJUST	



112

2. COOL MODE SETTING	2/3
2.6 dTSC	<b>2°C</b>
2.7 t_INTERVAL_C	5 MIN
2.8 T1SetC1	10°C
2.9 T1SetC2	16°C
2.10 T4C1	35°C
 ADJUST	



111

**Setting "HEAT MODE".**



Goto  > FOR SERVICEMAN > 3. HEAT MODE SETTING.  
Press . The following pages will be displayed:

3. HEAT MODE SETTING	1/3
3.1 HEAT MODE	<b>YES</b>
3.2 t_T4_FRESH_H	2.0 HOURS
3.3 T4HMAX	16°C
3.4 T4HMIN	-15°C
3.5 dT1SH	5°C
 ADJUST	

113



3. HEAT MODE SETTING	3/3
3.11 T4H2	<b>7°C</b>
3.12 ZONE1 H-EMISSION	RAD.
3.13 ZONE2 H-EMISSION	FHL
3.14 t_DELAY_PUMP	2 MIN
 ADJUST	

115

3. HEAT MODE SETTING	2/3
3.6 dTSH	<b>2°C</b>
3.7 t_INTERVAL_H	5 MIN
3.8 T1SetH1	35°C
3.9 T1SetH2	28°C
3.10 T4H1	-5°C
 ADJUST	

114

**Auto Mode Setting.**

Go to  > FOR SERVICEMAN > 4. AUTO MODE SETTING.  
 Press . The following page will be displayed:

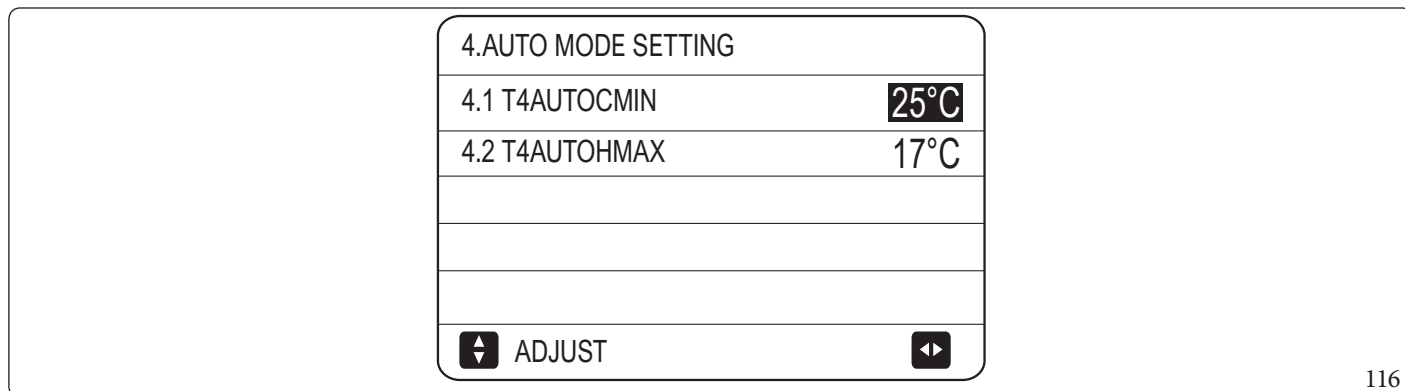

116



**Temp. Type Setting.**

• **Information on "5. TEMP. TYPE SETTING".**

The "5. TEMP. TYPE SETTING" menu is used to select whether the water flow temperature or the room temperature is used to control switching the heat pump on/off.

When the "5.2 ROOM TEMP." menu is enabled, the target water flow temperature will be calculated based on the climatic curves.

• **How to insert "5. TEMP. TYPE SETTING".**

Go to  > FOR SERVICEMAN > 5. TEMP. TYPE SETTING.  
 Press . The following page will be displayed:

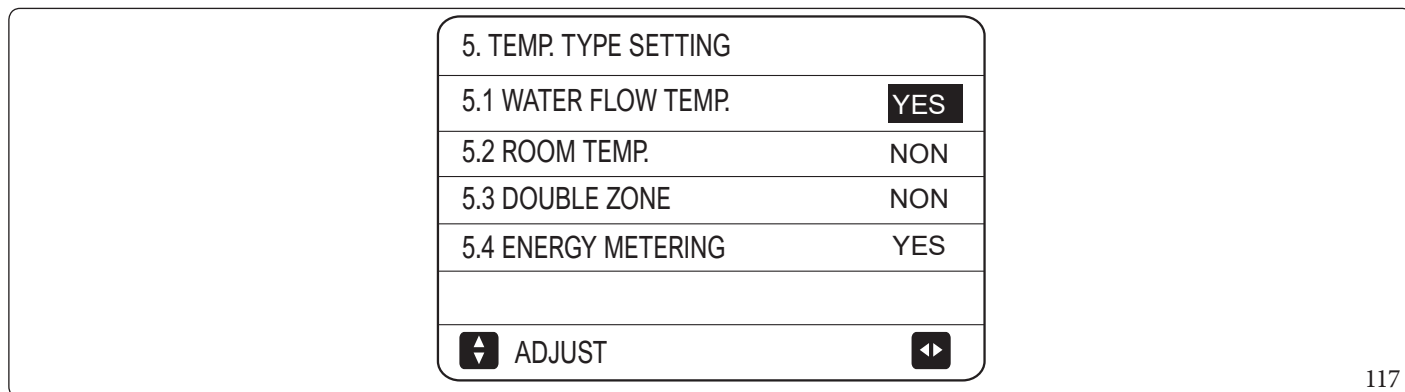

117

If only "5.1 WATER FLOW TEMP." is set at YES, or only the "5.2 ROOM TEMP." menu is set at YES, the following pages will be displayed:

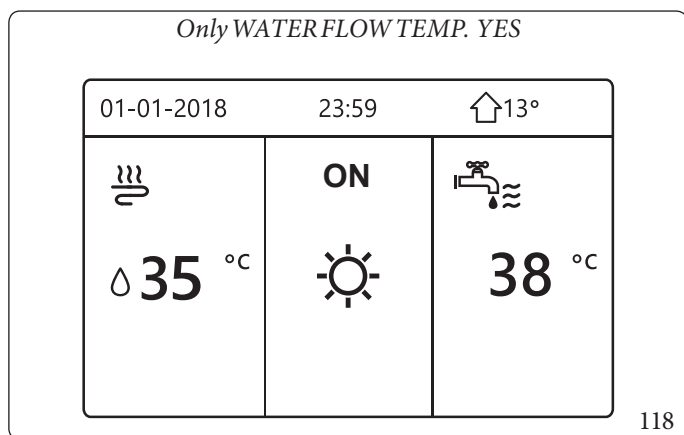

118

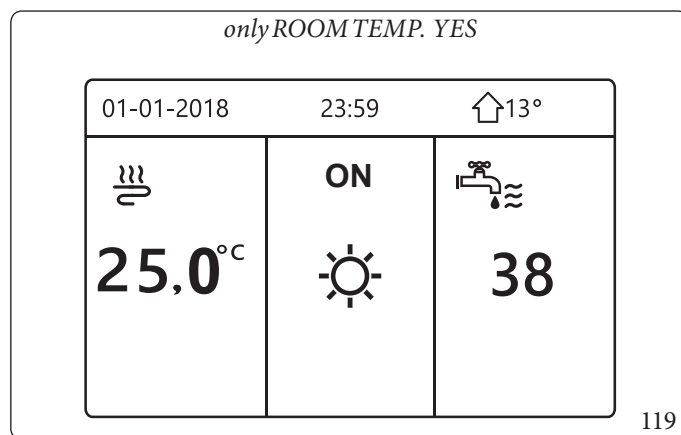

119

If "5.1 WATER FLOW TEMP." and "5.2 ROOM TEMP." menus are set at "YES", while "5.3 DOUBLE ZONE" is set at "NON" or "YES", the following pages will appear:

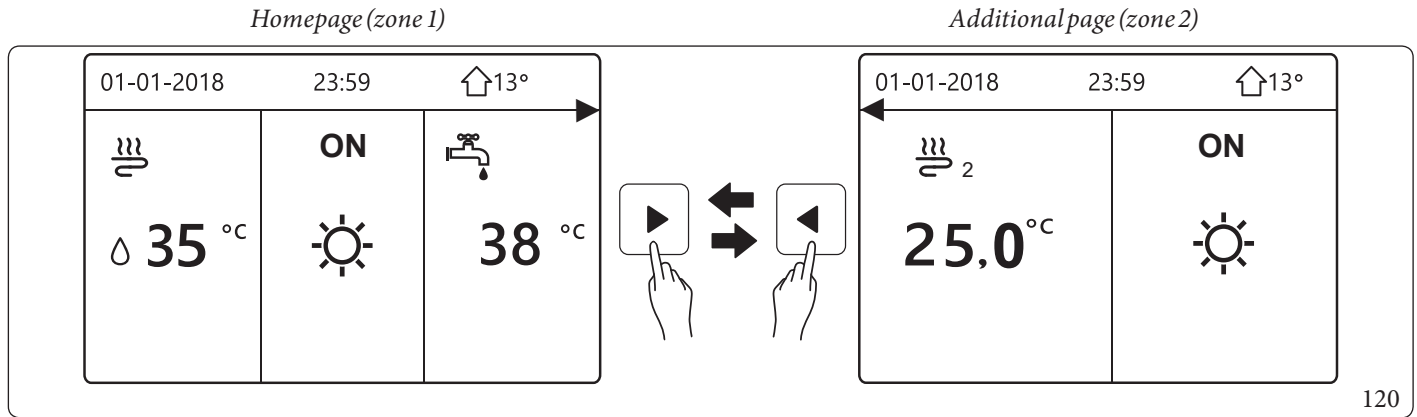

In this case, the setting value of zone 1 is T1S, the setting value of zone 2 is T1S2 (the corresponding T1S2 is calculated based on the climatic curves).

If "5.3 DOUBLE ZONE" is set at "YES" and "5.2 ROOM TEMP." is set at "NON", while "5.1 WATER FLOW TEMP." at "YES" or "NON", the following pages will be displayed:

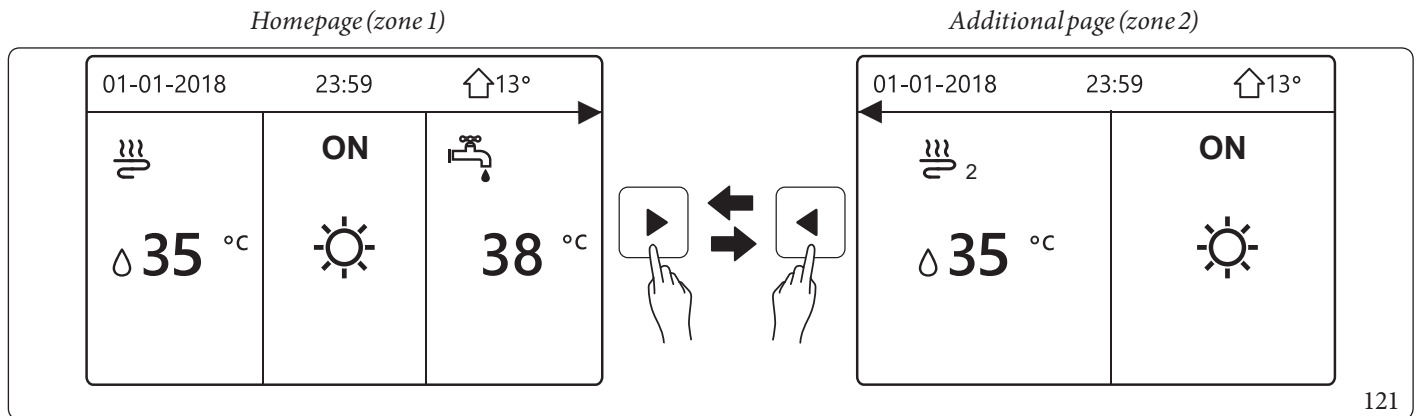

In this case, the setting value of zone 1 is T1S, the setting value of zone 2 is T1S2.

If "5.3 DOUBLE ZONE" and "5.2 ROOM TEMP." are set at "YES", while "5.1 WATER FLOW TEMP." at "YES" or "NON", the following pages will be displayed:

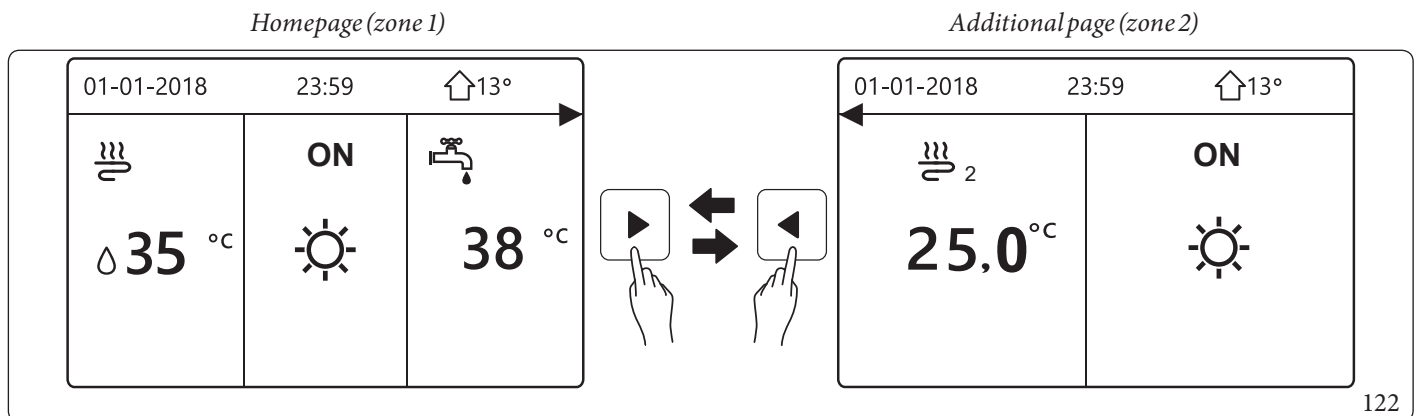

In this case, the setting value of zone 1 is T1S, the setting value of zone 2 is T1S2 (the corresponding T1S2 is calculated based on the climatic curves).

## Room Thermostat



- **"6. ROOM THERMOSTAT" menu information.**

The "6. ROOM THERMOSTAT" menu is used if the room thermostat is available.

- **How to set the "6. ROOM THERMOSTAT" menu.**

Go to  > FOR SERVICEMAN > 6. ROOM THERMOSTAT.

Press . The following page will be displayed:

6. ROOM THERMOSTAT	
6.1 ROOM THERMOSTAT	NON
 ADJUST	

123



6.1 ROOM THERMOSTAT = NON, no room thermostat.

6.1 ROOM THERMOSTAT = MODE SET, wiring of the room thermostat must follow method A.

6.1 ROOM THERMOSTAT = ONE ZONE, wiring of the room thermostat must follow method B.

6.1 ROOM THERMOSTAT = DOUBLE ZONE, wiring of the room thermostat must follow method C.



(see chapter 9.7 Par. "For room thermostat:").

## Other Heating Source.



"7. OTHER HEATING SOURCE" is used to set the parameters of the indoor unit backup heater (IBH).

Go to  > FOR SERVICEMAN > 7. OTHER HEATING SOURCE.

Press . The following pages will be displayed:

7. OTHER HEATING SOURCE	1/2
7.1 dT1_IBH_ON	5°C
7.2 t_IBH_DELAY	30 MIN
7.3 T4_IBH_ON	-5°C
7.4 dT1_AHS_ON	5°C
7.5 t_AHS_DELAY	30 MIN
 ADJUST	

124

7. OTHER HEATING SOURCE	2/2
7.6 T4_AHS_ON	5°C
7.7 IBH LOCATE	PIPE LOOP
7.8 P_IBH1	0,0kW
7.9 P_IBH2	0,0kW
7.10 P_TBH	2,0kW
 ADJUST	



125

### Setting Holiday Away.

"8.HOLIDAY AWAY SETTING" is used to set the outlet water temperature to prevent freezing during holidays.

Goto  > FOR SERVICEMAN > 8.HOLIDAY AWAY SETTING.

Press . The following page will be displayed:

8.HOLIDAY AWAY SETTING	
8.1 T1S_H.A_H	20°C
8.2 T5S_H.A._DHW	20°C
 ADJUST	



126

### Service Call.

The installers can set the phone number of the local dealer in "9. SERVICE CALL". If the unit does not work correctly, call this number to ask for help.



Goto  > FOR SERVICEMAN > 9. SERVICE CALL.

Press . The following page will be displayed:

9. SERVICE CALL	
PHONE NO.	0000000000000
MOBILE NO.	0000000000000
 ENTER	 ADJUST 

127

Press   to scroll and set the phone number. The maximum length of the phone number is 13 digits. If the phone number has less than 12 digits, enter  as shown below:

9. SERVICE CALL	
PHONE NO.	0000000000000
MOBILE NO.	0000000000000
 ENTER	 ADJUST 

128

The number displayed on the control panel is the phone number of your local dealer.

### Restore Factory Settings.

The factory setting "10. RESTORE FACTORY SETTINGS" is used to restore all the parameters set in the control panel to the factory setting.

Go to  > FOR SERVICEMAN > 10. RESTORE FACTORY SETTINGS.

Press . The following page will be displayed:

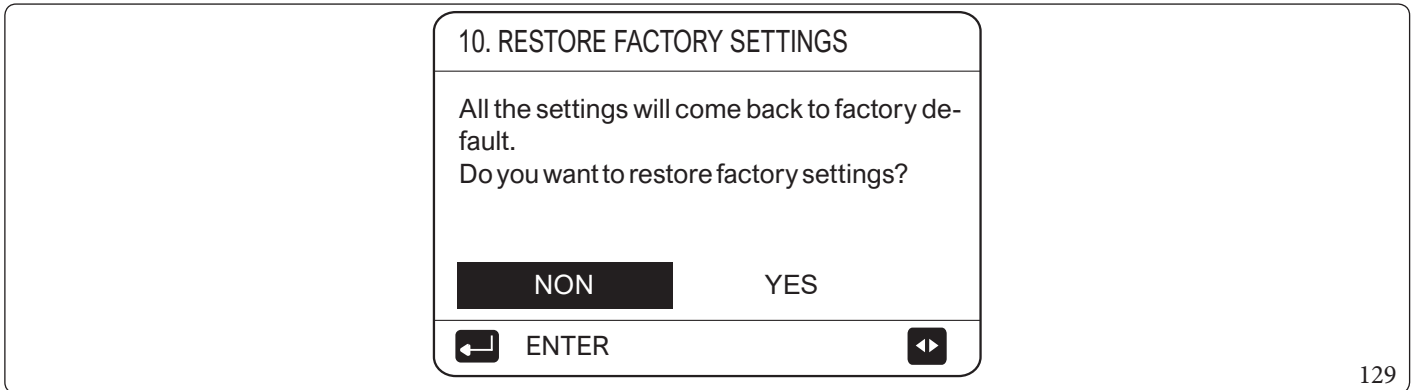

Press  to scroll the cursor to "YES" and press . The test operation switches off.

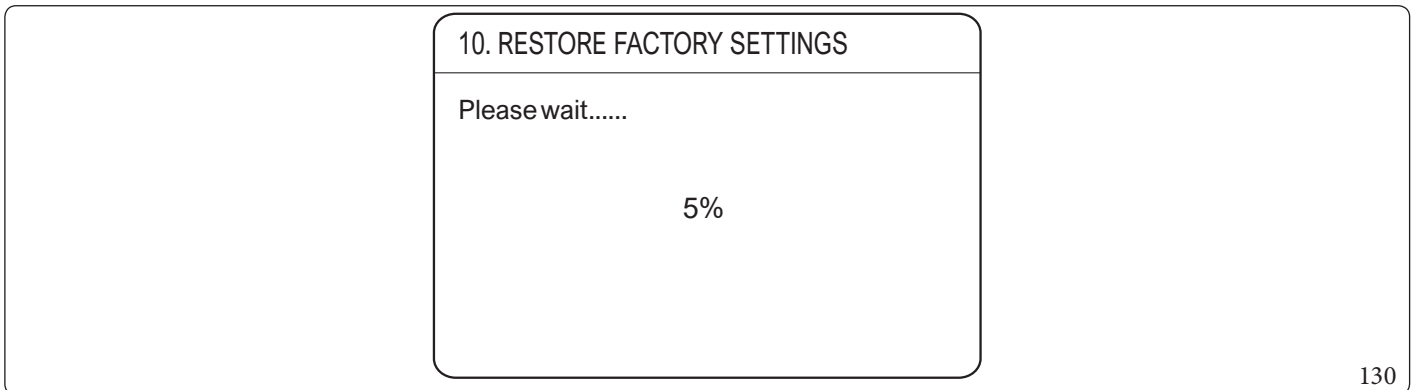

After a few seconds, all the parameters set in the control panel will be restored to the factory settings.



**Test Run.**

The "11. TEST RUN" menu is used to check correct operation of the valves, de-aeration, operation of the circulation pump, cooling, heating and domestic hot water heating.

Goto  > FOR SERVICEMAN > 11. TEST RUN.

Press . The following page will be displayed:

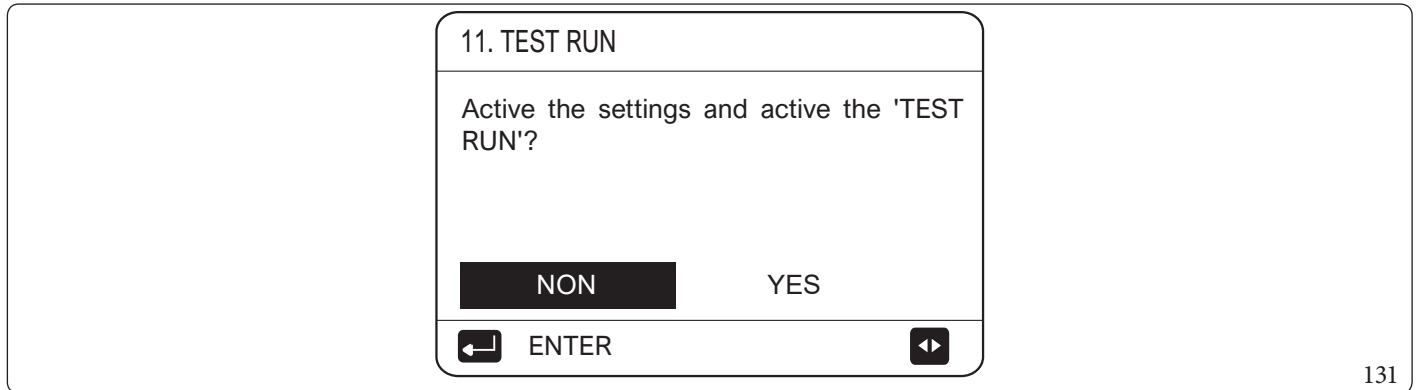

131

If "YES" is selected, the following pages will be displayed:

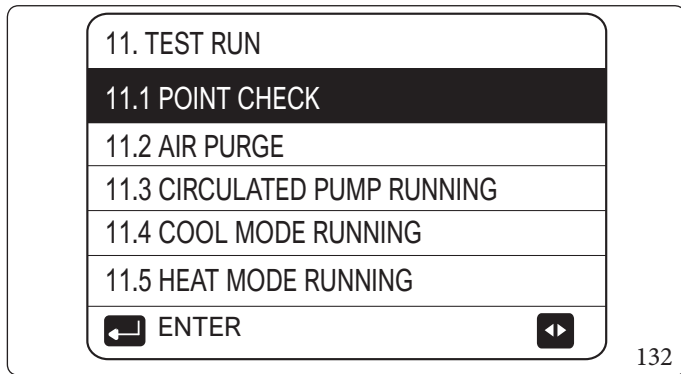

132

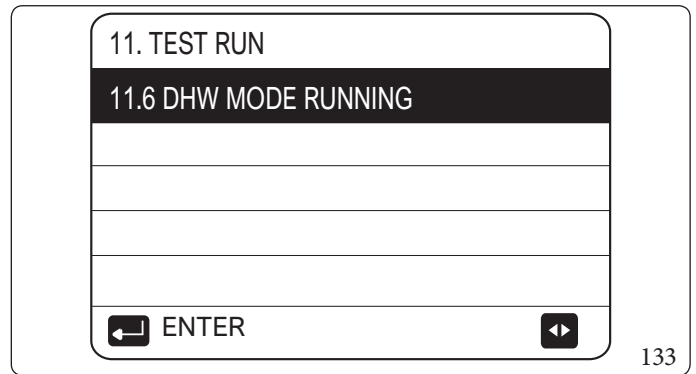

133

If "11.1 POINT CHECK" is selected, the following pages are displayed:

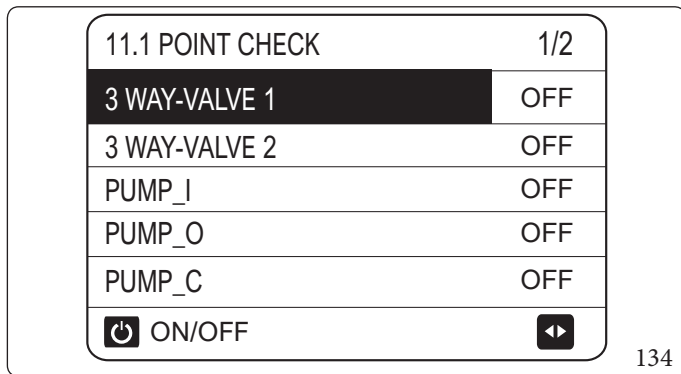

134

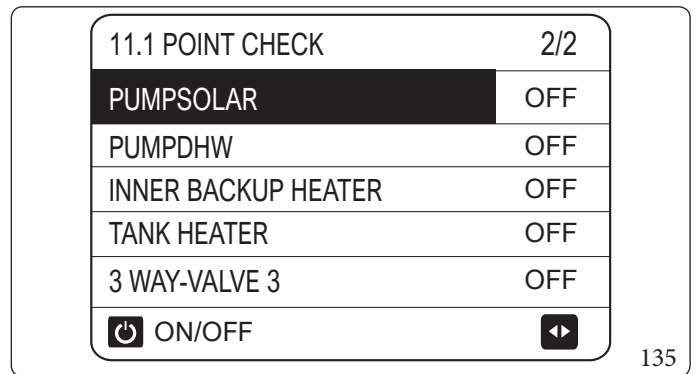

135

Press   to scroll to the components you want to check and press . For example, when the 3-way valve is selected and  is pressed, if the 3-way valve is open/closed, then operation of the 3-way valve is normal, as are the other components.

 Before the point check, make sure that the tank and water system are filled with water and air is ejected, otherwise the pump could be damaged.

If you select "11.2 AIR PURGE" and press , the following page is displayed:

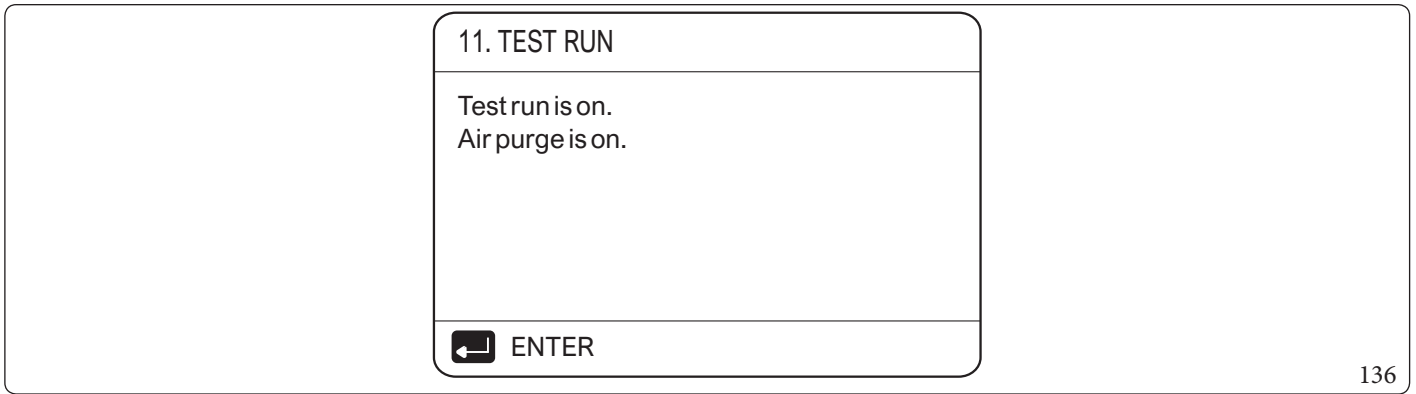

136

When in the air purge mode, SV1 opens, SV2 closes. 60 seconds later, the pump in the unit (PUMP\_I) will run for 10 minutes during which the flow switch will not work. After the pump stops, SV1 closes and SV2 opens. 60 seconds after both "PUMP\_I" and "PUMP\_O" will run until they receive the next command.

Selecting "11.3 CIRCULATED PUMP RUNNING" displays the following page:

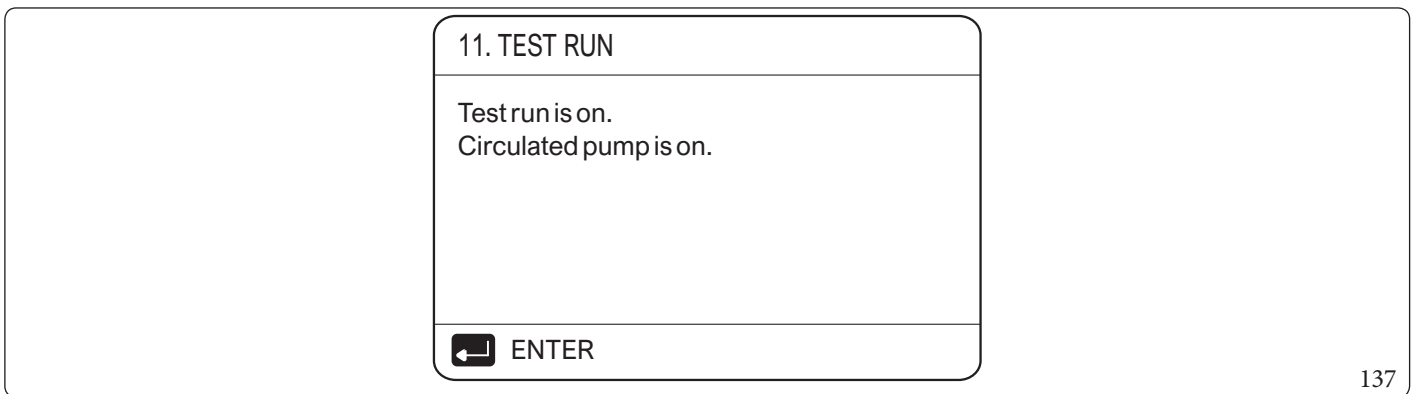

137

When the circulated pump test is running, all the components in operation will stop. 60 seconds after SV1 opens and SV2 closes. 60 seconds after "PUMP\_I" will run. 30 seconds after, if the flow switch verifies the presence of a normal flow rate, "PUMP\_I" will run for 3 minutes, then the pump stops for 60 seconds, SV1 closes and SV2 opens. 60 seconds after both "PUMP\_I" and "PUMP\_O" will start to run, 2 minutes later, the flow switch will check the water flow. If the flow switch closes for 15 seconds, "PUMP\_I" and "PUMP\_O" will run until they receive the next command.

Selecting "11.4 COOL MODE RUNNING" displays the following page:

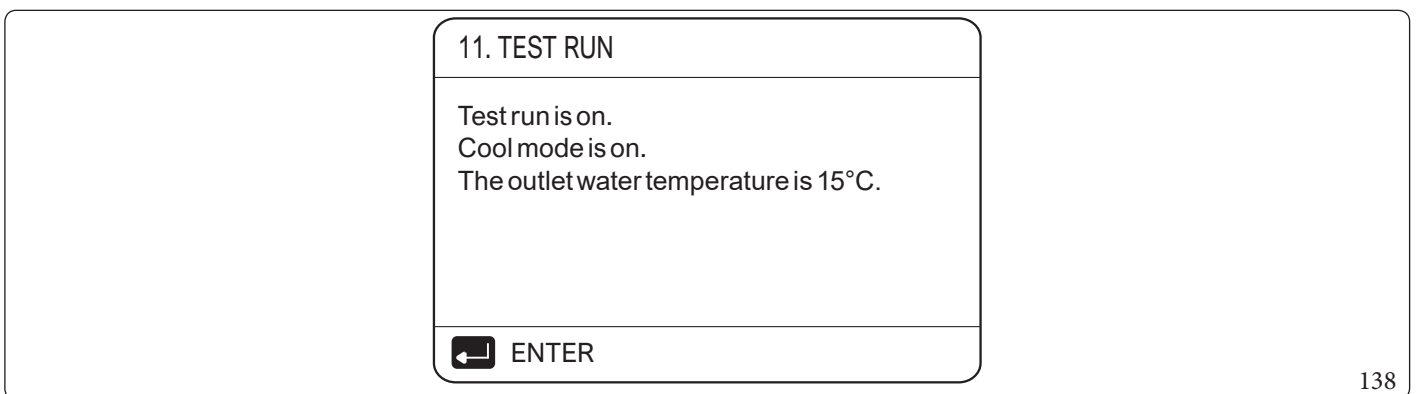

138

During operation of the "COOL MODE" test, the default temperature of the outlet water is 7°C. The unit will operate until the water temperature drops to a certain value or a subsequent command is received.

When the "11.5 HEAT MODE RUNNING" function is selected, the following page is displayed:

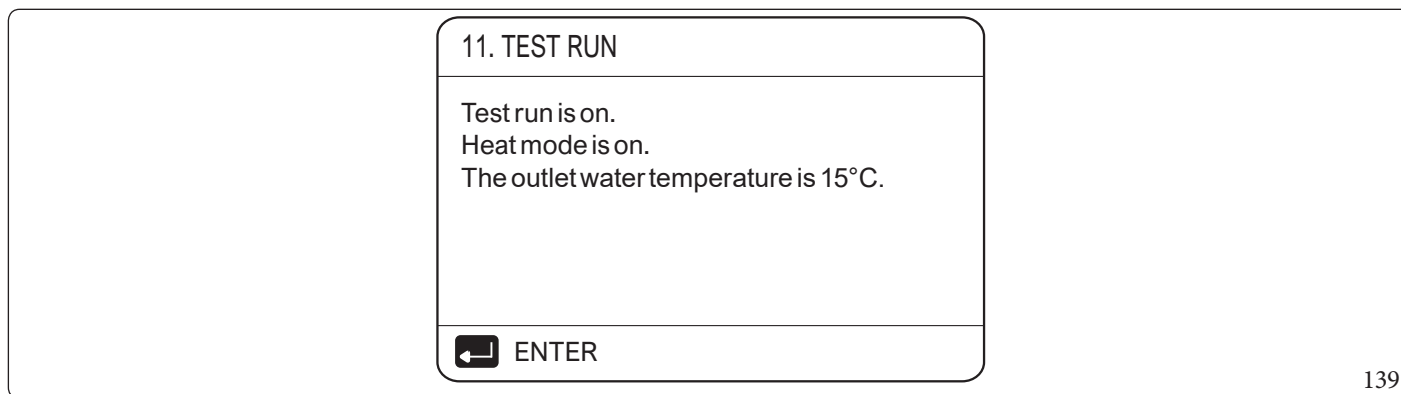

During execution of the "HEATING" test, the default temperature of the outlet water is 35°C. The IBH switches on after the compressor has been operating for 10 minutes. After 3 minutes of operation of the IBH, the IBH switches off, the heat pump runs until the water temperature increases to a certain value or another command is received.

Selecting "11.6 DHW MODE RUNNING" displays the following page:

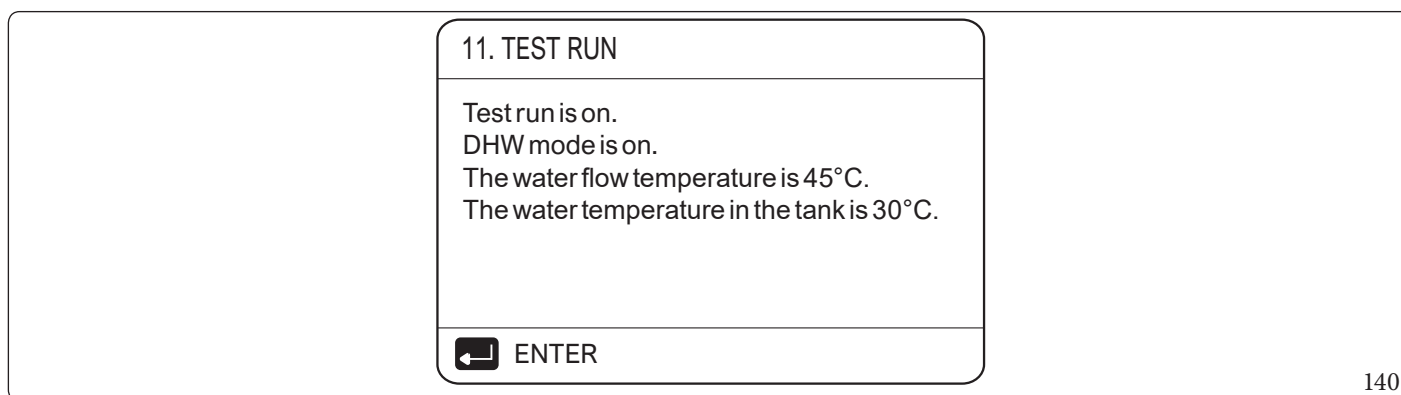

During execution of the DHW MODE test, the default temperature of the domestic hot water is 55°C. The TBH (DHW tank booster heater) switches on after the compressor has been operating for 10 minutes. The TBH will switch off 3 minutes later, the heat pump will run until the water temperature increases to a certain value or another command is received.

During execution of the test, only the button remains valid. If you want to interrupt the test, press . For example, when the unit is in air purge mode, after having pressed , the following page is displayed:

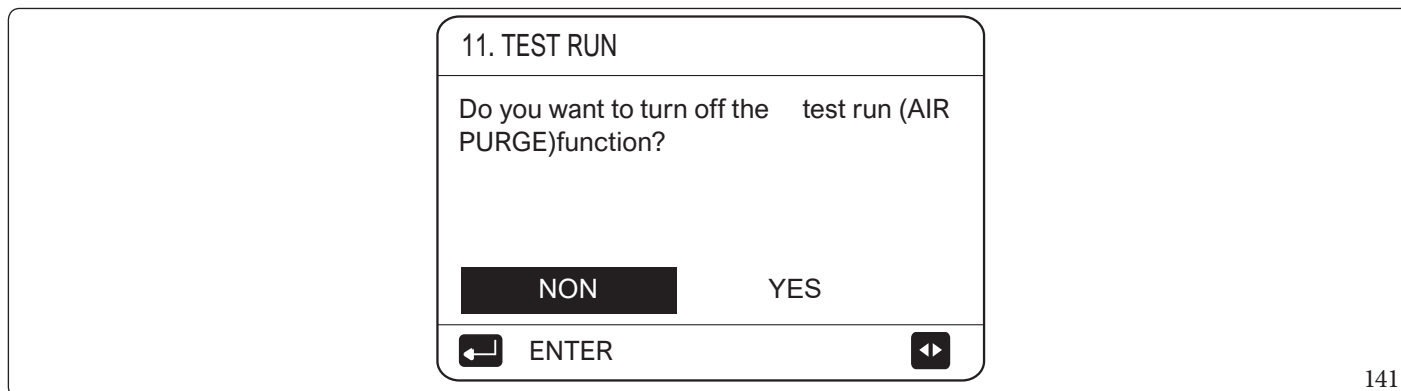

Press to scroll the cursor to "YES" and press . The test operation switches off.

## Special Functions.

When in special function mode, the control panel cannot work, it does not go back to the main screen and the screen shows the page that executes the special function, the control panel does not block.



During operation of special functions, other functions cannot be used (WEEKLY SCHEDULE/TIMER, HOLIDAY AWAY, HOLIDAY HOME).

Go to > FOR SERVICEMAN > 12.SPECIAL FUNCTION.

Before floor heating, if a large amount of water remains on the floor, the floor could deform or even break during the floor heating operation. In order to protect the floor, it must be dried and the floor temperature must steadily increase.

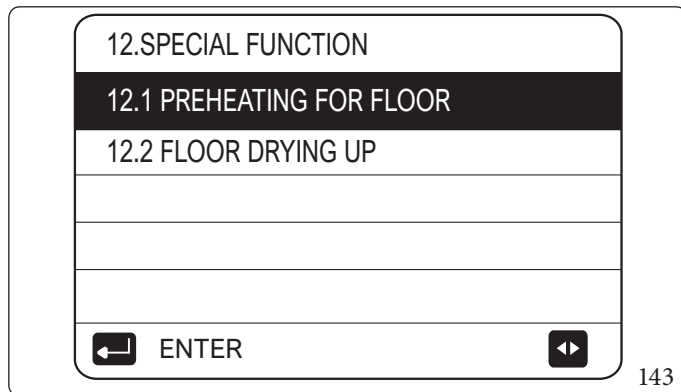
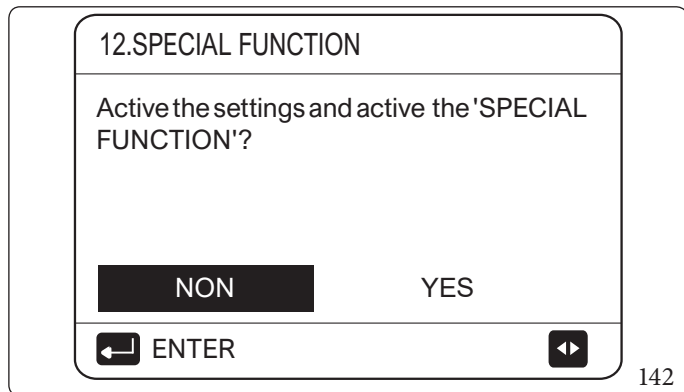

Press ▼▲ to scroll and press ↵ to enter.

During the initial operation of the unit, air could remain in the system and cause malfunctioning. It will be necessary to perform the air purge function (make sure that the air vent valve is open).

If "12.1 PREHEATING FOR FLOOR" is selected, the following pages are displayed:

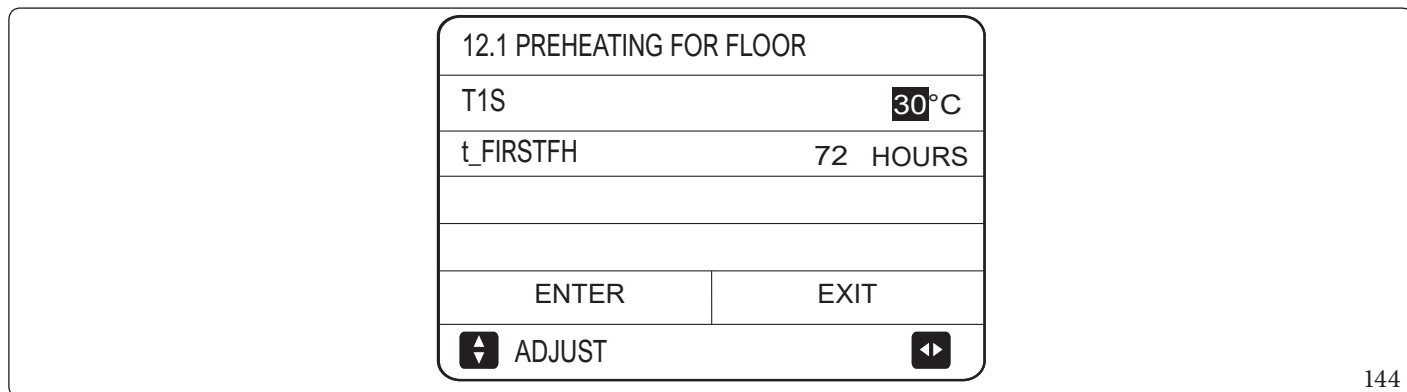

When the cursor is on "12.1 PREHEATING FOR FLOOR", use ▼▲ to scroll on "ENTER" and press ↵.

The following page will be displayed:

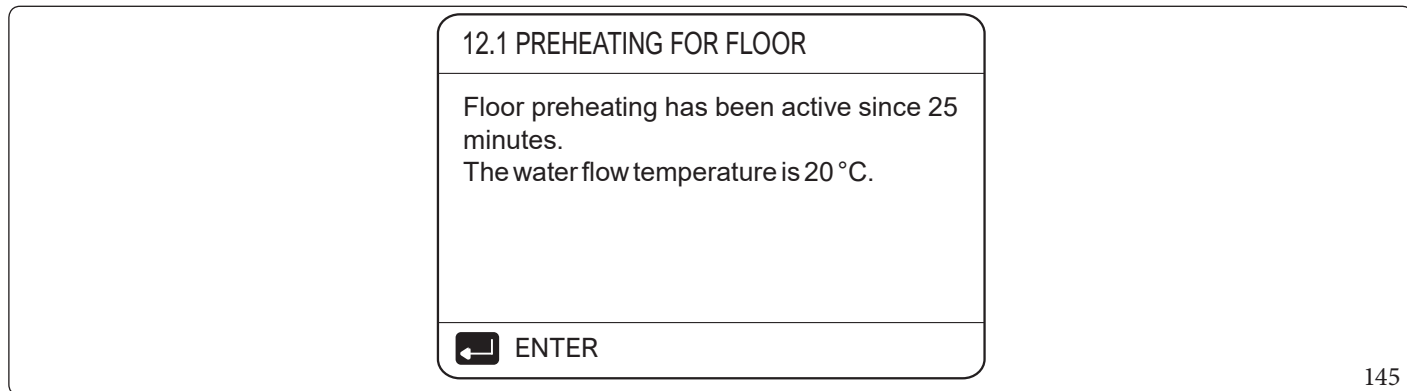

During preheating of the floor, only the ↵ button is valid. If you want to deactivate floor drying up, press ↵.

The following page will be displayed:

### 12.1 PREHEATING FOR FLOOR

Do you want to turn off the preheating for floor function?

NON
YES

← ENTER
▶

146

Use ◀▶ to scroll the cursor to "YES" and press ←, preheating for floor switches off.  
 Operation of the unit during preheating of the floor is described in the figure below:

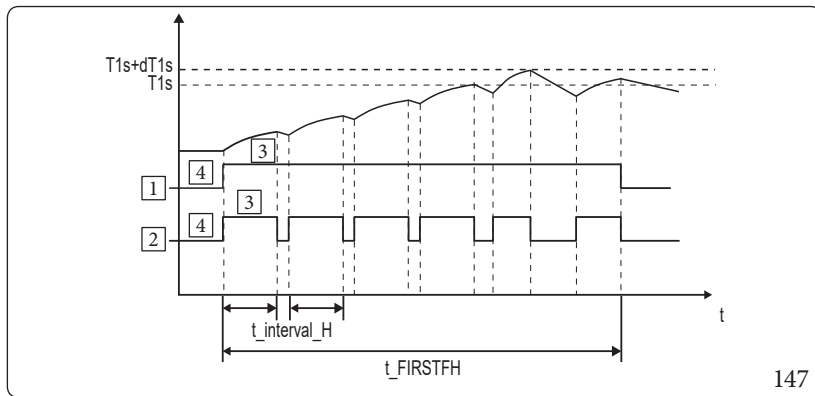

- Key (Fig. 147):
- 1 - Pump
  - 2 - Compressor
  - 3 - ON
  - 4 - OFF

If "12.2 FLOOR DRYING UP" item has been selected, after having pressed ←, the following pages will appear:

### 12.2 FLOOR DRYING UP

WARM UP TIME(t_DRYUP)	<b>8</b> DAYS
KEEP TIME(t_HIGHPEAK)	5 DAYS
TEMP.DOWN TIME(t_DRYD)	5 DAYS
PEAK TEMP.(t_DRYPEAK)	45°C
START TIME	15:00

◀ ADJUST
▶

148

### 12.2 FLOOR DRYING UP

START DATE	<b>01</b> -01-2019
ENTER	EXIT

◀ ADJUST
▶

149

Use ▼▲ to scroll to "ENTER" and press ←. The following page will be displayed:

### 12.2 FLOOR DRYING UP

The unit will operate floor drying up on  
09:00 01-08-2018.

← ENTER

150

During floor drying up, only the  button is valid. When the heat pump is not running, the floor drying up mode is deactivated when the backup heating source is not available. If you want to deactivate floor drying up, scroll the cursor on "YES" and press .

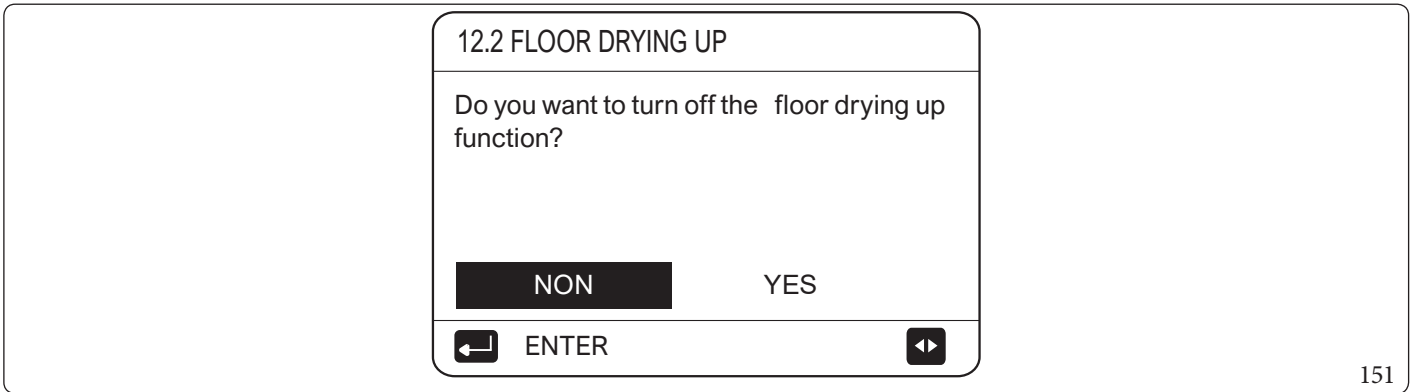

151

The target outlet water temperature during floor drying up is described in the image below:

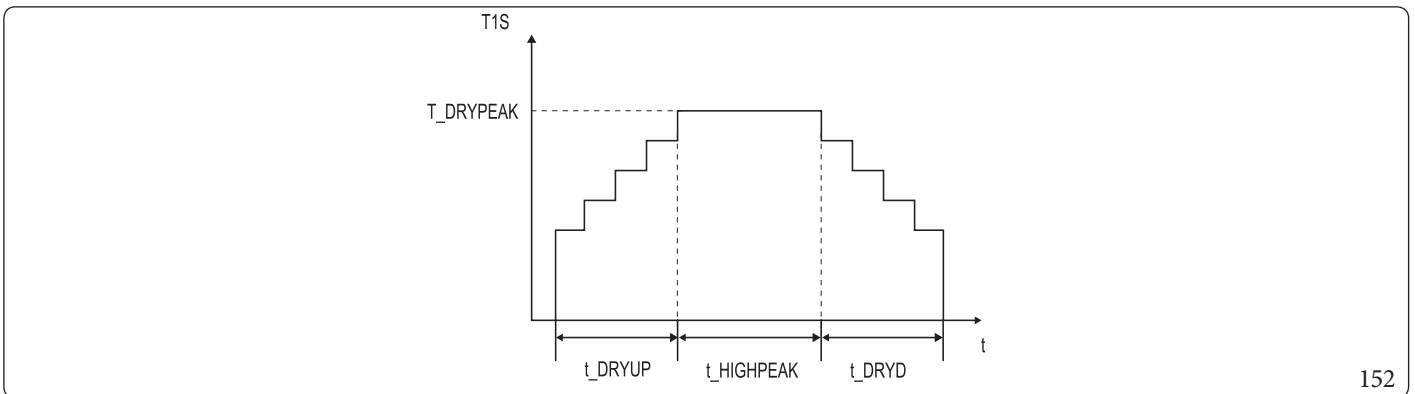

152

**Auto Restart.**

The "13. AUTO RESTART" function allows you to select whether the unit reapplies the settings of the control panel when the current returns after a power failure.

Go to  > FORSERVICEMAN > 13. AUTO RESTART.

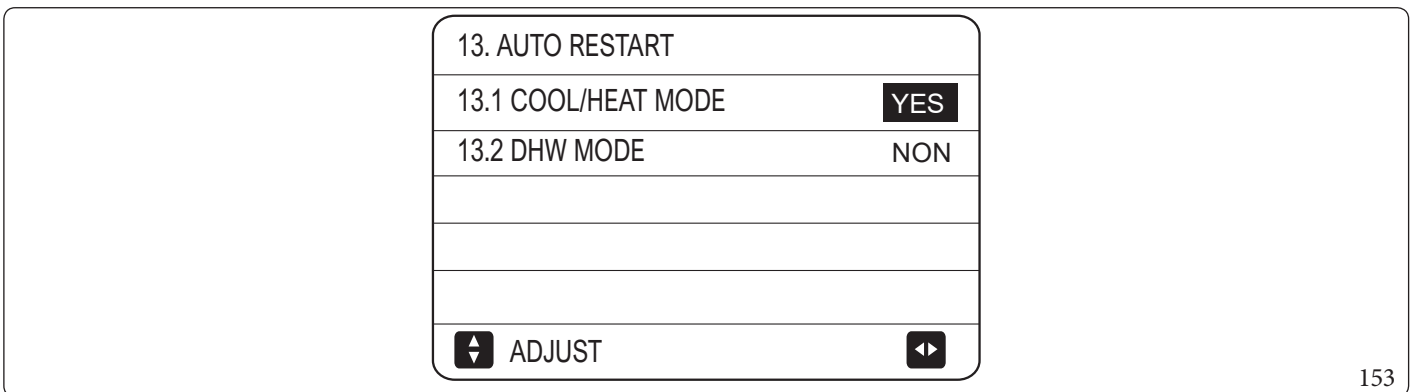

153

If this function is disabled, the unit will not restart automatically when current returns after a power failure.

## Limits Power Input

- **How to set in "14. POWER INPUT LIMITATION" menu.**

Goto  > FORSERVICEMAN > "14. POWER INPUT LIMITATION.

14. POWER INPUT LIMITATION

14.1 POWER INPUT LIMITATION 0

---



---





---



---



---

 ADJUST 

154

Limitation of input current, 0=NO, 1-8=TYPE 1-8 (the data are indicated in ampere) (A))

The following data are indicated in ampere) (A).

Model/Option	0	1	2	3	4	5	6	7	8
4-6kW	18	18	16	15	14	13	12	12	12
8kW	19	19	18	16	14	12	12	12	12
12-14-16kW	14	14	13	12	11	10	9	9	9

## Input Define.

- **How to set in "15. INPUT DEFINE" menu.**

Goto  > FORSERVICEMAN > 15.INPUT DEFINE.

15. INPUT DEFINE



15.1 M1/M2 0

15.2 SMART GRID NON

15.3 Tw2 NON

15.4 Tbt1 NON

15.5 Tbt2 NON

 ADJUST 

155

15. INPUT DEFINE

15.11 PUMP\_I SILENT MODE NON

15.12 DFT1/DFT2 ALARM



---



---



---

 ADJUST 

157

15. INPUT DEFINE



15.6 Ta HMI

15.7 Ta-adj. -2°C

15.8 SOLAR INPUT NON

15.9 F-PIPE LENGTH <10m

15.10 RT/Ta\_PCB NON

 ADJUST 

156





## Setting the parameters.

The parameters in this chapter are shown in the table below.

Order number - Code	Status	Default	Minimum	Maximum	Interval definition	Unit
1.1 DHW MODE	Enable or disable DHW mode: 0=NON, 1=YES	1	0	1	1	/
1.2 DISINFECT	Enable or disable disinfect mode: 0=NON, 1=YES	1	0	1	1	/
1.3 DHW PRIORITY	Enable or disable DHW priority mode: 0=NON, 1=YES	1	0	1	1	/
1.4 PUMP_D	Enable or disable the DHW pump: 0=NON, 1=YES	0	0	1	1	/
1.5 DHW PRIORITY TIME SET	Enable or disable the DHW priority time set: 0=NON, 1=YES	0	0	1	1	/
1.6 dT5_ON	The temperature difference to start the heat pump	10	1	30	1	°C
1.7 dT1S5	The difference value between Twout and T5 in DHW mode	10	5	40	1	°C
1.8 T4DHWMAX	The maximum outdoor temperature that the heat pump can manage for heating domestic hot water	43	35	43	1	°C
1.9 T4DHWMIN	The minimum outdoor temperature that the heat pump can manage for heating domestic hot water	-10	-25	30	1	°C
1.10 t_INTERVAL_DHW	The start time interval of the compressor in DHW mode	5	5	5	1	MIN.
1.11 dT5_TBH_OFF	The temperature difference between T5 and T5S that switches off the backup heater of the DHW storage tank	5	0	10	1	°C
1.12 T4_TBH_ON	The highest outdoor temperature with which the TBH can operate	5	-5	50	1	°C
1.13 t_TBH_DELAY	The operating time of the compressor before the DHW storage tank backup heater starts up	30	0	240	5	MIN.
1.14 T5S_DISINFECT	The water temperature in the domestic hot water tank in the "DISINFECT" function	65	60	70	1	°C
1.15 t_DI_HIGHTEMP	The holding time of the highest water temperature in the domestic hot water tank in the "DISINFECT" function	15	5	60	5	MIN.
1.16 t_DI_MAX	The maximum time duration of disinfect	210	90	300	5	MIN.
1.17 t_DHWHP_RESTRICT	Operation time for space heating/cooling	30	10	600	5	MIN.
1.18 t_DHWHP_MAX	The maximum continuous operation period of the heat pump in "1.3 DHW PRIORITY" mode	90	10	600	5	MIN.
1.19 PUMP_DTIMER	Enable or disable operation of the DHW pump as timed or continuous to operate for PUMP RUNNING TIME: 0=NON, 1=YES	1	0	1	1	/
1.20 PUMP_DRUNNING TIME	The certain time during which the DHW pump continues to run	5	5	120	1	MIN.
1.21 PUMP_DDISINFECT RUN	Enable or disable operation of the DHW pump when the unit is in disinfectant mode and T5≥T5S_DI-2: 0=NON, 1=YES	1	0	1	1	/

Ordernumber - Code	Status	Default	Minimum	Maximum	Interval definition	Unit
2.1 COOLMODE	Enable or disable cooling mode: 0=NON, 1=YES	1	0	1	1	/
2.2 t_T4_FRESH_C	The update time of the climatic curves for cooling mode	0,5	0,5	6	0,5	hours
2.3 T4CMAX	The highest outdoor temperature for cooling mode	52	35	52	1	°C
2.4 T4CMIN	The lowest outdoor operating temperature for cooling mode	10	-5	25	1	°C
2.5 dT1SC	The temperature difference to start the heat pump (T1)	5	2	10	1	°C
2.6 dTSC	The temperature difference to start the heat pump (Ta)	2	1	10	1	°C
2.7 t_INTERVAL_C	The start time interval of the compressor in COOL mode	5	5	5	1	MIN.
2.8 T1SetC1	The setting temperature 1 of the climatic curves for cooling mode	10	5	25	1	°C
2.9 T1SetC2	The setting temperature 2 of the climatic curves for cooling mode	16	5	25	1	°C
2.10 T4C1	The outdoor temperature 1 of the climatic curves for cooling mode	35	-5	46	1	°C
2.11 T4C2	The outdoor temperature 2 of the climatic curves for cooling mode	25	-5	46	1	°C
2.12 ZONE1 C-EMISSION	The type of zone1 terminal for cooling mode: CVC fan coil), RAD (do not use), CRP (floor radiant)	CVC	-	-	-	/
2.13 ZONE2 C-EMISSION	The type of zone2 terminal for cooling mode: CVC fan coil), RAD (do not use), CRP (floor radiant)	CVC	-	-	-	/
3.1 HEAT MODE	Activate or deactivate heating mode	1	0	1	1	/
3.2 t_T4_FRESH_H	The update time of the climatic curves for heating mode	0,5	0,5	6	0,5	hours
3.3 T4HMAX	The maximum outdoor operating temperature for heating mode	25	20	35	1	°C
3.4 T4HMIN	The minimum outdoor operating temperature for heating mode	-15	-25	30	1	°C
3.5 dT1SH	The temperature difference to start the unit (T1)	5	2	20	1	°C
3.6 dTSH	The temperature difference to start the unit (Ta)	2	1	10	1	°C
3.7 t_INTERVAL_H	The start time interval of the compressor in HEATING mode	5	5	5	1	MIN.
3.8 T1SetH1	The setting temperature 1 of the climatic curves for heating mode	35	25	65	1	°C
3.9 T1SetH2	The setting temperature 2 of the climatic curves for heating mode	28	25	65	1	°C
3.10 T4H1	The outdoor temperature 1 of the climatic curves for heating mode	-5	-25	35	1	°C
3.11 T4H2	The outdoor temperature 2 of the climatic curves for heating mode	7	-25	35	1	°C

Order number - Code	Status	Default	Minimum	Maximum	Interval definition	Unit
3.12 ZONE1 H-EMISSION	The type of zone1 terminal for heating mode: CVC fan coil), RAD (radiator), CRP (floor radiant)	RAD	-	-	-	/
3.13 ZONE2 H-EMISSION	The type of zone2 terminal for heating mode: CVC fan coil), RAD (radiator), CRP (floor radiant)	CRP	-	-	-	/
3.14 t_DELAY_PUMP	The delay time to stop the pump after the compressor stops	2	0,5	20	0,5	MIN.
4.1 T4AUTOCMIN	The minimum outdoor operating temperature for automatic cooling mode	25	20	29	1	°C
4.2 T4AUTOHMAX	The maximum outdoor operating temperature for automatic heating mode	17	10	17	1	°C
5.1 WATER FLOW TEMP.	Enable or disable "5.1 WATER FLOW TEMP.": 0=NON, 1=YES	1	0	1	1	/
5.2 ROOM TEMP.	Enable or disable "5.2 ROOM TEMP.": 0=NON, 1=YES	0	0	1	1	/
5.3 DOUBLE ZONE	Enable or disable "6. ROOM THERMOSTAT" "DOUBLE ZONE": 0=NON, 1=YES	0	0	1	1	/
5.4 ENERGY METERING	Energy measurement: 0=NON, 1=YES	1	0	1	1	/
6.1 ROOM THERMOSTAT	Room thermostat mode: 0=NON, 1=MODE SET, 2=ONE ZONE, 3=DOUBLE ZONE	0	0	3	1	/
7.1 dT1_IBH_ON	The temperature difference between T1S and T1 to start the backup heater.	5	2	10	1	°C
7.2 t_IBH_DELAY	The operating time of the compressor before the backup heater switches on. Includes the time interval between operation of the two backup heaters, if IBH is in two-phase control.	30	15	120	5	MIN.
7.3 T4_IBH_ON	The outdoor temperature for starting the backup heater	-5	-15	30	1	°C
7.4 dT1_AHS_ON	Not used	-	-	-	-	-
7.5 t_AHS_DELAY	Not used	-	-	-	-	-
7.6 T4_AHS_ON	Not used	-	-	-	-	-
7.7 IBH LOCATE	IBH installation position PIPE LOOP=0	0	0	0	0	/
7.8 P_IBH1	IBH1 power supply input	0	0	20	0,5	kW
7.9 P_IBH2	Not used	0	0	20	0,5	kW
7.10 P_TBH	TBH power supply input	2	0	20	0,5	kW
8.1 T1S_H.A_H	The target outlet water temperature for space heating in Holiday Away mode	25	20	25	1	°C
8.2 T5S_H.A._DHW	The target outlet water temperature for domestic hot water heating in Holiday Away mode	25	20	25	1	°C

Ordernumber - Code	Status	Default	Minimum	Maximum	Interval definition	Unit
12.1 PREHEATING FOR FLOOR - T1S	The outlet water temperature setting during initial preheating of the floor	25	25	35	1	°C
12.1 PREHEATING FOR FLOOR - t_FIRSTFH	Floor preheating duration	72	48	96	12	TIME
12.2 FLOOR DRYING UP - WARMUP TIME(t_DRYUP)	Heating days during floor drying up	8	4	15	1	DAY
12.2 FLOOR DRYING UP - KEEP TIME(t_HIGHPEAK)	High temperature holding days during floor drying up	5	3	7	1	DAY
12.2 FLOOR DRYING UP - WARMUP TIME(t_DRYUP)	Days of temperature drop during floor drying up	5	4	15	1	DAY
12.2 FLOOR DRYING UP - PEAK TEMP.(t_DRYPEAK)	Target peak temperature of the water flow during floor drying up	45	30	55	1	°C
12.2 FLOOR DRYING UP - START TIME	Floor drying up starting time	(*)	0:00	23:30	1/30	h/min
12.2 FLOOR DRYING UP - START DATE	Floor drying up starting date	The current date	1/1/2000	31/12/2099	01/01/2001	d/m/y
13.1 COOL/HEAT MODE	Enable or disable automatic cooling/heating restart mode: 0=NON, 1=YES	1	0	1	1	/
13.2 DHW MODE	Enable or disable automatic DHW restart mode: 0=NON, 1=YES	1	0	1	1	/
14.1 POWER INPUT LIMITATION	Limitation of input current, 0=NONN, 1-8=TYPE 1-8	0	0	8	1	/
15.1 M1/M2	Defines the function of the M1M2 switch: 0=heat pump remote ON/OFF, 1=TBH ON/OFF, 2= Not used	0	0	2	1	/
15.2 SMART GRID	Enable or disable the SMART GRID: 0=NON, 1=YES	0	0	1	1	/

(\*) Time: current hour (not in hour +1, in hour +2) - Minute: 00

Order number - Code	Status	Default	Minimum	Maximum	Interval definition	Unit
15.3 Tw2	Enable or disable T1b(Tw2): 0=NON, 1=YES	0	0	1	1	/
15.4 Tbt1	Enable or disable Tbt1: 0=NON, 1=YES	0	0	1	1	/
15.5 Tbt2	Not used	0	0	1	1	/
15.6 Ta	Enable or disable Ta: HMI=NON, IDU=YES	HMI	-	-	-	/
15.7 Ta-adj.	The correct Ta value on the control panel	-2	-10	10	1	°C
15.8 SOLARINPUT	Select SOLARINPUT: 0=NON, 1=Tsolar, 2=SL1SL2	0	0	2	1	/
15.9 F-PIPELENGTH	Not used	0	0	1	1	/
15.10 RT/Ta_PCB	Enable or disable RT/Ta_PCB: 0=NON, 1=YES	0	0	1	1	/
15.11 PUMP_I SILENT MODE	Activate or deactivate PUMPI SILENT MODE: 0=NON, 1=YES	0	0	1	1	/
15.12 DFT1/DFT2	DFT1/DFT2 door function: 0 = DEFROSTING 1 = ALARM	0	0	1	1	/
16.1 PER_START	Percentage for starting several units	10	10	100	10	%
16.2 TIME_ADJUST	Set the delay to add or subtract units	5	1	60	1	MIN.
16.3 ADDRESS RESET	Reset the address code of the unit. ("FF" is an invalid address code). After having set the address, press "  " to confirm.	FF	0	15	1	/
17.1 HMISET	Select the HMI: 0=MAIN, 1=SEC.	0	0	1	1	/
17.2 HMI ADDRESS FOR BMS	Set the HMI address code for BMS	1	1	255	1	/
17.3 STOP BIT	Set the stop bit value	1	1	2	1	/

# 11 TEST MODE AND FINAL CHECKS.

The installer must check that the unit works properly after installation.

## 11.1 FINAL CHECKS.

Before switching on the appliance, read the following recommendations:

- When installation is complete and all the necessary settings have been made, close all the front panels of the unit and put the unit cover back on.
- The service panel of the electric switchgear can only be opened by an authorised electrician for maintenance.



During the initial operation of the unit, the required power could be higher than that indicated on the unit's data nameplate. This is caused by the compressor which needs 50 hours of operation before reaching regular operation and stable energy consumption.

---

## 11.2 TEST OPERATION (MANUAL).

If necessary, the installer can perform a manual test operation at any time to check proper operation of the air purge, heating, cooling, domestic hot water heating, see Chap. 10.5 paragraph "Test Run."

# 12 MAINTENANCE AND SERVICE.

To guarantee ideal operation of the product, a series of checks and inspections on it and its wiring must be performed at regular intervals. Maintenance must be carried out by an authorised Immergas technician.



## ELECTRICAL SPARK

- **Before performing any maintenance or repairs, disconnect power to the electric control switchgear.**
- **Do not touch any live part for at least 10 minutes after disconnecting power.**
- **The compressor heater can even work in standby.**
- **It is prohibited to touch conductive parts.**
- **It is prohibited to wet the unit with water. This operation could trigger electrical discharges or fire.**
- **It is prohibited to leave the unit unattended if the protective casing has been removed.**

The following checks must be carried out **at least once a year** by qualified Immergas personnel.

- Water pressure.
  - Check the water pressure: if below 1 bar, restore it.
- Water filter.
  - Clean the water filter.
- Water safety valve.
  - Check that the safety valve works properly by turning the black knob on the valve anti-clockwise:
    - If no noise is heard, contact an authorised Immergas technician.
    - If water continues to leak from the unit, first close the water inlet and outlet shut-off valves and then contact an authorised Immergas technician.
- Flexible hose of the pressure relief valve.
  - Check that the flexible hose of the pressure relief valve is positioned appropriately to drain water.
- Electrical switchgear of the unit.
  - Perform a thorough visual inspection of the electrical switchgear, looking for evident defects such as loose connections or faulty wiring.
  - Check that the contactors work properly using a tester. All the contacts of these contactors must be in the open position.
- Use glycol (see paragraph “Anti-freeze protection of water circuit.” in chapter 9.4).
  - Record the concentration of glycol and the pH value in the water circuit at least once a year.
  - A pH value lower than 8.0 indicates that the inhibitor is running out and another inhibitor must be added.
  - When the pH value is lower than 7.0, it indicates glycol oxidation. The hydraulic circuit must be drained and rinsed thoroughly before causing serious damage.

Make sure that the glycol solution is disposed of in compliance with local standards and regulations.

# 13 TROUBLESHOOTING.

This section provides useful information for the diagnosis and correction of certain problems which can occur in the unit. Troubleshooting and the relative corrective actions can only be done by your local technician.

## 13.1 GENERAL GUIDELINES.

Before beginning troubleshooting, perform a thorough visual inspection of the unit, looking for evident defects such as loose connections or faulty wiring.



**When inspecting the main compartment of the unit, always make sure that the main switch of the unit is off.**

When a safety device has tripped, stop the unit and find out why the safety device tripped before resetting it. Under no such circumstances can the safety devices be linked or modified with a different device than that set in the factory. Call your local dealer if you cannot find the cause of the problem.

If the pressure relief valve does not work properly and needs to be replaced, always reconnect the flexible hose connected to the pressure relief valve to prevent water from dripping from the unit.

## 13.2 GENERAL SYMPTOMS.

Symptom 1: the unit is on but does not heat or cool as expected.

POSSIBLE CAUSES	CORRECTIVE ACTION
The temperature setting is not correct.	Check the parameters "3.3 T4HMAX", "3.4 T4HMIN" in heating mode. "3.3 T4HMAX", "3.4 T4HMIN" in cooling mode. T4DHWMAX, T4DHWMIN in "DHW" mode.
The water flow is too low.	Check that all the shut-off valves of the water circuit are in the right position. Check whether the water filter is clogged. Make sure there is no air in the water system. Check the water pressure: it should be >1 bar (with cold water). Make sure that the expansion vessel is not damaged. Check that the pressure drops of the hydraulic circuit are not too high for the pump.
The water volume in the system is too low.	Make sure that the water volume in the system is higher than the minimum required value (see paragraph "Water volume and dimensioning of the expansion vessels." chapter 9.4).

Symptom 2: the unit is on but the compressor does not start (space heating or domestic hot water heating).

POSSIBLE CAUSES	CORRECTIVE ACTION
The unit might be working outside of its operation range (the water temperature is too low).	In case of low water temperature, the system uses the backup heater to first reach the minimum water temperature (12°C). Check that the backup heater power supply is correct. Check that the backup heater thermal fuse is closed. Check that the backup heater thermal protection is not activated. Check that the backup heater contactors are not broken.



Symptom 3: the pump makes noise (cavitation).

POSSIBLE CAUSES	CORRECTIVE ACTION
There is air in the system.	Purge the air.
The pressure of the water entering the pump is too low.	Check the water pressure: it should be >1 bar (the water is cold). Check that the expansion vessel is not damaged. Check that the pre-pressure adjustment of the expansion vessel is correct (see paragraph "Water volume and dimensioning of the expansion vessels." in chapter 9.4).

Symptom 4: the water pressure safety valve opens.

POSSIBLE CAUSES	CORRECTIVE ACTION
The expansion vessel is damaged.	Replace the expansion vessel.
The filling water pressure of the system is higher than 0.3 MPa.	Make sure that the filling water pressure in the system is approximately 0.10-0.20 MPa (see paragraph "Water volume and dimensioning of the expansion vessels." chapter 9.4).

Symptom 5: lacking space heating capacity with low outdoor temperatures.

POSSIBLE CAUSES	CORRECTIVE ACTION
Backup heater operation is not enabled.	Check that "7. OTHER HEATING SOURCE" / Backup heater (IBH) is enabled, Chap. 10.3 "Checks prior to operation." Check whether the thermal protector of the backup heater has been activated or not. Check if the tank booster heater (TBH) is working, the backup heater (IBH) and the tank booster heater (TBH) cannot work at the same time.
An excessive capacity of the heat pump is used to heat the domestic hot water (this only applies for systems with domestic hot water storage tank).	Check that "1.18 t_DHWHP_MAX" and "1.17 t_DHWHP_RESTRICT" are configured appropriately. Make sure that "1.3 DHW PRIORITY" is disabled in the user interface. Activate the "1.12 T4_TBH_ON" in the user interface "FOR SERVICE MAN" to activate the DHW backup heater.

Symptom 6: heating mode cannot switch immediately to "DHW" mode.

POSSIBLE CAUSES	CORRECTIVE ACTION
The tank volume is too small and the position of the water temperature probe is not sufficiently high.	Set "1.7 dT1S5" at the maximum value and "1.17 t_DHWHP_RESTRICT" at the minimum value. Set "3.5 dT1SH" at 2°C Enable the TBH, and the TBH should be controlled by the unit.

Symptom 7: the "DHW" mode cannot switch immediately to heating mode.







POSSIBLE CAUSES	CORRECTIVE ACTION
Heat exchanger for space heating not large enough.	Set "1.18 t_DHWHP_MAX" at the minimum value, the recommended value is 60 min. If the circulation pump outside of the unit is not controlled by the unit, try to connect it to the unit. Add a 3-way valve at the fan coil inlet to guarantee a sufficient water flow.
The space heating load is small.	Normal, heating is not required.
The disinfect function is enabled but without TBH.	Deactivate the disinfect function. Add TBH for "DHW" mode.
Manually activate the "FAST DHW function, after the hot water meets the requirements, the heat pump is not able to switch to air conditioning mode in time when the air conditioner is required.	Manually deactivate the "FAST DHW" function.
When the room temperature is low, there is not enough hot water.	Set "1.9 T4DHWMIN", the suggested value is $\geq -5^{\circ}\text{C}$ . Set "1.12 T4_TBH_ON", the suggested value is $\geq -5^{\circ}\text{C}$ .
"DHW" mode priority.	If there is an IBH connected to the unit, when the hydraulic module is faulty, the unit must operate in DHW mode until the water temperature reaches the set temperature before switching to heating mode.



Symptom 8: the heat pump in "DHW" mode interrupts operation but the setpoint is not reached, space heating demands heat but the unit remains in "DHW" mode.

POSSIBLE CAUSES	CORRECTIVE ACTION
Exchange service of the DHW storage tank coil not large enough.	The same solution as for Symptom 6.
TBH not available.	The heat pump remains in DHW mode until "1.18 t_DHWHP_MAX" or the setpoint is reached. Add TBH for the DHW mode. TBH must be controlled by the unit.



### 13.3 OPERATION PARAMETERS.

This manual is intended for the installer or service engineer controlling the operating parameters.



- On the main screen, go to  > OPERATION PARAMETER.
- Press . There are nine pages of operation parameters, as indicated below. Press  and  to scroll through them.
- Press  and  to check the operation parameters of the slave units in the cascade system. The code of the address in the top right corner changes from “#00” a “#01”, “#02”, etc. Therefore:

OPERATION PARAMETER	#00
ONLINE UNITS NUMBER	1
OPERATE MODE	COOLING
SV1 STATE	ON
SV2 STATE	OFF
SV3 STATE	OFF
PUMP_I	NON
 ADDRESS	1/9 



160

OPERATION PARAMETER	#00
T5S_H.A_DHW	53°C
Tw2 CIRCUIT2 WATER TEMP.	35°C
T1S'C1 CLI. CURVE TEMP.	35°C
T1S2'C2 CLI. CURVE TEMP.	35°C
TW_OPLATE W-OUTLET TEMP.	35°C
TW_IPLATE W-INLET TEMP.	30°C
 ADDRESS	4/9 



163

OPERATION PARAMETER	#00
FAN SPEED	600 R/MIN
IDU TARGET FREQUENCY	46Hz
FREQUENCY LIMITED TYPE	5
SUPPLY VOLTAGE	230V
DC GENERATRIX VOLTAGE	420V
DC GENERATRIX CURRENT	18A
 ADDRESS	7/9 



166

OPERATION PARAMETER	#00
PUMP_O	OFF
PUMP_C	OFF
PUMP_S	OFF
PUMP_D	OFF
PIPE BACKUP HEATER	OFF
TANK BACKUP HEATER	ON
 ADDRESS	2/9 



161

OPERATION PARAMETER	#00
Tbt1 BUFFERTANK_UP TEMP.	35°C
Tbt_2 BUFFERTANK_LOW TEMP.	35°C
Tsolar	25°C
IDU SOFTWARE	01-09-2019V01
 ADDRESS	5/9 



164

OPERATION PARAMETER	#00
TW_OPLATE W-OUTLET TEMP.	35°C
TW_IPLATE W-INLET TEMP.	30°C
T2 PLATE F-OUT TEMP.	35°C
T2B PLATE F-IN TEMP.	35°C
Th COMP.SUCTION TEMP.	5°C
Tp COMP.DISCHARGE TEMP.	75°C
 ADDRESS	8/9 



167

OPERATION PARAMETER	#00
GAS BOILER	OFF
T1 LEAVING WATER TEMP.	35°C
WATER FLOW	1,72m³/h
HEAT PUMP CAPACITY	11,52kW
CONSUMPTION	1000kWh
Ta ROOM TEMP.	25°C
 ADDRESS	3/9 

162

OPERATION PARAMETER	#00
ODU MODEL	6kW
COMP. CURRENT	12A
COMP. FREQUENCY	24Hz
COMP. RUN TIME	54 MIN
COMP. TOTAL RUN TIME	1000Hrs
EXPANSION VALVE	200P
 ADDRESS	6/9 

165

OPERATION PARAMETER	#00
T3 OUTDOOR EXCHANGE TEMP.	5°C
T4 OUTDOOR AIR TEMP.	5°C
TF MODULE TEMP.	55°C
P1 COMP. PRESSURE	2300kPa
ODU SOFTWARE	01-09-2018V01
HMI SOFTWARE	01-09-2018V01
 ADDRESS	9/9 

168

 Entering the power consumption parameter is optional. Parameters not activated in the system are marked “-”.

The capacity of the heat pump is for reference only, it is not used to assess the capacity of the unit. Sensor accuracy is  $\pm 1^\circ\text{C}$ . The flow rate parameters are calculated based on the operation parameters of the pump, the deviation is different at different flow rates, the maximum deviation is 15%. The flow rate parameters are calculated based on the electric operation parameters of the pump.

The operating voltage and deviation are different.  
The value displayed is 0 when voltage is lower than 198V.

### 13.4 ERROR CODES.

When a safety device trips, an error code is displayed on the control panel (which does not include an external failure).

The table below lists all of the errors and corrective actions.

Reset the safety device by switching the unit off and back on.

If this safety device reset procedure fails, contact your local dealer.

Error Code	Supervision System Error Code	Operation anomaly or protection	Cause of fault and corrective action
E0	1	Water flow fault (after E8 has been displayed 3 times).	<ol style="list-style-type: none"> <li>1. The cable circuit is short-circuited or open. Reconnect the cable properly.</li> <li>2. The water flow rate is too low.</li> <li>3. The water flow switch is faulty, the switch opens or closes continuously, replace the water flow switch.</li> </ol>
E1	2	The phase loss or the neutral cable or the live cable are connected inversely (only for three-phase unit).	<ol style="list-style-type: none"> <li>1. Check that the power cables are connected stably, to avoid the phase loss.</li> <li>2. Check the sequence of power cables, swap any sequence of two of the three power cables.</li> </ol>
E2	3	Communication fault between the control panel and the hydraulic module.	<ol style="list-style-type: none"> <li>1. The wire between the control panel and the unit is not connected. Connect the wire.</li> <li>2. The sequence of communication cables is incorrect. Reconnect the cable in the right sequence.</li> <li>3. If there is a high magnetic field or interference with high power, such as lifts, large power transformers, etc.</li> <li>4. Add a barrier to protect the unit or move the unit to another position.</li> </ol>
E3	4	Fault of the final temperature sensor of the outlet water (T1).	<ol style="list-style-type: none"> <li>1. Check the sensor resistance.</li> <li>2. The connector of sensor T1 is loose. Reconnect it.</li> <li>3. The connector of sensor T1 is wet or there is water inside. Remove the water, dry the connector. Add waterproof adhesive.</li> <li>4. Fault of sensor T1, replace it with a new sensor.</li> </ol>
E4	5	Fault of domestic hot water storage tank temperature sensor (T5)	<ol style="list-style-type: none"> <li>1. Check the sensor resistance.</li> <li>2. The connector of sensor T5 is loose. Reconnect it.</li> <li>3. The connector of sensor T5 is wet or there is water inside. Remove the water, dry the connector. Add waterproof adhesive.</li> <li>4. Fault of sensor T5, replace it with a new sensor.</li> </ol>
E5	6	Error of the refrigerant temperature sensor exiting the condenser (T3).	<ol style="list-style-type: none"> <li>1. Check the sensor resistance.</li> <li>2. The connector of sensor T3 is loose. Reconnect it.</li> <li>3. The connector of sensor T3 is wet or there is water inside. Remove the water, dry the connector. Add waterproof adhesive.</li> <li>4. Fault of sensor T3, replace it with a new sensor.</li> </ol>

<b>Error Code</b>	<b>Supervision System Error Code</b>	<b>Operation anomaly or protection</b>	<b>Cause of fault and corrective action</b>
E6	7	Error of room temperature sensor (T4).	<ol style="list-style-type: none"> <li>1. Check the sensor resistance.</li> <li>2. The connector of sensor T4 is loose. Reconnect it.</li> <li>3. The connector of sensor T4 is wet or there is water inside. Remove the water, dry the connector. Add waterproof adhesive.</li> <li>4. Fault of sensor T4, replace it with a new sensor.</li> </ol>
E7	8	Failure of temperature sensor of inertial storage tank (Tbt1).	<ol style="list-style-type: none"> <li>1. Check the sensor resistance.</li> <li>2. The connector of sensor Tbt1 is loose. Reconnect it.</li> <li>3. The connector of sensor Tbt1 is wet or there is water inside. Remove the water, dry the connector. Add waterproof adhesive.</li> <li>4. Fault of sensor Tbt1, replace it with a new sensor.</li> </ol>
E8	9	Water flow fault.	<p>Check that all the shut-off valves of the water circuit are completely open.</p> <ol style="list-style-type: none"> <li>1. Check whether the water filter needs to be cleaned.</li> <li>2. Chap. 9.5 Filling with water.</li> <li>3. Make sure there is no air in the system (de-aeration).</li> <li>4. Check the pressure of the water. The water pressure must be &gt;1 bar.</li> <li>5. Check that the pump speed is set at the maximum speed.</li> <li>6. Make sure that the expansion vessel is not damaged.</li> <li>7. Check that the pressure drops of the hydraulic circuit are not too high for the pump (Chap. 10.4 The circulation pump).</li> <li>8. If this error occurs during defrosting (during space heating or domestic hot water heating), make sure the power supply of the backup heater is wired correctly and that the fuses are not blown.</li> <li>9. Check that the fuse of the pump and the fuse of the PCB are not blown.</li> </ol>
E9	10	Error of compressor intake temperature sensor (Th).	<ol style="list-style-type: none"> <li>1. Check the sensor resistance.</li> <li>2. The connector of sensor Th is loose. Reconnect it.</li> <li>3. The connector of sensor Th is wet or there is water inside. Remove the water, dry the connector. Add waterproof adhesive.</li> <li>4. Fault of sensor Th, replace it with a new sensor.</li> </ol>
EA	11	Error of compressor drain temperature sensor (Tp).	<ol style="list-style-type: none"> <li>1. Check the sensor resistance.</li> <li>2. The connector of sensor Tp is loose. Reconnect it.</li> <li>3. The connector of sensor Tp is wet or there is water inside. Remove the water, dry the connector. Add waterproof adhesive.</li> <li>4. Fault of sensor Tp, replace it with a new sensor.</li> </ol>
Eb	12	Error of solar panel temperature sensor (Tsolar).	<ol style="list-style-type: none"> <li>1. Check the sensor resistance.</li> <li>2. The connector of sensor Tsolar is loose. Reconnect it.</li> <li>3. The connector of sensor Tsolar is wet or there is water inside. Remove the water, dry the connector. Add waterproof adhesive.</li> <li>4. Fault of sensor Tsolar, replace it with a new sensor.</li> </ol>

Error Code	Supervision System Error Code	Operation anomaly or protection	Cause of fault and corrective action
EC	13	Error of low temperature sensor (Tbt2) of the thermostat manifold.	<ol style="list-style-type: none"> <li>1. Check the sensor resistance.</li> <li>2. The connector of sensor Tbt2 is loose. Reconnect it.</li> <li>3. The connector of sensor Tbt2 is wet or there is water inside. Remove the water, dry the connector. Add waterproof adhesive.</li> <li>4. Fault of sensor Tbt2, replace it with a new sensor.</li> </ol>
Ed	14	Error of inlet water temperature sensor (Tw_in) of plate heat exchanger.	<ol style="list-style-type: none"> <li>1. Check the sensor resistance.</li> <li>2. The connector of sensor Tw_in is loose. Reconnect it.</li> <li>3. The connector of sensor Tw_in is wet or there is water inside. Remove the water, dry the connector. Add waterproof adhesive.</li> <li>4. Fault of sensor Tw_in, replace it with a new sensor.</li> </ol>
EE	15	EEPROM fault of the main control board of hydraulic module.	<ol style="list-style-type: none"> <li>1. The EEPROM parameter is in error, rewrite the EEPROM data.</li> <li>2. The EEPROM component is damaged, replace the EEPROM component.</li> <li>3. The main control board of the hydraulic module is damaged, replace it with a new PCB.</li> </ol>
EP	19	Leakage fault on tank booster heater (TBH).	Check device connected to the TBH outputs.
P0	20	Low pressure protection switch.	<ol style="list-style-type: none"> <li>1. The system is without refrigerant volume. Charge the refrigerant at the right volume.</li> <li>2. In heating mode or in DHW mode, the external heat exchanger is dirty or something is blocked on the surface. Clean the external heat exchanger or remove the obstruction.</li> <li>3. The water flow is too low in cooling mode. Increase the water flow.</li> <li>4. The electric expansion valve is blocked or the winding connector is loose. Touch the body of the valve and connect/disconnect the connector several times to make sure that the valve works properly.</li> </ol>
P1	21	High pressure protection switch.	<p>Heating mode, DHW mode:</p> <ol style="list-style-type: none"> <li>1. The water flow is low; the temperature of the water is high, if there is air in the water system. Release the air.</li> <li>2. The water pressure is lower than 0.1 MPa, load the water to leave the pressure in the range 0.15-0.2 MPa.</li> <li>3. Refrigerant volume overload. Recharge the refrigerant at the right volume.</li> <li>4. The electric expansion valve is blocked or the winding connector is loose. Touch the body of the valve and connect/disconnect the connector several times to make sure that the valve works properly. Also install the winding in the right position. DHW mode: The storage tank coil is small.</li> </ol> <p>Cooling mode:</p> <ol style="list-style-type: none"> <li>1. The protection of the heat exchanger has not been removed. Remove the protection.</li> <li>2. The heat exchanger is dirty or something is blocked on the surface. Clean the heat exchanger or remove the obstruction.</li> </ol>

Error Code	Supervision System Error Code	Operation anomaly or protection	Cause of fault and corrective action
P3	23	Protection against compressor overcurrent.	<ol style="list-style-type: none"> <li>1. The same reason as for P1.</li> <li>2. The supply voltage of the unit is low, increase the supply voltage to the required range.</li> </ol>
P4	24	Protection against flow temperature of the compressor too high	<ol style="list-style-type: none"> <li>1. The same reason as for P1.</li> <li>2. The system is without refrigerant volume. Charge the refrigerant at the right volume.</li> <li>3. The sensor Tw_out temp. is loose. Reconnect it.</li> <li>4. The sensor T1 temp. is loose. Reconnect it.</li> <li>5. The sensor T5 temp. is loose. Reconnect it.</li> </ol>
P5	25	High temperature difference between water inlet and water outlet of the plate heat exchanger. (Tw_out-Tw_in)	<ol style="list-style-type: none"> <li>1. Check that all the shut-off valves of the water circuit are completely open.</li> <li>2. Check whether the water filter needs to be cleaned.</li> <li>3. Chap. 9.5 Filling with water.</li> <li>4. Make sure there is no air in the system (de-aeration).</li> <li>5. Check the pressure of the water. The water pressure must be &gt;1 bar (with cold water).</li> <li>6. Check that the pump speed is set at the maximum speed.</li> <li>7. Make sure that the expansion vessel is not damaged.</li> <li>8. Check that the pressure drops of the hydraulic system are not too high for the pump (Chap. 10.4 The circulation pump).</li> </ol>
P6	26	Inverter module protection.	<ol style="list-style-type: none"> <li>1. The supply voltage of the unit is low, increase the supply voltage to the required range.</li> <li>2. The space between the units is too narrow for the thermal exchange. Increase the space between the units.</li> <li>3. The heat exchanger is dirty or something is blocked on the surface. Clean the heat exchanger or remove the obstruction.</li> <li>4. The fan does not work. The motor of the fan or the fan is damaged, replace it with a new fan or a new motor.</li> <li>5. Refrigerant volume overload. Recharge the refrigerant at the right volume.</li> <li>6. The water flow rate is low, there is air in the system, or the pump head is not sufficient. Release the air and select the pump again.</li> <li>7. The outlet water temperature sensor is loose or damaged; reconnect it or replace it with a new one.</li> <li>8. The storage tank coil is small.</li> <li>9. The wiring of the module or the screws are loose. Reconnect the wires and screws. The thermally conductive adhesive is dry or shifted. Add some thermally conductive adhesive.</li> <li>10. The connection of the cables is loose or failed. Reconnect the cable.</li> <li>11. The drive board is faulty, replace it with a new one.</li> <li>12. If it already has been confirmed that the control system has no problems, then the compressor is faulty. Replace it with a new compressor.</li> </ol>

Error Code	Supervision System Error Code	Operation anomaly or protection	Cause of fault and corrective action
P9	29	Fan protection.	Check the condition of the fan and of the fan motor.
Pb	31	Antifreeze protection.	The unit automatically returns to normal operation.
Pd	33	High temperature protection of the outlet temperature of the refrigerant in the condenser.	<ol style="list-style-type: none"> <li>1. The protection of the heat exchanger has not been removed. Remove the protection.</li> <li>2. The heat exchanger is dirty or something is blocked on the surface. Clean the heat exchanger or remove the obstruction.</li> <li>3. There is not enough space around the unit for thermal exchange.</li> <li>4. The fan motor is damaged, replace it with a new one.</li> </ol>
PP	38	The inlet water temperature is higher than the water outlet in heating mode. ( $T_{w\_in} > T_{w\_out}$ )	<ol style="list-style-type: none"> <li>1. Check the resistance of the two sensors.</li> <li>2. Check the two positions of the sensors.</li> <li>3. The connector of the cable of the water inlet/outlet sensor is loose. Reconnect it.</li> <li>4. The water inlet/outlet sensor (<math>T_{w\_in}/T_{w\_out}</math>) is damaged. Replace it with a new sensor.</li> <li>5. The four-way valve is blocked. Restart the unit to allow the valve to change direction.</li> <li>6. The four-way valve is damaged, replace it with a new valve.</li> </ol>
H0	39	Communication fault between the main control board of the hydraulic module and the main control board PCB B.	<ol style="list-style-type: none"> <li>1. The cable does not connect the main control board PCB B and the main control board of the hydraulic module. Connect the cable.</li> <li>2. The sequence of communication cables is incorrect. Reconnect the cable in the right sequence.</li> <li>3. If there is a high magnetic field or interference due to high power, such as lifts, large power transformers, etc. Add a barrier to protect the unit or move the unit to another position.</li> </ol>
H1	40	Communication error between the inverter module PCB A and the main control board PCB B.	<ol style="list-style-type: none"> <li>1. Check whether the two boards PCB A (inverter module) and PCB B (control board) are powered. Check whether the indicator light on the printed circuit of the inverter is on or off. If the light is off, reconnect the power cable.</li> <li>2. If the light is on, check the wiring connection between the PCB of the inverter module and the PCB of the main control board. If wiring is loose or damaged, reconnect the wiring or change with new wiring.</li> <li>3. Replace the main board (PCB B) and then the inverter module (PCB A).</li> </ol>
H2	41	Fault of outlet temperature sensor (T2) of refrigerant from the plate heat exchanger (liquid pipe).	<ol style="list-style-type: none"> <li>1. Check the sensor resistance.</li> <li>2. The connector of sensor T2 is loose. Reconnect it.</li> <li>3. The connector of sensor T2 is wet or there is water inside. Remove the water and dry the connector. Add waterproof adhesive.</li> <li>4. Fault of sensor T2, replace it with a new sensor.</li> </ol>



Error Code	Supervision System Error Code	Operation anomaly or protection	Cause of fault and corrective action
H3	42	Fault of outlet temperature sensor (T2B) of refrigerant from the plate heat exchanger (gas pipe).	<ol style="list-style-type: none"> <li>1. Check the sensor resistance.</li> <li>2. The connector of sensor T2B is loose. Reconnect it.</li> <li>3. The connector of sensor T2B is wet or there is water inside. Remove the water and dry the connector. Add waterproof adhesive.</li> <li>4. Fault of sensor T2B, replace it with a new sensor.</li> </ol>
H4	43	Protection for three times P6 (L0/L1)	The total number of times in which L0 and L1 appear in an hour is equal to three. See L0 and L1 for the fault management methods.
H5	44	Fault of room temperature sensor (Ta).	<ol style="list-style-type: none"> <li>1. Check the sensor resistance.</li> <li>2. The sensor Ta is in the control panel.</li> <li>3. Fault of sensor Ta, replace with a new sensor or switch to a new panel, or reset Ta, connect a new Ta from the hydraulic module PCB.</li> </ol>
H6	45	Fault of fan motor.	<ol style="list-style-type: none"> <li>1. Strong wind towards the fan, turn the fan in the opposite direction. Change the direction of the unit or create a guard to prevent the wind from going towards the fan.</li> <li>2. The fan motor is damaged, replace it with a new motor.</li> </ol>
H7	46	Main circuit voltage protection fault.	<ol style="list-style-type: none"> <li>1. If the power supply input is within the available range.</li> <li>2. Switch on and off several times quickly and in a short amount of time. Keep the unit off for more than 3 minutes after ignition.</li> <li>3. The part of the circuit of the main control board is faulty. Replace with a new main PCB.</li> </ol>
H8	47	Fault of pressure sensor.	<ol style="list-style-type: none"> <li>1. The connector of the pressure sensor is loose, reconnect it.</li> <li>2. Fault of pressure sensor. Replace it with a new sensor.</li> </ol>
H9	48	Fault of zone 2 flow temperature sensor (Tw2).	<ol style="list-style-type: none"> <li>1. Check the sensor resistance.</li> <li>2. The connector of sensor Tw2 is loose. Reconnect it.</li> <li>3. The connector of sensor Tw2 is wet or there is water inside. Remove the water, dry the connector. Add waterproof adhesive.</li> <li>4. Fault of sensor Tw2, replace it with a new sensor.</li> </ol>
HA	49	Fault of outlet water temperature sensor (Tw_out).	<ol style="list-style-type: none"> <li>1. Check the sensor resistance.</li> <li>2. The connector of sensor Tw_out is loose. Reconnect it.</li> <li>3. The connector of sensor Tw_out is wet or there is water inside. Remove the water, dry the connector. Add waterproof adhesive.</li> <li>4. Fault of sensor Tw_out, replace it with a new sensor.</li> </ol>
Hb	50	Protection "PP" three times and Tw_out < 7°C	The same applies for "PP"

Error Code	Supervision System Error Code	Operation anomaly or protection	Cause of fault and corrective action
Hd	52	Communication fault between hydraulic module in parallel.	<ol style="list-style-type: none"> <li>1. The signal wires of the slave units and of the master unit are not connected effectively. After having checked that all the signal wires are properly connected, and having made sure that there is no strong electricity or strong magnetic interferences, switch the unit back on.</li> <li>2. There are two or more outdoor units connected to the control panel. After having removed the extra control panel and having kept only the control panel of the master unit, switch the unit back on.</li> <li>3. The ignition interval between the master unit and the slave unit is longer than 2 minutes. After having made sure that the interval between ignition of all the master units and slave units is less than 2 minutes, switch the unit back on.</li> <li>4. The addresses of the master units and of the slave units are repeated; pressing the key SW2 on the main board of the slave units once, the address code of the slave unit will be displayed (Normally address code, one of 1,2,3 ... 15 will be displayed on the main board), check whether it is a duplicate of the address. If there is a duplicated address code, after having switched the system off, set S4-1 at ON on the main board of the master unit or on the main board of the slave unit displaying the error "Hd" (refer to Chap. 10.1.1 Setting of the function). Switch all the units back on for 5 minutes without error "Hd", switch back off and set S4-1 at OFF. The system is reset.</li> </ol>
HE	53	Communication error between main board and thermostat transfer board.	The control board RT/Ta PCB is set to be valid on the control panel but the thermostat transfer board is not connected or communication between the thermostat transfer board and the main board is not actually connected. If the transfer board of the thermostat is not necessary, set RT/Ta PCB at not active. If the transfer board of the thermostat is necessary, connect it to the main board and make sure that the communication wire is properly connected and that there are no strong electricity or strong magnetic interferences.
HF	54	EEPROM fault of the inverter module board.	<ol style="list-style-type: none"> <li>1. The EEPROM parameter is in error, rewrite the EEPROM data.</li> <li>2. The EEPROM component is damaged, replace the EEPROM component.</li> <li>3. The module board of the inverter is damaged, replace it with a new PCB.</li> </ol>
HH	55	H6 appeared 10 times in 2 hours.	See H6.
HP	57	Low pressure protection in cooling $P_e < 0.6$ occurred 3 times in one hour.	See P0.

Error Code	Supervision System Error Code	Operation anomaly or protection	Cause of fault and corrective action
C7	65	Temperature of transducer module too high.	<ol style="list-style-type: none"> <li>1. The supply voltage of the unit is low, increase the supply voltage to the required range.</li> <li>2. The space between the units is too narrow for the thermal exchange. Increase the space between the units.</li> <li>3. The heat exchanger is dirty or something is blocked on the surface. Clean the heat exchanger or remove the obstruction.</li> <li>4. The fan does not work. The motor of the fan or the fan is damaged, replace it with a new fan or a new motor.</li> <li>5. The water flow rate is low, there is air in the system, or the pump head is not sufficient. Release the air and select the pump again.</li> <li>6. The outlet water temperature sensor is loose or damaged; reconnect it or replace it with a new one.</li> </ol>
F1	116	Low voltage protection on DC bus.	<ol style="list-style-type: none"> <li>1. Check power supply.</li> <li>2. If the power supply is OK, check whether the LED light is OK, check whether PN voltage is 380V, the problem usually comes from the main board. Furthermore, if the light is OFF, disconnect power, check the IGBT, check the diodes. If voltage is not correct or the inverter board is damaged, change it.</li> <li>3. If there is no problem with IGBT, it means that there are problems on the board of the inverter. Check the rectifier link. (Same method as IGBT: disconnect power, check whether or not the diodes are damaged).</li> <li>4. Usually, if F1 is displayed when the compressor is started, it likely depends on the main board. If F1 appears when the fan is started, it could be due to the board of the inverter.</li> </ol>
L0	134	Compressor inverter module fault.	<ol style="list-style-type: none"> <li>1. Check the pressure of the heat pump system.</li> <li>2. Check the phase resistance of the compressor.</li> <li>3. Check the connection sequence of the power line U, V, W between the inverter board and the compressor.</li> <li>4. Check the connection of the power line L1, L2, L3 between the inverter board and the filter board.</li> <li>5. Check the board of the inverter.</li> </ol>
L1	135	Low voltage protection on DC bus.	
L2	136	High voltage protection on DC bus.	
L4	138	MCE operation anomaly.	
L5	139	Zero speed protection.	
L7	141	Phase sequence fault (only three-phase models).	
L8	142	Frequency variation of compressor higher than 15Hz within 1 second.	
L9	143	The actual frequency of the compressor differs from the target frequency by over 15Hz.	

# 14 TECHNICAL SPECIFICATIONS.

## 14.1 GENERAL.

### Models 4-16kW.

	Single-phase	Single-phase	Three phase
	4/6kW	8kW	12/14/16kW
Nominal capacity	Chap.technical data		
Dimensions HxWxD	718x1295x426 mm	865x1385x523 mm	865x1385x523 mm
Package dimensions HxLxP	885x1375x475 mm	1035x1465x560 mm	1035x1465x560 mm
Minimum flow rate	0.40 m <sup>3</sup> /h	0.40 m <sup>3</sup> /h	0.70 m <sup>3</sup> /h
Maximum flow rate	4kW: 0.90 m <sup>3</sup> /h 6kW: 1.25 m <sup>3</sup> /h	1.65 m <sup>3</sup> /h	12kW: 2.50 m <sup>3</sup> /h
			14kW: 2.75 m <sup>3</sup> /h
			16kW: 3.00 m <sup>3</sup> /h
<b>Weight</b>			
Net weight	91 kg	110 kg	149 kg
Gross weight	112 kg	137 kg	177 kg
<b>Connections</b>			
Water inlet/outlet	G1" BSP	G1 1/4" BSP	G1 1/4" BSP
Water drain	Fitting for flexible hose		
<b>Expansion vessel</b>			
Volume	8 L		
Maximum working pressure (MWP)	8 bar		
<b>Pump</b>			
Type	Fixed speed		
<b>Internal watervolume (1 bar ~ 3 bar)</b>			
3kW (backup heater)	3.3 ~ 8.1L	3.6 ~ 8.4L	N/A
9kW (backup heater)	N/A	N/A	3.8 ~ 8.6L
Water circuit pressure relief valve	3 bar		
<b>Operation range - water side</b>			
Central heating	+12 ~ +65°C		
Cooling	+5 ~ +25°C		
<b>Operation range - air side</b>			
Central heating	-25 ~ +35°C		
Cooling	-5 ~ +43°C		
Domestic hot water with heat pump	-25 ~ +43°C		

## 14.2 ELECTRICAL TECHNICAL SPECIFICATIONS.

### Models 4-16kW.

	4kW	6kW	8kW	12kW T	14kW T	16kW T
Power supply	220-240V ~ 50Hz			380-415V 3N ~ 50Hz		
Input power	2.3kW + 3kW (*)	2.7kW + 3kW (*)	3.4kW + 3kW (*)	5.5kW + 9kW (*)	5.8kW + 9kW (*)	6.2kW + 9kW (*)
Rated operating current	25 A	27 A	29 A	23 A	24 A	25 A

\* Internal backup heater.

# 15 INFORMATION ON MAINTENANCE.

## 1. Checks in the area.

Before starting work on systems containing flammable refrigerants, safety checks must be performed to guarantee that the risk of flammability is reduced to a minimum. Before performing repairs on chilling systems, follow the precautions below.

## 2. Work procedure.

The jobs must be carried out according to a consolidated safety procedure to reduce the risk of refrigerant or flammable vapour leaks during work to a minimum.

## 3. Work area.

All maintenance personnel and anyone else working in the involved area must be informed as to the nature of the work carried out. Avoid working in confined spaces. The area in the immediate vicinity of the work field must be appropriately delimited. Make sure that there are safety conditions within the area to prevent the risk of refrigerant leaks.

## 4. Refrigerant leak check.

The area must be checked with an adequate refrigerant detector before and during the jobs, to guarantee that the technician is aware of the presence of potentially flammable atmospheres. Make sure that the leak detector is suitable to be used with flammable refrigerants, namely without electric discharges, appropriately sealed or inherently safe.

## 5. Presence of a fire extinguisher.

If hot work needs to be done on the chilling system or on related parts, adequate firefighting devices must be available. Check that there is a dry fire extinguisher or a CO<sub>2</sub> fire extinguisher adjacent to the recharge area.

## 6. No source of ignition.

No one carrying out work in relation to a chilling system that entails exposure of pipes that contain or have contained flammable refrigerant must use sources of ignition implicating the risk of fire or explosion. All possible sources of ignition, including cigarette embers, must be kept sufficiently far from the place of installation, repair, removal and disposal, during which the flammable refrigerant could be released into the surrounding area. Before starting the work, the area around the appliance must be monitored to make sure there are no flammability hazards or ignition risks.

“NO SMOKING” signs must be applied.

## 7. Ventilated area.

Make sure that the area is outdoors or appropriately ventilated before entering it or performing hot work. A certain ventilation level must also be guaranteed while carrying out the work. Ventilation must safely release the dispersed refrigerant and preferably eject it into the outside atmosphere.

## 8. Checks on the chilling equipment.

When replacing electric components, these must be suitable for the purpose for which they are used and comply with the correct specifications. The manufacturer’s guidelines for maintenance and service must be complied with that all times. Should any doubts arise, contact the Authorised Immergas Technical Service for assistance. The following controls must be applied to systems that make use of flammable refrigerants:

- The recharging amount depends on the size of the room where the appliances containing the refrigerant are installed;
- Ventilation devices must run regularly and the ejection routes must not be obstructed;
- Illegible markings or writings must be corrected.
- Chilling lines or refrigeration components must be installed in a position where they are unlikely to be exposed to any substance that can corrode components containing refrigerants, unless the components themselves are made of materials inherently resistant to corrosion or have been adequately protected against corrosion.

## 9. Checks on electrical devices.

Repair and maintenance operations on electric components must include preventive safety checks and inspection procedures of the components. If a fault occurs that could jeopardise safety, the circuit must not be powered until the issue has been resolved in a satisfactory way. If it is not possible to immediately eliminate the fault, but the system needs to keep running, a temporary solution must be found. This must be communicated to the owner of the equipment so that all parties are informed thereof.

The initial safety checks include making sure:

- That the capacitors are discharged: this is essential to avoid the possibility of electrical discharges;
- That there are no live components or cables during charging, recovery or purging of the circuit;
- That a compliant earthing system is in place.

## 10. Repair of sealed components.

- a) During repairs of sealed components, all power supplies must be disconnected from the appliance in operation before removing the sealed covers, etc. If it is absolutely necessary that the appliance be energised during maintenance, a permanently operated leak detection device must be used, at the most critical point, to prevent a potentially hazardous situation.
- b) Special attention must be paid to the following to make sure that, while working on electric components, the enclosure is not changed in such a way as to alter the protection level. This includes damage to cables, an excessive number of connections, terminals non-conforming to the original specifications, damage to gaskets, incorrect assembly of cable glands, etc.
  - Check that the appliance is installed appropriately.
  - Make sure that the gaskets or sealing materials are not degraded to such a point that flammable atmospheres may enter. The spare parts must comply with the specifications of the manufacturer.



The use of silicone sealant could inhibit the effectiveness of some types of leak detection equipment. Inherently safe components must not be isolated before working on them.

#### 11. Repair of inherently safe components.

Do not apply permanent inductive or capacitive loads to the circuit without first having checked that they do not exceed the voltage and current allowed for the instruments in use. Inherently safe components are the only ones on which it is possible to work when live in the presence of a flammable atmosphere. The test equipment must be correctly classified. Only replace the components with others indicated by the manufacturer. The use of other components could trigger refrigerant flammability following a leak into the atmosphere.

#### 12. Wiring.

Check that wiring is not subject to wear, corrosion, excessive pressure, vibrations, sharp edges or other adverse environmental effects. The check must also take into consideration the consequences of aging or of continuous vibrations coming from sources such as compressors or fans.

#### 13. Detection of flammable refrigerants.

Under no circumstances must potential sources of ignition be used to look for or detect refrigerant leaks. Halide torches (or any other detector that uses naked flames) must not be used.

#### 14. Leak detection methods.

The following leak detection methods are deemed acceptable for systems containing flammable refrigerants. Electronic leak detectors must be used to detect flammable refrigerants, but their sensitivity might not be adequate or require recalibration. (The detection device must be calibrated in an area free of refrigerants). Make sure that the detector is not a potential source of ignition and that it is suitable for the refrigerant. The leak detection appliance must be set at an LFL percentage of the refrigerant and calibrated for the refrigerant used; the appropriate percentage of gas is confirmed (25% at maximum). Leak detection fluids can be used with the majority of refrigerants, but detergents containing chlorine must not be used as this element can react with the refrigerant and corrode the copper pipes. If there is a suspected leak, all naked flames must be removed or put out.

#### 15. Removal and discharge.

When interacting on the refrigerant circuit to perform repairs or for any other purpose, conventional procedures must be followed. It will be important to abide by consolidated practice as flammability is a very important factor to be taken into consideration. The following procedure must be complied with:

- Remove the refrigerant;
- Purge the circuit with inert gas;
- Discharge;
- Purge again with inert gas;
- Restore the circuit by cutting or performing a brazing intervention.

The refrigerant charge must be recovered in appropriate recovery cylinders. The circuit must be washed with nitrogen to remove impurities from the appliance. This process might need to be repeated several times.

Compressed air or oxygen must not be used for this activity.

Make sure that the vent of the vacuum pump is not exposed to triggering sources with a simultaneous ventilation source.

#### 16. Charging procedure.

In addition to conventional charging procedures, the following requirements must be complied with:

- Make sure that different refrigerant contaminations do not occur when using recharging equipment. The tubes or pipes must be as short as possible to minimise the amount of refrigerant therein.
- The cylinders must be upright.
- Make sure that the chilling system is earthed before charging the system with refrigerant.
- Label the circuit when the charge is complete (unless this has already been done).
- Pay the utmost attention not to subsequently fill the chilling circuit.
- Before recharging the circuit, it must undergo a pressurised leak test with nitrogen.

#### 17. Deactivation.

Before performing this operation, the technician must have extensive knowledge of the appliance and all its details. It is good practice that the refrigerant be recovered correctly. Before performing the intervention, an oil and refrigerant sample must be withdrawn.

If an analysis needs to be performed before recovering the refrigerant, power must be available.

- a) Become acquainted with the appliance and its operation.
- b) Disconnect power to the product.
- c) Before starting the activity, proceed as follows:
  - Ascertain, where necessary, the availability of mechanical equipment to handle the refrigerant cylinders.
  - Check that personal protective equipment is available and used correctly.
  - Make sure that the recovery operation is supervised at all times by a skilled person.
  - The equipment and the recovery cylinders comply with current regulations.
- d) Empty the chilling circuit by means of the specific service ports.
- e) If it is not possible to discharge the circuit by means of the specific service ports, make a “manifold” so that the refrigerant can be removed from other points of the system.
- f) Make sure that the cylinder is placed on the scale before proceeding with recovery.
- g) Start the recovery machine and follow the instructions given by the manufacturer.
- h) Do not overfill the cylinders. (Do not exceed 80% of the charge volume of the liquid).
- i) Do not exceed the maximum working pressure of the cylinder, not even temporarily.
- j) When the cylinders have been filled to the maximum capacity and the intervention has been completed, make sure that these and the equipment are immediately removed from the area and that all shut-off valves on the equipment are closed.
- k) The recovered refrigerant cannot be recharged into another chilling system unless it has been regenerated and controlled.

#### 18. Labelling.

The appliance must be labelled with an indication that it has been decommissioned and the refrigerant emptied. The label must be dated and signed. Make sure that there are labels on the appliance indicating that it contains flammable refrigerant.

#### 19. Recovery.

When refrigerant is removed from a system, both for maintenance operations and deactivation, good practice is recommended to remove the refrigerant correctly.

When the refrigerant is transferred to cylinders, make sure that only adequate cylinders for recovery of refrigerant are used. Make sure that a proportionate number of cylinders is available for storage of the total charge of the system. All the cylinders to be used are specifically dedicated for the recovered refrigerant and labelled accordingly (namely they are specific cylinders for refrigerant recovery). The cylinders must have a pressure relief valve and relative shut-off valves in good working conditions.

The recovery cylinders must be in vacuum and, if possible, cooled before the recovery operation.

The recovery equipment must be in good working order with relative instructions close at hand and it must also be suitable for the recovery of flammable refrigerants. Lastly, a series of calibrated scales must be available and in good working order.

The flexible hoses must be complete with shut-off valves without leaks and in good conditions. Before using the recovery instrument, check that it is in satisfactory operating conditions, that maintenance has been performed correctly and all the associated electric components have been sealed to avoid an accidental ignition in case of a refrigerant leak. Contact the manufacturer in case of doubts.

The recovered refrigerant must be returned to the refrigerant supplier in the appropriate recovery cylinder and the relative waste transfer note must be drafted. Do not mix refrigerants in recovery units and above all not inside the cylinders. Should it be necessary to remove compressors or oil for compressors, make sure that they have been emptied sufficiently to guarantee that no flammable refrigerant remains inside the lubricant. The emptying procedure must be carried out before returning the compressor to the supplier. To speed up this operation, only electrical heating should be used on the body of the compressor. When oil is discharged from a system, the operation must be performed safely.

#### 20. Transport, marking and storage of the appliances.

Transportation of equipment containing flammable refrigerants (Conformity with transport standards).

Marking of equipment with signs (Conformity with local standards).

Disposal of equipment using flammable refrigerants (Conformity with national standards).

Storage of equipment/appliances.

The appliances must be stored in compliance with the instructions of the manufacturer.

Storage of packaged equipment (unsold).

The protection of the storage packaging must be built in such a way that any mechanical damage to the equipment inside the packaging does not cause a leak of the refrigerant charge.

The maximum number of appliances that can be stored together will be determined by local regulations.

## 15.1 ATTACHMENTS

### ANNEX A: Refrigerant cycle Units 4-16kW.

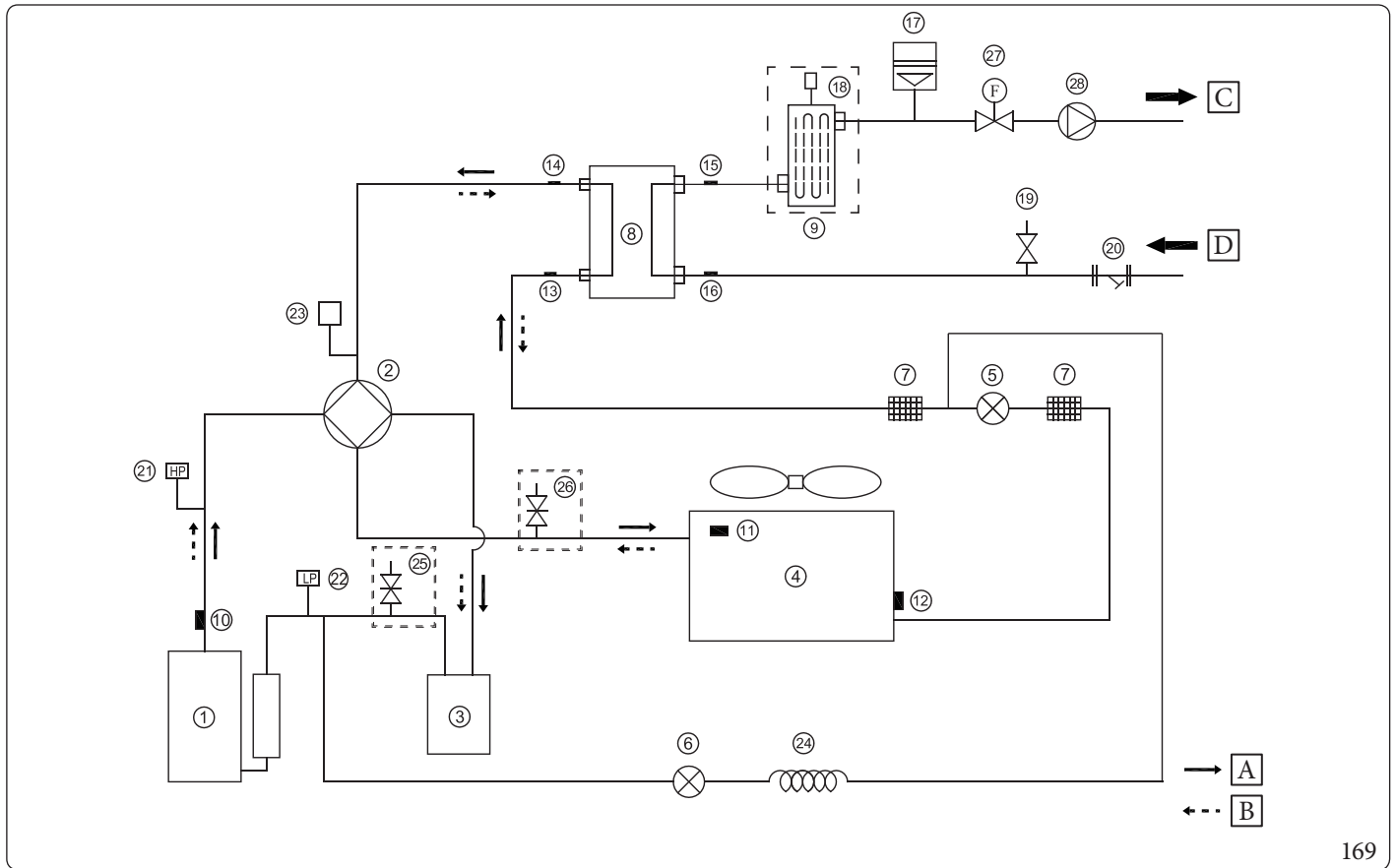

169

Pos.	Description	Pos.	Description
1	Compressor	17	Expansion vessel
2	4-way valve	18	Automatic air purge valve
3	Gas- liquid separator	19	Pressure relief valve
4	Air side heat exchanger	20	Y-filter
5	Electronic expansion valve	21	High pressure switch
6	One-way magnetic valve	22	Low pressure switch
7	Filter	23	Pressure sensor
8	Water side heat exchanger (Plate heat exchanger)	24	Capillary
9	Backup heater	25	Needle valve for recharging refrigerant gas ( <b>ONLY ON Unit 4 -6kW</b> )
10	Discharge gas sensor	26 *	Needle valve for recharging refrigerant gas ( <b>ONLY ON Unit 8 -16kW</b> )
11	Outdoor temperature sensor	27	Flow switch
12	Heating evaporation sensor (Cooling condenser sensor)	28	Circulation pump
13	Refrigerant inlet temperature sensor (liquid pipe)	A	Cooling
14	Refrigerant outlet temperature sensor (gas pipe)	B	Central heating
15	Water outlet temperature sensor	C	Outlet
16	Water inlet temperature sensor	D	Inlet

(\*) = Make a heating demand to complete the recharge of the refrigerant gas.



**ANNEX B: Installation of additional electric heating cable on drainage pipe (optional not supplied by Immergas)**



Connect the electrical heating cable, on the drainage pipe, to terminal board XT3.



Images are for reference purposes only; please refer to the actual product.  
The power supply of the heating cable will not exceed 40W/200mA, supply voltage 230Vac.

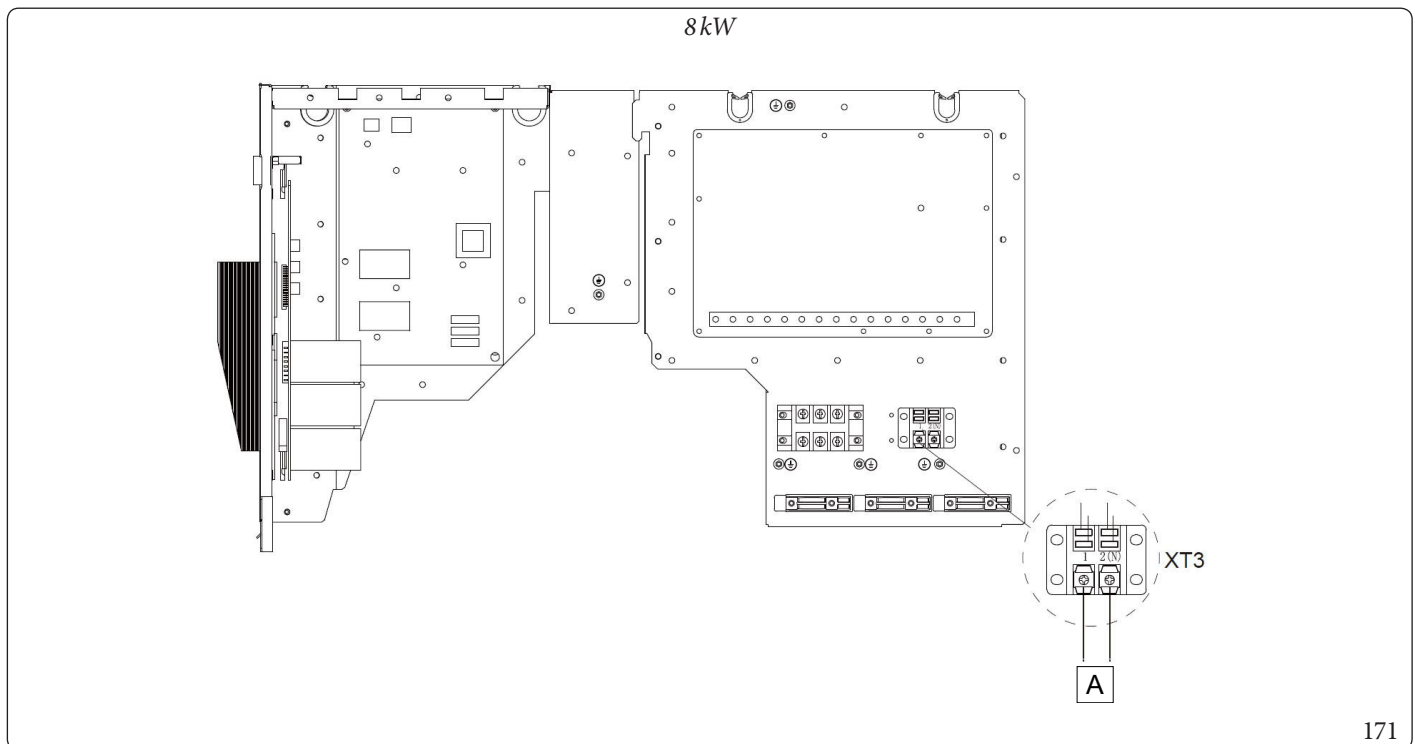
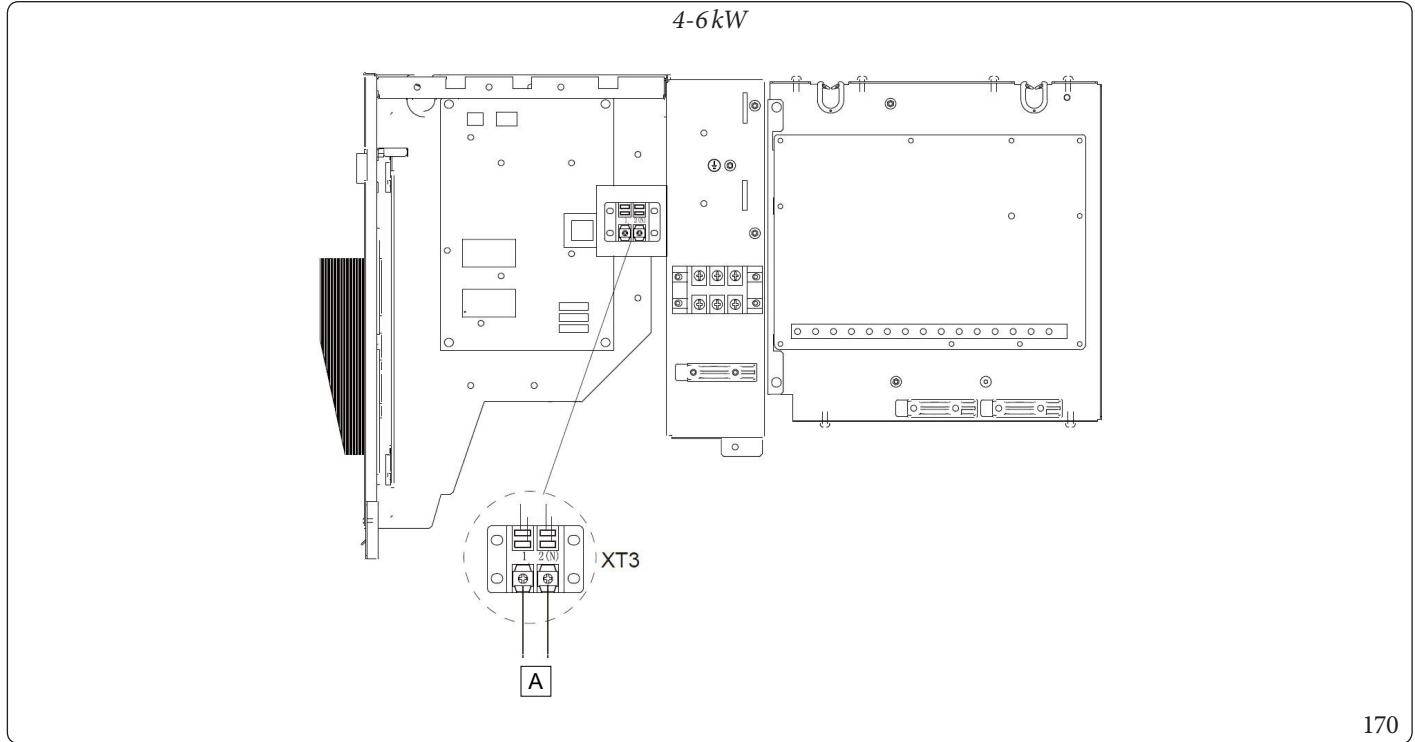

Key (Fig. 170, 171):

A - At the drain outlet heating belt

12-14-16kW (Three phase)

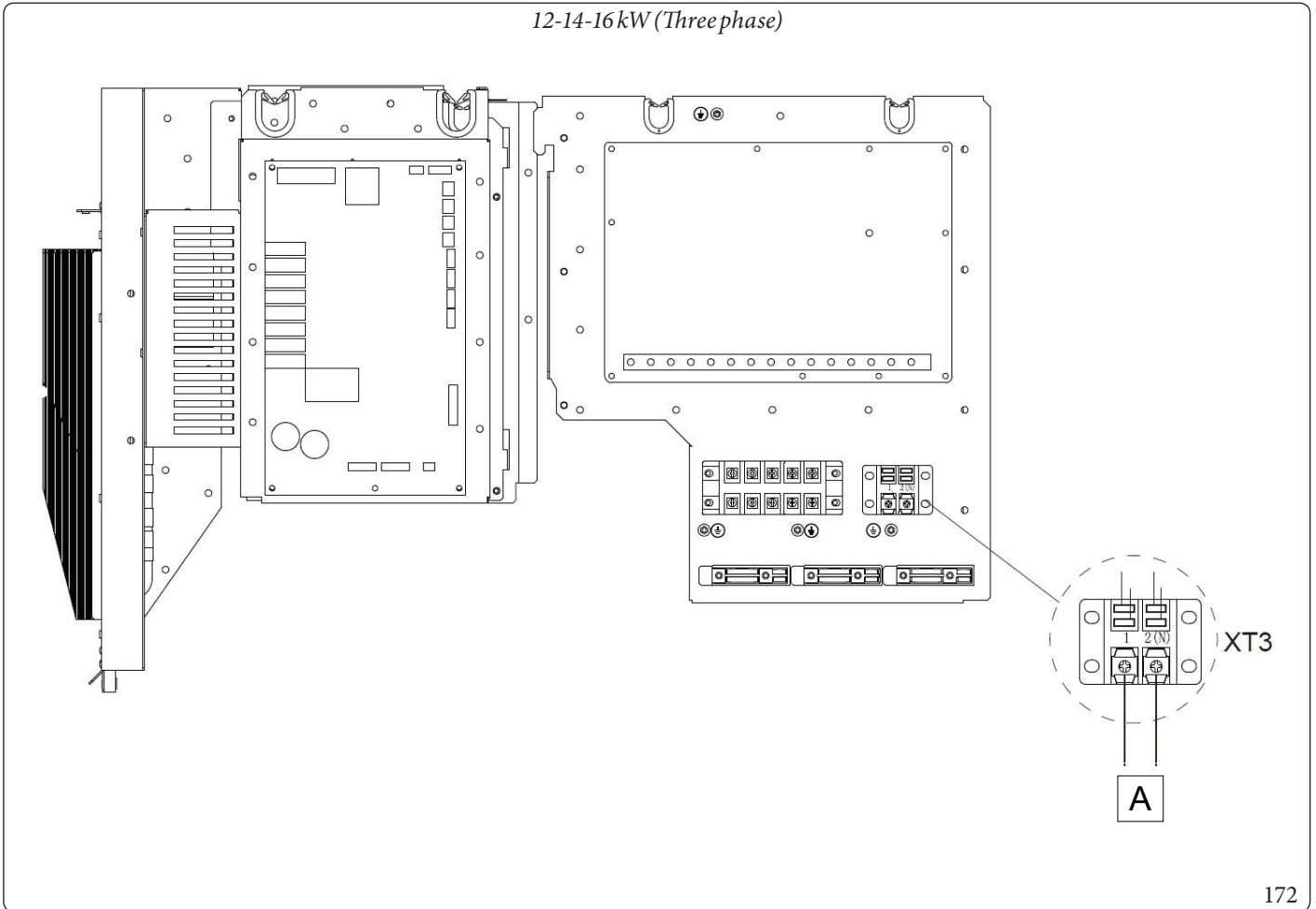

Key (Fig. 172):

A - At the drain outlet heating belt





This instruction booklet is made of ecological paper.

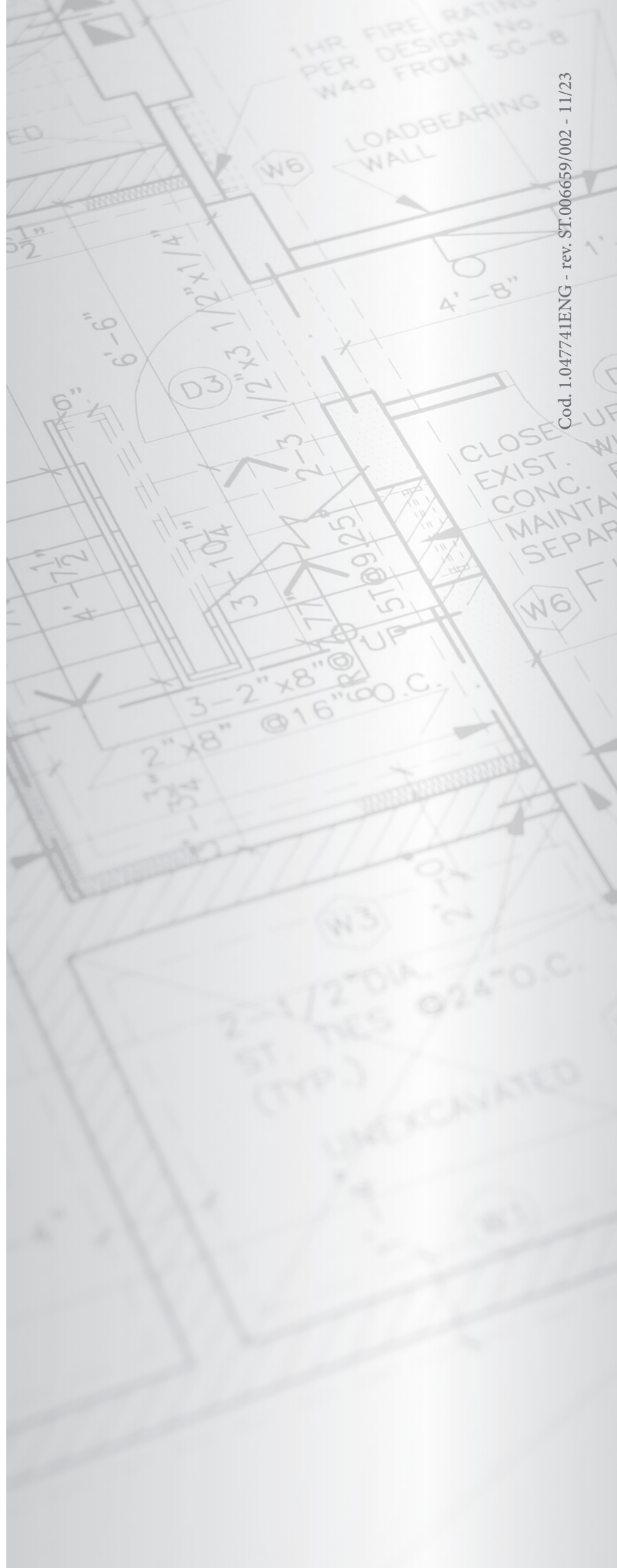

Cod. 1.04774IENG - rev. ST.006659/002 - 11/23



[immergas.com](http://immergas.com)

Immergas S.p.A.  
42041 Brescello (RE) - Italy  
Tel. 0522.689011  
Fax 0522.680617