

ALTA POTENZA

IMMERGAS

VICTRIX PRO V2 EU

High power, wall-hung
condensation boilers



TECHNICAL SHEET

VICTRIX PRO V2 EU



VICTRIX PRO V2 EU is the new range of wall-hung condensing boilers for room heating only, set-up for independent functioning and for set configuration (up to 5 appliances with a single safety devices kit), with the advantage of guaranteeing higher overall output and reduced running costs. All models can be installed both inside and outside, on the wall, on a bearing frame or inside specific technical cabinets. This gives the designer and installer a variety of solutions to adapt the technological systems according to the building context.

The high heat output extension of VICTRIX PRO V2 EU is ideal for central heating with large domestic systems (duplexes, three-unit houses, condominiums), as well as commercial and industrial applications.

The new combustion system connected to the boiler's electronics provides a broader range of output modulation, between 10% and 100%, therefore streamlining boiler operation, also through reduced heat load requests (for example during spring and autumn or when the system is only partially used). Designed to operate with new gas mixtures (methane + 20% hydrogen) further reducing atmospheric pollution.

The ecological burners guarantee particularly reduced polluting emissions (the boilers belong to the most environment-friendly class envisioned by European Standards - class 6).

The new low consumption modulating pumps change their speed to check ΔT between the flow and return and, consequently, reduce power consumption and guarantee total silence during operation.

With single boiler installation, an external 3-way valve can be connected for coupling to a separate storage tank unit (such as

Immergas 300, 500, 1000, 1500 and 2000 litre storage tank unit).

When operating in set configuration, even exploiting simple cascade without using the cascade and zone regulator kit, it is possible to hydraulically couple up to 5 appliances with a single safety device kit, making it extremely easy to provide the required output size for the specific heat system.

A wide range of optional hydraulic kits, flue systems, temperature control and accessories are also available to tackle many practical situations, promoting the sales proposal.

VICTRIX PRO V2 EU (with the exception of mod. 180) can also be installed on a specific modular supporting frame which offers single or set installation (up to 5 modules), in linear set-up, or back-to-back for more limited spaces. The frame has supporting collars for the hydraulic manifolds and can be attached to the wall or floor with plugs. Thanks to a specific surface treatment, the support frame is also type-approved for outdoor installation, open-air. It can also be installed inside a containment cabinet kit suitable for outdoor open-air installation, again with the exception of VICTRIX PRO V2 180 EU, coupled to specific optional kits.

By purchasing more cabinets, it is also possible to develop set configurations up to 5-generators.

VICTRIX PRO V2 EU

1

NEW HIGH-POWER RANGE SPECIFICATIONS



The updated VICTRIX PRO V2 EU range, today available in 9 output sizes (35 - 55 - 60 - 68 - 80 - 100 - 120 - 150 - 180) instead of the previous 6, and the large number of optionals, make the technical and commercial offer of products especially interesting. The following are the highlights of the PRO V2 EU range:

- Generators built to work with new methane-hydrogen mixtures, capable of reducing polluting emissions for the surrounding environment and the greenhouse effect to a minimum;
- High seasonal performance and modulation range of the extremely wide heat output;
- Installation flexibility both in the heating control unit and outdoors;
- Installation in technical cabinet (except for model VICTRIX PRO V2 180 EU);
- Installation on specific support frames (except for model VICTRIX PRO V2 180 EU);
- High modularity, also thanks to the electronics that allow you to control up to 15 modules in simple cascade;
- Make heat output systems higher than MW, with reduced size;
- A particularly rich supply of optionals
- Updated electronics with dialogue for BMS.

Wall-hung, sealed-chamber and fan-assisted pre-mixed condensing modules, high efficiency with forced circulation, with variable useful power outputs:

VICTRIX PRO V2 35 EU = 33,9 kW - 3,7 kW;

VICTRIX PRO V2 55 EU = 49,8 kW - 5,1 kW;

VICTRIX PRO V2 60 EU = 58,5 kW - 7,5 kW;

VICTRIX PRO V2 68 EU = 63,4 kW - 7,5 kW;

VICTRIX PRO V2 80 EU = 73,2 kW - 7,5 kW;

and seasonal efficiency η_s 94%. They can reach η_s 98%, if coupled with Modulating remote control code 3.020358 and external probe.

The generators are type-approved for installation both in heating control unit and outside the building (with specific protection for open-air installation), can be used in the following configurations:

Standard sealed chamber and fan assisted (appliance type C₁₃ / C₃₃) - Using the vertical or horizontal concentric and split kits.

Open chamber and fan assisted (appliance type B_{23p} / B₃₃ / B_{53p}) - Specific optional intake stub pipe kit required.

The module consists of:

- total pre-mixing combustion system with steel multigas cylindrical burner, complete with ignition electrodes and ionisation control;
- pneumatic gas valve with double shutter;
- primary gas/water heat exchanger with casing in composite material with air vent valve and internal stainless steel coil, consisting of 5 elements (4+1 flue side - VICTRIX PRO V2 35 EU), of 7 elements (5+2 flue side - VICTRIX PRO V2 55 EU), of 9 elements (7+2 flue side - VICTRIX PRO V2 60 - 68 - 80 EU);
- combustion chamber in stainless steel internally insulated using ceramic panels;
- fan for flue evacuation with electronically variable speed;
- circuit for disposal of condensate including trap and flexible drain hose;
- hydraulic unit composed of a flow manifold, primary circuit pressure transducer, modulating circulation pump and low power consumption;
- 4 bar system safety valve and standard draining funnel;
- water overheating safety thermostat, heat exchanger safety thermofuse and heat exchanger safety thermostat (manual reset);
- flue control probe
- control panel supplied with P.C.B. with microprocessor with continuous flame modulation on heating with P.I.D. control, modulation range 1-10;
- system flow regulation probe;
- system return regulation probe;
- heating flow temperature with factory setting between 20 and 85°C;
- ignition delay device in central heating phase, antifreeze protection, pump anti-blocking function, chimney sweep function;
- control panel composed of main switch, C.H. system pressure

gauge, multifunction back-lit display and 12-key push button panel with protective sliding door;

- key setting of all functions, including antilegionella function if coupled with remote DHW storage tank with probe;
- self-diagnosis system with digital display of the temperature, functioning status and error codes;
- IPX5D electrical insulation level, with possibility of installation outside with additional cover (open-air);
- antifreeze protection to -5 °C as per standard (-15 °C with relevant kit optional);
- set-up for the connection of the cascade and zone regulator kit and of the external probe;
- set-up for connection to an external 3-way valve with 230 Vac power supply, for coupling to a separate storage tank unit for the production of DHW;
- set-up for functioning in set configuration (up to 5 boilers with a unique INAIL safety devices kit);
- set-up for the installation of the INAIL-approved safety stub pipes, both in single and set configuration (up to 5 boilers);
- possibility of installation with the supporting frame kit in "free standing" mode, which can be used to install one or more VICTRIX PRO V2 EU units. The frame is also suitable for outdoor open-air installation;
- possibility of installation of the generator within a cabinet suitable for outdoor installation;
- possibility of connecting (in combination with a cascade and zone regulator) to a remote management system for remote management of the system (optional);
- it can be combined with the system by 80Ø mm flexible ducting (single installation).

Supplied with sample points for combustion analysis, bottom protective metal-sheet plate and gas interception cock.

Category II appliance_{2H3P} operates with natural gas and L.P.G. CE Marking.

It is available in the following models:

- | | |
|------------------------|----------------|
| • VICTRIX PRO V2 35 EU | code: 3.034431 |
| • VICTRIX PRO V2 55 EU | code: 3.033857 |
| • VICTRIX PRO V2 60 EU | code: 3.033858 |
| • VICTRIX PRO V2 68 EU | code: 3.033859 |
| • VICTRIX PRO V2 80 EU | code: 3.033860 |



NOTA BENE: for correct installation of the boiler the Immergas "Green Range" air intake/fumes exhaust kit must be used, dedicated for the VICTRIX PRO V2 EU boiler, whether in single or cascade (set) configuration.

VICTRIX PRO V2 100 - 120 - 150 EU

2.1

VICTRIX PRO V2 100 - 120 - 150 EU SPECIFICATIONS

Wall-hung, sealed-chamber and fan-assisted pre-mixed condensing modules, high efficiency with forced circulation, with variable useful power outputs:

VICTRIX PRO V2 100 EU = 90,9 kW - 9,8 kW;

VICTRIX PRO V2 120 EU = 112,3 kW - 11,3 kW;

VICTRIX PRO V2 150 EU = 138,3 kW - 28,3 kW;

and seasonal efficiency η_s 94% (with the exclusion of VICTRIX PRO V2 150 EU). They can reach η_s 98%, if coupled with Modulating remote control code 3.020358.

The generators are type-approved for installation both in heating control unit and outside the building (with specific protection for open-air installation), can be used in the following configurations:

Standard sealed chamber and fan assisted (appliance type C₁₃/C₃₃) - Using the vertical or horizontal concentric and split kits.

Open chamber and fan assisted (appliance type B_{23p}/B₃₃/B_{53p}) - Specific optional intake stub pipe kit required.

The module consists of:

- total pre-mixing combustion system with steel multigas cylindrical burner, complete with ignition electrodes and ionisation control;
- pneumatic gas valve with double shutter;
- primary gas/water heat exchanger with casing in stainless steel with air vent valve and internal stainless steel coil, consisting of 12 elements (8+4 flue side - VICTRIX PRO V2 100 EU), of 15 elements (10+5 flue side - VICTRIX PRO V2 120 EU), of 18 elements (12+6 flue side - VICTRIX PRO V2 150 EU);
- combustion chamber in stainless steel internally insulated using ceramic panels;
- fan for flue evacuation with electronically variable speed;
- circuit for disposal of condensate including trap and flexible drain hose;
- hydraulic unit composed of a flow manifold, primary circuit pressure transducer, modulating circulation pump and low power consumption;
- 5,4 bar system safety valve and standard draining funnel;
- water overheating safety thermostat, heat exchanger safety thermofuse and heat exchanger safety thermostat (manual reset);
- flue control probe
- control panel supplied with P.C.B. with microprocessor with continuous flame modulation on heating with P.I.D. control, modulation range 1-10 (with the exclusion of mod. 150);
- system flow regulation probe;
- system return regulation probe;
- heating flow temperature with factory setting between 20 and 85°C;
- ignition delay device in central heating phase, antifreeze protection, pump anti-blocking function, chimney sweep function;
- control panel composed of main switch, C.H. system pressure gauge, multifunction back-lit display and 12-key push button panel with protective sliding door;

- key setting of all functions, including antilegionella function if coupled with remote DHW storage tank with probe;
- self-diagnosis system with digital display of the temperature, functioning status and error codes;
- IPX5D electrical insulation level, with possibility of installation outside with additional cover (open-air);
- antifreeze protection to -5 °C as per standard (-15 °C with relevant kit optional);
- set-up for the connection of the cascade and zone regulator kit and of the external probe;
- set-up for connection to an external 3-way valve with 230 Vac power supply, for coupling to a separate storage tank unit for the production of DHW;
- set-up for functioning in set configuration (up to 5 boilers with a unique INAIL safety devices kit);
- set-up for the installation of the INAIL-approved safety stub pipes, both in single and set configuration (up to 5 boilers);
- possibility of installation with the supporting frame kit in "free standing" mode, which can be used to install one or more VICTRIX PRO V2 EU units. The frame is also suitable for outdoor open-air installation;
- possibility of installation of the generator within a cabinet suitable for outdoor installation;
- possibility of connecting (in combination with a cascade and zone regulator) to a remote management system for remote management of the system (optional);

Supplied with sample points for combustion analysis, bottom protective metal-sheet plate and gas interception cock.

Category II appliance_{2H3P} operates with natural gas and L.P.G. CE Marking.

It is available in the following models:

- **VICTRIX PRO V2 100 EU** code: **3.033861**
- **VICTRIX PRO V2 120 EU** code: **3.033862**
- **VICTRIX PRO V2 150 EU** code: **3.033863**



NOTA BENE: for correct installation of the boiler the Immergas "Green Range" air intake/fumes exhaust kit must be used, dedicated for the VICTRIX PRO V2 EU boiler, whether in single or cascade (set) configuration.

2.2

VICTRIX PRO V2 180 EU SPECIFICATIONS

Wall-hung, sealed-chamber and fan-assisted pre-mixed condensing module, high efficiency with forced circulation, with variable useful power outputs:

VICTRIX PRO V2 180 EU = 165,9 kW - 30,4 kW.

The generator is type-approved for installation both in heating control unit and outside the building (with specific protection for open-air installation), can be used in the following configurations:

Standard sealed chamber and fan assisted (appliance type C₁₃ /C₃₃) - Using split kits.

Open chamber and fan assisted (appliance type B_{23p} /B₃₃)) - Specific optional intake stub pipe kit required.

The module consists of:

- total pre-mixing combustion system with steel multigas cylindrical burner, complete with ignition electrodes and ionisation control;
- pneumatic gas valve with double shutter;
- primary gas/water heat exchanger with casing in Stainless steel with air vent valve and internal stainless steel coil, composed of 23 elements (15+8 on flue side - VICTRIX PRO V2 180 EU);
- combustion chamber in stainless steel internally insulated using ceramic panels;
- fan for flue evacuation with electronically variable speed;
- circuit for disposal of condensate including trap and flexible drain hose;
- hydraulic unit composed of a flow manifold, primary circuit pressure transducer, modulating circulation pump and low power consumption;
- 5,4 bar system safety valve and standard draining funnel;
- water overheating safety thermostat, heat exchanger safety thermofuse and heat exchanger safety thermostat (manual reset);
- flue control probe
- control panel supplied with P.C.B. with microprocessor with continuous flame modulation on heating with P.I.D. control, modulation range 1-5;
- system flow regulation probe;
- system return regulation probe;
- heating flow temperature with factory setting between 20 and 85°C;
- ignition delay device in central heating phase, antifreeze protection, pump anti-blocking function, chimney sweep function;
- control panel composed of main switch, C.H. system pressure gauge, multifunction back-lit display and 12-key push button panel with protective sliding door;
- setting and adjustment of operation parameters of the boiler using keys;
- key setting and adjustment of boiler operation parameters, including antilegionella function if coupled with remote DHW storage tank with probe;
- IPX5D electrical insulation level, with possibility of installation outside with additional cover (open-air);
- antifreeze protection to -5 °C as per standard (-15 °C with

relevant kit optional);

- set-up for the connection of the cascade and zone regulator kit and of the external probe;
- set-up for connection to an external 3-way valve with 230 Vac power supply, for coupling to a separate storage tank unit for the production of DHW;
- set-up for functioning in set configuration (up to 5 boilers with a unique INAIL safety devices kit);
- set-up for the installation of the INAIL-approved safety stub pipes, both in single and set configuration (up to 5 boilers);
- possibility of installation with the supporting frame kit in "free standing" mode, which can be used to install one or more VICTRIX PRO V2 EU units. The frame is also suitable for outdoor open-air installation;
- possibility of connecting (in combination with a cascade and zone regulator) to a remote management system for remote management of the system (optional).

Supplied with sample points for combustion analysis, bottom protective metal-sheet plate and gas interception cock and reinforcement bracket for wall fixing.

Category II appliance_{2H3P} operates with natural gas and L.P.G. CE Marking.

It is available in the following models:

- **VICTRIX PRO V2 180 EU** **cod. 3.033864**



NOTA BENE: for correct installation of the boiler the Immergas "Green Range" air intake/fumes exhaust kit must be used, dedicated for the VICTRIX PRO V2 EU boiler, whether in single or cascade (set) configuration.

VICTRIX PRO V2 35 - 55 - 60 - 68 - 80 EU

3 VICTRIX PRO V2 35 - 55 - 60 - 68 - 80 EU MAIN DIMENSIONS

Model	Height mm	Width mm	Depth mm
VICTRIX PRO V2 35 - 55 - 60 - 68 - 80 EU	851 (985)	440	499

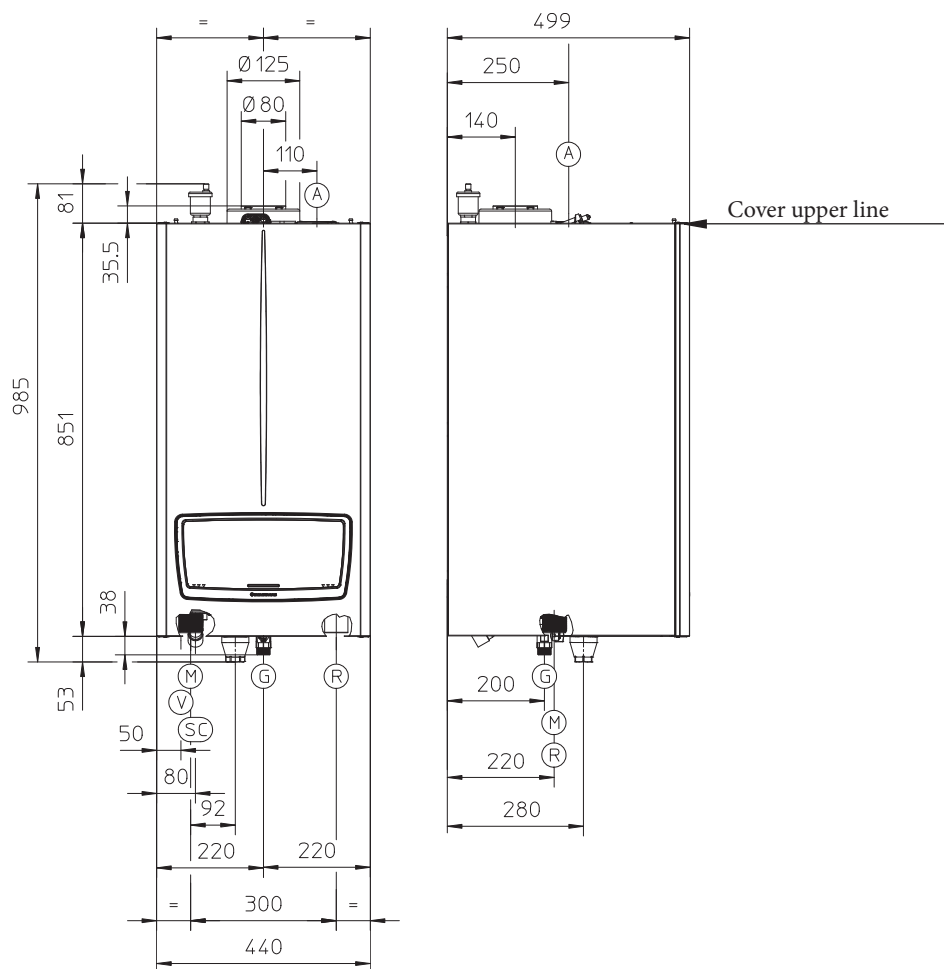

SC = Condensate drain Ø 25 mm

Model	System flow	System return	Gas Supply
VICTRIX PRO V2 35 EU	M 1" 1/2	R 1" 1/2	G 3/4"
VICTRIX PRO V2 55 EU	1" 1/2	1" 1/2	3/4"
VICTRIX PRO V2 60 EU	1" 1/2	1" 1/2	3/4"
VICTRIX PRO V2 68 EU	1" 1/2	1" 1/2	3/4"
VICTRIX PRO V2 80 EU	1" 1/2	1" 1/2	3/4"

VICTRIX PRO V2 100 - 120 - 150 EU

3.1 VICTRIX PRO V2 100 - 120 EU MAIN DIMENSIONS

Model	Height mm	Width mm	Depth mm
VICTRIX PRO V2 100 - 120 EU	1098 (1232)	600	557

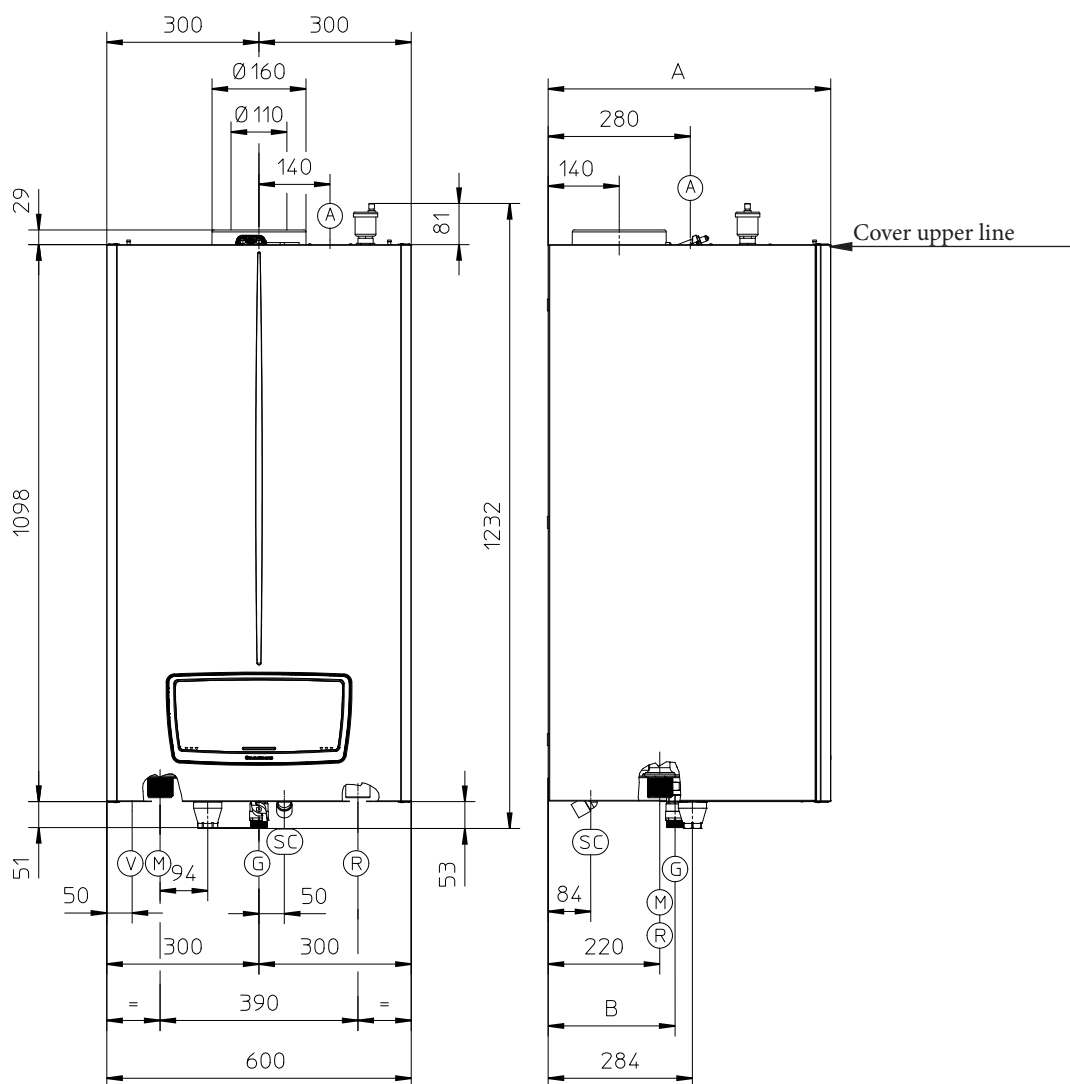

SC = Condensate drain \varnothing 25 mm

Model	System flow M	System return R	Gas Supply G
VICTRIX PRO V2 100 EU	1" 1/2	1" 1/2	1"
VICTRIX PRO V2 120 EU	1" 1/2	1" 1/2	1"

VICTRIX PRO V2 100 - 120 - 150 EU

3.2 VICTRIX PRO V2 150 EU MAIN DIMENSIONS

Model	Height mm	Width mm	Depth mm
VICTRIX PRO V2 150 EU	1098 (1232)	600	627

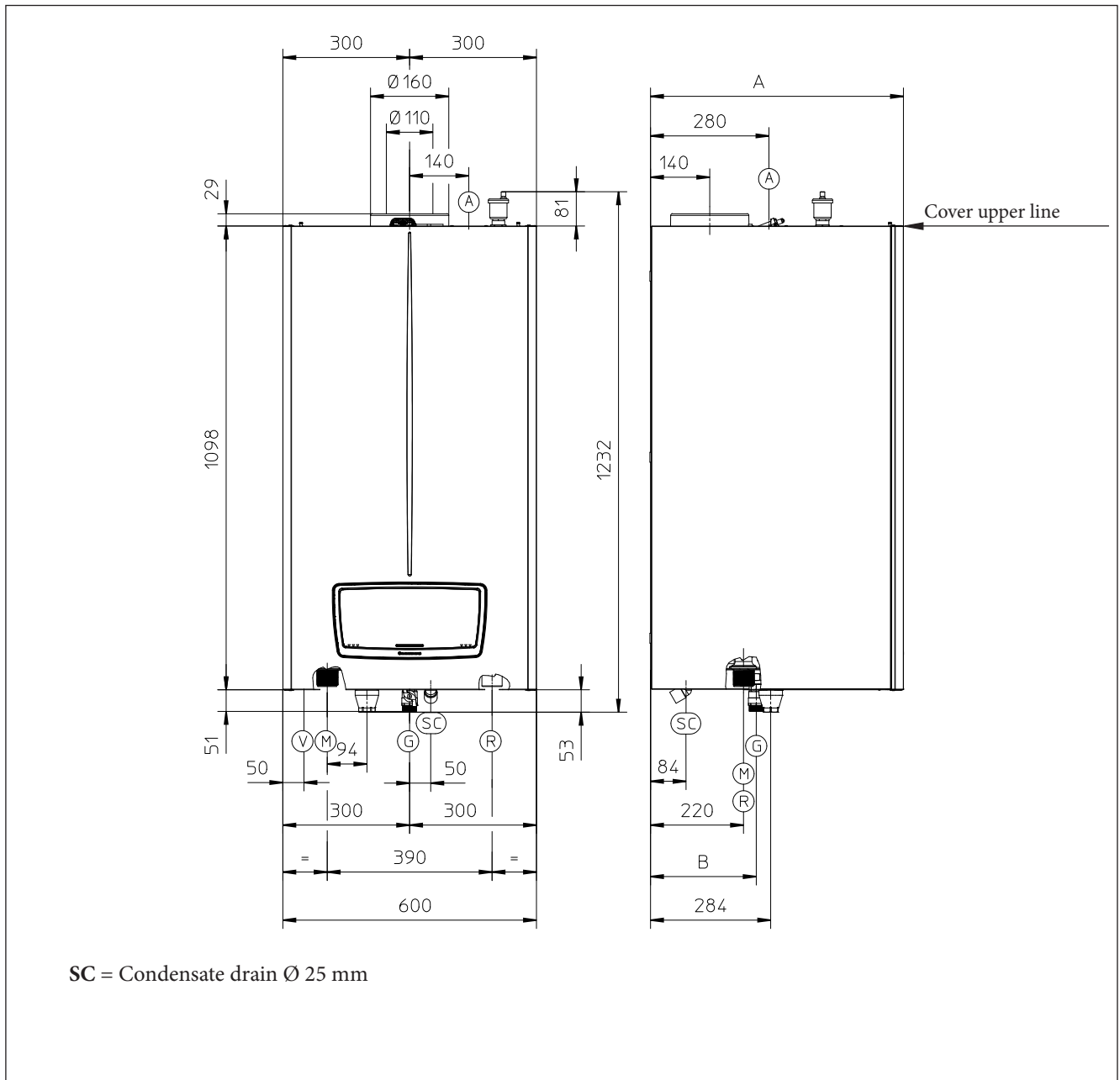

Model	System flow M	System return R	Gas Supply G
VICTRIX PRO V2 150 EU	1" 1/2	1" 1/2	1"

3.3

VICTRIX PRO V2 180 EU MAIN DIMENSIONS

Model	Height mm	Width mm	Depth mm
VICTRIX PRO V2 180 EU	1098 (1232)	600	882

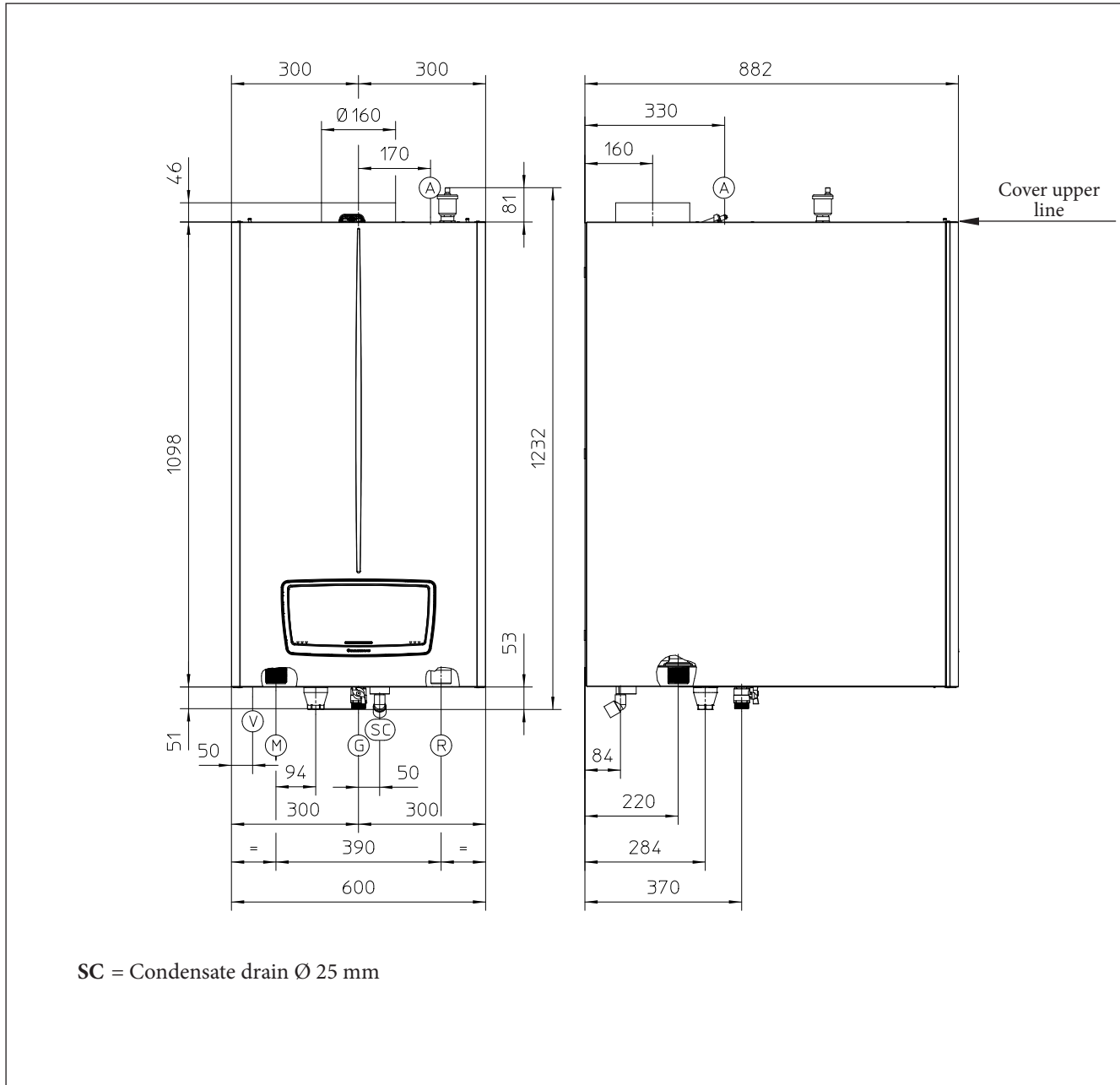

Model	System flow	System return	Gas Supply
VICTRIX PRO V2 180 EU	M 1" 1/2	R 1" 1/2	G 1"

VICTRIX PRO V2 35 - 55 - 60 - 68 - 80 EU

4

VICTRIX PRO V2 35 - 55 - 60 - 68 - 80 EU COMPONENTS

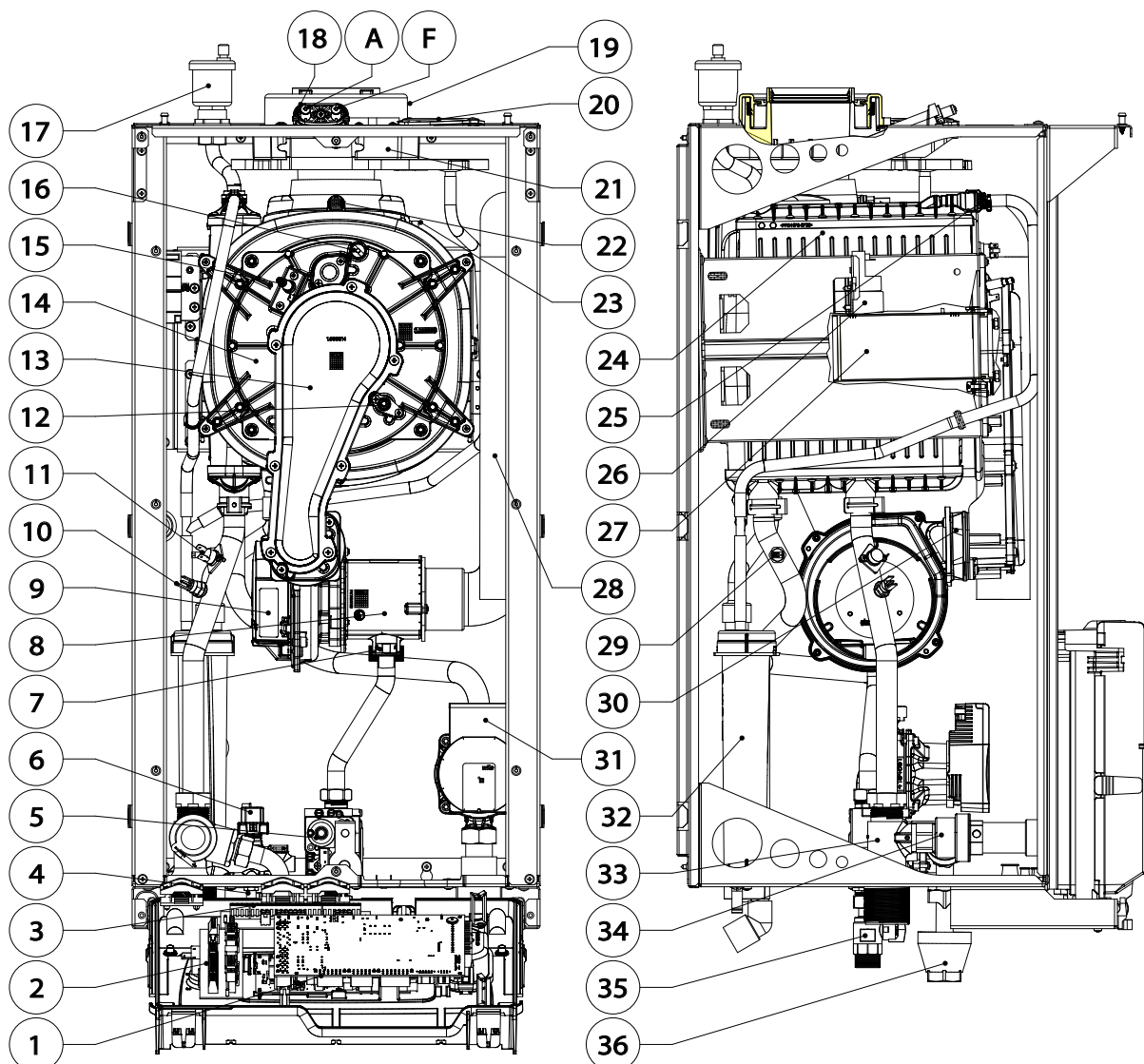

KEY:

- | | | | |
|----|--|----|--------------------------------------|
| 1 | - P.C.B. | 19 | - Concentric intake cap Ø 125 |
| 2 | - High power connection board | 20 | - Intake closing cap 80 Ø |
| 3 | - Low power connection board | 21 | - Flange with sample points |
| 4 | - Drain fitting | 22 | - Flue probe |
| 5 | - Gas valve | 23 | - Heat exchanger safety thermofuse |
| 6 | - Pressure transducer | 24 | - Condensation module |
| 7 | - Gas nozzle | 25 | - Condensation module air vent valve |
| 8 | - Venturi | 26 | - Igniter |
| 9 | - Fan | 27 | - Burner |
| 10 | - System flow adjustment NTC probe | 28 | - Air intake pipe |
| 11 | - Overheating safety thermostat | 29 | - System return adjustment NTC probe |
| 12 | - Detection electrode | 30 | - Fan adapter |
| 13 | - Gas manifold cover | 31 | - Pump |
| 14 | - Gas manifold | 32 | - Condensate siphon |
| 15 | - Ignition glow plug | 33 | - Flow manifold |
| 16 | - Klixon thermostat | 34 | - 4 bar safety valve |
| 17 | - Air vent valve | 35 | - Gas cock |
| 18 | - Sample points (air A) - (flue gases F) | 36 | - Draining funnel |

4.1 VICTRIX PRO V2 100 - 120 EU COMPONENTS

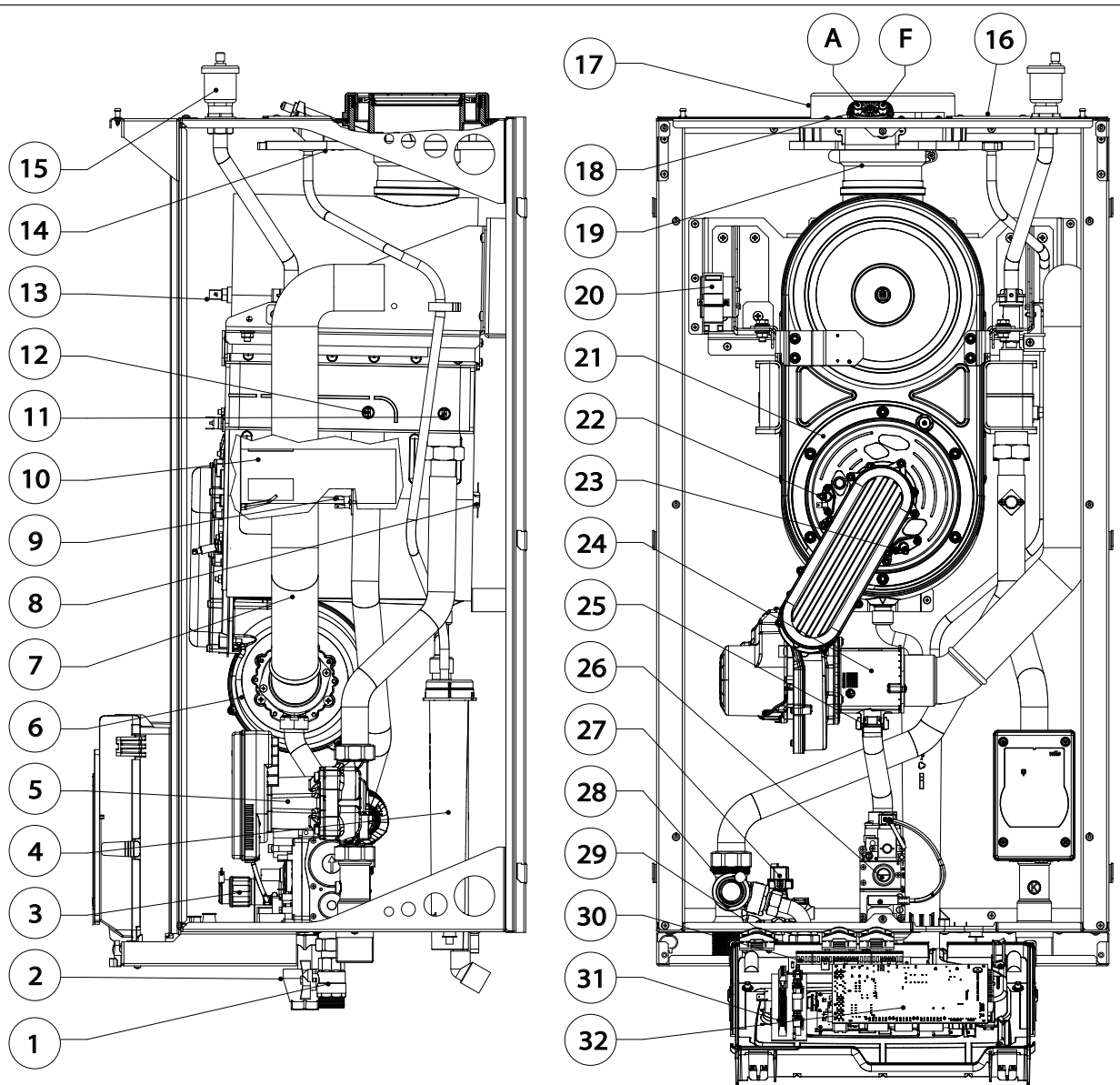

KEY:

- | | | | |
|----|--------------------------------------|----|--|
| 1 | - Gas cock | 17 | - Concentric intake cap Ø 160 |
| 2 | - Draining funnel | 18 | - Sample points (air A) - (flue gases F) |
| 3 | - 5.4 bar safety valve | 19 | - Flange connection module-flue hood |
| 4 | - Condensate siphon | 20 | - Igniter |
| 5 | - Pump | 21 | - Combustion group |
| 6 | - Fan | 22 | - Detection electrode |
| 7 | - Air intake pipe | 23 | - Ignition glow plug |
| 8 | - Heat exchanger safety thermofuse | 24 | - Venturi |
| 9 | - Overheating safety thermostat | 25 | - Gas nozzle |
| 10 | - Burner | 26 | - Gas valve |
| 11 | - System return adjustment NTC probe | 27 | - Pressure transducer |
| 12 | - System flow adjustment NTC probe | 28 | - Flow hydraulic unit |
| 13 | - Flue probe with thermofuse | 29 | - Drain fitting |
| 14 | - Flange with sample points | 30 | - Low power connection board |
| 15 | - Automatic air vent valve | 31 | - High power connection board |
| 16 | - Intake closing cap 100 Ø | 32 | - P.C.B. |

VICTRIX PRO V2 100 - 120 - 150 EU

4.2

VICTRIX V2 PRO 150 EU COMPONENTS

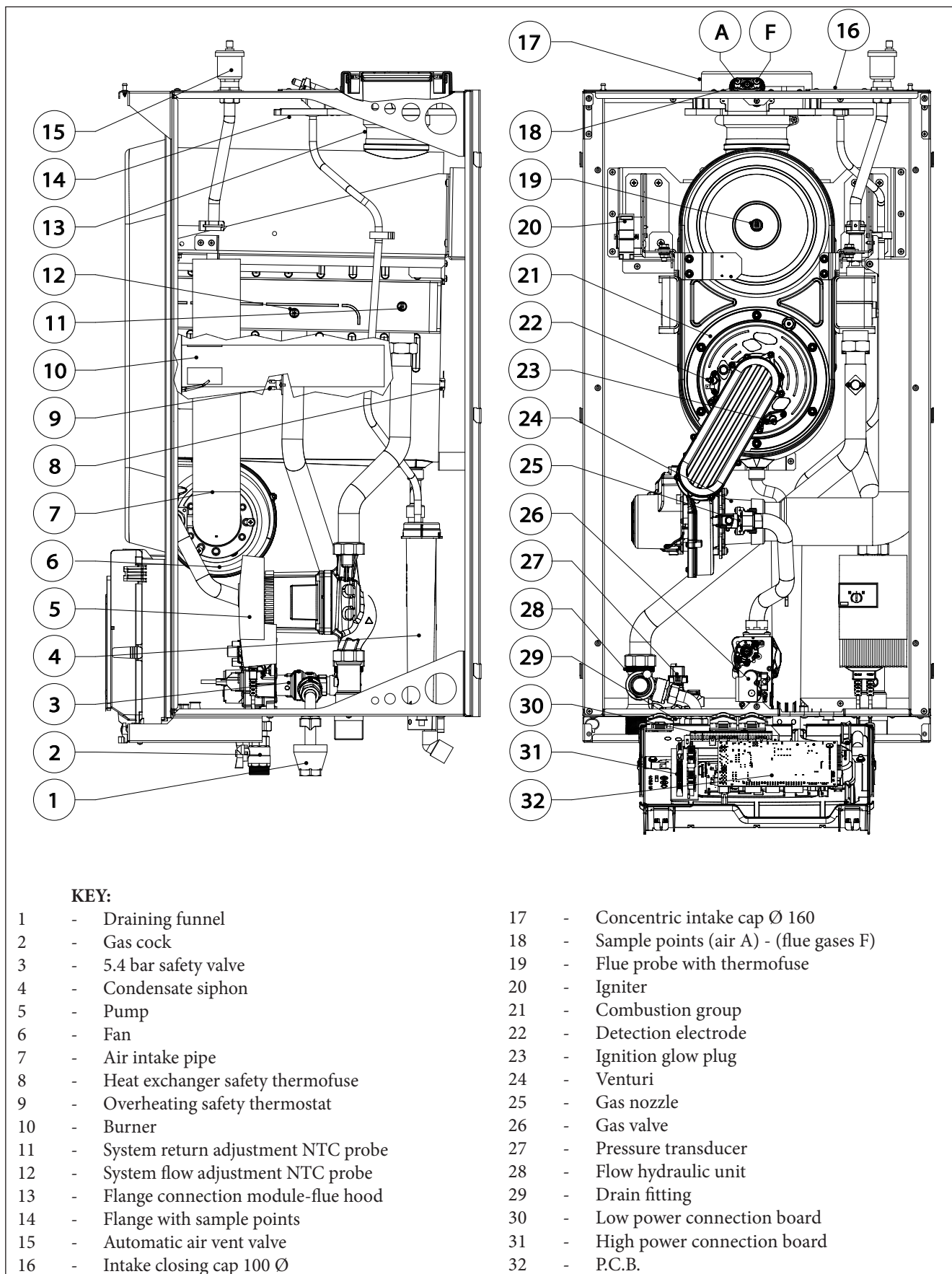

4.3

VICTRIX PRO V2 180 EU COMPONENTS

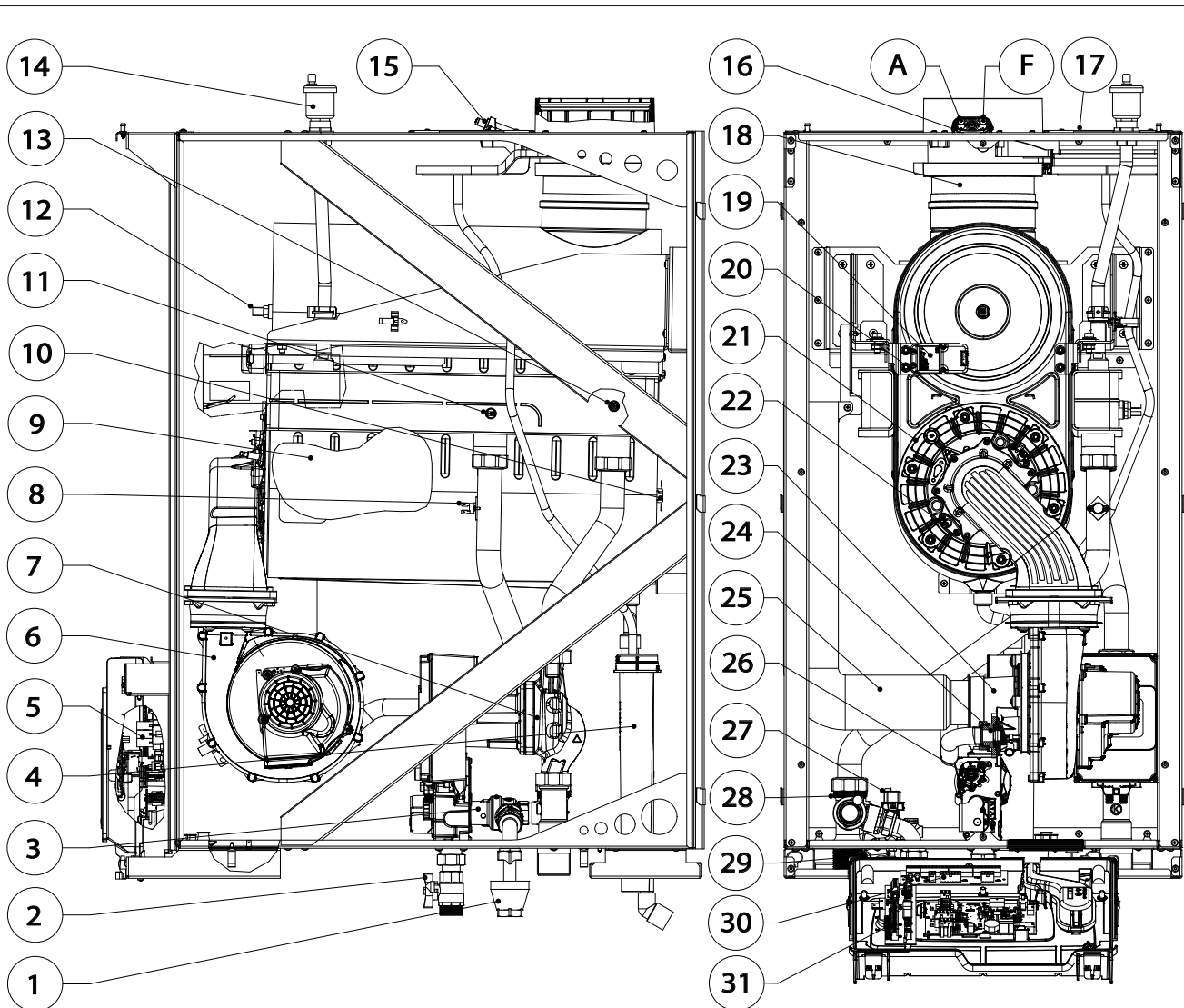

KEY:

- | | | | |
|----|--|----|--------------------------------------|
| 1 | - Draining funnel | 17 | - Intake closing cap 160 Ø |
| 2 | - Gas cock | 18 | - Flange connection module-flue hood |
| 3 | - 5.4 bar safety valve | 19 | - Igniter |
| 4 | - Condensate siphon | 20 | - Ignition glow plug |
| 5 | - P.C.B. | 21 | - Combustion group |
| 6 | - Fan | 22 | - Detection electrode |
| 7 | - Pump | 23 | - Venturi |
| 8 | - Overheating safety thermostat | 24 | - Gas nozzle |
| 9 | - Burner | 25 | - Air intake pipe |
| 10 | - Heat exchanger safety thermofuse | 26 | - Gas valve |
| 11 | - System flow adjustment NTC probe | 27 | - Pressure transducer |
| 12 | - Flue probe with thermofuse | 28 | - Flow hydraulic unit |
| 13 | - System return adjustment NTC probe | 29 | - Drain fitting |
| 14 | - Automatic air vent valve | 30 | - Low power connection board |
| 15 | - Flange with sample points | 31 | - High power connection board |
| 16 | - Sample points (air A) - (flue gases F) | | |

VICTRIX PRO V2 35 - 55 - 60 - 68 - 80 EU

5

VICTRIX PRO V2 35 - 55 - 60 - 68 - 80 EU HYDRAULIC DIAGRAM

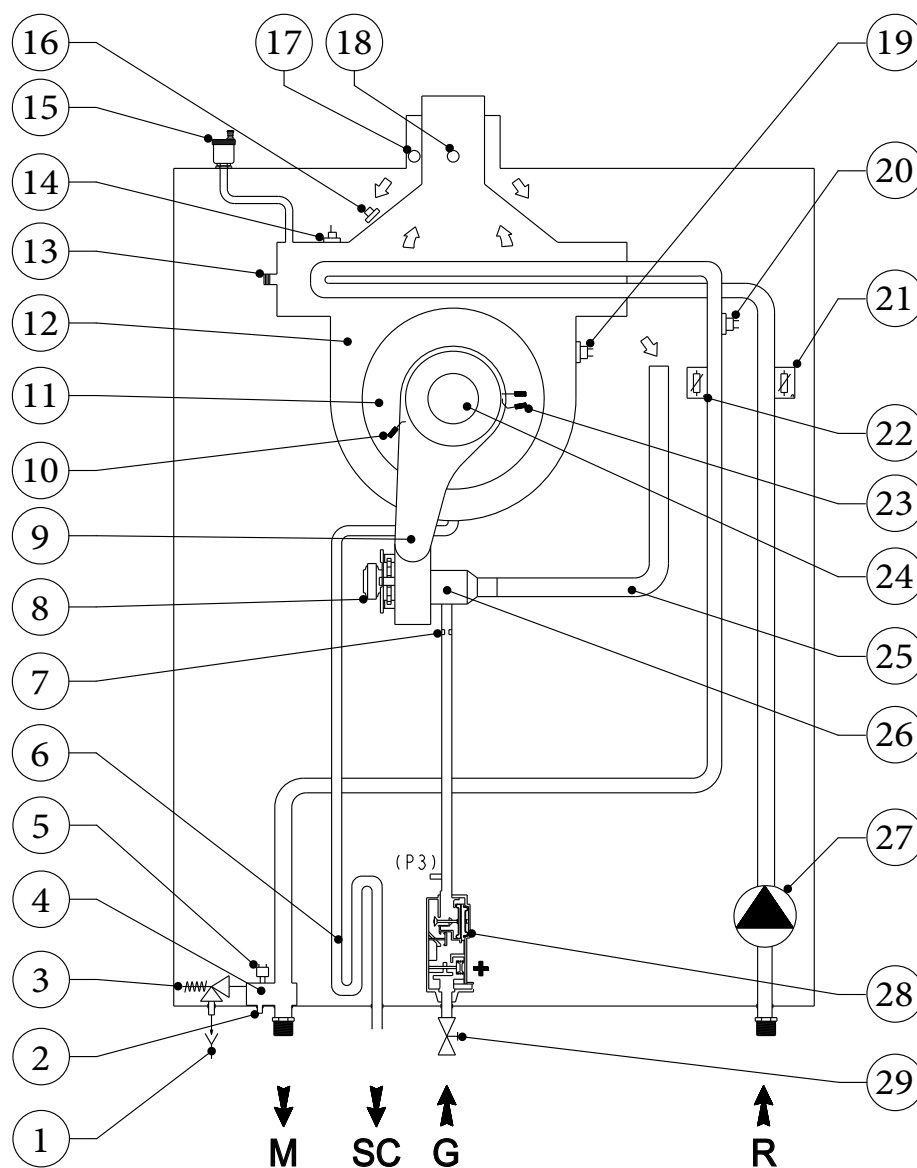

KEY:

- | | |
|--|---------------------------------------|
| 1 - Draining funnel on view | 18 - Flue sample point |
| 2 - Boiler draining cock | 19 - Safety thermostat (manual reset) |
| 3 - 4 bar safety valve | 20 - Overheating safety thermostat |
| 4 - Flow manifold | 21 - System return regulation probe |
| 5 - Pressure transducer | 22 - System flow regulation probe |
| 6 - Condensate trap siphon | 23 - Detection electrode |
| 7 - Gas nozzle | 24 - Burner |
| 8 - Air fan | 25 - Air intake pipe |
| 9 - Manifold cover | 26 - Venturi |
| 10 - Ignition electrode | 27 - Pump |
| 11 - Condensation module cover | 28 - Gas valve |
| 12 - Condensation module | 29 - Gas cock |
| 13 - Condensation module manual vent valve | |
| 14 - Flue probe | M - System flow |
| 15 - Condensation module air vent valve | SC - Condensate drain |
| 16 - Thermofuse | G - Gas supply |
| 17 - Air sample point | R - System return |

VICTRIX PRO V2 100 - 120 - 150 EU

5.1 VICTRIX PRO V2 100 - 120 - 150 EU HYDRAULIC DIAGRAM

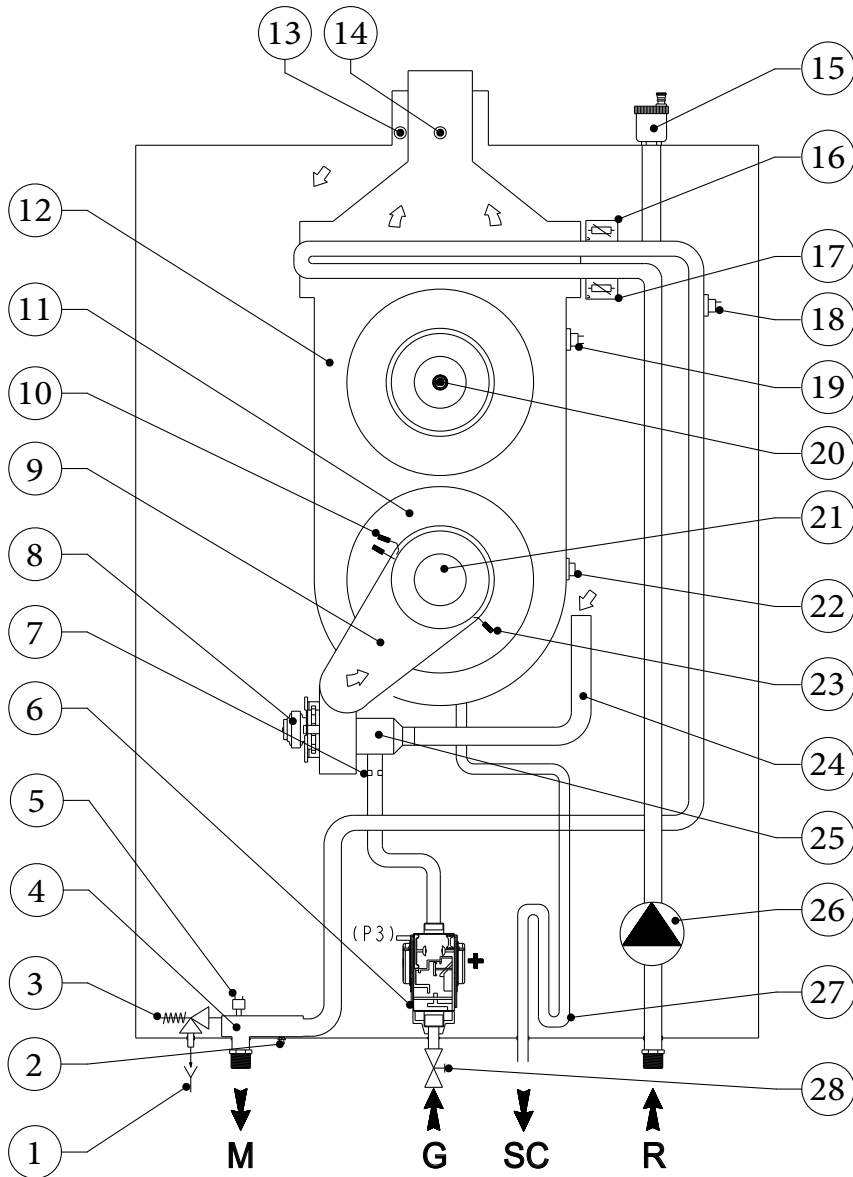

KEY:

- | | |
|---|---------------------------------------|
| 1 - Draining funnel on view | 18 - Overheating safety thermostat |
| 2 - Boiler draining cock | 19 - Safety thermostat (manual reset) |
| 3 - 5.4 bar safety valve | 20 - Flue probe with thermofuse |
| 4 - Flow manifold | 21 - Burner |
| 5 - Pressure transducer | 22 - Heat exchanger safety thermofuse |
| 6 - Gas valve | 23 - Ignition electrode |
| 7 - Gas nozzle | 24 - Air intake pipe |
| 8 - Air fan | 25 - Venturi |
| 9 - Manifold cover | 26 - Pump |
| 10 - Ignition electrode | 27 - Condensate trap siphon |
| 11 - Condensation module cover | 28 - Gas cock |
| 12 - Condensation module | |
| 13 - Air sample point | M - System flow |
| 14 - Flue sample point | SC - Condensate drain |
| 15 - Condensation module air vent valve | G - Gas supply |
| 16 - System flow regulation probe | R - System return |
| 17 - System return regulation probe | |

VICTRIX PRO V2 180 EU

5.2

VICTRIX PRO V2 180 EU HYDRAULIC DIAGRAM

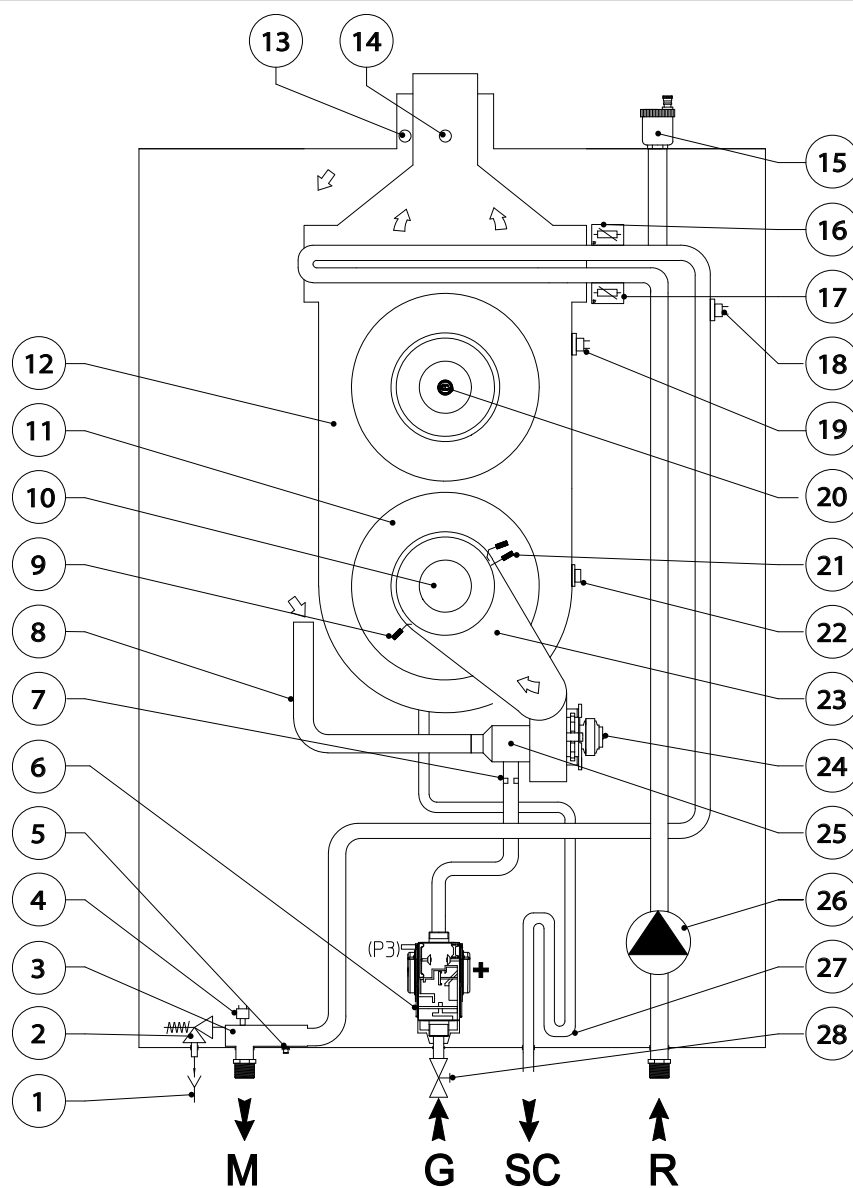

KEY:

- | | |
|---|---------------------------------------|
| 1 - Draining funnel on view | 18 - Overheating safety thermostat |
| 2 - 5.4 bar safety valve | 19 - Safety thermostat (manual reset) |
| 3 - Flow manifold | 20 - Flue probe with thermofuse |
| 4 - Pressure transducer | 21 - Ignition electrode |
| 5 - Device draining cock | 22 - Heat exchanger safety thermofuse |
| 6 - Gas valve | 23 - Manifold cover |
| 7 - Gas nozzle | 24 - Air fan |
| 8 - Air intake pipe | 25 - Venturi |
| 9 - Detection electrode | 26 - Pump |
| 10 - Burner | 27 - Condensate trap siphon |
| 11 - Condensation module cover | 28 - Gas cock |
| 12 - Condensation module | |
| 13 - Air sample point | M - System flow |
| 14 - Flue sample point | SC - Condensate drain |
| 15 - Condensation module air vent valve | G - Gas supply |
| 16 - System flow regulation probe | R - System return |
| 17 - System return regulation probe | |

VICTRIX PRO V2 35 - 55 - 60 - 68 - 80 EU

6 VICTRIX PRO V2 EU PUMP HEAD FLOW RATE GRAPH

The entire range of VICTRIX PRO V2 EU generators is supplied with a single-phase pump (230 V - 50 Hz) with variable speed control and low power consumption. When the heater is warming up, pump speed is defined according to the settings of the boiler parameters: maximum speed 100% and minimum speed 77 % (parameters preconfigured on VICTRIX PRO V2 35 - 55 - 60 - 68 - 80 EU); maximum speed

100% and minimum speed 50 % (parameters preconfigured on VICTRIX PRO V2 100 - 120 - 150 - 180 EU). Parameter settings can be adjusted based on actual needs. The pump always works at maximum speed during production of domestic hot water.

6.1 VICTRIX PRO V2 35 EU PUMP

GRUNDOFOS UPM 4L

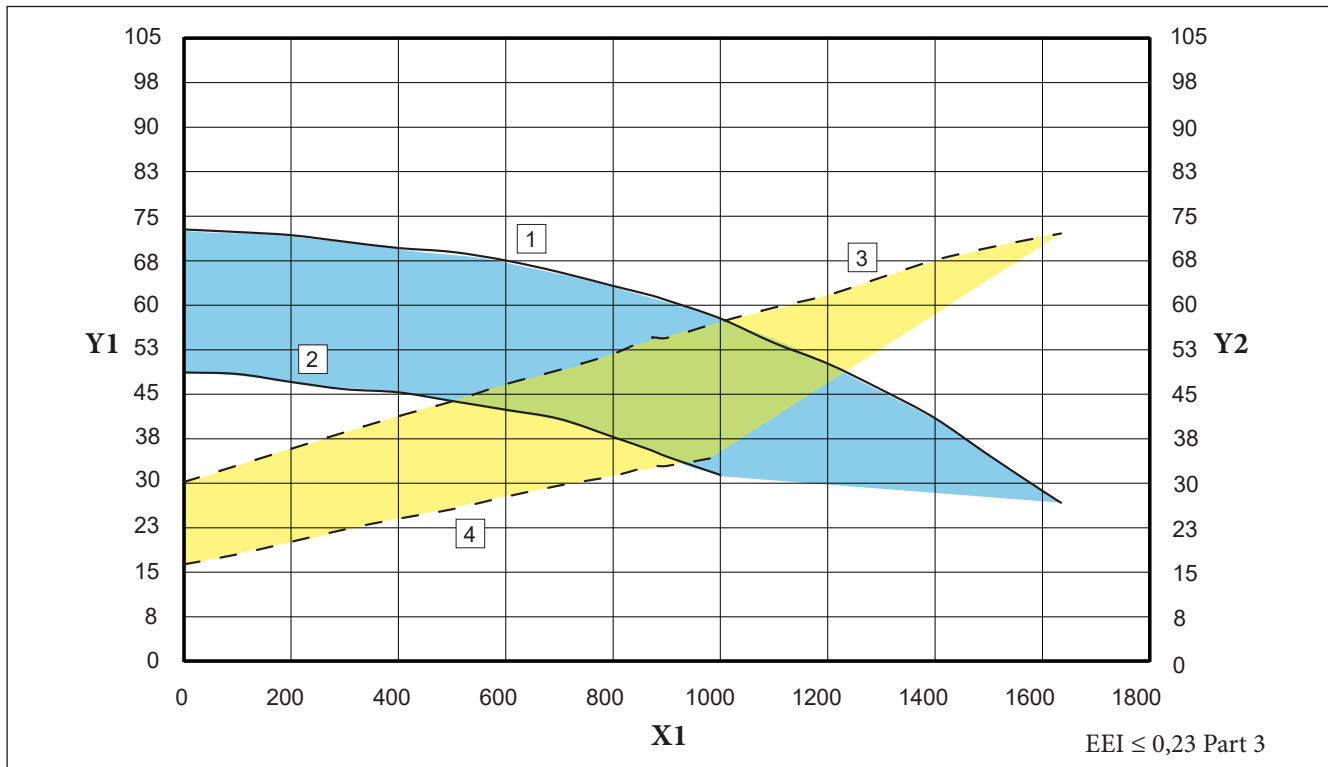

- 1 = Head available to the system at 100%
 - 2 = Head available to the system at 77%
 - 3 = Power absorbed by the pump at 100%
 - 4 = Power absorbed by the pump at 77%
- Area between 1 and 2 = Available system head
Area between 3 and 4 = Pump absorbed power
- X1 = Flow rate (l/h)
 - Y1 = Head (kPa)
 - Y2 = Power absorbed by pump (W)

VICTRIX PRO V2 35 - 55 - 60 - 68 - 80 EU

6.2

VICTRIX PRO V2 55 EU PUMP

GRUNDOFOS UPM 4L

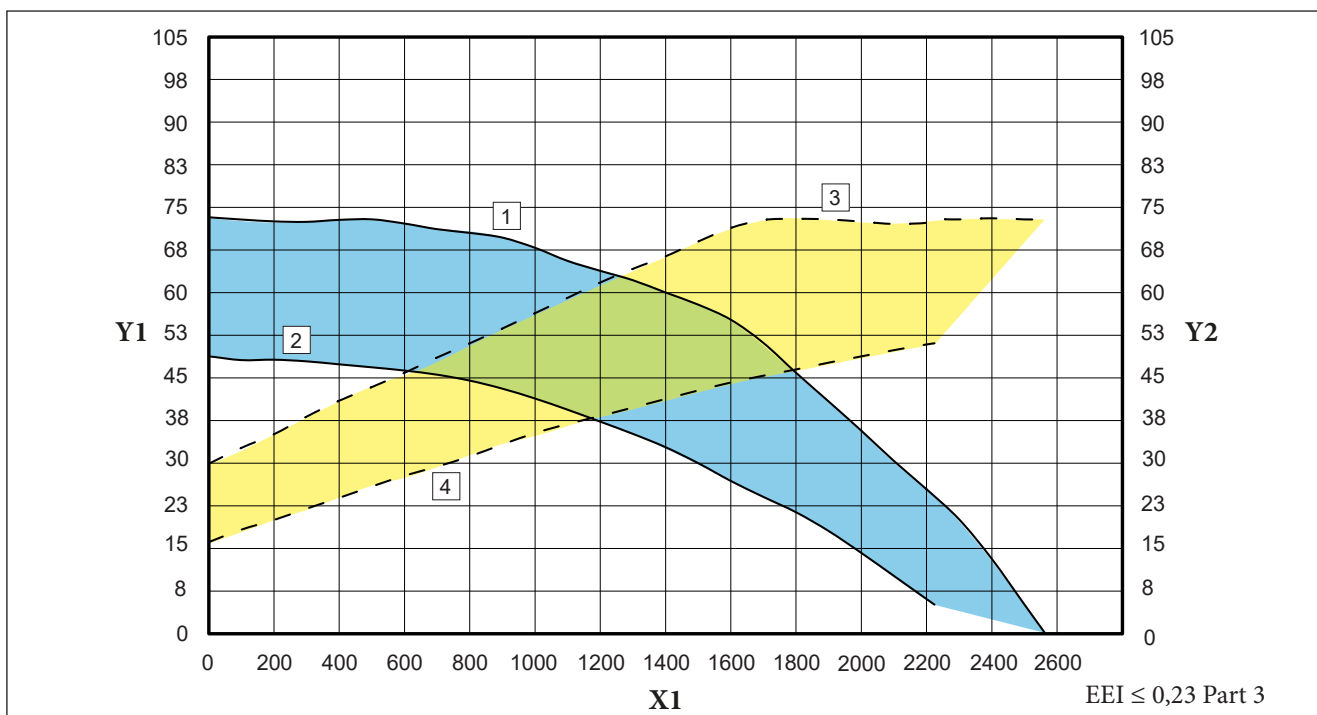

6.3

VICTRIX PRO V2 60 - 68 - 80 EU PUMP

GRUNDOFOS UPM XL

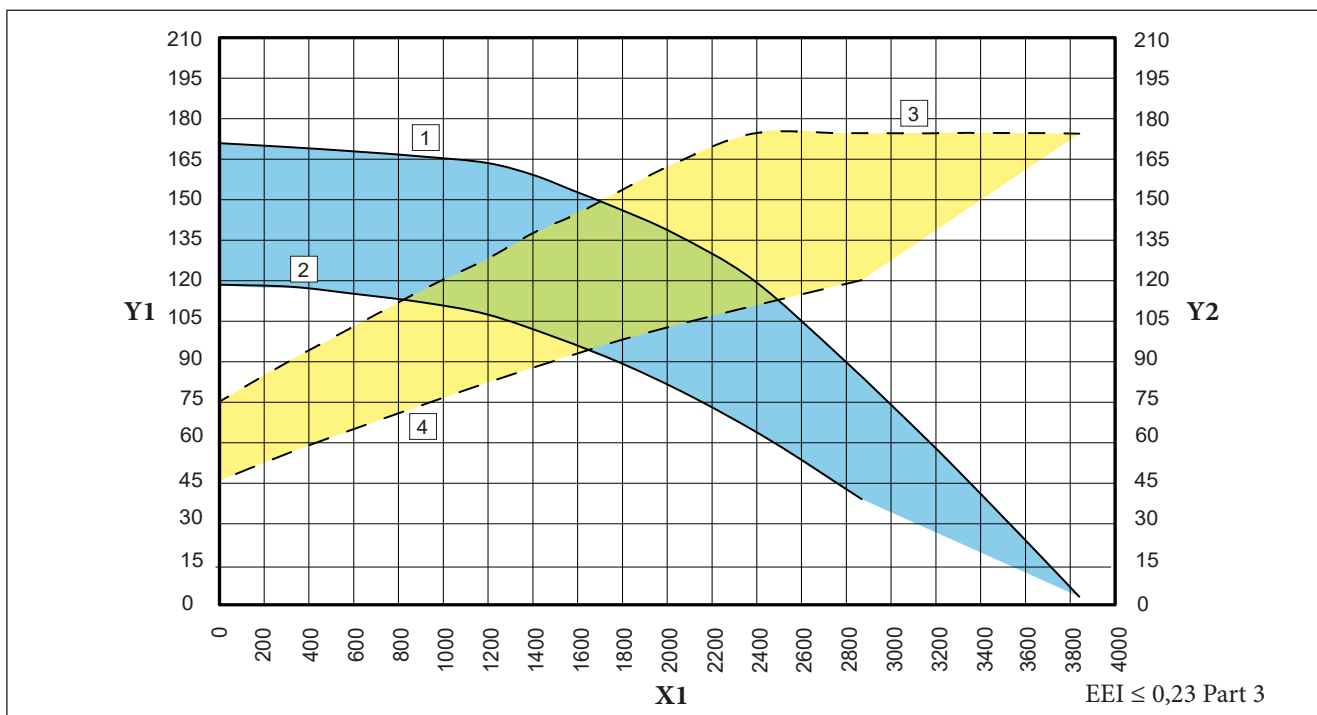

- 1 = Head available to the system at 100%
- 2 = Head available to the system at 77%
- 3 = Power absorbed by the pump at 100%
- 4 = Power absorbed by the pump at 77%

- X1 = Flow rate (l/h)
- Y1 = Head (kPa)
- Y2 = Power absorbed by pump (W)

VICTRIX PRO V2 100 - 120 - 150 EU

6.4 VICTRIX PRO V2 100 EU PUMP

GRUNDOFOS UPM XL

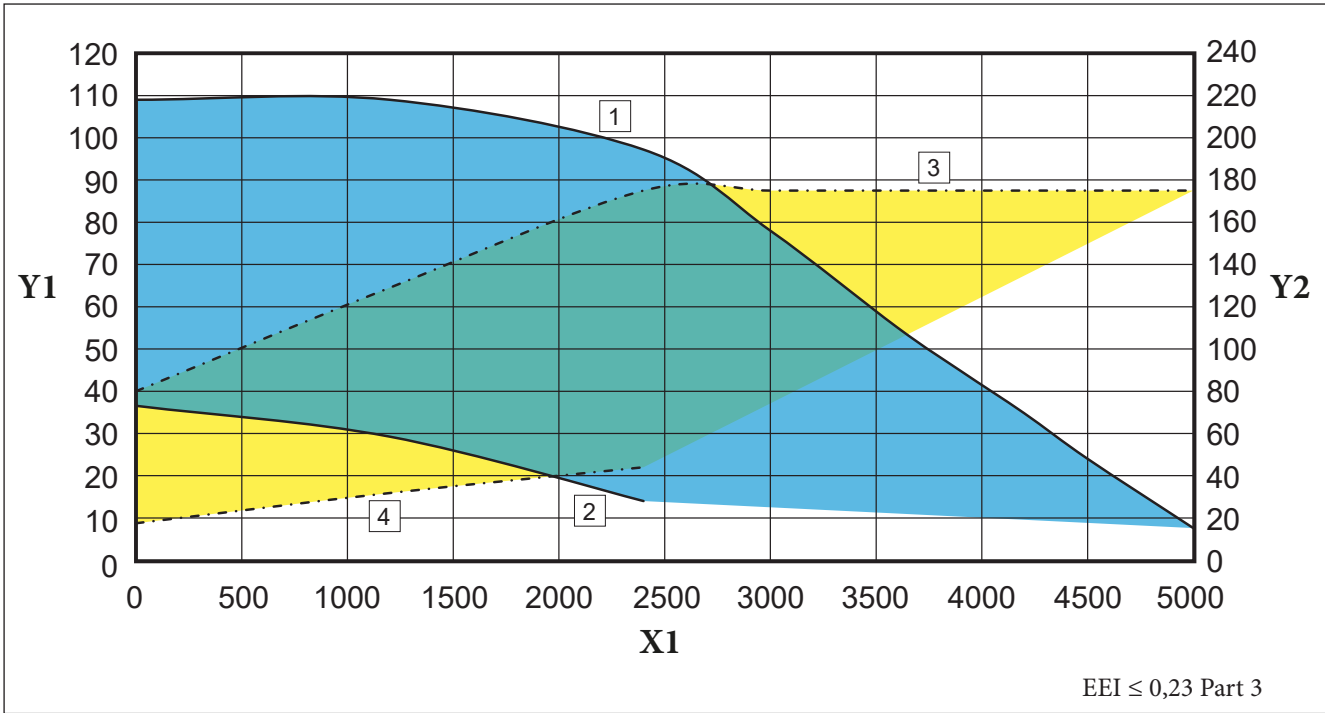

6.5 VICTRIX PRO V2 120 EU PUMP

GRUNDOFOS UPM XL

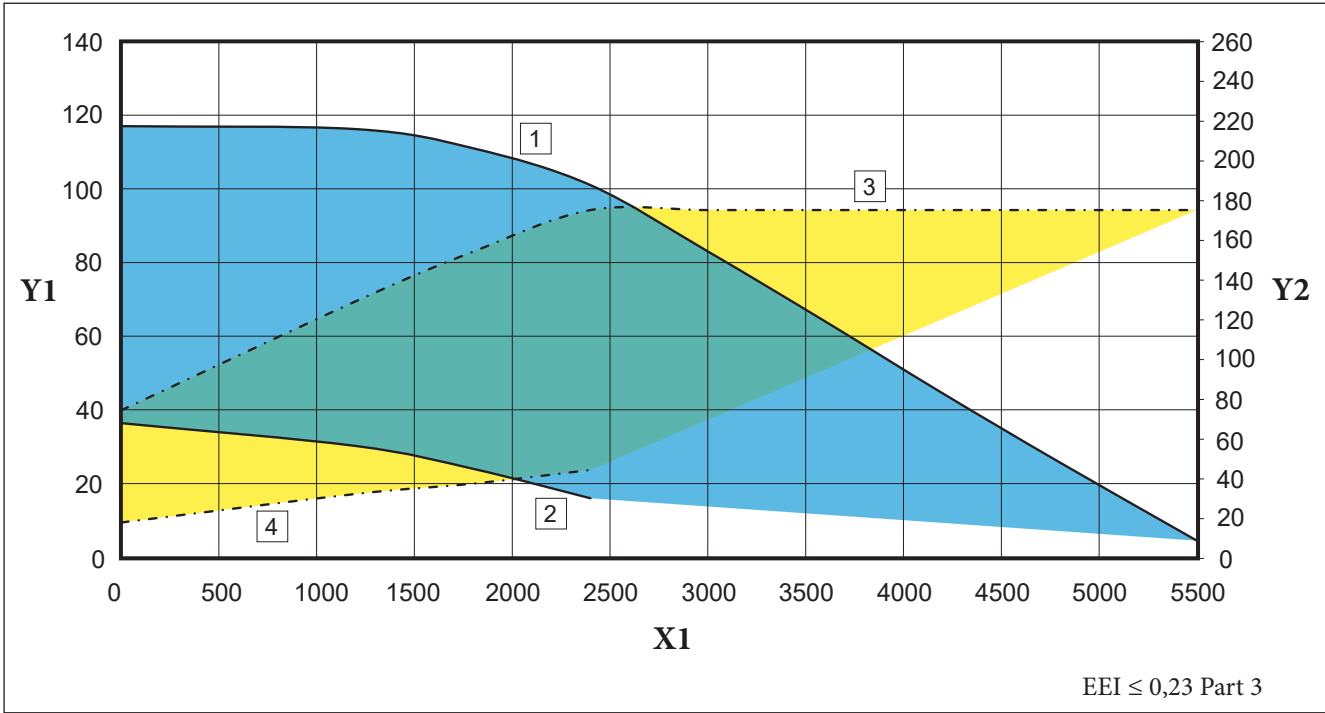

- | | | | | | |
|---|---|--------------------------------------|----|---|----------------------------|
| 1 | = | Head available to the system at 100% | X1 | = | Flow rate (l/h) |
| 2 | = | Head available to the system at 50% | Y1 | = | Head (kPa) |
| 3 | = | Power absorbed by the pump at 100% | Y2 | = | Power absorbed by pump (W) |
| 4 | = | Power absorbed by the pump at 50% | | | |

VICTRIX PRO V2 100 - 120 - 150 - 180 EU

6.6

VICTRIX PRO V2 150 EU PUMP

WILO STRATOS PARA C

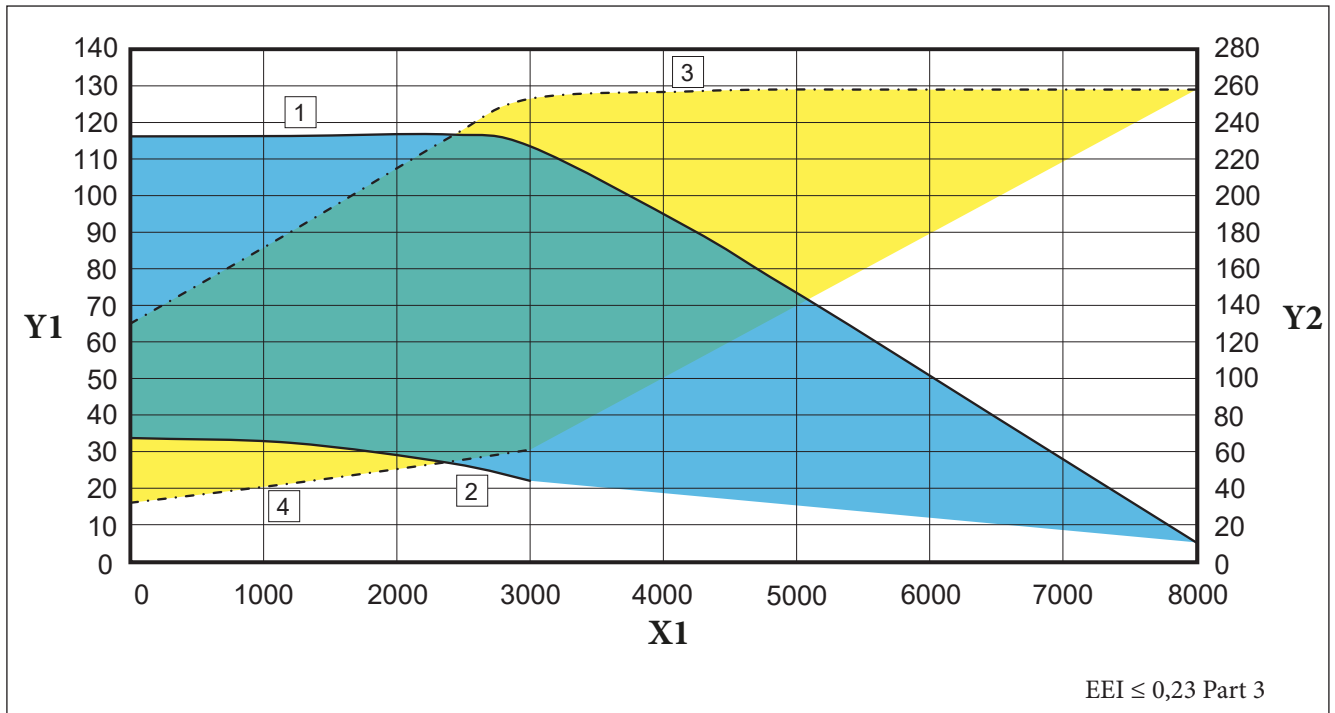

6.7

VICTRIX PRO V2 180 EU PUMP

WILO STRATOS PARA C

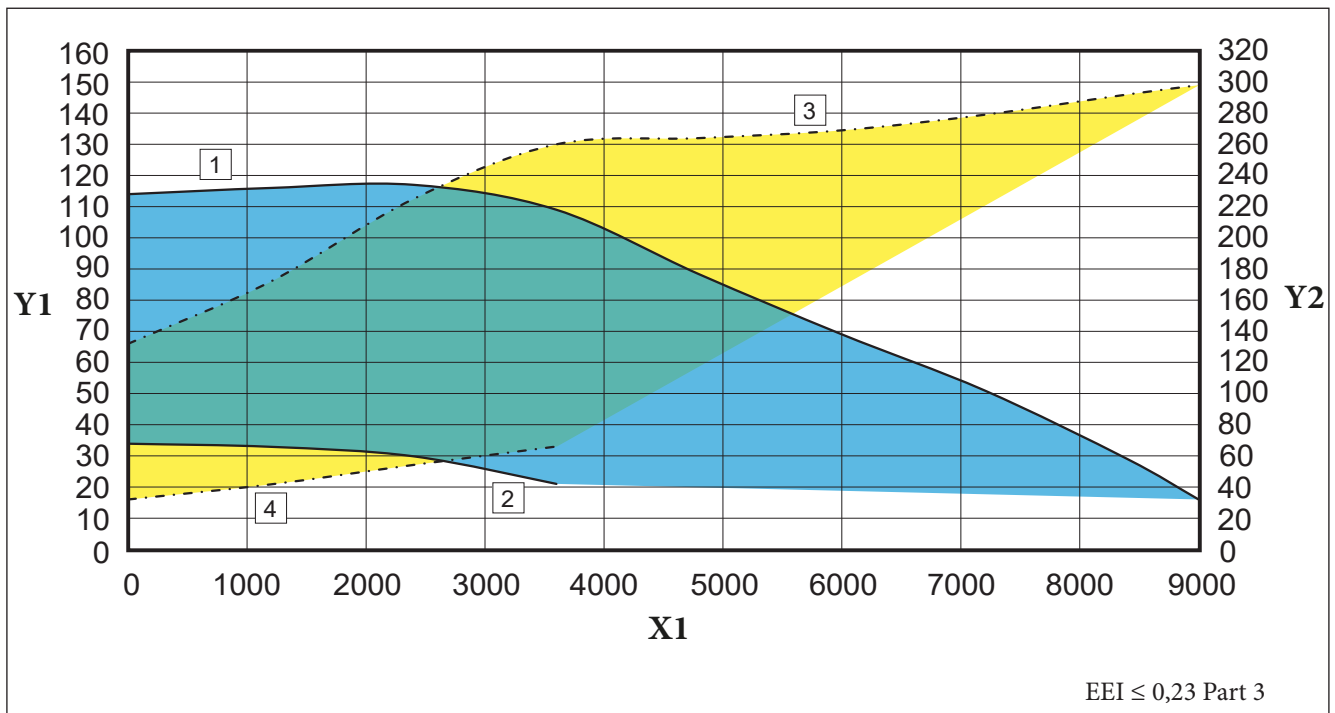

- 1 = Head available to the system at 100%
- 2 = Head available to the system at 50%
- 3 = Power absorbed by the pump at 100%
- 4 = Power absorbed by the pump at 50%

- X1 = Flow rate (l/h)
- Y1 = Head (kPa)
- Y2 = Power absorbed by pump (W)

Treating the feed water allows you to prevent problems and maintain the function and efficiency of the generator over time.

Immergas S.p.A. reminds you that all types of systems require all building categories to treat the system's water, whether they are "new buildings and renovated existing buildings" or "new installation and renovation of heating systems or boiler replacement".

Water treatment means first thoroughly cleaning the thermal system (washing) and then appropriately treating the water filling the system, in particular:

- by more than 25 French degrees, if the system does not produce domestic hot water,
- by more than 15 French degrees, if the system produces domestic hot water, through chemical conditioning treatment for outputs of < 100 kW – or softening for outputs between 100 and 350 kW.

The Italian standard UNI 8065:

- Assumes that, prior to treatment, the water intended to supply heating systems for civil use has the same characteristics as drinking water.
- Requires the design phase to include treatment or chemical conditioning systems to provide the water in the circuit with the following characteristics:
 - appearance clear;
 - pH greater than 7 (but less than 8 for systems with aluminium radiators);
 - iron content: less than 0,5 mg/kg;
 - copper content: less than 0,1 mg/kg.

As for hot water central heating systems, according to the standard:

- for all systems, it is necessary to provide chemical conditioning. For systems of > 350 kW it is necessary to install a safety filter (recommended in any case) and, if the water has a total hardness of more than 15 French degrees, a water softener to bring the hardness back within the range;
- the filling and topping-up water must be clear and have a total hardness of 15 French degrees.

N.B.: to maintain optimal characteristics of the water in the central heating systems over time, we recommend using and placing specific liquid inhibitors in the circuit.

As for domestic hot water production systems, the standard requires:

- a safety filter to be installed, to protect the systems;
- based on the characteristics of the water, a water softener and/or proportional automatic chemical conditioning dosing system to be installed (food-grade anticorrosive and/or hardness stabilising agents). Treatment systems and points where conditioning agents are added must all be upstream of the hot water generator;
- the following characteristics (appearance - hardness) of the system feed water:
 - a) up to 25 French degrees, in terms of temporary hardness, it is possible to use either softening or hardness and/or anticorrosive chemical stabilisation conditioning;
 - b) softening is compulsory when temporary hardness exceeds 25 French degrees;
 - c) whenever necessary, softening will be integrated with anticorrosive and/or descaling chemical conditioning.

Example of water treatment unit

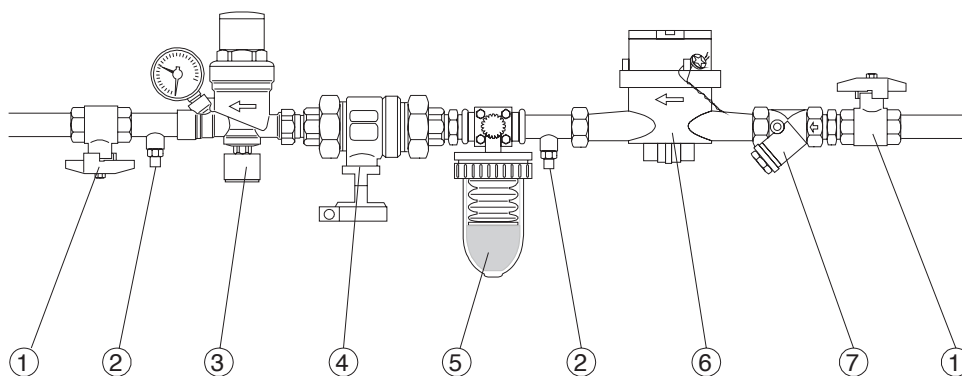

KEY:

- 1 - Ball valve
- 2 - Sample trap
- 3 - Filling unit
- 4 - Disconnector
- 5 - Water treatment unit
- 6 - Litre meter (recommended)
- 7 - "Y" filter

VICTRIX PRO V2 35 - 55 - 60 - 68 - 80 EU

8

HYDRAULIC KIT DIMENSIONS AND CONNECTIONS (OPTIONAL) WITH VICTRIX PRO V2 35 - 55 - 60 - 68 - 80 EU SINGLE BOILER

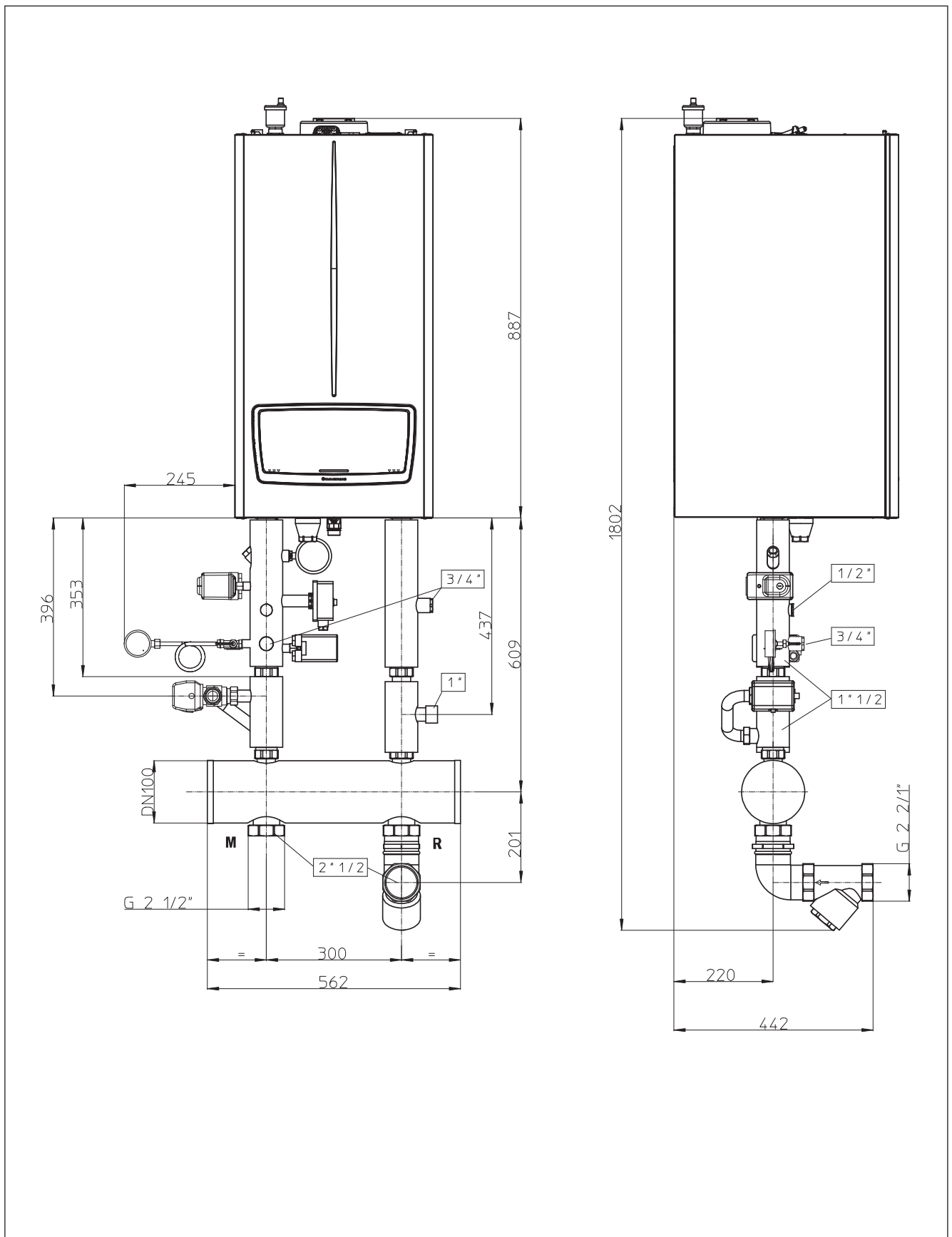

VICTRIX PRO V2 100 - 120 - 150 EU

**8.1 HYDRAULIC KIT DIMENSIONS AND CONNECTIONS (OPTIONAL)
WITH VICTRIX PRO V2 100 - 120 - 150 EU SINGLE BOILER**

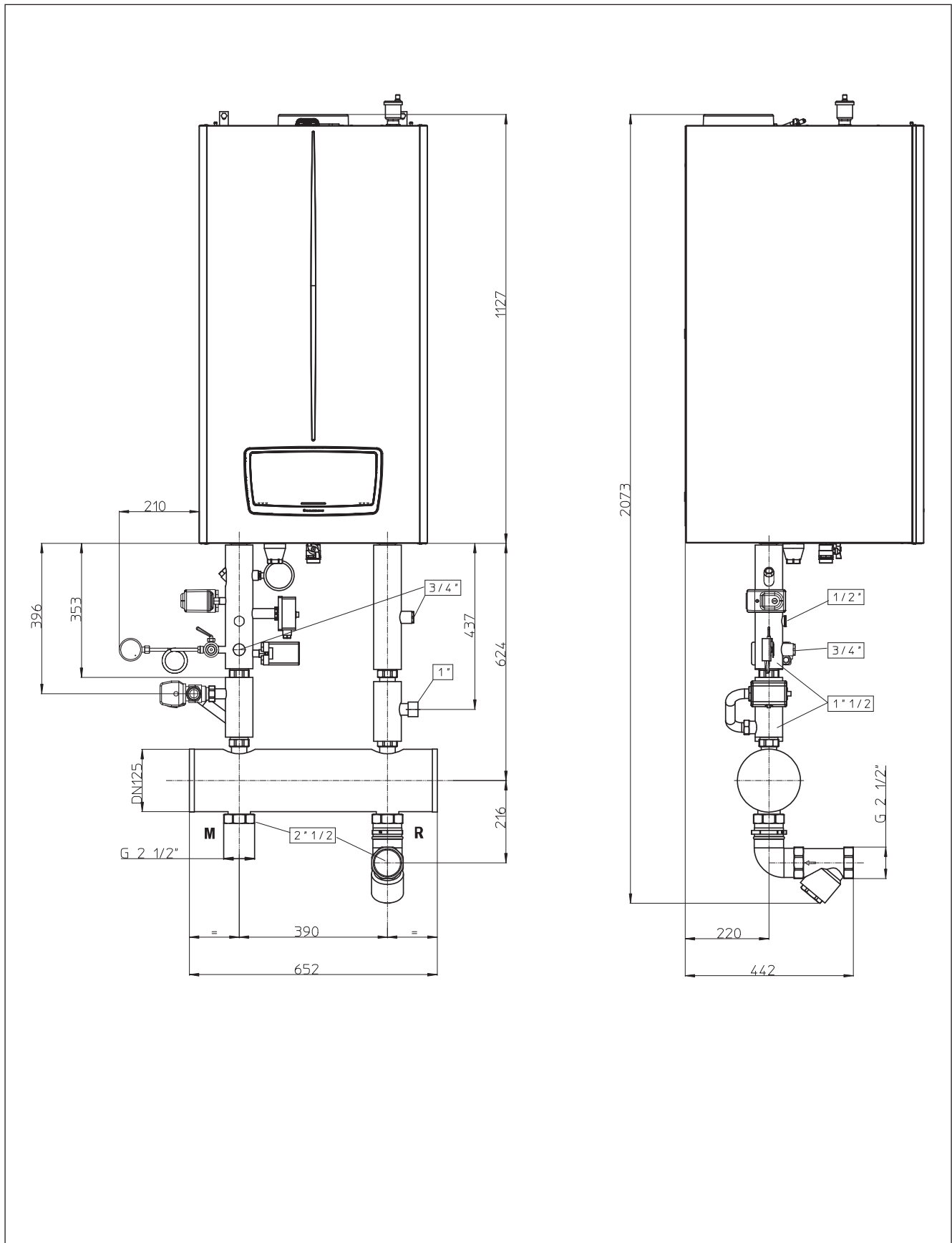

VICTRIX PRO V2 180 EU

8.2 HYDRAULIC KIT DIMENSIONS AND CONNECTIONS (OPTIONAL) WITH VICTRIX PRO V2 180 EU SINGLE BOILER

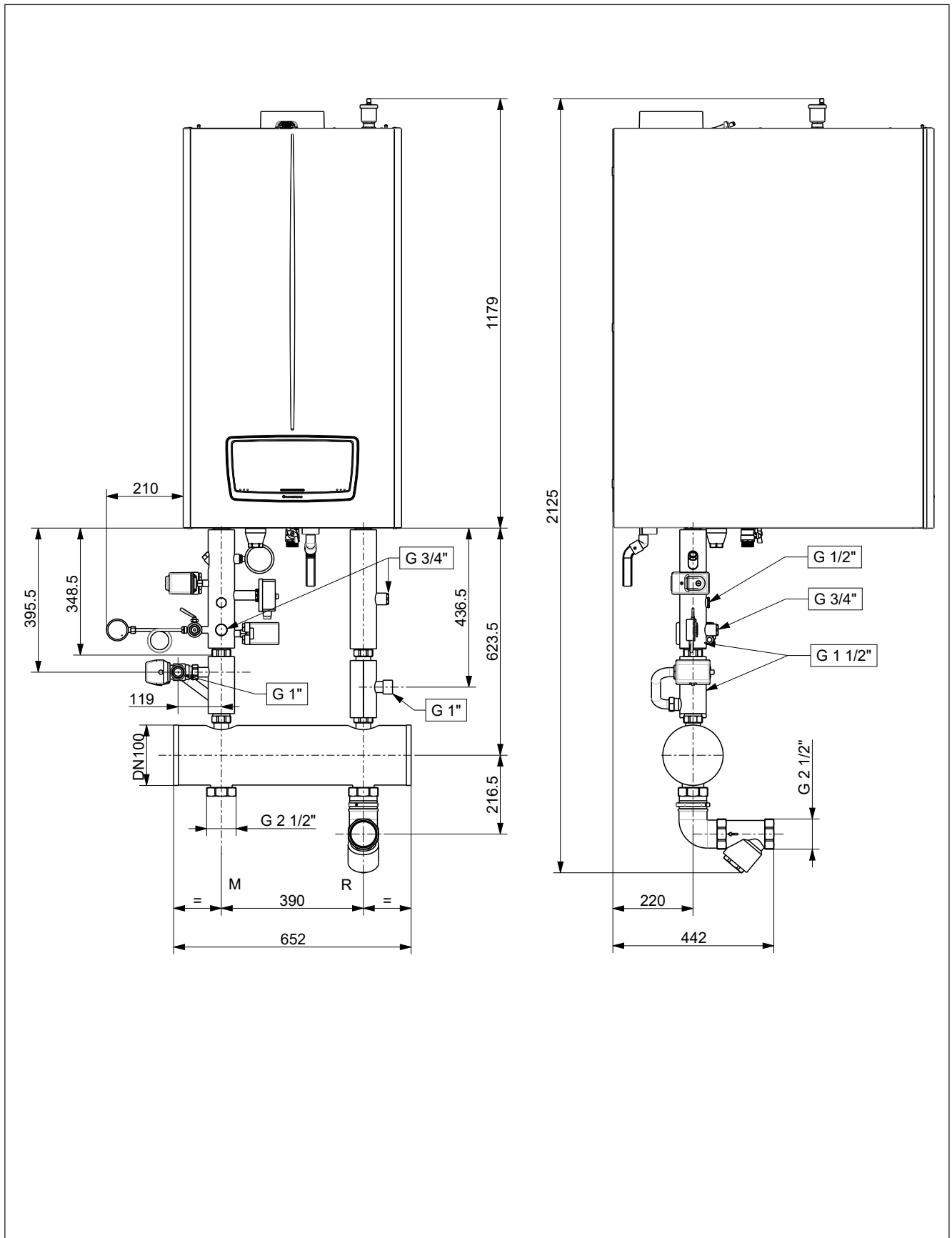

**9 INAIL SAFETY DEVICES KIT FOR SINGLE BOILER
VICTRIX PRO V2 EU**

The safety device kit is INAIL-approved for vertical installation directly under the boiler, placing the relative gaskets in between. With outdoor installation it needs to be protected using the IPX4D protection box kit for INAIL single boiler safety devices, code 3.024028, or nonetheless protected from the elements based on its electrical protection rating.

Immergas S.p.a. declines all liability whenever the installer does not use the devices and INAIL-approved Immergas original kits or uses them improperly.

The sensitive elements of the INAIL safety devices must be set up as described in the installation instructions, in compliance with the provisions set forth in the "R" collection.

Regarding INAIL design, when installing the Immergas safety kits, the following INAIL approved devices are already present:

- Pressure gauge-holder cock;

- Pressure gauge;
 - Thermometer;
 - Manual reset thermostat;
 - Maximum pressure switch and minimum pressure switch, both with manual reset;
- the boiler is already equipped as per standard with a draining funnel with 4 bar Safety valve for VICTRIX PRO V2 35 - 55 - 60 - 68 - 80 EU boilers and 5,4 bar for VICTRIX PRO V2 100 - 120 - 150 and 180 EU boilers.
- There is a fitting for an expansion vessel on the flow and return stub pipes.

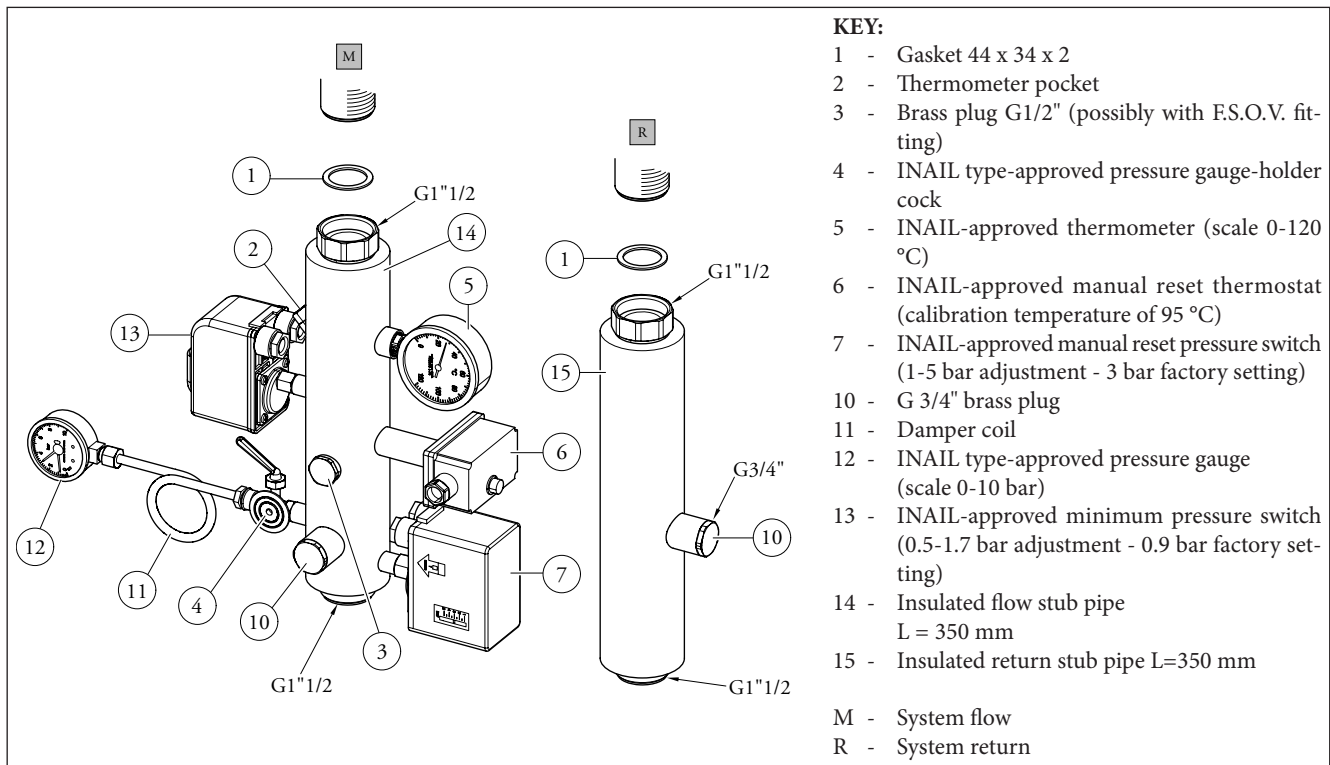

Electrical connection diagram for INAIL safety device kit

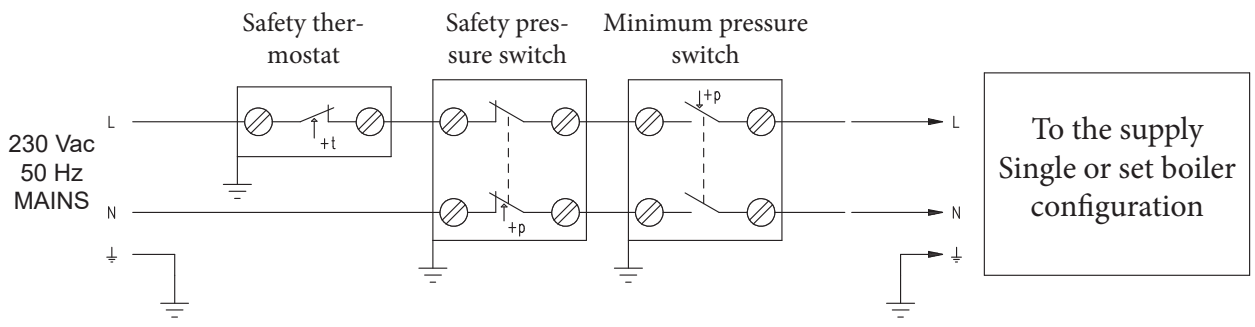

VICTRIX PRO V2 EU

10 THREE-WAY VALVE KIT FOR COMBINATION WITH VICTRIX PRO V2 EU SEPARATE STORAGE TANK UNIT

The kit is sized for single boiler operation or in combination with a separate boiler for DHW production. The output of the boiler in domestic hot water operation must be set based on the heat exchange output of the coil supplied with the storage tank. The diverter valve (which is powered by 230 Vac) comes installed on the flow pipe in combination with a blind manifold (3), reducing the overall installation footprint. The standard kit comes with a NTC probe which needs to be applied to the external storage tank unit and connected to the boiler card (see electrical diagram provided below), removing

any pre-installed temperature probe from the storage tank unit. Kit installation requires the use of an ON-OFF chrono-thermostat for boiler management.

Note: The boiler has an IPX5D electric insulation rating and can also be installed outdoors with cover kit (optional). However, if installed outdoors, the outdoor piping should be insulated and the kit protected from the elements based on its electric protection rating.

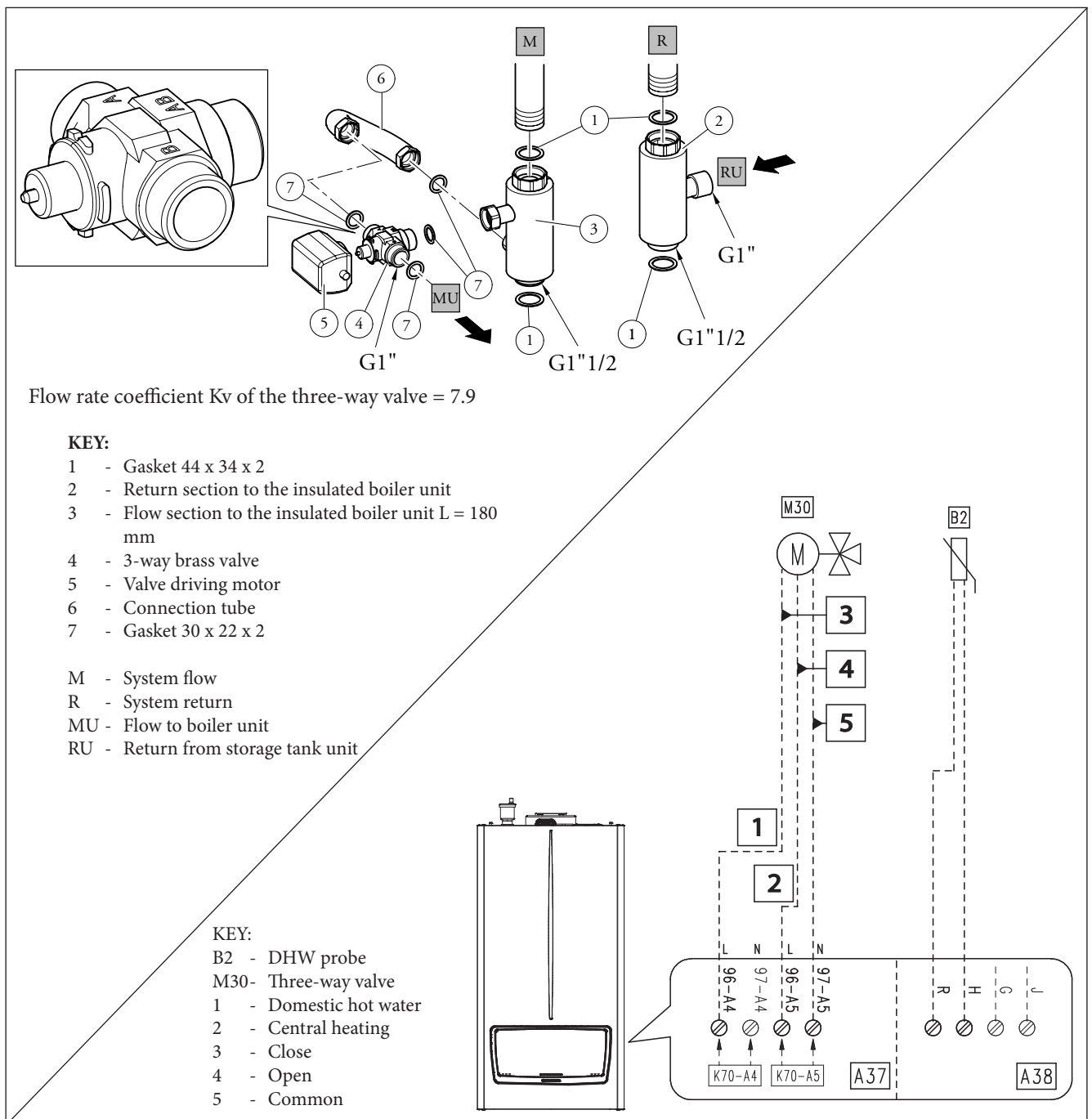

11 HYDRAULIC SEPARATOR KIT FOR VICTRIX PRO V2 EU SINGLE BOILER

The hydraulic separator (compensator) is a particularly significant part inside the hydraulic circuits. It is an open manifold (2) which places system flow and return in communication, creating 2 circuits: a primary circuit (boiler - manifold) and a secondary circuit (manifold-system). The former circulates by the boiler pump, while the latter runs on the correct thermal gradient (and therefore the correct water flow rate), as defined by the system's design. It is advisable to include a hydraulic compensator (2) every time the overall flow rate required by the system is greater than what the boiler is able to supply. The maximum flow rate at the inlet is the generally adopted sizing method.

The brass sludge collecting filter, with relative inspectable stainless steel cartridge, protects the condensation module from getting clogged with the sludge or build-up from the system. **Attention:** The boiler has an electric insulation rating of IPX5D and can also be installed outdoors, whereas the kit must be be appropriately insulated together with its piping.

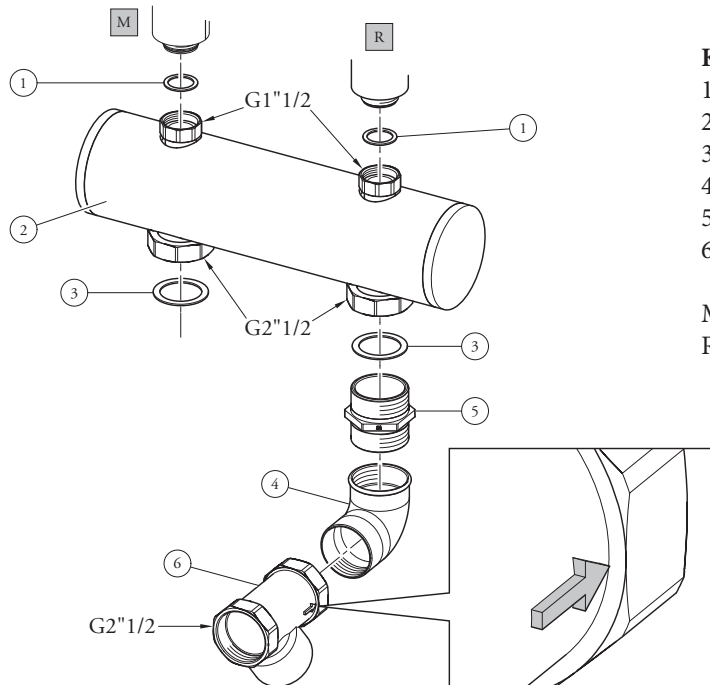

KEY:

- 1 - Gasket 44 x 34 x 2
 - 2 - Insulated Hydraulic manifold DN 100
 - 3 - Gasket 72 X 55 X 2
 - 4 - 90° fitting
 - 5 - Nipple 2" 1/2 M-M
 - 6 - Slurry collection brass filter
- M - Flow
R - Return

Sludge collection filter head loss graph

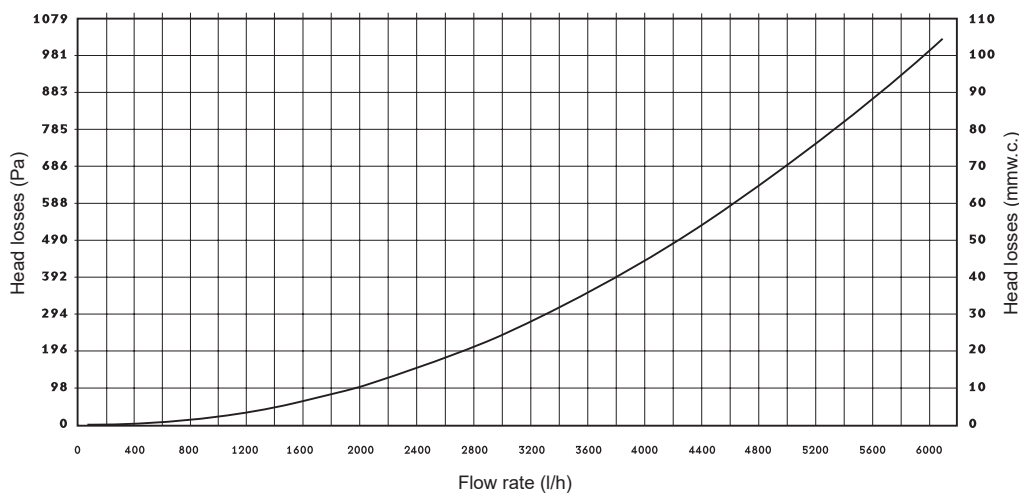

VICTRIX PRO V2 EU

12

PLATE HEAT EXCHANGER KIT FOR VICTRIX PRO V2 EU SINGLE BOILER

Plate heat exchangers, important components of thermal systems and hydraulic circuits, consist of a series of plates appropriately coupled one to the other, which perform fluid separation and thermal exchange between 2 circuits called: Primary and Secondary.

Designed to maximize countercurrent thermal exchange, they are made with 4 connections that put the flow lines in communication with the return lines of each circuit (the primary divided from the secondary).

Circulation is ensured by the generator in the primary circuit, while there are one or more pumps in the secondary circuit which, based on the system design, provide the correct temper-

ature difference so as to exchange the output actually necessary. It is advisable to insert the plate heat exchanger whenever a new generator is installed on an existing system. This keeps the buildup of filth of the existing system from endangering the efficiency and operation of the new generators.

Attention: The boiler has an electric insulation rating of IPX5D and can also be installed outdoors, whereas the kit must be appropriately insulated together with its piping.

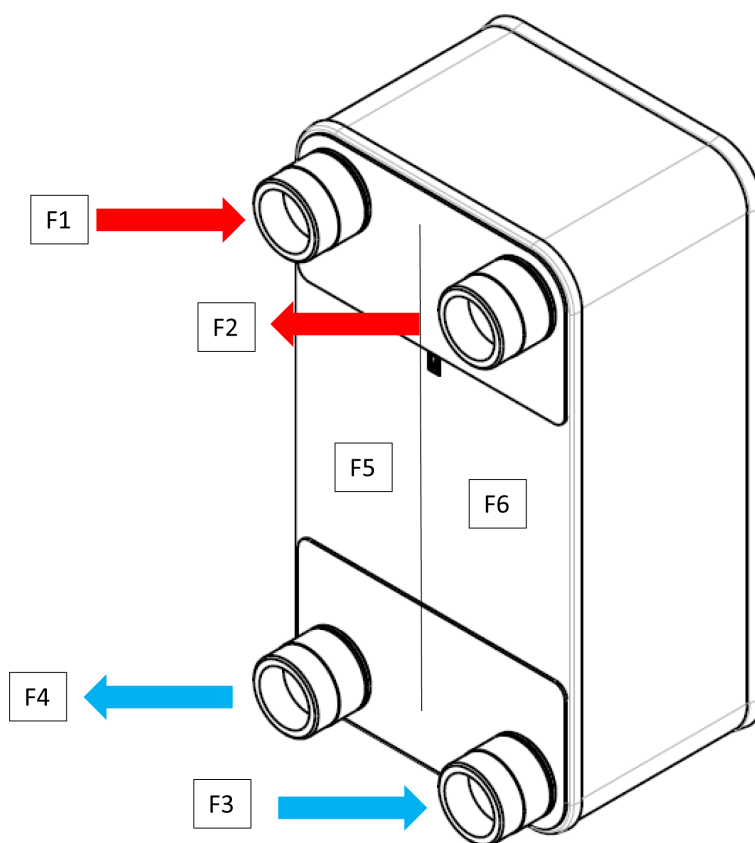

KEY:

- F1 - Flow from boiler
- F2 - Flow to system
- F3 - Return from system
- F4 - Return to boiler
- F5 - Primary boiler
- F6 - Secondary boiler

VICTRIX PRO V2 35 - 55 - 60 - 68 - 80 EU

12.1 DIMENSIONS AND INSTALLATION OF RH PLATE EXCHANGER KIT FOR VICTRIX PRO V2 35 - 55 - 60 - 68 - 80 EU SINGLE BOILER (CODE: 3.033676)

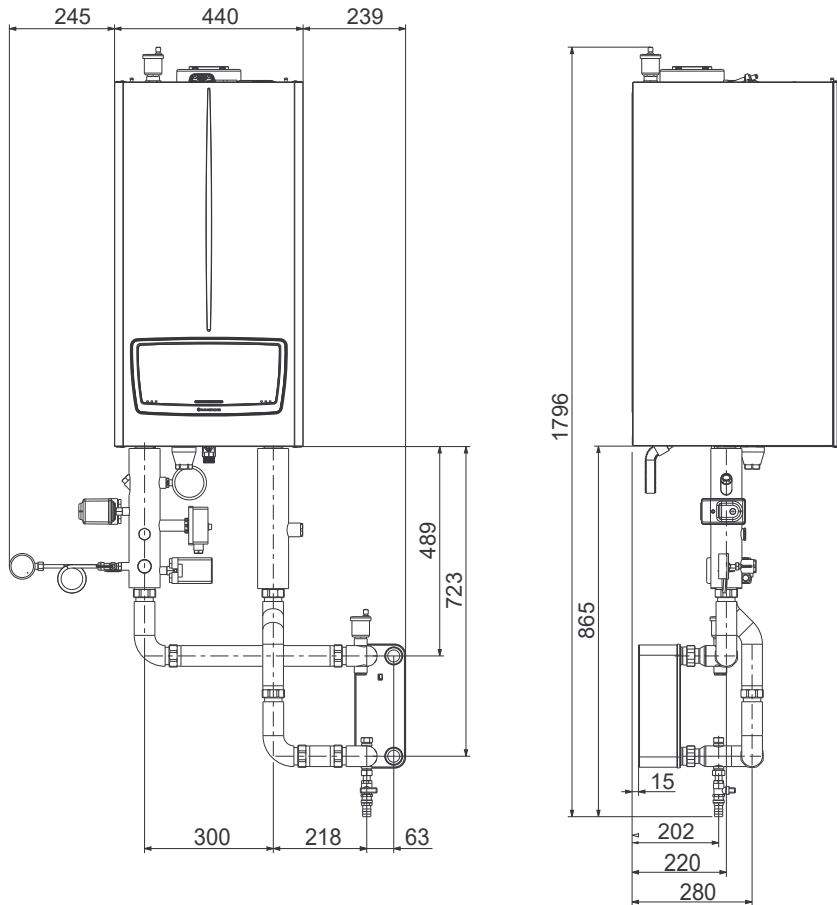

KEY:

- 1 - 2 Gaskets 18.5x11.5x2 AFM 34/2
- 2 - 4 Gaskets 38X28X2 mm in Fasit Soft RG
- 3 - 7 Gaskets 44X34X2 mm in Fasit Soft RG
- 4 - **Plate heat exchanger threaded connections $\text{\O} 1\frac{1}{4}$**
- 5 - O.R. 18X2 Nitrile 70 SH
- 6 - Hose union fitting type Roma fem. $G\frac{1}{2}$ " X15
- 7 - Cock $G\frac{1}{2}$ " M-F with bar hold
- 8 - 50-plate heat exchanger XB12L-1-50
- 9 - Cap $\frac{1}{2}$ " F hex key 23 mm
- 10 - Brass plug Kramer $G\frac{1}{2}$ " male
- 11 - 2 Flow pipes
- 12 - Pipe DN40 $G1\frac{1}{2}$ " L.388
- 13 - Pipe DN40 $G1\frac{1}{2}$ " L.88
- 14 - Pipe DN45 $G2\frac{1}{2}$ " return
- 15 - Pipe DN45 $G2\frac{1}{2}$ " long
- 16 - Pipe DN45 $G2\frac{1}{2}$ " short
- 17 - Automatic air vent valve $\frac{1}{2}$ " mini
- 18 - Boiler

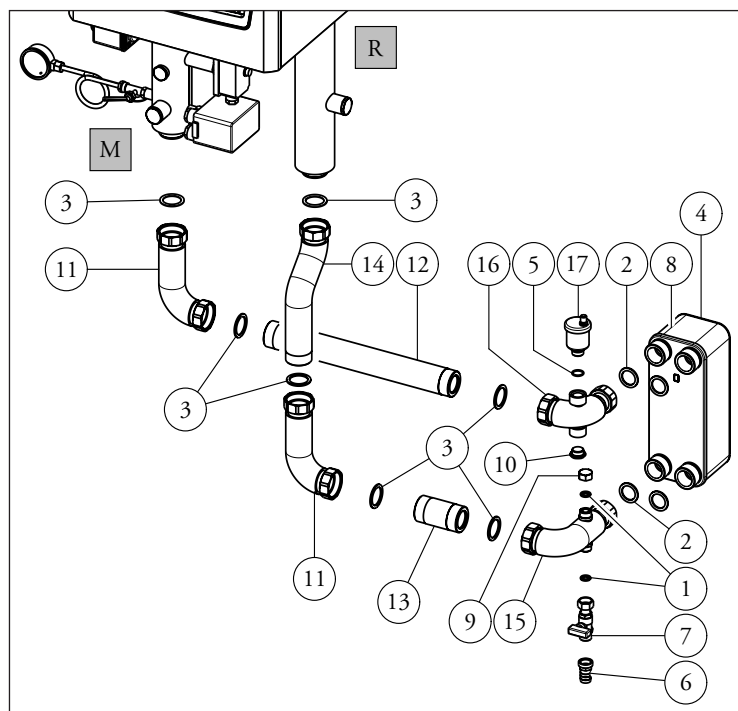

VICTRIX PRO V2 35 - 55 - 60 - 68 - 80 EU

12.2 PLATE HEAT EXCHANGER KIT FOR VICTRIX PRO V2 35 - 55 - 60 - 68 - 80 EU SINGLE BOILER TECHNICAL DATA (CODE: 3.033676)

WATER VOLUMES IN KIT COUPLED WITH:

Model	Primary circuit litre content	Expansion vessel capacity (litres)
VICTRIX PRO V2 35 EU	7.2	2
VICTRIX PRO V2 55 EU	7.6	2
VICTRIX PRO V2 80 EU	8	2

TECHNICAL DATA

Plate heat exchanger coupled with VICTRIX PRO V2 EU (kW)	No. plates	Maximum managed power (kW)	Flow rate Primary (m ³ /h) M/R 80°/60°	Flow rate Secondary (m ³ /h) M/R 70°/55°	Δp (m.w.c.)		Weight of heat exchanger only (kg)
					Primary circuit ΔT 20°C	Secondary circuit ΔT 15°C	
35	50	80	1.5	2.0	0.13	0.21	5.3
55			2.3	3.1	0.33	0.52	
60 - 68 - 80			3.4	4.6	0.70	1.10	

Plate heat exchanger coupled with VICTRIX PRO V2 EU (kW)	No. plates	Maximum managed power (kW)	Flow rate Primary (m ³ /h) M/R 80°/65°	Flow rate Secondary (m ³ /h) M/R 70°/60°	Δp (m.w.c.)		Weight of heat exchanger only (kg)
					Primary circuit ΔT 15°C	Secondary circuit ΔT 10°C	
35	50	80	2.0	3.0	0.24	0.47	5.3
55			3.1	4.7	0.59	1.10	
60 - 68 - 80			4.6	6.9	1.24	2.40	

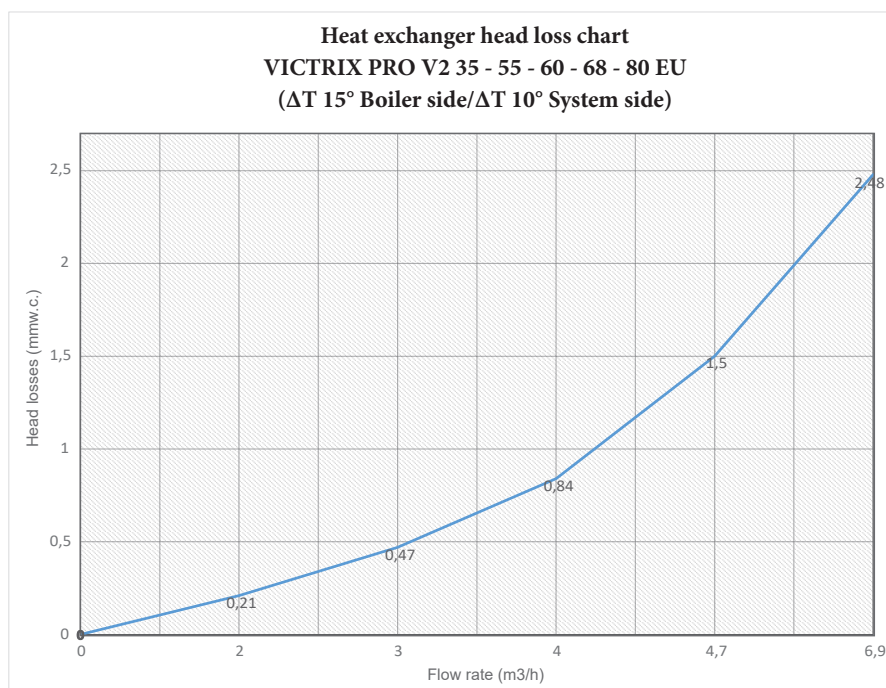

VICTRIX PRO V2 100 - 120 - 150 -180 EU

12.3 DIMENSIONS AND INSTALLATION OF RH PLATE EXCHANGER KIT FOR VICTRIX PRO V2 100 - 120 - 150 - 180 EU SINGLE BOILER (CODE: 3.033677)

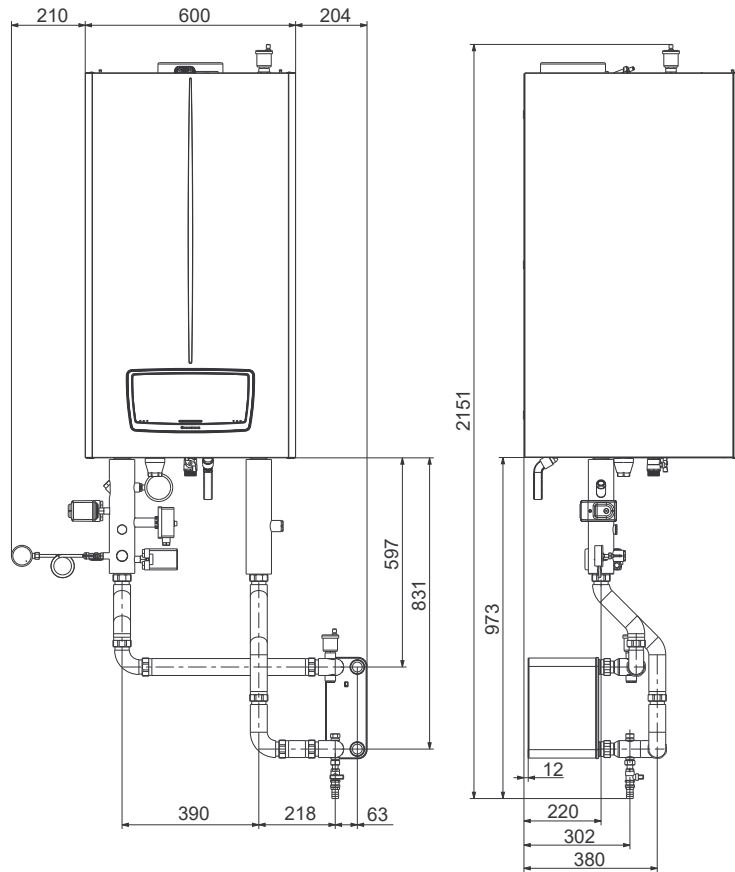

KEY:

- 1 - 2 Gaskets 18.5x11.5x2 AFM 34/2
- 2 - 4 Gaskets 38X28X2 mm in Fasit Soft RG
- 3 - 8 Gaskets 44X34X2 mm in Fasit Soft RG
- 4 - **Plate heat exchanger threaded connections Ø 1" ¼**
- 5 - O.R. 18X2 Nitrile 70 SH
- 6 - Hose union fitting type Roma fem. G½" X15
- 7 - Cock G1/2 M-F with bar hold
- 8 - 110-plate heat exchanger XB12L-1-110
- 9 - Cap G½" F
- 10 - Brass plug Kramer G½" male
- 11 - Pipe DN40 G1" ½ on flow
- 12 - Pipe DN40 G1" ½ L.478
- 13 - Pipe DN40 G1" ½ L.88
- 14 - Pipe DN45 G2" ½ return
- 15 - Pipe DN45 G2" ½ long
- 16 - Pipe DN45 G2" ½ short
- 17 - Pipe DN45 G2" ½ return
- 18 - Set kit flow pipe
- 19 - Automatic air vent valve ½" mini
- 20 - Boiler

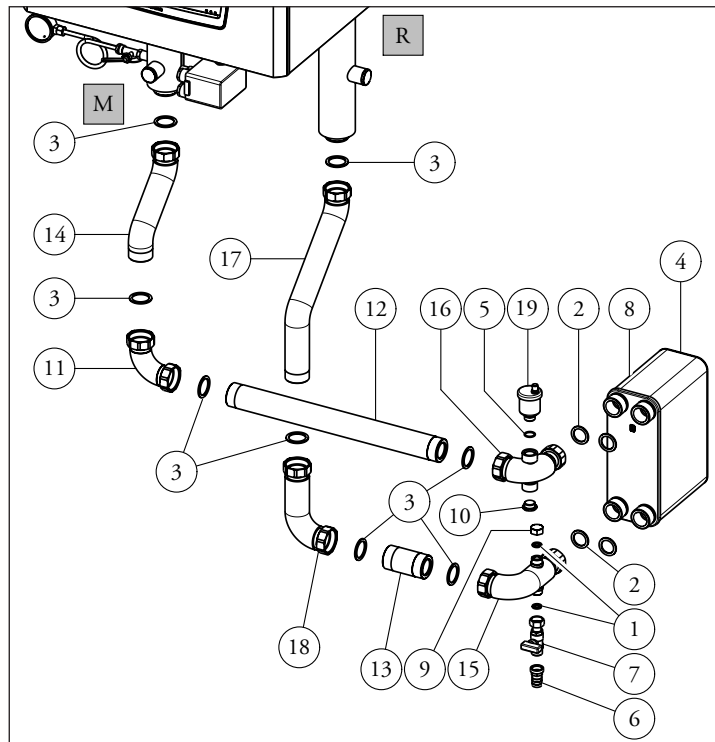

VICTRIX PRO V2 100 - 120 - 150 - 180 EU

12.4 PLATE HEAT EXCHANGER KIT TECHNICAL DATA FOR VICTRIX PRO V2 100 - 120 - 150 - 180 EU SINGLE BOILER (CODE: 3.033677)

WATER VOLUMES IN KIT COUPLED WITH:

Model	Primary circuit litre content	Expansion vessel capacity (litres)
VICTRIX PRO V2 100 EU	15	2
VICTRIX PRO V2 120 EU	16	2
VICTRIX PRO V2 150 EU	18	2
VICTRIX PRO V2 180 EU	21	4

TECHNICAL DATA

Plate heat exchanger coupled with VICTRIX PRO V2 EU (kW)	No. plates	Maximum managed power (kW)	Flow rate Primary (m ³ /h) M/R 80°/60°	Flow rate Secondary (m ³ /h) M/R 70°/55°	Δp (m.w.c.)		Weight of heat exchanger only (kg)
					Primary circuit ΔT 20°C	Secondary circuit ΔT 15°C	
100	110	180	4.3	5.7	0.20	0.43	9.9
120			5.1	6.9	0.29	0.63	
150			6.4	8.6	0.50	0.99	
180			7.3	9.7	0.60	1.25	

Plate heat exchanger coupled with VICTRIX PRO V2 EU (kW)	No. plates	Maximum managed power (kW)	Flow rate Primary (m ³ /h) M/R 80°/65°	Flow rate Secondary (m ³ /h) M/R 70°/60°	Δp (m.w.c.)		Weight of heat exchanger only (kg)
					Primary circuit ΔT 15°C	Secondary circuit ΔT 10°C	
100	110	180	5.7	8.6	0.44	0.98	9.9
120			6.9	10.3	0.64	1.40	
150			8.6	12.9	1.0	2.20	
180			9.7	15.5	1.27	3.18	

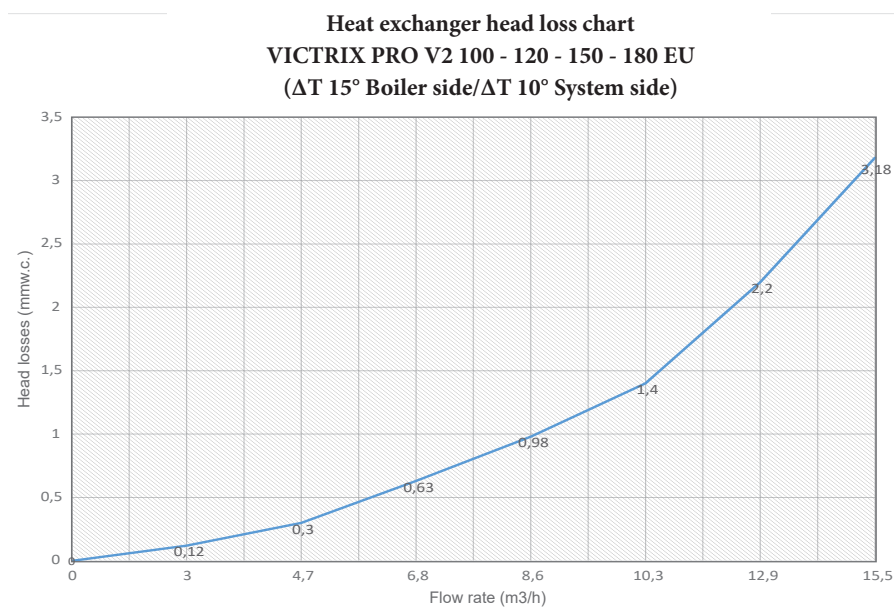

13

SLUDGE REMOVER KIT FOR VICTRIX PRO V2 EU SINGLE INSTALLATION (CODE: 3.033673)

Among the wide range of optionals for new VICTRIX PRO V2 EU generators, Immergas also offers the sludge remover kit for single installation. Designed to capture the filth inside the systems as much as possible, it helps to keep the generator and thermal system

efficient.

It is advisable to insert the sludge remover kit whenever a new generator is installed in an existing system, so as to prevent buildups from jeopardising thermal exchange and operation of the new generators.

Materials.

- Body: brass CW617N - UNI EN 12165
- Filter: stainless steel AISI 304
- Gaskets: EPDM
- Magnet: AlNiCo

Operation:

The flow enters the sludge remover, where it slows down to promote separation of solid impurities inside the fluid. The solid impurities are separated after colliding with the metal mesh (A) and the ferrous materials are held by the force of attraction generated by the magnet (B).

It is possible to clean the filter without needing to disassemble and/or switch off the system, by opening the interception cock (C) and removing the magnet (B) from the containment pocket, pulling it upwards.

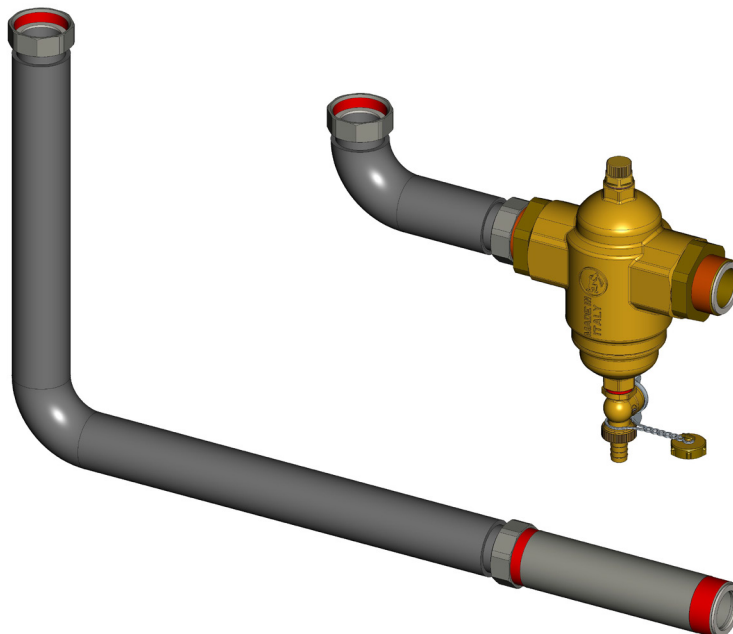
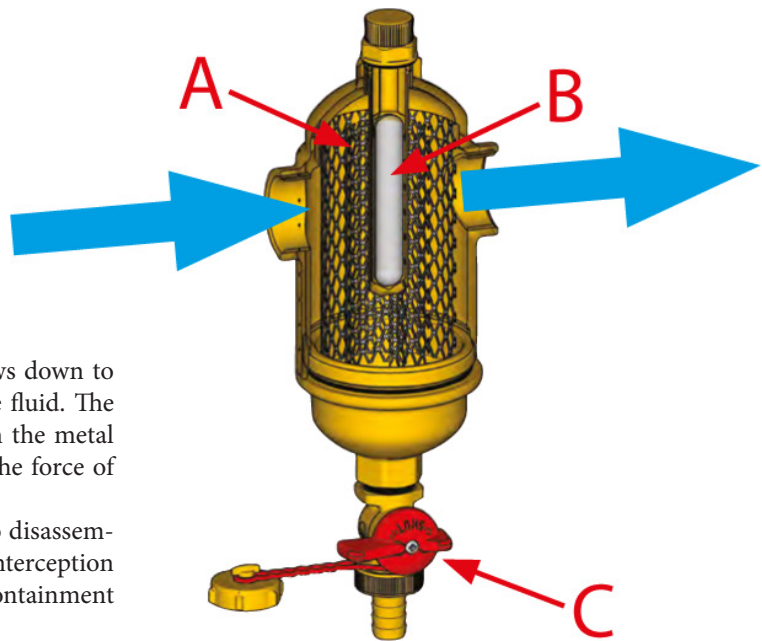

VICTRIX PRO V2 EU

13.1 DIMENSIONS AND CONNECTIONS RH/LH SLUDGE REMOVER KIT FOR VICTRIX PRO V2 EU SINGLE INSTALLATION (CODE: 3.033673)

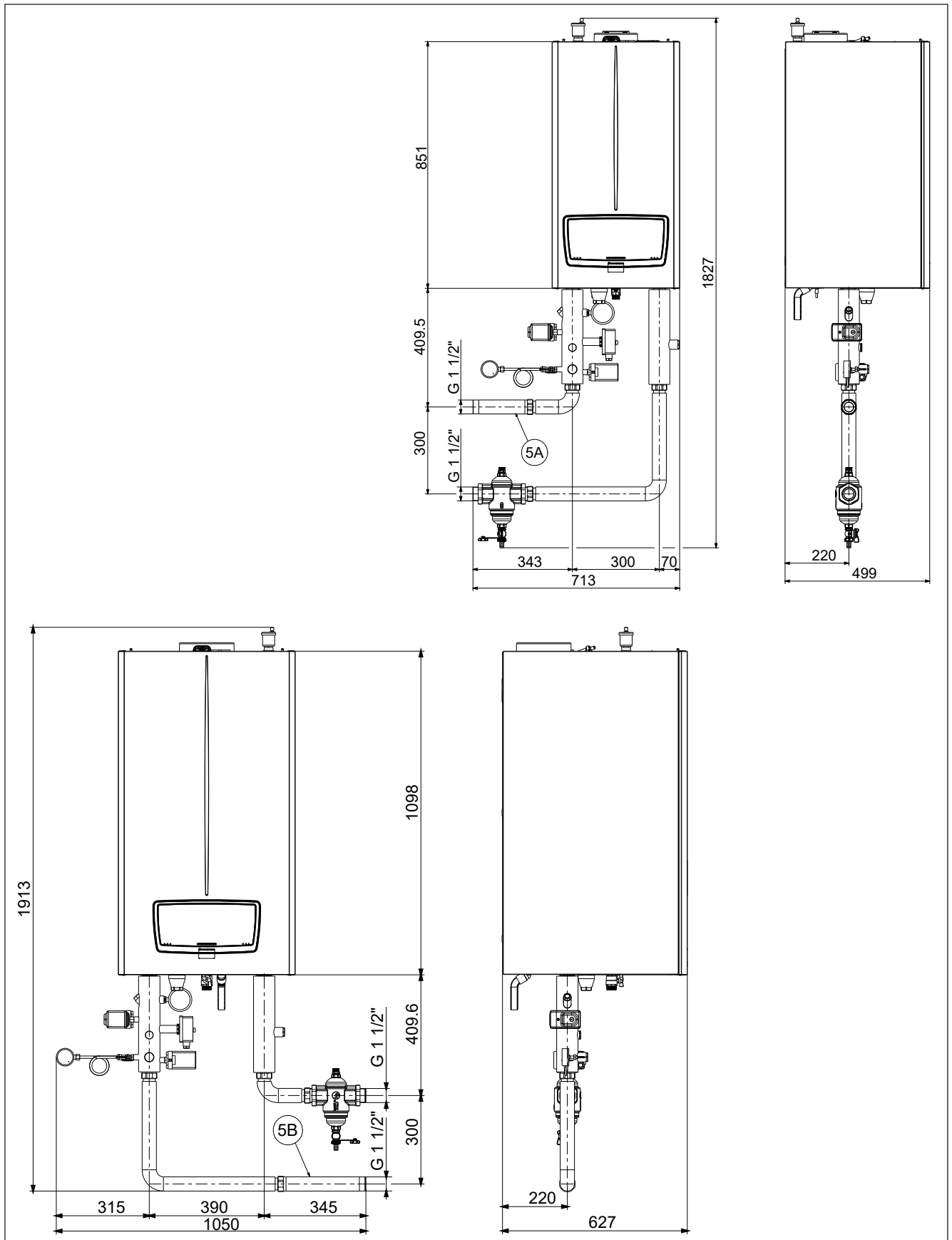

13.2 INSTALLATION OF RH/LH SLUDGE REMOVER KIT FOR VICTRIX PRO V2 EU SINGLE INSTALLATION (CODE: 3.033673)

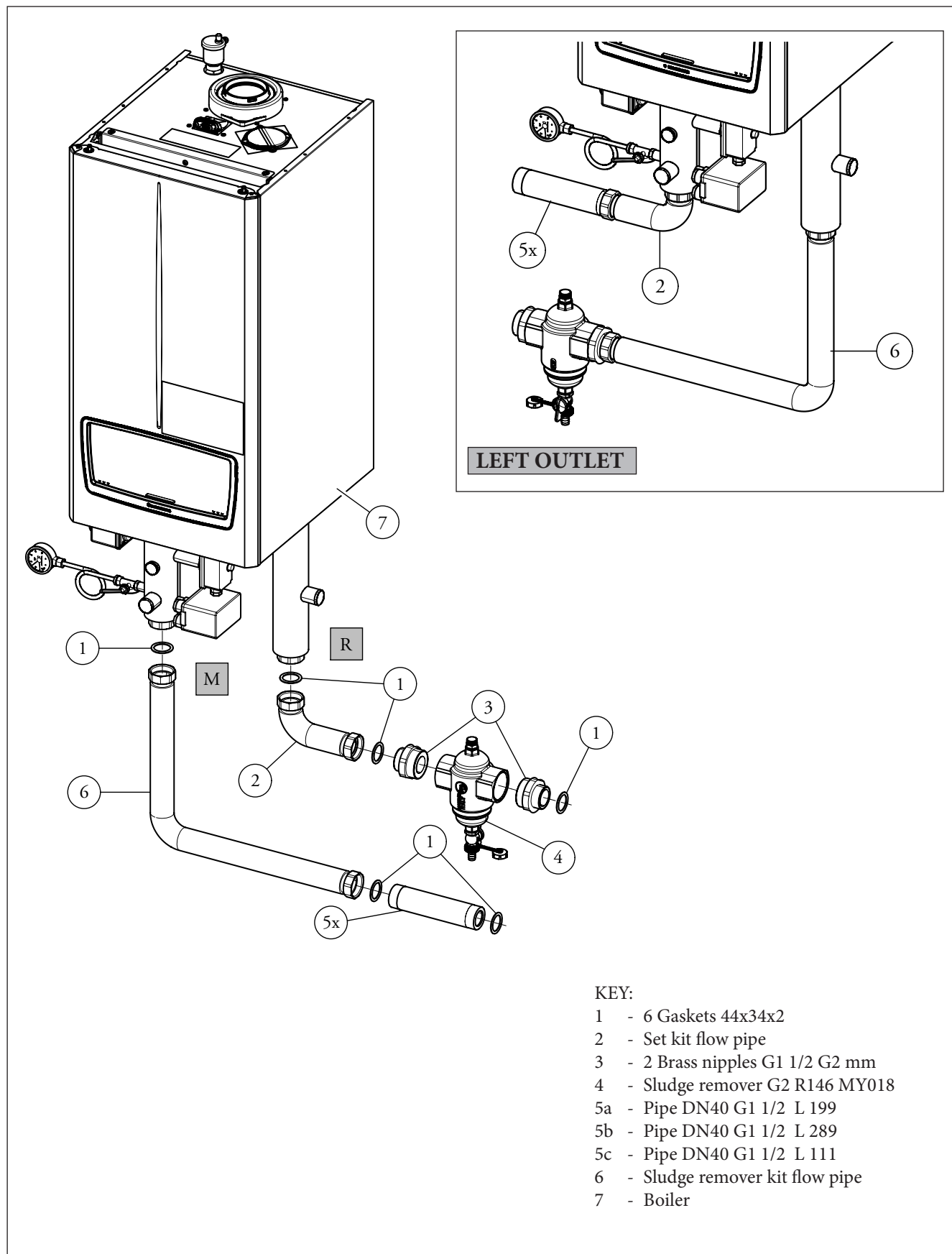

VICTRIX PRO V2 EU

14

OUTDOOR VICTRIX PRO V2 EU CABINET KIT (CODE: 3.033680)



Main features.

The outdoor cabinet kit is supplied for installation and can contain a generator of the VICTRIX PRO V2 range, with the sole exclusion of model VICTRIX PRO V2 180 EU, after adjusting the boiler supports depending on the model (see dimensions and figure on next page).

Constructed with extruded aluminium load-bearing structure, it includes 4 adjustable support feet to ensure stable installation; it can be handled by forklift truck or transpallet to be positioned below the cabinet frame.

Alternatively, you can move the cabinet by means of 4 eyebolts in the upper part.

The cabinet has a door that can be opened to 180° inclusive of lock and it can be installed outdoors.

IT IS also equipped with side holes for connection to the system and a top hole for connection of the flue exhaust pipe. There is a grid opening at the base for the intake of combustion air.

Inside of the cabinet, each generator is installed with its own hydraulic manifold kit for cabinet, including INAIL safety devices (code: 3.033681).

By purchasing several cabinets, you may develop configurations in cascade, with the possibility of making even mixed set configurations.

This is a solution suitable for many applications:

- heating control unit on the roof of the building;
- heating control unit outside the building;
- expansion of existing systems;
- adaptation of non-standardised control units, thanks to the possibility of outdoor application.

Installation.

Level the cabinet by loosening the nuts (pos. 3, Fig. below) and rotating the support feet (pos. 4, Fig. below). Once perfectly level, tighten the nuts loosened previously.

Open the door of the cabinet, loosen the screws (pos. 2, Fig. below) and, depending on the boiler model to be installed, move the boiler supports (pos. 1, Fig. below) as shown in figure.

Once adjusted, tighten the screws that were loosened.

N.B.: The cabinet comes with Ø 80 and Ø 100 clamps to be used according to the flue installed (Ø 80 for VICTRIX PRO V2 35-55-60-68-80 EU models and Ø 100 for VICTRIX PRO V2 100-120-150 EU models).

14.1 OUTDOOR VICTRIX PRO V2 EU CABINET KIT MAIN DIMENSIONS

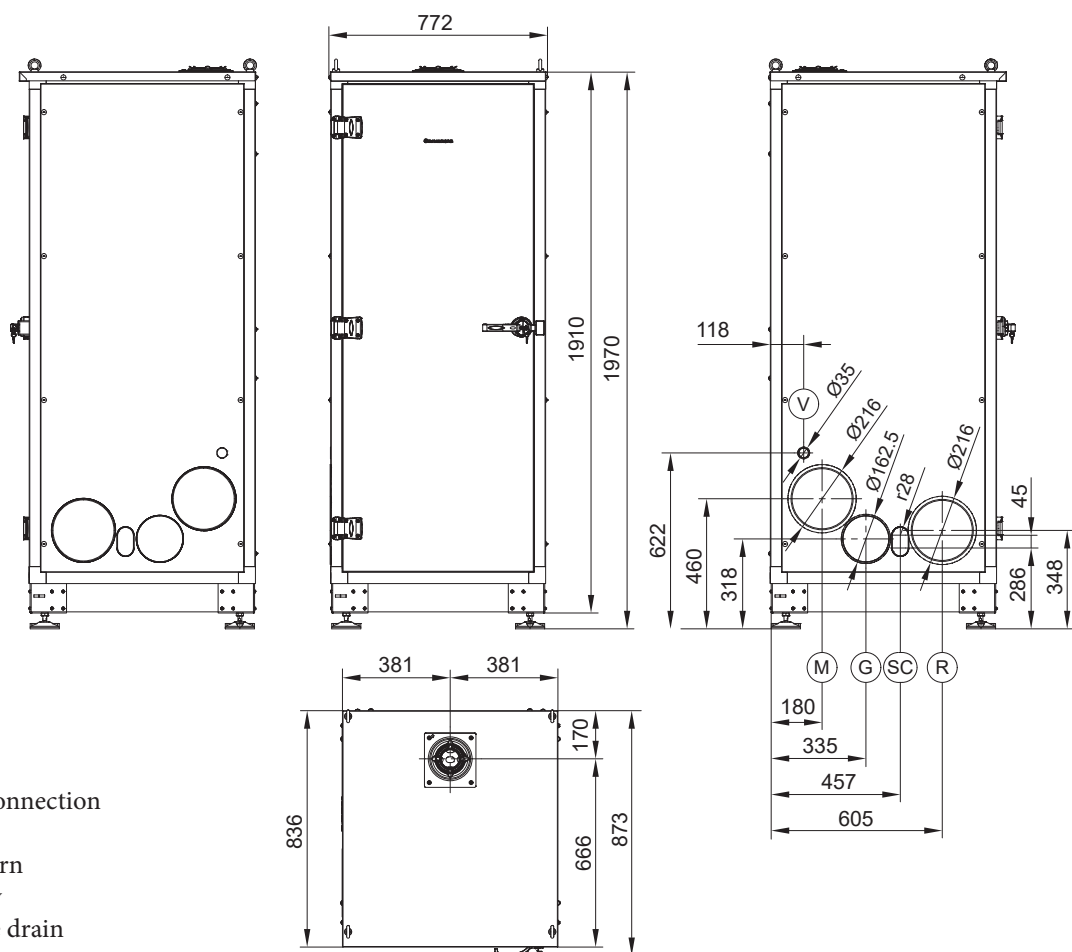

KEY:

- V - Electrical connection
- G - Gas supply
- R - System return
- M - System flow
- SC - Condensate drain

Main dimensions (mm)		
Height with feet	Width	Depth
1970	772	836
Net weight	125 kg	

VICTRIX PRO V2 EU models	y (mm)
35 - 55 - 60 - 68 - 80	340
100 - 120 - 150	470

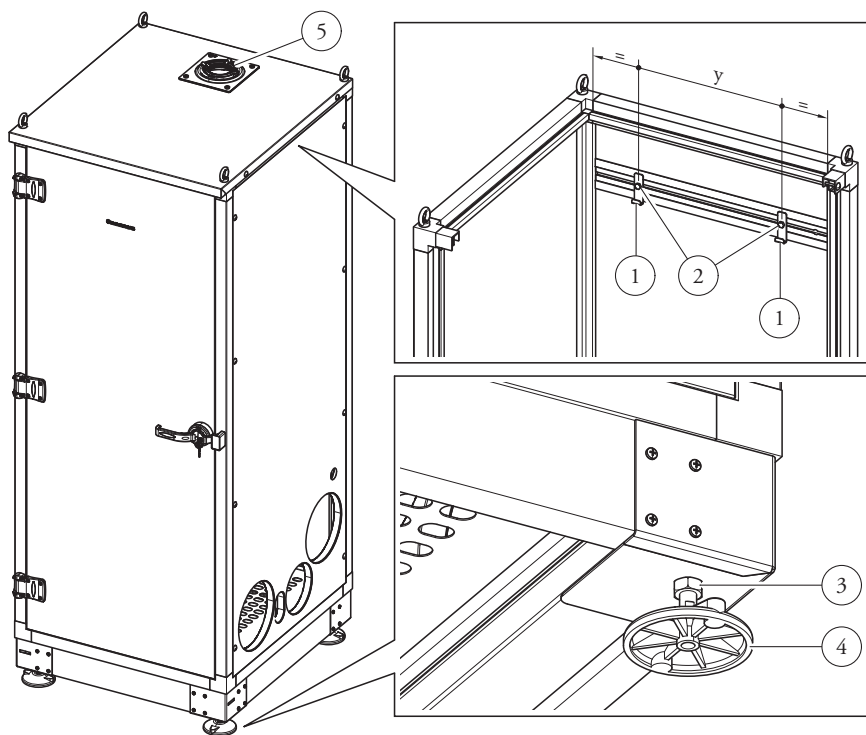

VICTRIX PRO V2 35 - 55 - 60 - 68 - 80 EU

14.2 DIMENSIONS CABINET KIT + SINGLE VICTRIX PRO V2 35 - 55 - 60 - 68 - 80 EU

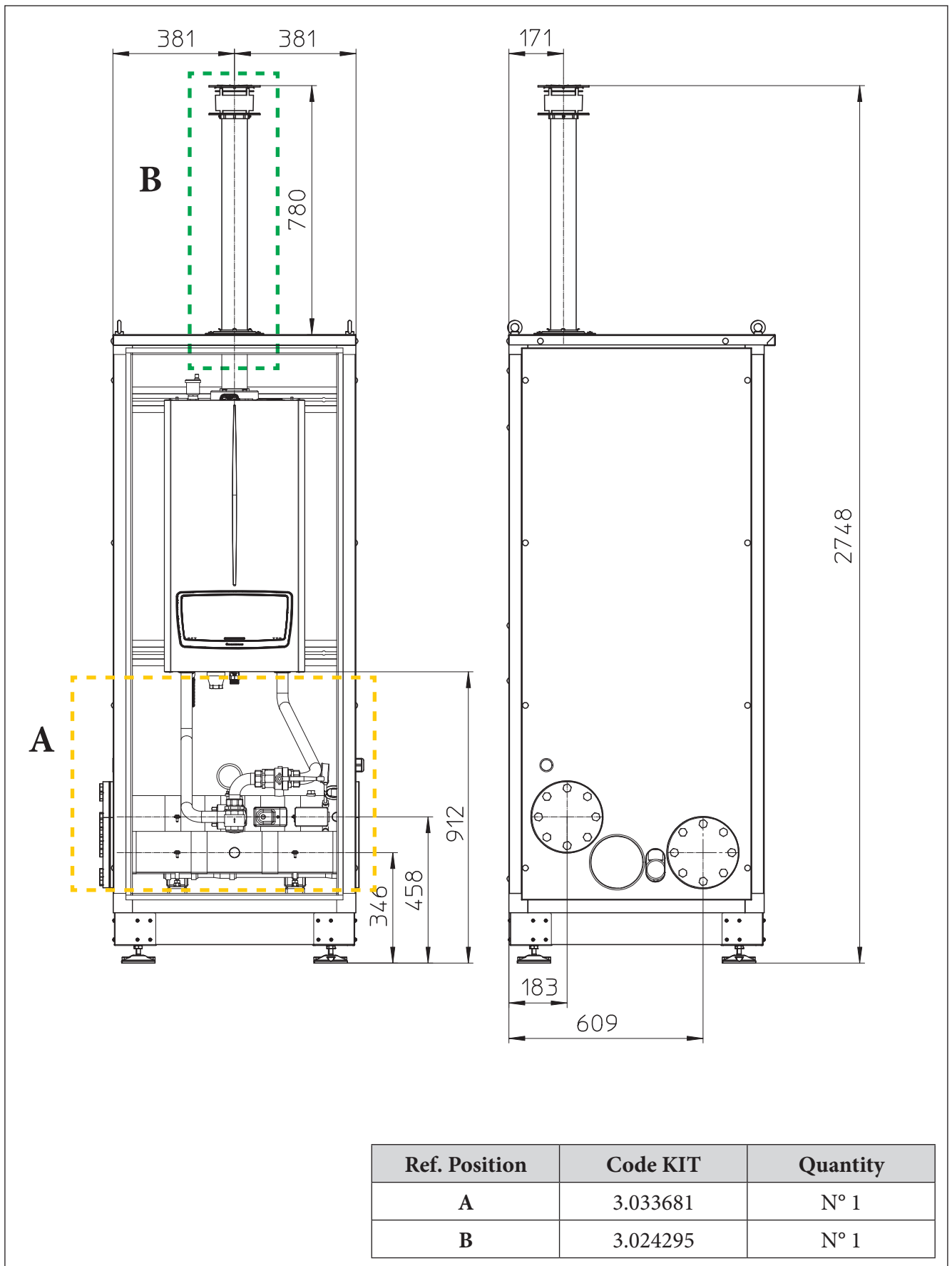

VICTRIX PRO V2 100 - 120 - 150 EU

14.3 DIMENSIONS CABINET KIT + SINGLE VICTRIX PRO V2 100 - 120 - 150 EU

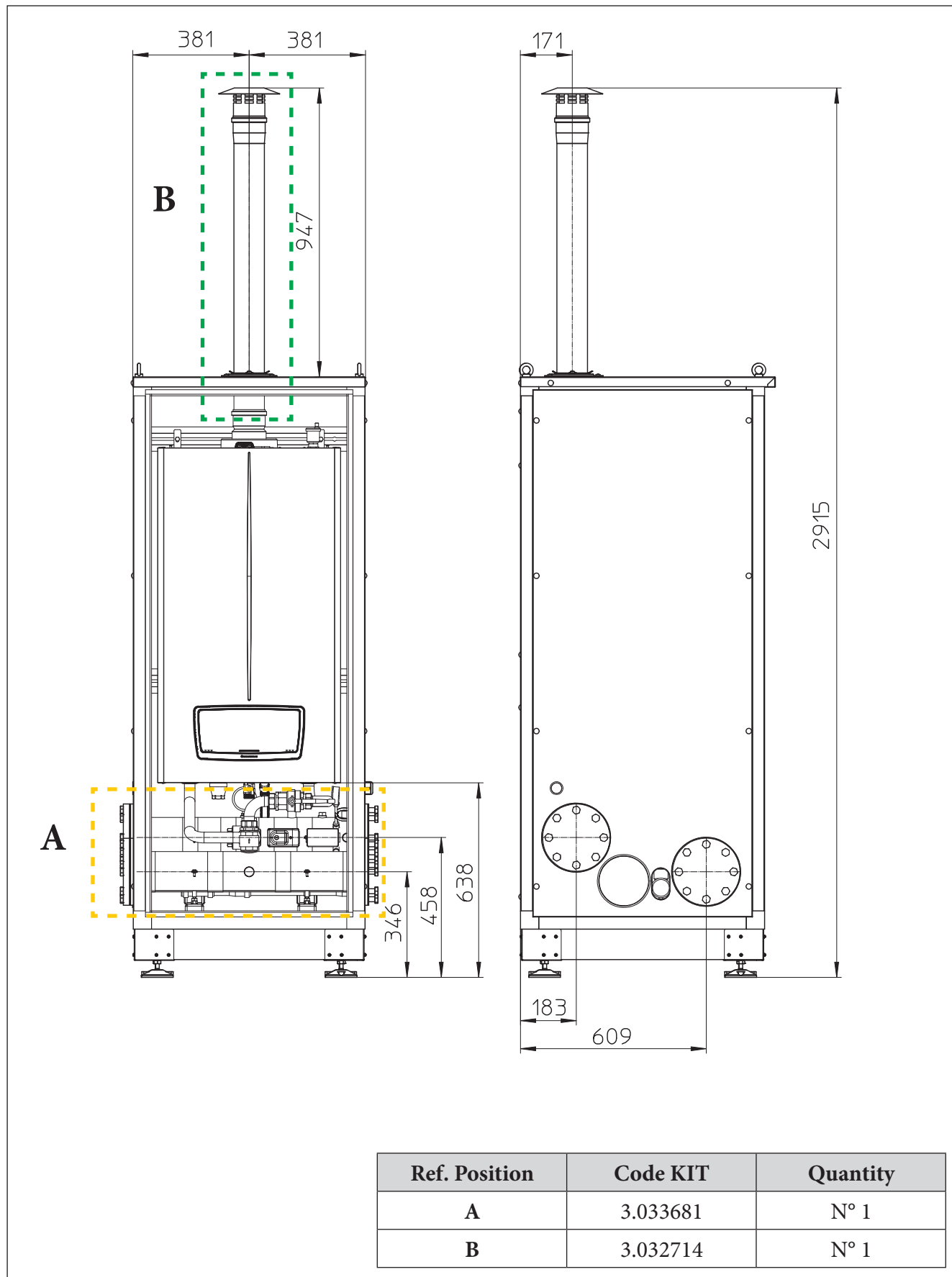

VICTRIX PRO V2 EU

14.4 DIMENSIONS 2 CABINET KIT ALONGSIDE VICTRIX PRO V2 EU IN MIXED OR HOMOGENEOUS SET

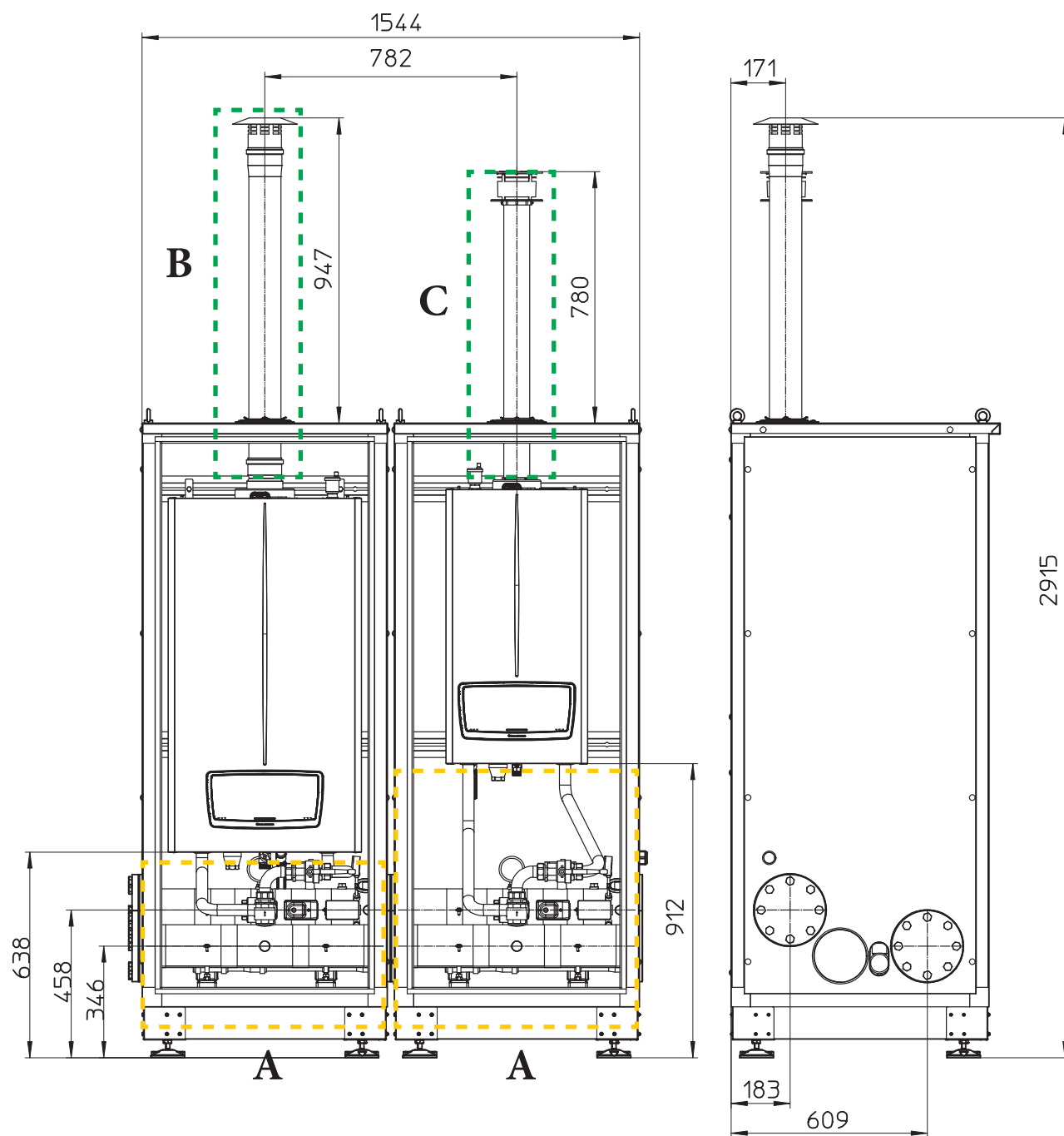

Technical note:

Having the flue exhaust separated and a INAIL safety devices kit for each generator, you can also make mixed sets with VICTRIX PRO V2 Eu generators having different power outputs.

It is not possible to use flue manifolds for boilers in set configuration.

Ref. Position	Code KIT	Quantity
A	3.033681	N° 2
B	3.032714	N° 1
C	3.024295	N° 1

VICTRIX PRO V2 35 - 55 - 60 - 68 - 80 EU

15 VICTRIX PRO V2 35 - 55 - 60 - 68 - 80 EU ADAPTER KIT TO REPLACE FIRST RANGE OF WALL-HUNG BOILERS IN SINGLE CONFIGURATION (CODE: 3.023966)

This kit is composed of just two gaskets 44x34x2 (1) and two insulated pipes (2), to compensate for the variation in the centre distances between flow and return on VICTRIX PRO V2 35 - 55 - 60 - 68 - 80 EU boilers, which is 300 mm in comparison to the centre distance between flow and return on the first range of high output wall-hung boilers (e.g. VICTRIX 50-75), which is 390 mm.

Accordingly, it is possible to install VICTRIX PRO V2 35 - 55 - 60 - 68 - 80 EU models in place of the models from the first range of VICTRIX 50-75 wall-hung boilers in single configuration.

The elements illustrated in the figure and any INAIL safety kit for single boilers must be installed according to the relative documents of reference.

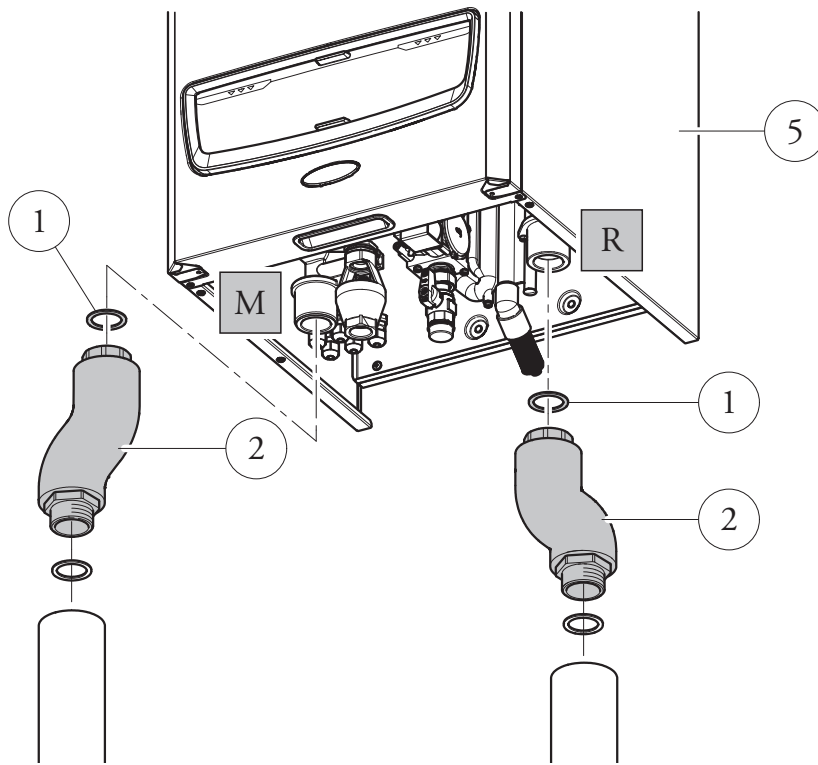

KEY:

- 1 - 44x34x2 gasket
- 2 - Insulated adaptation pipe
- 5 - Generator

- M - Flow
- R - Return

VICTRIX PRO V2 35 - 55 - 60 - 68 - 80 EU

16 KIT DIMENSIONS AND CONNECTIONS (OPTIONAL) FOR VICTRIX PRO V2 35 - 55 - 60 - 68 - 80 EU MODULES IN SET CONFIGURATION (MAXIMUM 5 APPLIANCES)

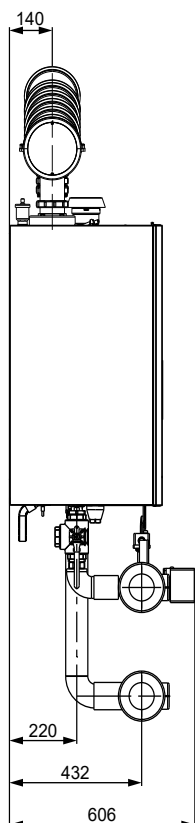
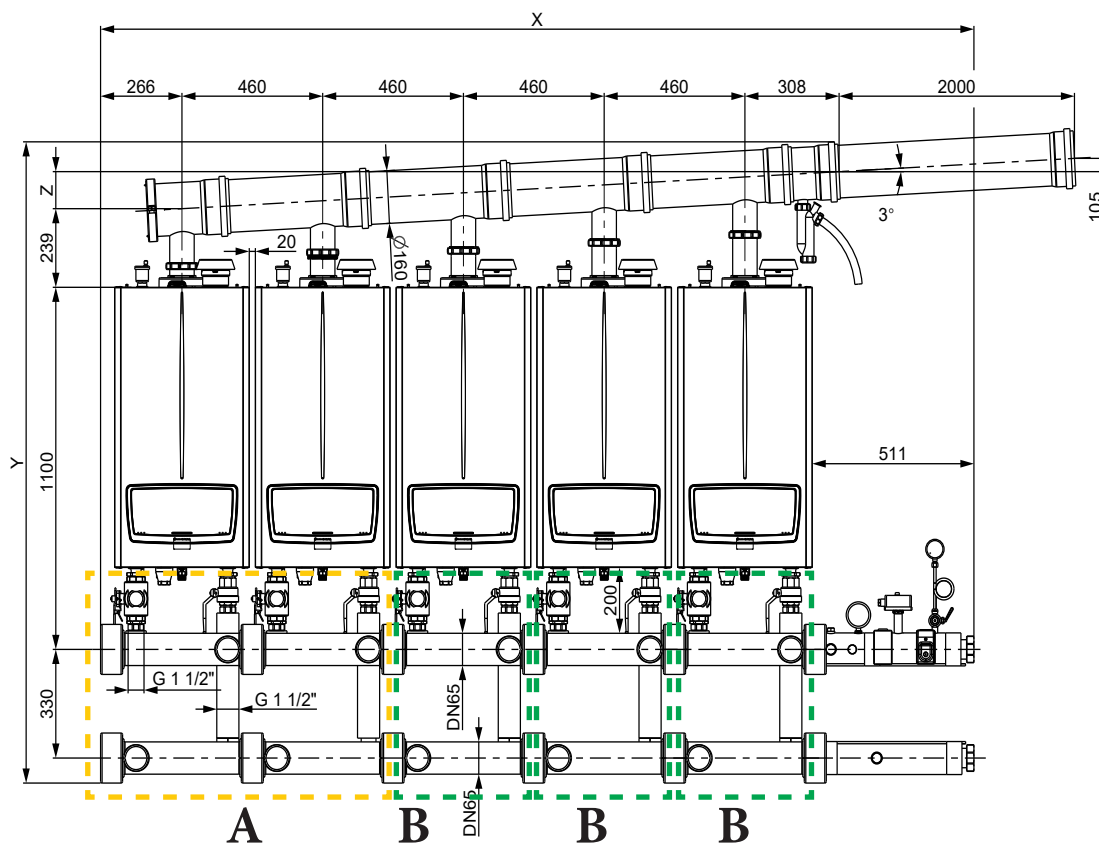

Reference	2 boilers	3 boilers	4 boilers	5 boilers
X	1456 mm	1916 mm	2376 mm	2836 mm
Y	1876 mm	1900 mm	1924 mm	1948 mm
Z	41 mm	65 mm	89 mm	113 mm
Ø	160 mm	160 mm	160 mm	160 mm

Ref. Position	Code KIT
A	3.032338
B	3.033669

Technical note

Hydraulic manifolds (optional) are equipped with non return valve and 3-way valve on the flow pipe of each thermal module and 2-way shut off valve on the return pipe to the thermal module.

Inserting the 3-way valve on the flow pipe of the thermal module puts it in communication with the proper heat carrying fluid exhaust system in the module itself to perform extraordinary maintenance.

VICTRIX PRO V2 100 - 120 - 150 EU

16.1 KIT DIMENSIONS AND CONNECTIONS (OPTIONAL) FOR VICTRIX PRO V2 100 - 120 EU MODULES IN SET CONFIGURATION (MAXIMUM 5 APPLIANCES)

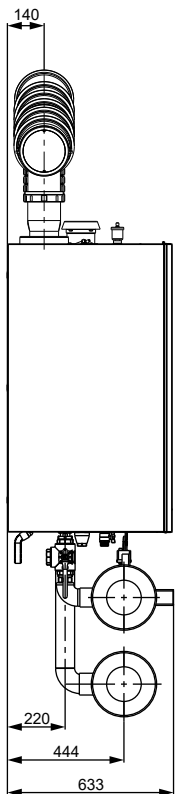
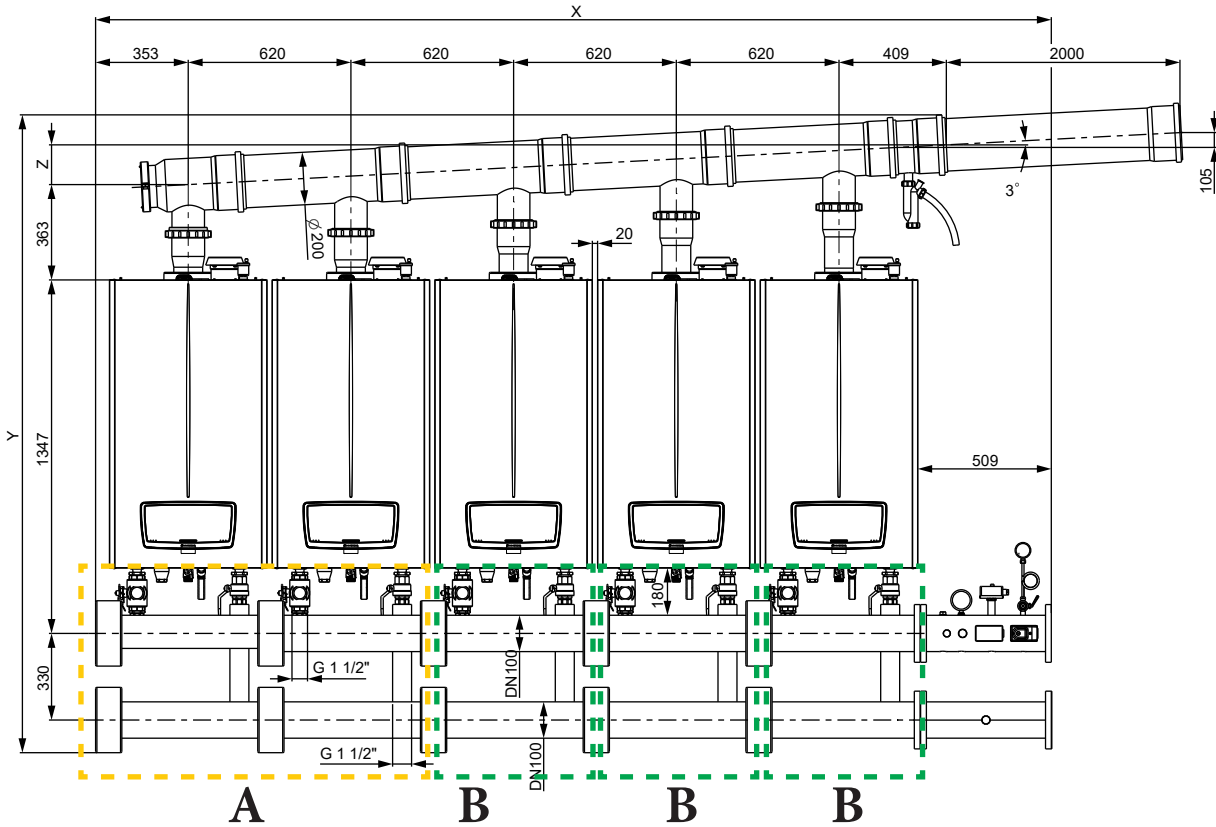

Reference	2 boilers	3 boilers	4 boilers	5 boilers
X	1783 mm	2403 mm	3023 mm	3643 mm
Y	2335 mm	2367 mm	2399 mm	2431 mm
Z	55 mm	87 mm	119 mm	151 mm
Ø	200 mm	200 mm	200 mm	200 mm

Ref. Position	Code KIT
A	3.033667
B	3.033668

Technical note

Hydraulic manifolds (optional) are equipped with non return valve and 3-way valve on the flow pipe of each thermal module and 2-way shut off valve on the return pipe to the thermal module.

Inserting the 3-way valve on the flow pipe of the thermal module puts it in communication with the proper heat carrying fluid exhaust system in the module itself to perform extraordinary maintenance.

VICTRIX PRO V2 100 - 120 - 150 EU

16.2 KIT DIMENSIONS AND CONNECTIONS (OPTIONAL) FOR VICTRIX PRO V2 150 EU MODULES IN SET CONFIGURATION (MAXIMUM 5 APPLIANCES)

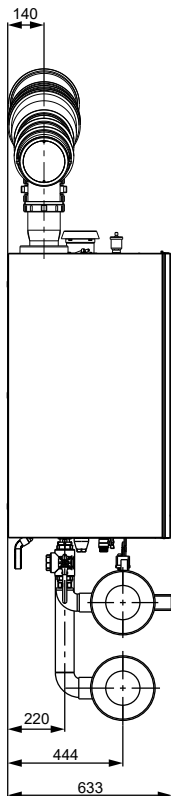
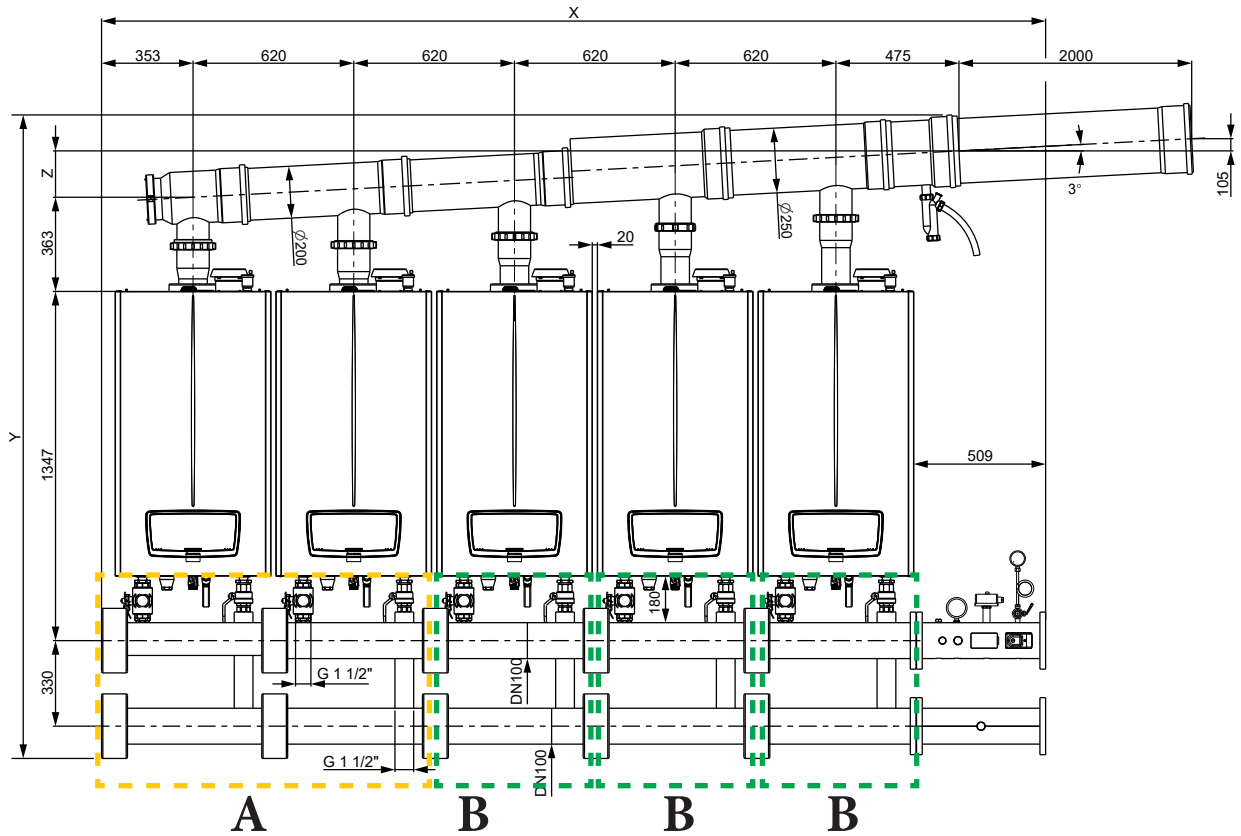

Reference	2 boilers	3 boilers	4 boilers	5 boilers
X	1782 mm	2402 mm	3022 mm	3642 mm
Y	2343 mm	2375 mm	2455 mm	2482 mm
Z	59 mm	91 mm	147 mm	179 mm
Ø	200 mm	200 mm	250 mm	250 mm

Ref. Position	Code KIT
A	3.033667
B	3.033668

Technical note

Hydraulic manifolds (optional) are equipped with non return valve and 3-way valve on the flow pipe of each thermal module and 2-way shut off valve on the return pipe to the thermal module.

Inserting the 3-way valve on the flow pipe of the thermal module puts it in communication with the proper heat carrying fluid exhaust system in the module itself to perform extraordinary maintenance.

16.3 KIT DIMENSIONS AND CONNECTIONS (OPTIONAL) FOR VICTRIX PRO V2 180 EU MODULES IN SET CONFIGURATION (MAXIMUM 5 APPLIANCES)

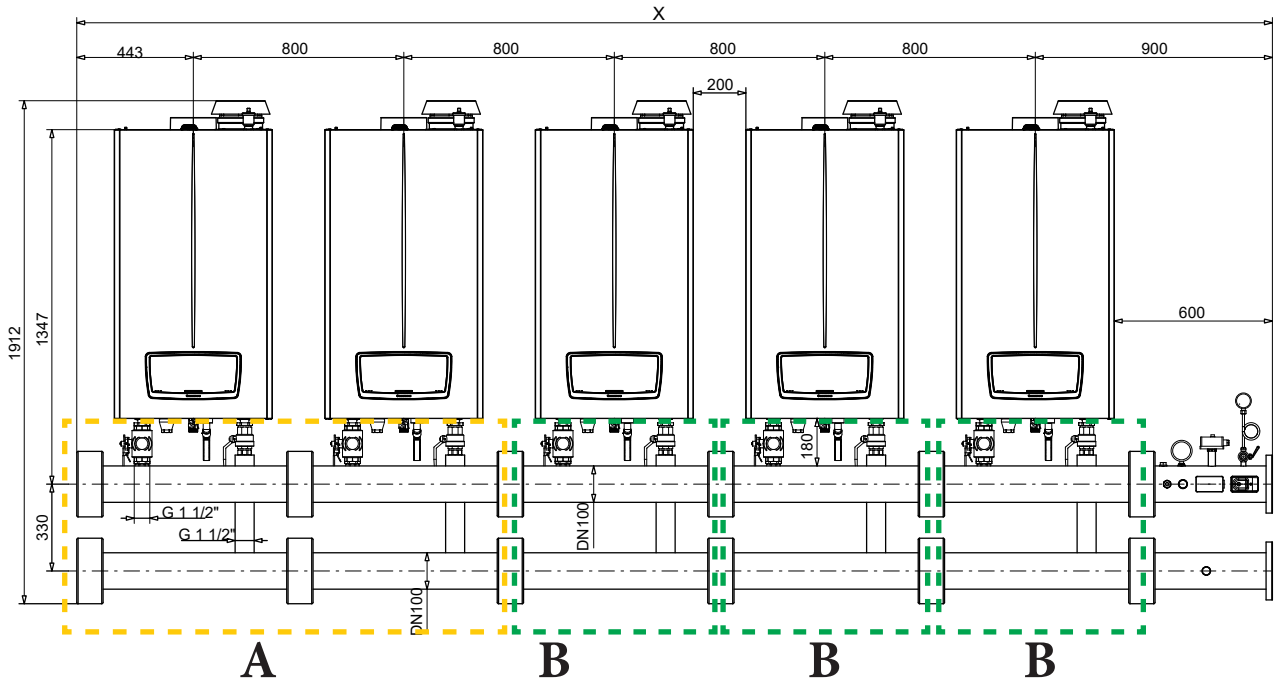

Reference	2 boilers	3 boilers	4 boilers	5 boilers
X	2143 mm	2943 mm	3743 mm	4543 mm

Ref. Position	Code KIT
A	3.034938
B	3.034939

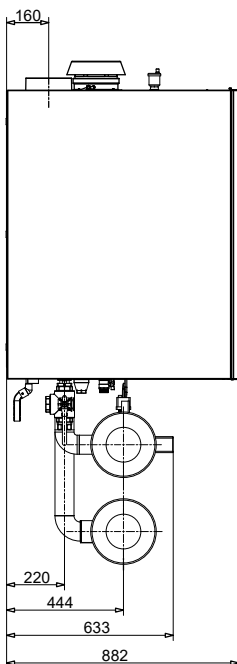

Technical note

In this configuration, for VICTRIX PRO V2 180 EU modules in cascade, Immergas does not supply either flue manifolds or clapet valves.

Hydraulic manifolds (optional) are equipped with non return valve and 3-way valve on the flow pipe of each thermal module and 2-way shut off valve on the return pipe to the thermal module.

Inserting the 3-way valve on the flow pipe of the thermal module puts it in communication with the proper heat carrying fluid exhaust system in the module itself to perform extraordinary maintenance.

VICTRIX PRO V2 35 - 55 - 60 - 68 - 80 EU

17

INSTALLATION OF HYDRAULIC MANIFOLD KIT (OPTIONAL) AT RH/LH IN SET CONFIGURATION VICTRIX PRO V2 35 - 55 - 60 - 68 - 80 EU

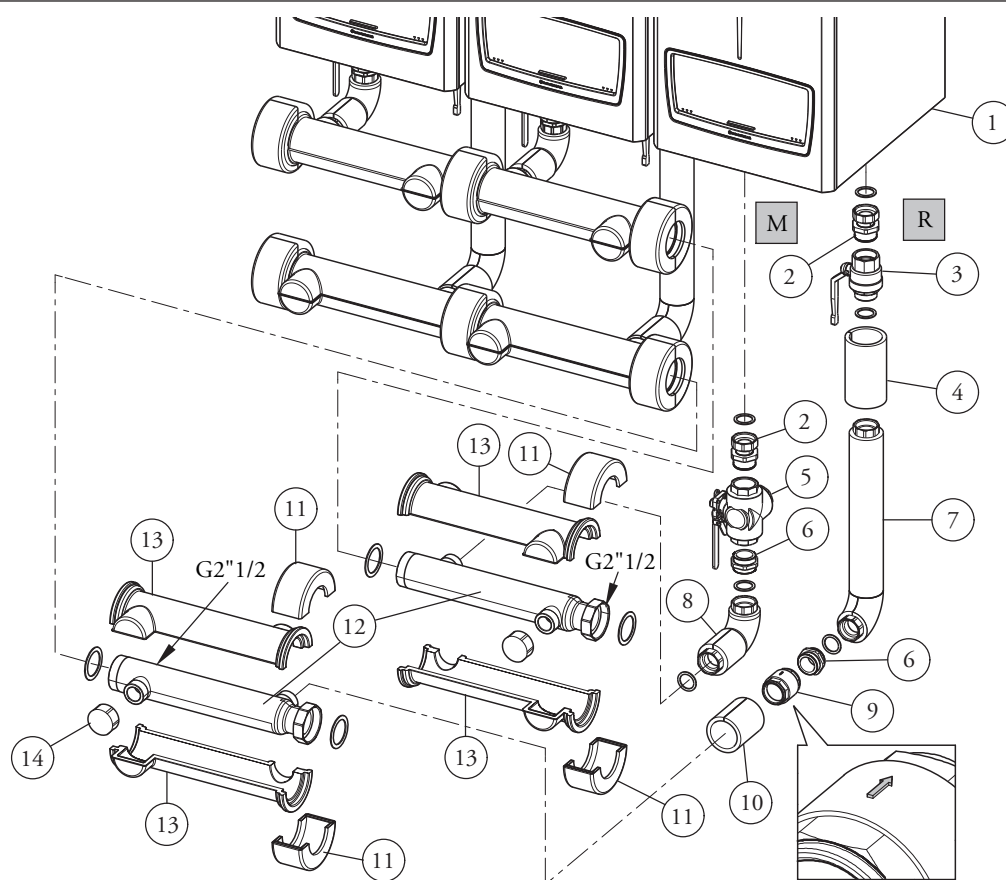

KEY:

- | | |
|--|--------------------------------|
| 1 - Thermal modules in set configuration | 8 - Insulated 90° bend in flow |
| 2 - 2 Valve fixing fittings | 9 - Non return valve |
| 3 - Ball valve | 10 - Insulation |
| 4 - Insulation | 11 - Insulation half-shell |
| 5 - 3-way valve | 12 - 2 Manifolds G 2" ½ |
| 6 - 2 Nipples | 13 - Insulation half-shell |
| 7 - Long insulated 90° bend in return | 14 - 2 Caps C1" ½ |

Modules	Hydraulic manifold kit G2" ½ 2 modules code: 3.032338	Hydraulic manifold kit G2" ½ extension code: 3.033669
2 VICTRIX PRO V2 35-55-60-68-80 EU	N° 1	--
3 VICTRIX PRO V2 35-55-60-68-80 EU	N° 1	N° 1
4 VICTRIX PRO V2 35-55-60-68-80 EU	N° 1	N° 2
5 VICTRIX PRO V2 35-55-60-68-80 EU	N° 1	N° 3

VICTRIX PRO V2 100 - 120 - 150 -180 EU

**17.1 INSTALLATION OF HYDRAULIC MANIFOLD KIT (OPTIONAL)
AT RH/LH IN SET CONFIGURATION VICTRIX PRO V2 100 - 120 - 150 - 180 EU**

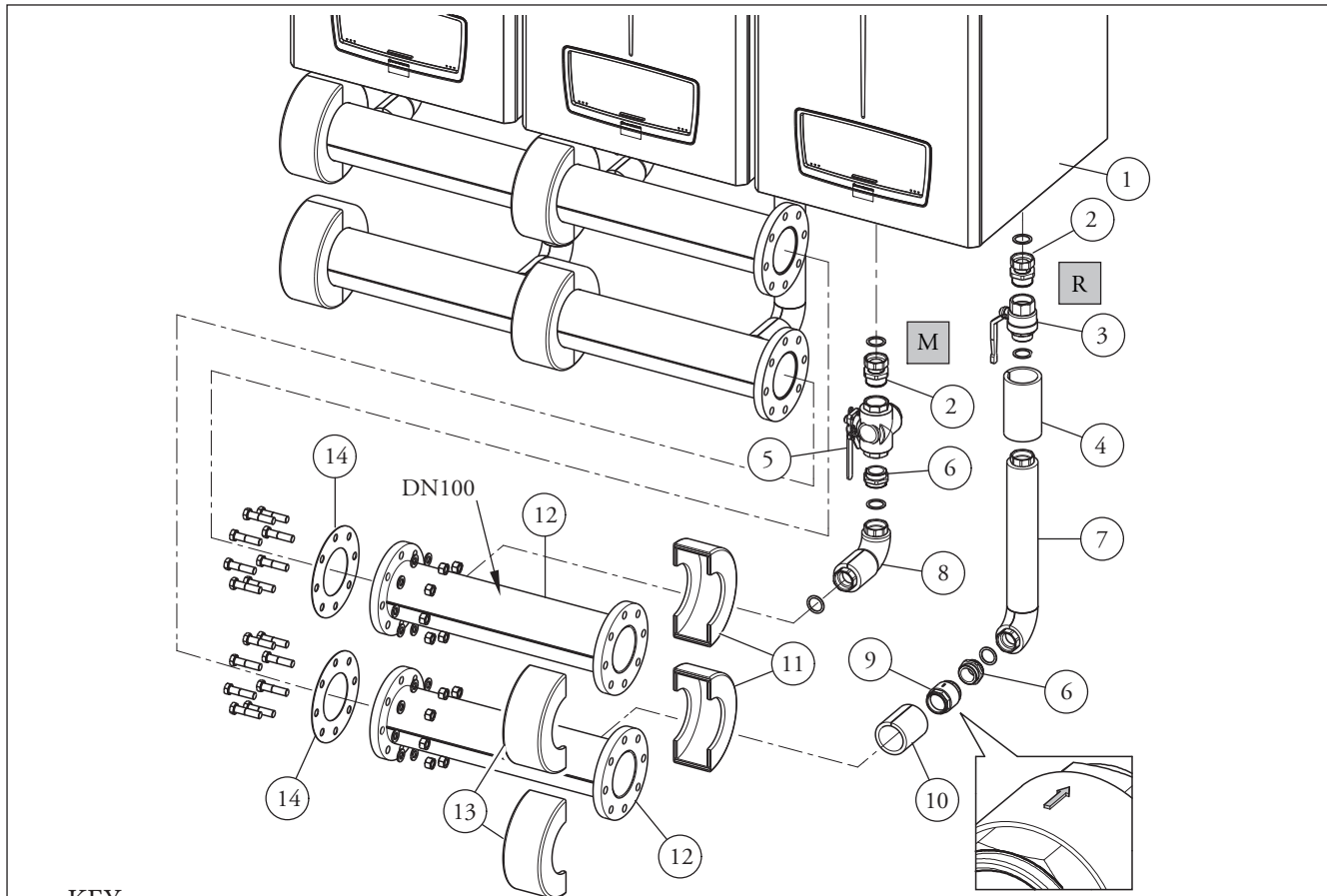

KEY:

- | | |
|--|------------------------------------|
| 1 - Thermal modules in set configuration | 8 - Insulated 90° bend in flow |
| 2 - 2 Valve fixing fittings | 9 - Non return valve |
| 3 - Ball valve | 10 - Insulation |
| 4 - Insulation | 11 - Insulation half-shell |
| 5 - 3-way valve | 12 - 2 Insulated manifolds i DN100 |
| 6 - 2 Nipples | 13 - Insulation half-shell |
| 7 - Long insulated 90° bend in return | 14 - 2 Flange gaskets DN100 |

Modules	Hydraulic manifold kit DN100 2 modules code: 3.033667	Hydraulic manifold kit DN100 extension code: 3.033668
2 VICTRIX PRO V2 100-120-150 EU	N° 1	--
3 VICTRIX PRO V2 100-120-150 EU	N° 1	N° 1
4 VICTRIX PRO V2 100-120-150 EU	N° 1	N° 2
5 VICTRIX PRO V2 100-120-150 EU	N° 1	N° 3
Modules	Hydraulic manifold kit DN100 2 modules code: 3.034938	Hydraulic manifold kit DN100 extension code: 3.034939
2 VICTRIX PRO V2 180 EU	N° 1	--
3 VICTRIX PRO V2 180 EU	N° 1	N° 1
4 VICTRIX PRO V2 180 EU	N° 1	N° 2
5 VICTRIX PRO V2 180 EU	N° 1	N° 3

VICTRIX PRO V2 35 - 55 - 60 - 68 - 80 EU

18

INAIL SAFETY DEVICES KIT G 2 1/2" AT RH/LH FOR VICTRIX PRO V2 35 - 55 - 60 - 68 - 80 EU MODULES IN SET CONFIGURATION (CODE: 3.023955)

The modular boilers, i.e. appliances comprised of multiple modules set up by the manufacturer to operate in cascade (set) with an original Immergas hydraulic manifold kit, must be considered a unique generator, which assumes the serial number (factory number) of the thermal module nearest to the INAIL safety devices. It is therefore possible to flank up to 5 modules, with a unique INAIL safety kit.

With outdoor installation it needs to be protected using the IPX4D protection box kit for set boiler configuration INAIL safety devices, code 3.024038, or nonetheless protected from the elements based on its electrical protection rating.

Immergas S.p.a. declines all liability whenever the installer does not use the devices and INAIL-approved Immergas original kits or uses them improperly.

The sensitive elements of the INAIL safety devices must be set up as described in the installation instructions, in compliance

with the provisions set forth in the "R" collection.

For INAIL design purposes, by installing the Immergas safety Immergas, there are already the following type-approved INAIL devices: Manometer-holder cock, manometer, thermometer, manual reset thermostat, manual reset maximum pressure switch, and manual reset minimum pressure switch (the boiler is already equipped as per standard with 4-bar safety valve and standard draining funnel).

There is a fitting for an expansion vessel on the flow and return stub pipes.

N.B.: The figure illustrates the INAIL safety device kit installation with the outlet on the right side, however, it is also to install the kit with the outlet on the left side.

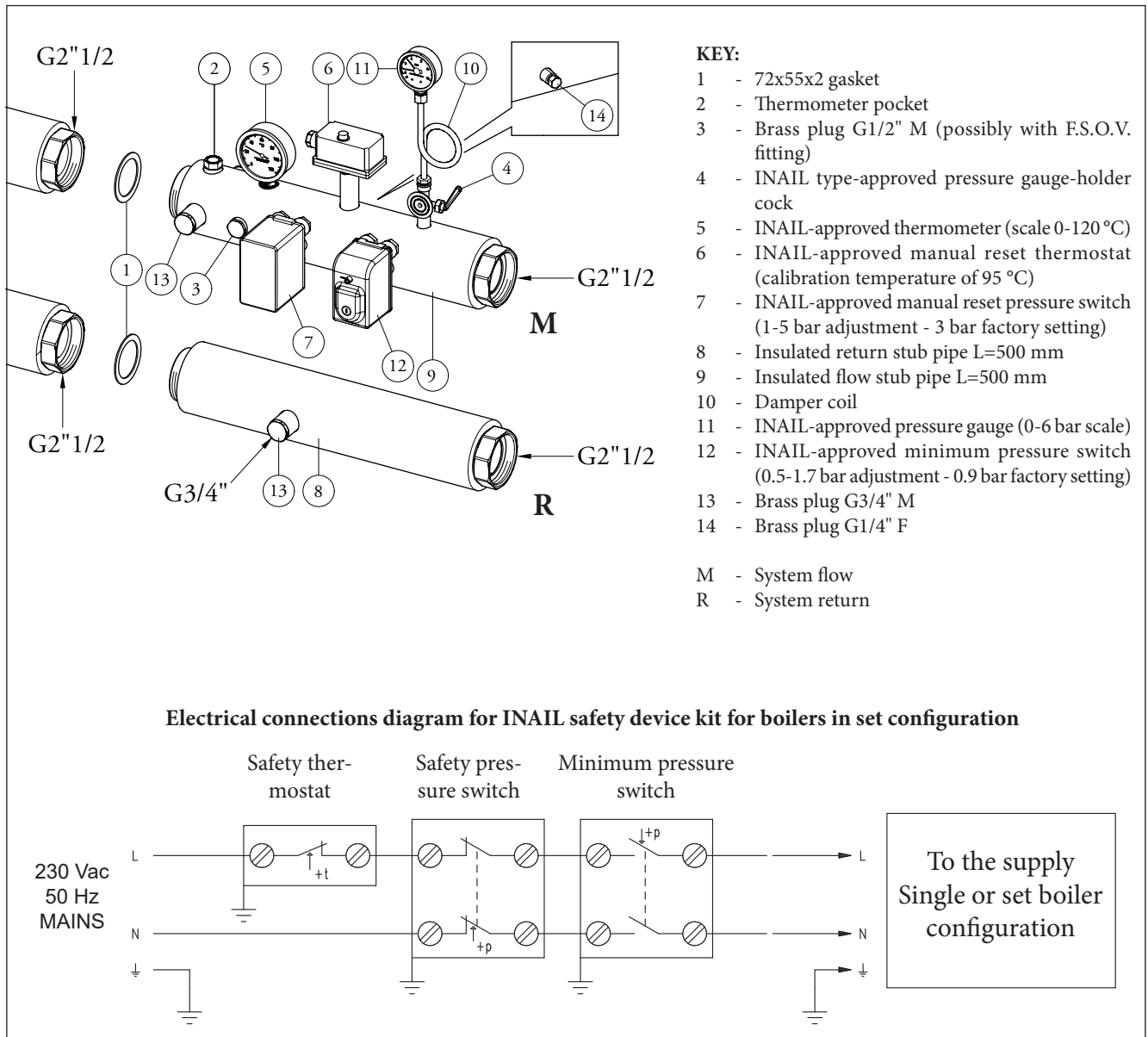

VICTRIX PRO V2 100 - 120 - 150 -180 EU

18.1 INAIL SAFETY DEVICES KIT DN 100 AT RH/LH FOR VICTRIX PRO V2 100 - 120 - 150 - 180 EU MODULES IN SET CONFIGURATION (CODE: 3.023961)

The modular boilers, i.e. appliances comprised of multiple modules set up by the manufacturer to operate in cascade (set) with an original Immergas hydraulic manifold kit, must be considered a unique generator, which assumes the serial number (factory number) of the thermal module nearest to the INAIL safety devices. It is therefore possible to flank up to 5 modules, with a unique INAIL safety kit.

With outdoor installation it needs to be protected using the IPX4D protection box kit for set boiler configuration INAIL safety devices, code 3.024038, or nonetheless protected from the elements based on its electrical protection rating.

Immergas S.p.a. declines all liability whenever the installer does not use the devices and INAIL-approved Immergas original kits or uses them improperly.

The sensitive elements of the INAIL safety devices must be set up as described in the installation instructions, in compliance

with the provisions set forth in the "R" collection.

For INAIL design purposes, by installing the Immergas safety Immergas, there are already the following type-approved INAIL devices: Pressure gauge-holder cock, pressure gauge, thermometer, manual reset thermostat, manual reset maximum pressure switch, and manual reset minimum pressure switch (the boiler is already equipped as per standard with 5,4-bar safety valve and standard draining funnel).

There is a fitting for an expansion vessel on the flow and return stub pipes.

N.B.: The figure illustrates the INAIL safety device kit installation with the outlet on the right side, however, it is also to install the kit with the outlet on the left side.

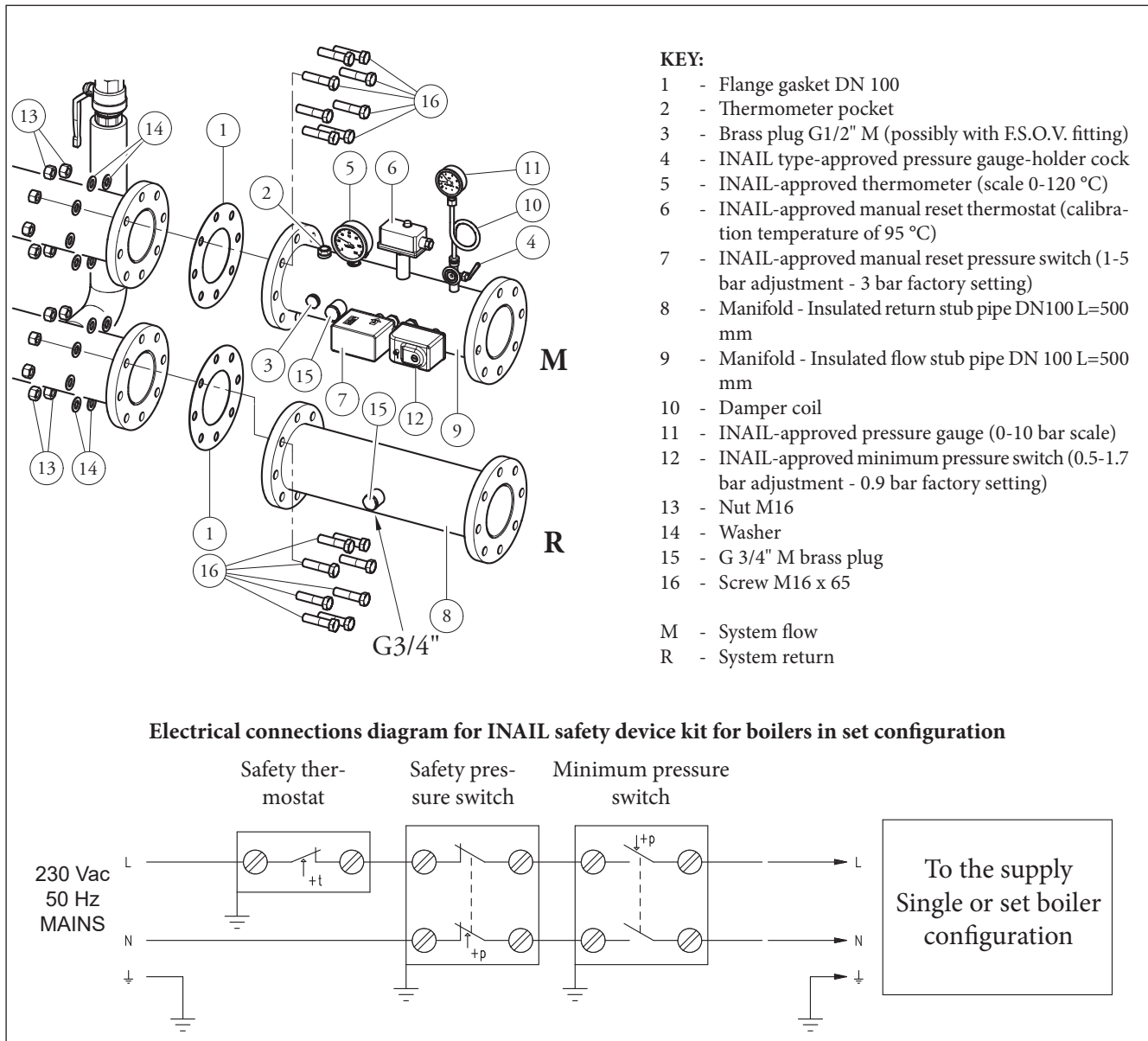

VICTRIX PRO V2 EU

19 HYDRAULIC SEPARATOR KIT FOR MODULES IN SET CONFIGURATION(OPTIONAL)

The hydraulic separator, also called compensator, is an open manifold (1) with puts the flow lines and return lines of 2 or more hydraulic circuits in communication: in this case, a primary circuit (Generator-Manifold) and a secondary circuit (Manifold-Thermal system). Circulation is ensured by the generator in the primary circuit, while there are one or more pumps in the secondary circuit which, based on the system design, provide the correct tem-

perature difference (therefore with the right water flow rate) so as to exchange the output necessary. It is advisable to include a hydraulic compensator (1) every time the overall flow rate required by the system is greater than what the boiler is able to supply. The maximum flow rate at the inlet is the generally adopted sizing method (see the graph below for separator selection).

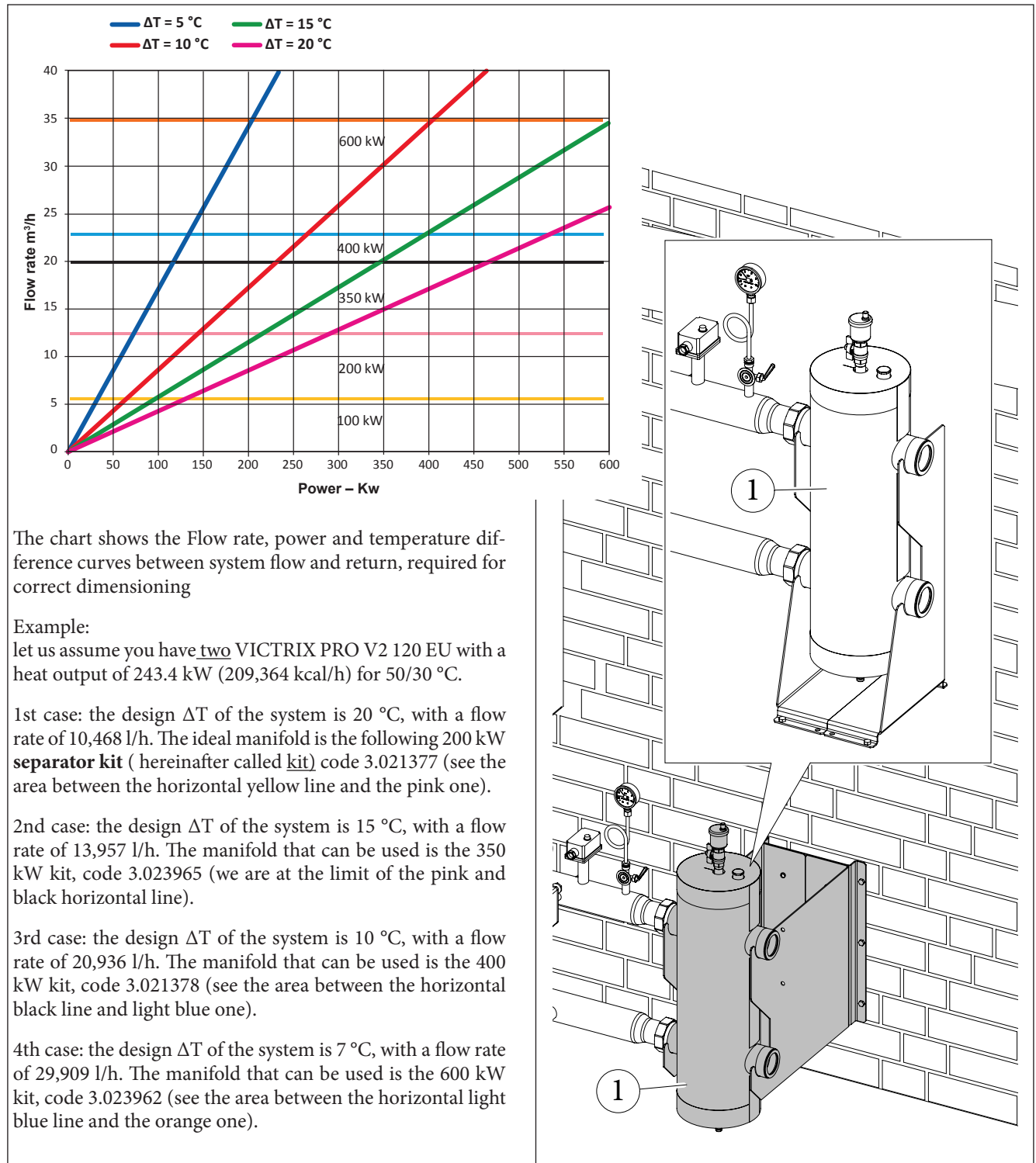

VICTRIX PRO V2 35 - 55 - 60 - 68 - 80 EU

19.1 HYDRAULIC SEPARATOR KIT FOR MODULES UP TO 100 kW G 2 1/2" THREADED CONNECTIONS (CODE: 3.020839)

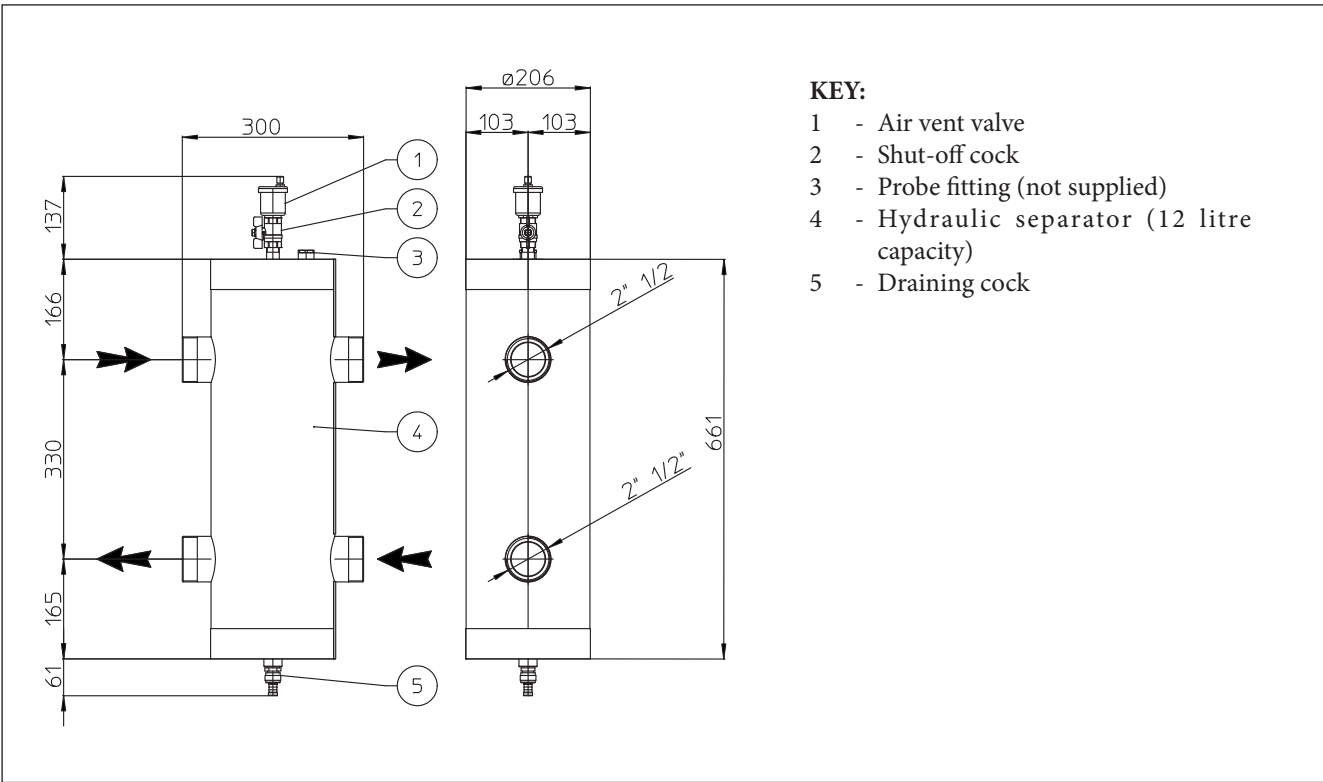

19.2 HYDRAULIC SEPARATOR KIT FOR MODULES IN SET CONFIGURATION UP TO 200 kW G 2 1/2" THREADED CONNECTIONS (CODE: 3.021377)

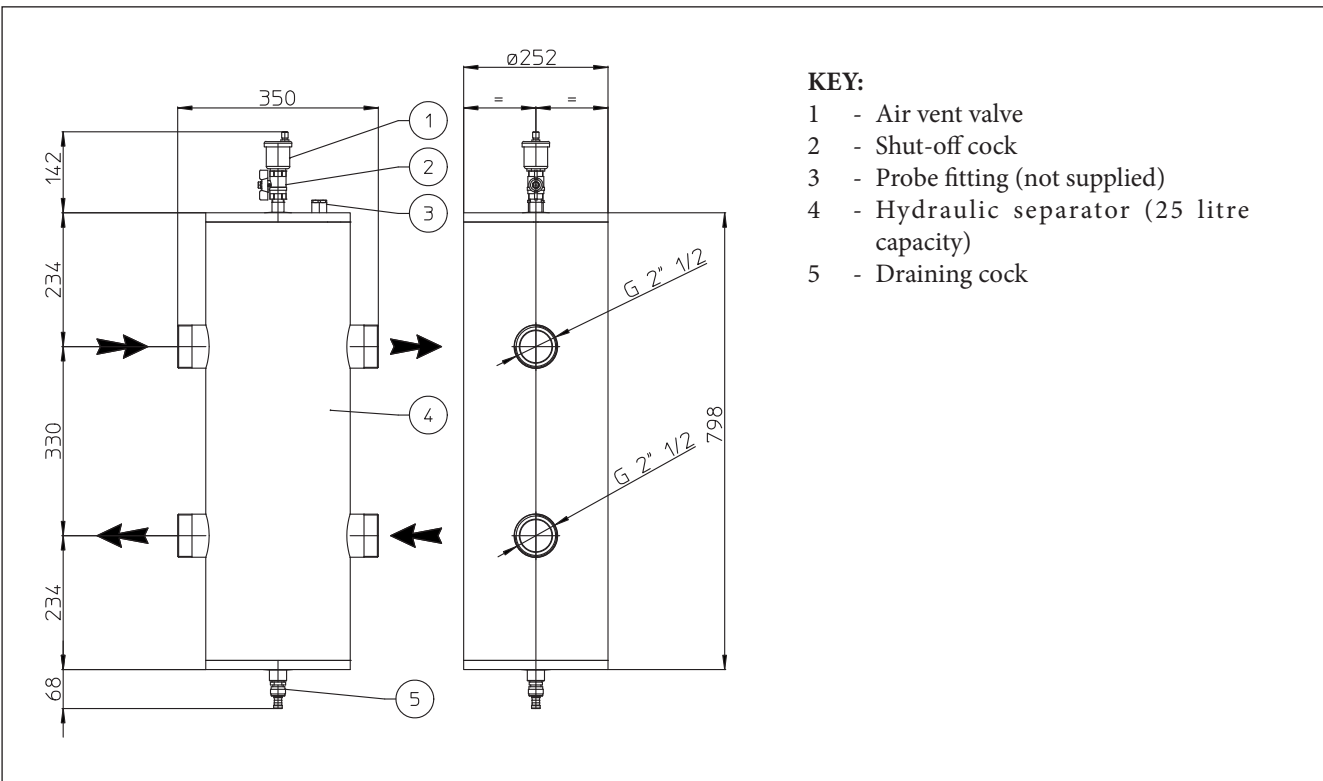

VICTRIX PRO V2 EU

19.3 HYDRAULIC SEPARATOR KIT FOR MODULES IN SET CONFIGURATION UP TO 350 kW FLANGED CONNECTIONS DN 100 (CODE: 3.023965)

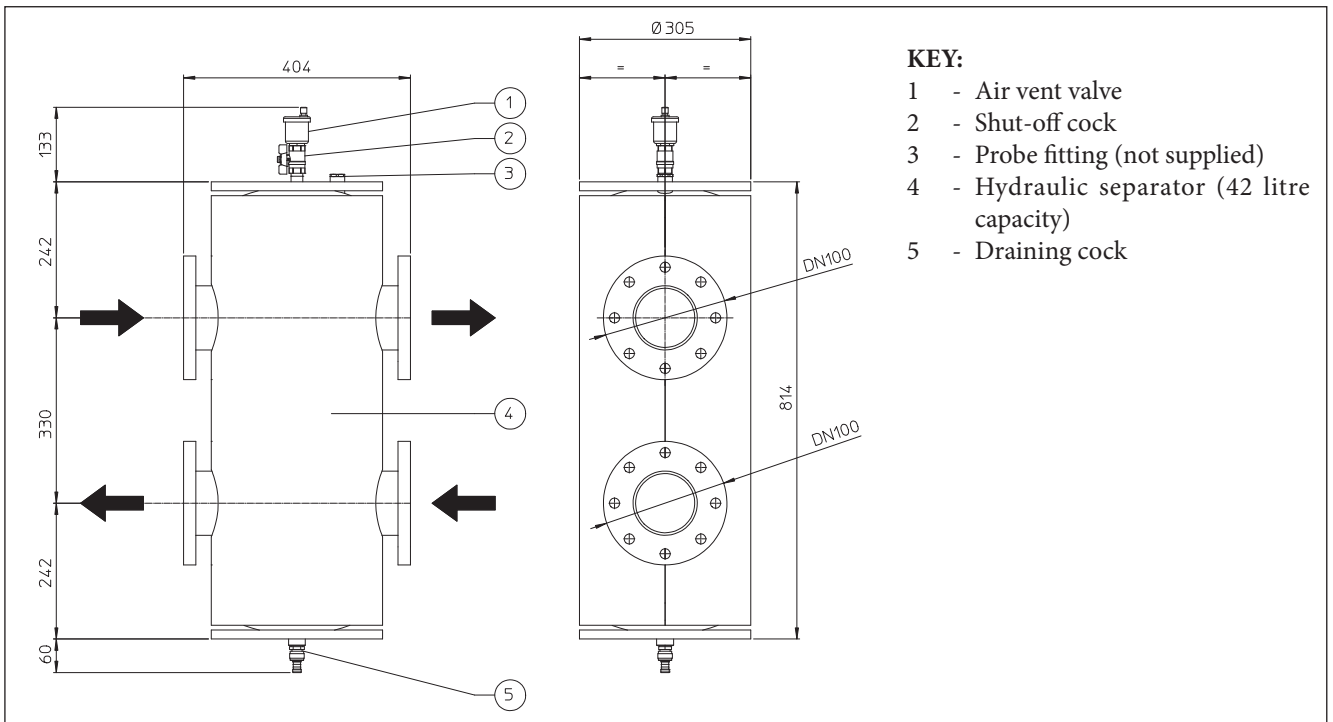

19.4 HYDRAULIC SEPARATOR KIT FOR MODULE IN SET CONFIGURATION UP TO 400 kW G 2 1/2" FLANGED CONNECTIONS - DN 100 (CODE: 3.021378)

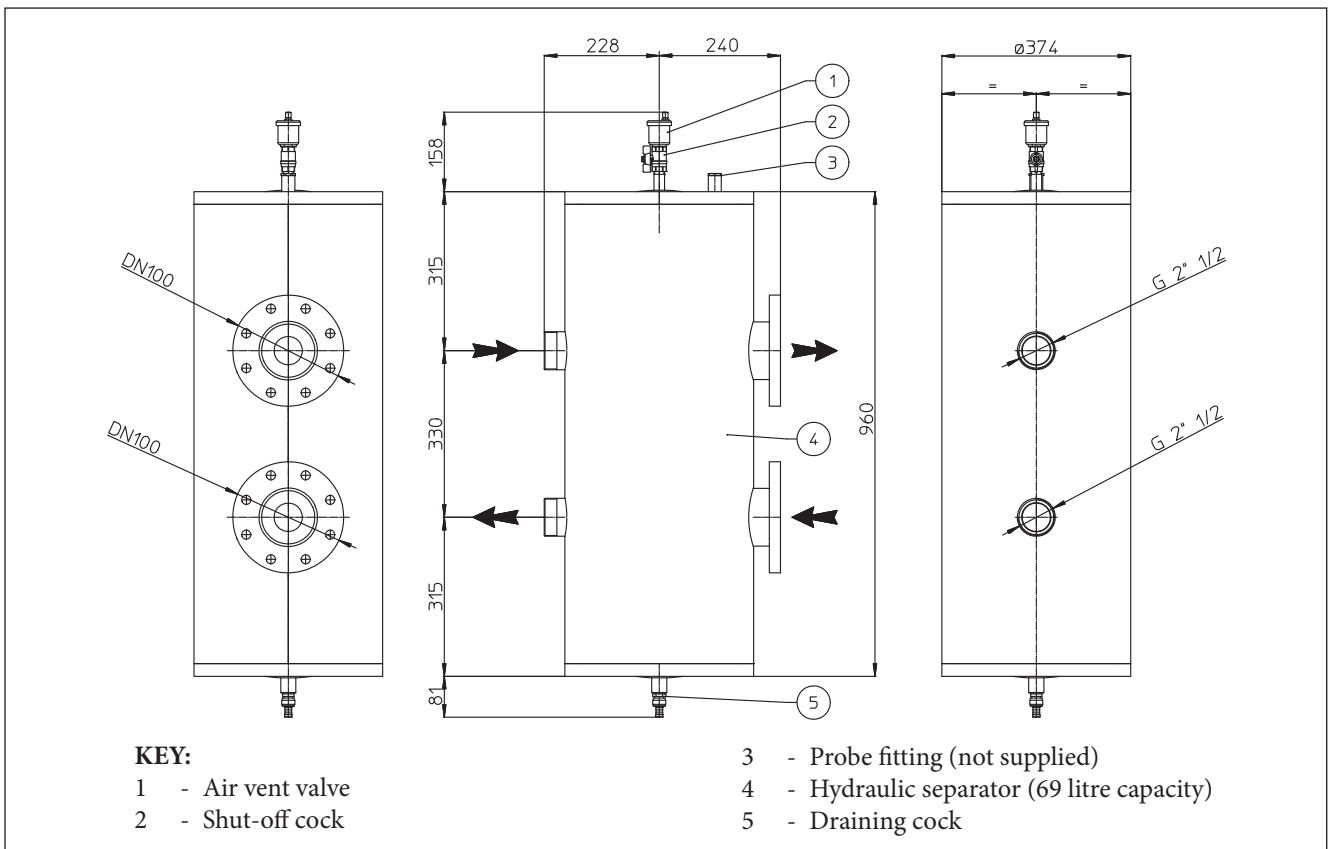

VICTRIX PRO V2 100 - 120 - 150 -180 EU

19.5 HYDRAULIC SEPARATOR KIT FOR MODULES IN SET CONFIGURATION UP TO 600 kW FLANGED CONNECTIONS DN 100 (CODE: 3.023962)

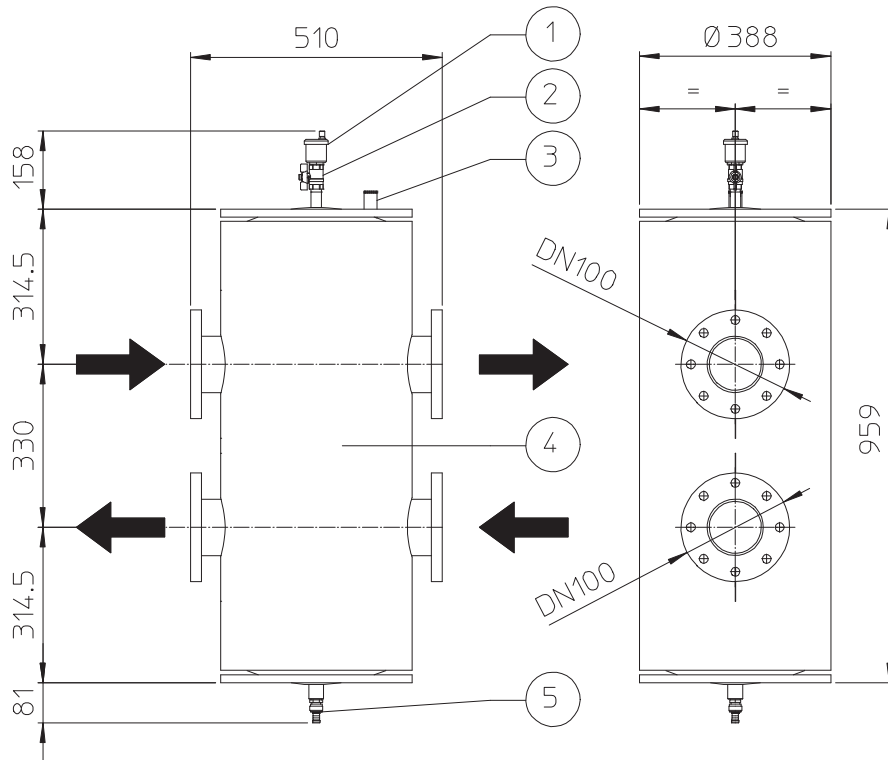

KEY:

- 1 - Air vent valve
- 2 - Shut-off cock
- 3 - Probe fitting (not supplied)
- 4 - Hydraulic separator (85 litre capacity)
- 5 - Draining cock

VICTRIX PRO V2 EU

20 PLATE HEAT CONVEYOR KIT FOR MODULES IN SET CONFIGURATION (OPTIONAL)

Plate heat conveyors are important components of thermal systems and hydraulic circuits.

The components consist of a series of plates appropriately coupled one to the other, which perform fluid separation and thermal exchange between 2 circuits called: Primary and Secondary.

Designed to maximize countercurrent thermal exchange, they are made with 4 connections that put the flow lines in communication with the return lines of each circuit (the primary divided from the secondary).

Circulation is ensured by the generator in the primary circuit,

while there are one or more pumps in the secondary circuit which, based on the system design, provide the correct temperature difference (therefore with the right water flow rate) so as to exchange the output actually necessary.

It is advisable to insert the plate heat exchanger whenever a new generator is installed on an existing system.

This keeps the buildup of filth of the existing system from endangering the efficiency and operation of the new generators.

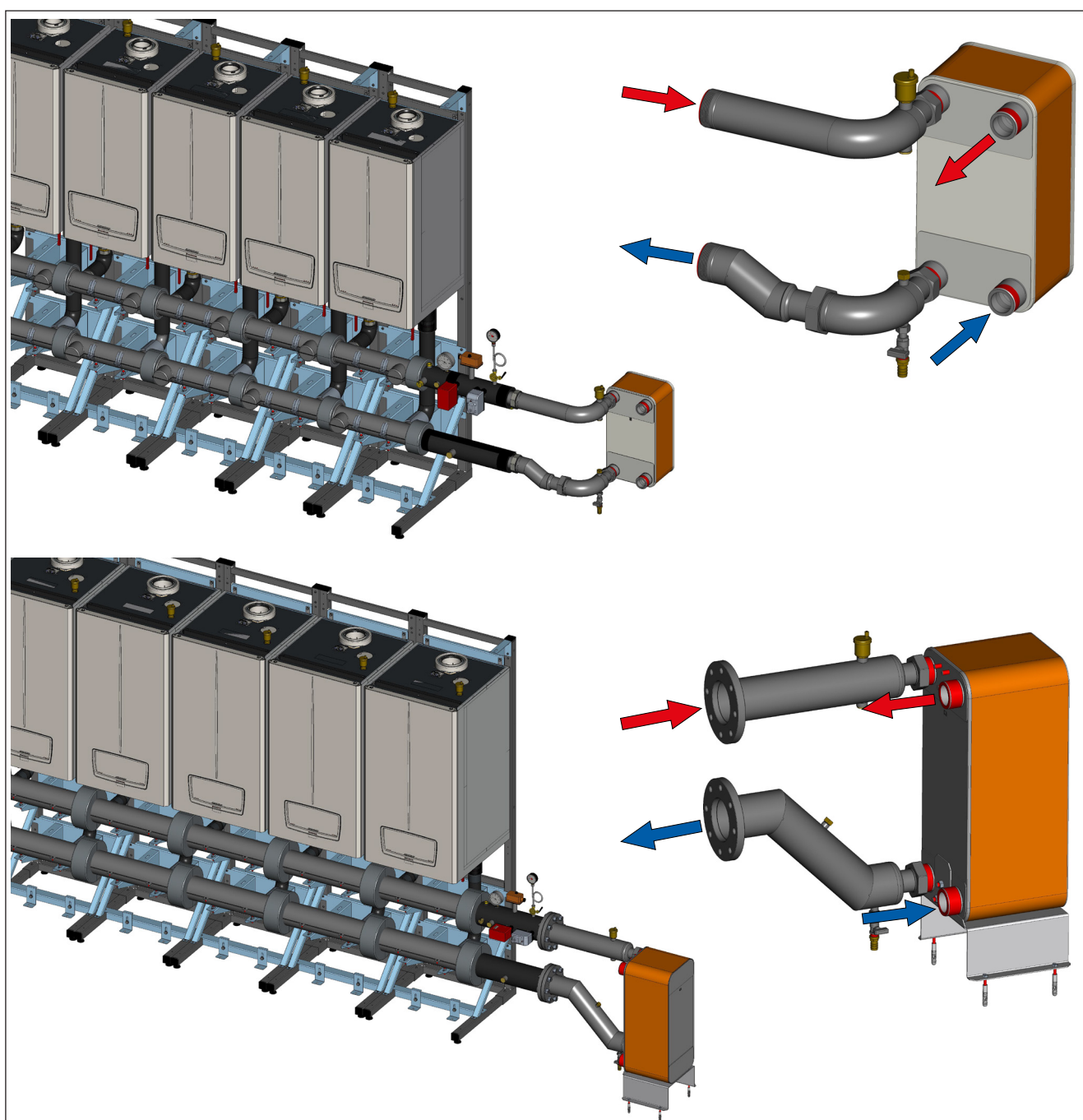

VICTRIX PRO V2 35 - 55 - 60 - 68 - 80 EU

20.1 INSTALLATION OF RH/LH PLATE HEAT EXCHANGER KIT ON VICTRIX PRO V2 35 - 55 - 60 - 68 - 80 EU MODULES IN SET CONFIGURATION (CODE: 3.033678)

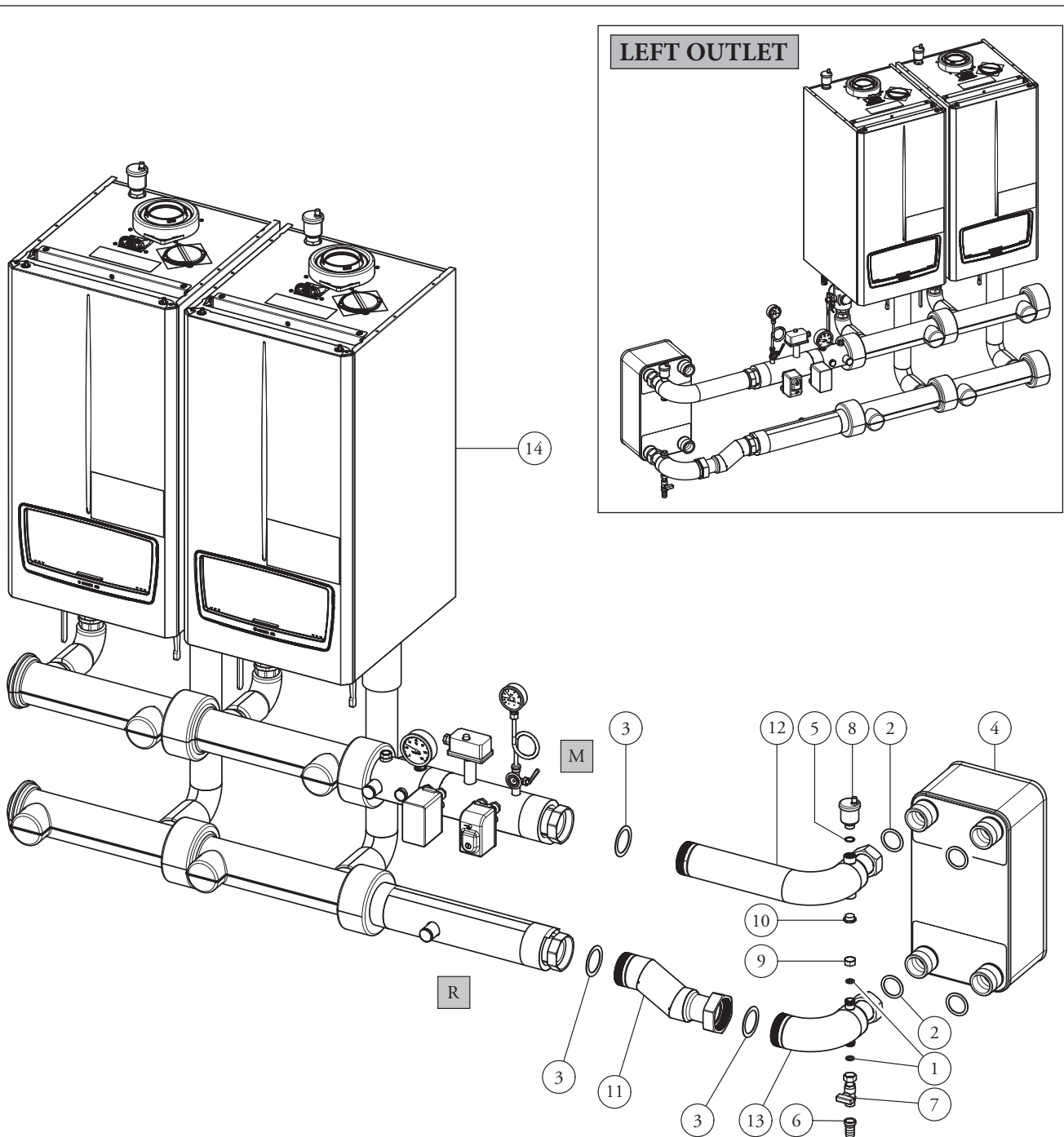

KEY:

- | | |
|---|--------------------------------------|
| 1 - 2 Gaskets 18.5x11.5x2 AFM 34/2 | 8 - Automatic air vent valve ½" mini |
| 2 - 4 Gaskets 56x44x2 AFM 37 | 9 - Cap ½" F hex key 23 mm |
| 3 - 3 Gaskets 75x55x2 mm in Fasit Soft RG | 10 - Brass plug Kramer G½" male |
| 4 - Plate heat exchanger threaded connections Ø 2" | 11 - Pipe DN65 G2" ½ M-F return |
| 5 - O.R. 18X2 Nitrile 70 SH | 12 - Pipe DN65 G2" ½ M G2" F flow |
| 6 - Hose union fitting type Roma fem. G½" X15 | 13 - Pipe DN65 G2" ½ M G2" F return |
| 7 - Cock G½" M-F with bar hold | 14 - Modules in set configuration |

VICTRIX PRO V2 35 - 55 - 60 - 68 - 80 EU

20.2 PLATE HEAT EXCHANGER KIT ON VICTRIX PRO V2 35 - 55 - 60 - 68 - 80 EU MODULES IN SET INSTALLATION TECHNICAL DATA (CODE: 3.033678)

WATER VOLUMES IN KIT COUPLED WITH:

Model	Primary circuit litre content	Expansion vessel capacity (litres)	Max system side heat exchanger pressure (bar)
n° 2 VICTRIX PRO V2 35 EU	25	4	25
n° 3 VICTRIX PRO V2 35 EU	34	4	25
n° 4 VICTRIX PRO V2 35 EU	43	8	25
n° 5 VICTRIX PRO V2 35 EU	52	8	25
n° 2 VICTRIX PRO V2 55 EU	26	4	25
n° 3 VICTRIX PRO V2 55 EU	35	4	25
n° 4 VICTRIX PRO V2 55 EU	45	8	25
n° 5 VICTRIX PRO V2 55 EU	54	8	25
n° 2 VICTRIX PRO V2 60-68-80 EU	27	4	25
n° 3 VICTRIX PRO V2 60-68-80 EU	37	4	25
n° 4 VICTRIX PRO V2 60-68-80 EU	46	8	25
n° 5 VICTRIX PRO V2 60-68-80 EU	56	8	25

TECHNICAL DATA

Plate heat exchanger coupled with VICTRIX PRO V2 EU (kW)	No. plates	Maximum managed power (kW)	Flow rate Primary (m ³ /h) M/R 80°/60°	Flow rate Secondary (m ³ /h) M/R 70°/55°	Δp (m.w.c.)		Weight of heat exchanger only (kg)
					Primary circuit ΔT 20°C	Secondary circuit ΔT 15°C	
175	90	400	7.6	10.0	0.23	0.4	31.3
200			8.6	11.5	0.3	0.52	
250			10.7	14.3	0.46	0.82	
275			11.8	15.7	0.6	0.99	
300			12.9	17.2	0.67	1.18	
350			15.0	20.0	0.9	1.6	
400			17.2	22.9	1.2	2.1	

Plate heat exchanger coupled with VICTRIX PRO V2 EU (kW)	No. plates	Maximum managed power (kW)	Flow rate Primary (m ³ /h) M/R 80°/65°	Flow rate Secondary (m ³ /h) M/R 70°/60°	Δp (m.w.c.)		Weight of heat exchanger only (kg)
					Primary circuit ΔT 15°C	Secondary circuit ΔT 10°C	
175	90	400	10.0	15.0	0.41	0.94	31.3
200			11.5	17.2	0.53	1.23	
250			14.3	21.5	0.83	1.91	
275			15.7	23.6	1.0	2.32	
300			17.2	25.8	1.2	2.76	
350			20.0	30.0	1.63	3.75	
400			22.9	34.4	2.25	4.9	

VICTRIX PRO V2 100 - 120 - 150 -180 EU

20.3 INSTALLATION OF RH/LH PLATE HEAT EXCHANGER KIT ON VICTRIX PRO V2 100 - 120 - 150 - 180 EU MODULES IN SET CONFIGURATION (CODE: 3.033679)

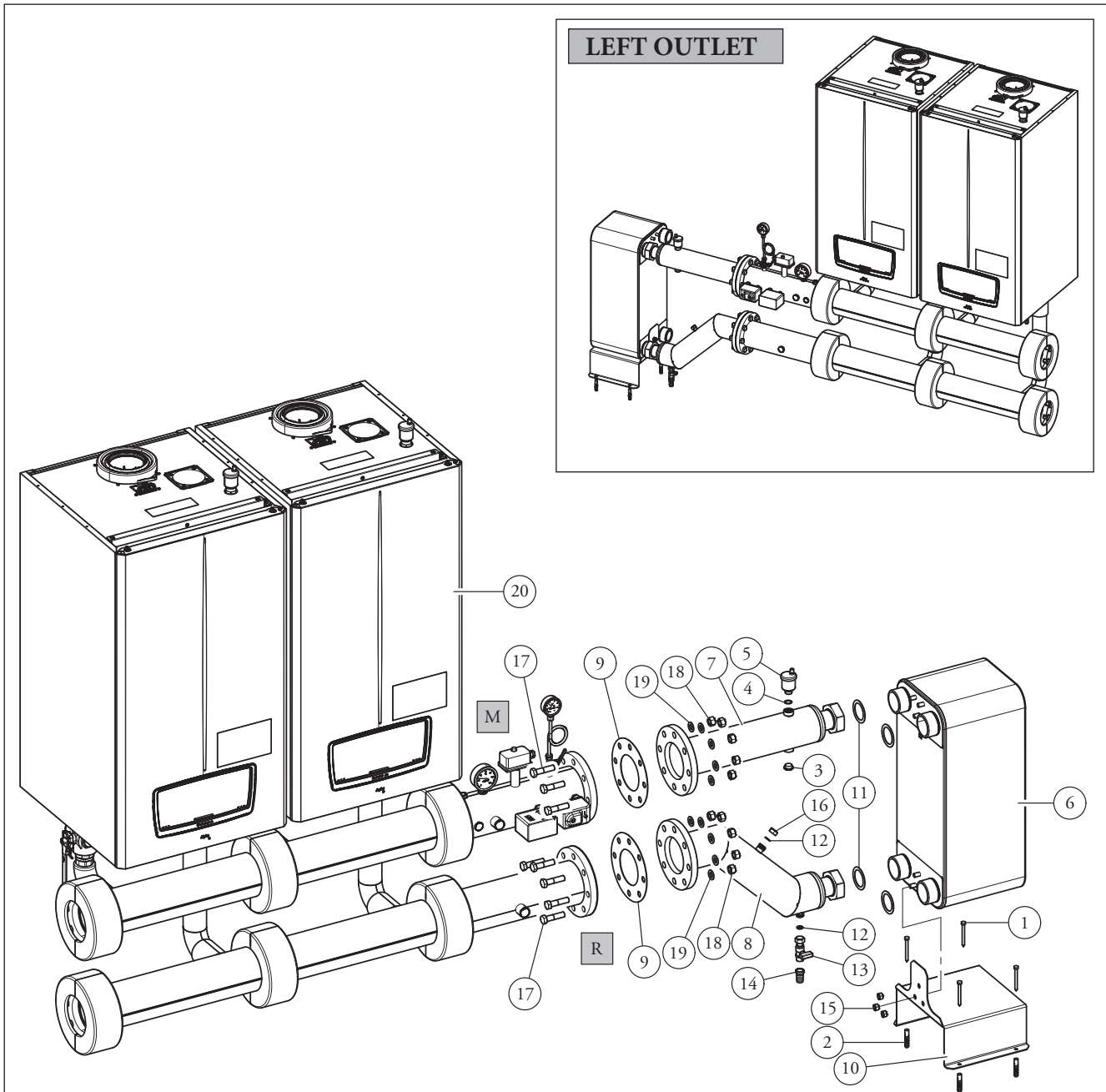

KEY:

- | | |
|---|--|
| 1 - 4 HH screws 8x80 | 10 - Heat exchanger supporting bracket |
| 2 - 4 Plugs 12x60 | 11 - 4 Gaskets 75x55x2 mm in Fasis Soft RG |
| 3 - Brass plug Kramer G $\frac{1}{2}$ " male | 12 - 2 Gaskets 18.5x11.5x2 AFM 34/2 |
| 4 - O.R. 18x2 Nitrile 70 SH | 13 - Cock G $\frac{1}{2}$ " M-F with bar hold |
| 5 - Automatic air vent valve $\frac{1}{2}$ " mini | 14 - Hose union fitting type Roma fem. G $\frac{1}{2}$ " X15 |
| 6 - 100 Plate heat exchanger threaded connections \varnothing 2" $\frac{1}{2}$ | 15 - 3 Nuts M12 |
| 7 - Flow manifold | 16 - Cap $\frac{1}{2}$ " F hex key 23 mm |
| 8 - Return manifold | 17 - 16 HH screws M16x65 |
| 9 - 2 Gaskets | 18 - 16 Hex nuts M16 |
| | 19 - 16 Washers 17x30x3 |
| | 20 - Modules in set configuration |

VICTRIX PRO V2 100 - 120 - 150 - 180 EU

20.4 PLATE HEAT EXCHANGER KIT ON VICTRIX PRO V2 100 - 120 - 150 - 180 EU MODULES IN SET INSTALLATION TECHNICAL DATA (CODE: 3.033679)

WATER VOLUMES IN KIT COUPLED WITH:

Model	Primary circuit litre content	Expansion vessel capacity (litres)	Max system side heat exchanger pressure (bar)
n° 2 VICTRIX PRO V2 100 EU	75	8	16
n° 3 VICTRIX PRO V2 100 EU	100	8	16
n° 4 VICTRIX PRO V2 100 EU	125	12	16
n° 5 VICTRIX PRO V2 100 EU	150	12	16
n° 2 VICTRIX PRO V2 120 EU	77	8	16
n° 3 VICTRIX PRO V2 120 EU	103	8	16
n° 4 VICTRIX PRO V2 120 EU	129	12	16
n° 5 VICTRIX PRO V2 120 EU	155	12	16
n° 2 VICTRIX PRO V2 150 EU	81	8	16
n° 3 VICTRIX PRO V2 150 EU	109	12	16
n° 4 VICTRIX PRO V2 150 EU	137	12	16
n° 5 VICTRIX PRO V2 150 EU	165	18	16
n° 2 VICTRIX PRO V2 180 EU	89	8	16
n° 3 VICTRIX PRO V2 180 EU	121	12	16
n° 4 VICTRIX PRO V2 180 EU	153	12	16
n° 5 VICTRIX PRO V2 180 EU	185	18	16

TECHNICAL DATA

Plate heat exchanger coupled with VICTRIX PRO V2 EU (kW)	No. plates	Maximum managed power (kW)	Flow rate Primary (m ³ /h) M/R 80°/60°	Flow rate Secondary (m ³ /h) M/R 70°/55°	Δp (m.w.c.)		Weight of heat exchanger only (kg)
					Primary circuit ΔT 20°C	Secondary circuit ΔT 15°C	
400	100	850	17.2	22.9	0.27	0.5	65
450			19.3	25.8	0.35	0.64	
500			21.4	28.7	0.43	0.79	
550			23.6	31.5	0.5	0.96	
600			25.8	34.4	0.62	1.14	
650			27.9	37.2	0.73	1.34	
700			30.0	40.1	0.84	1.56	
750			32.2	43.0	0.97	1.79	
800			34.4	45.8	1.10	2.03	
850			36.5	48.7	1.25	2.30	

VICTRIX PRO V2 100 - 120 - 150 -180 EU

TECHNICAL DATA

Plate heat exchanger coupled with VICTRIX PRO V2 EU (kW)	No. plates	Maximum managed power (kW)	Flow rate Primary (m ³ /h) M/R 80°/65°	Flow rate Secondary (m ³ /h) M/R 70°/60°	Δp (m.w.c.)		Weight of heat exchanger only (kg)
					Primary circuit ΔT 15°C	Secondary circuit ΔT 10°C	
400	100	850	22.9	34.4	0.53	1.15	65
450			25.8	38.7	0.67	1.45	
500			28.7	43.0	0.83	1.79	
550			31.5	47.3	1.0	2.17	
600			34.4	51.6	1.2	2.58	
650			37.2	55.9	1.63	3.03	
700			40.1	60.2	2.25	3.51	
750			43.0	64.5	1.87	4.03	
800			45.8	68.8	2.13	4.58	
850			48.7	73.1	2.40	5.18	

VICTRIX PRO V2 35 - 55 - 60 - 68 - 80 EU

20.5 DIMENSIONS AND CONNECTIONS WITH RH/LH PLATE HEAT EXCHANGER KIT FOR VICTRIX PRO V2 35 - 55 - 60 - 68 - 80 EU IN SET INSTALLATION (CODE: 3.033678)

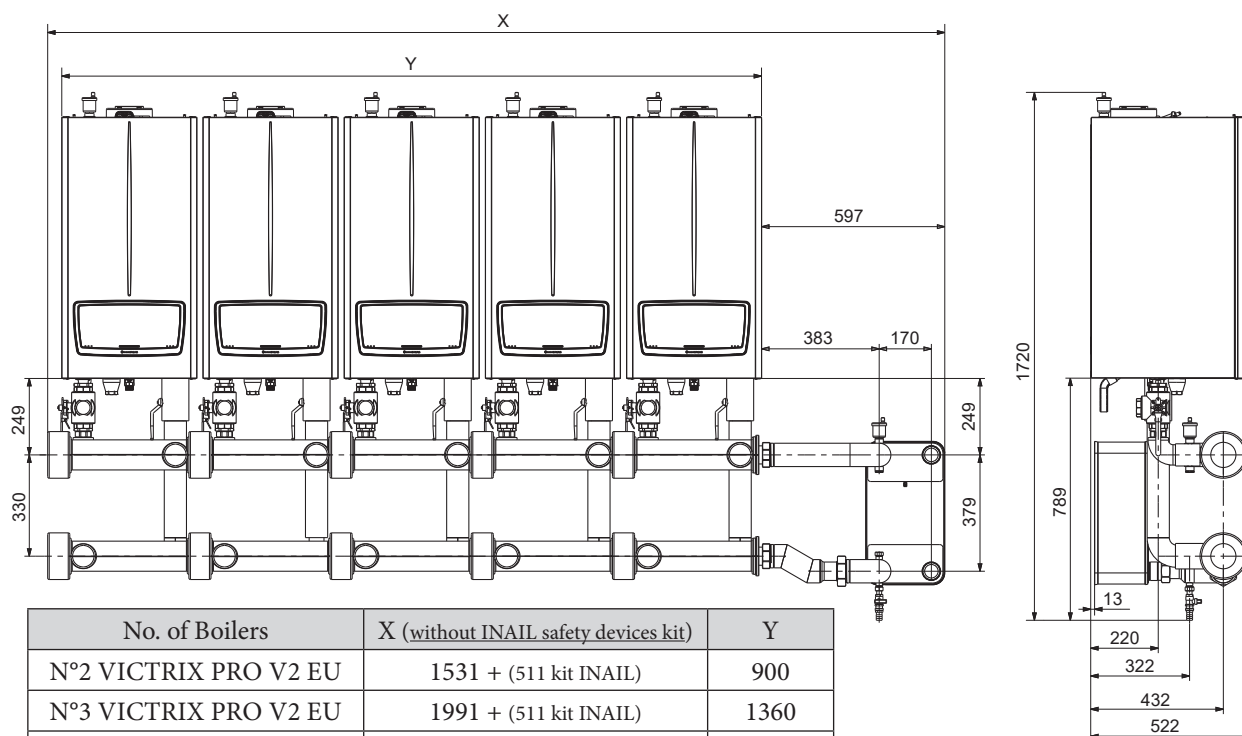

No. of Boilers	X (without INAIL safety devices kit)	Y
N°2 VICTRIX PRO V2 EU	1531 + (511 kit INAIL)	900
N°3 VICTRIX PRO V2 EU	1991 + (511 kit INAIL)	1360
N°4 VICTRIX PRO V2 EU	2451 + (511 kit INAIL)	1820
N°5 VICTRIX PRO V2 EU	2911 + (511 kit INAIL)	2280

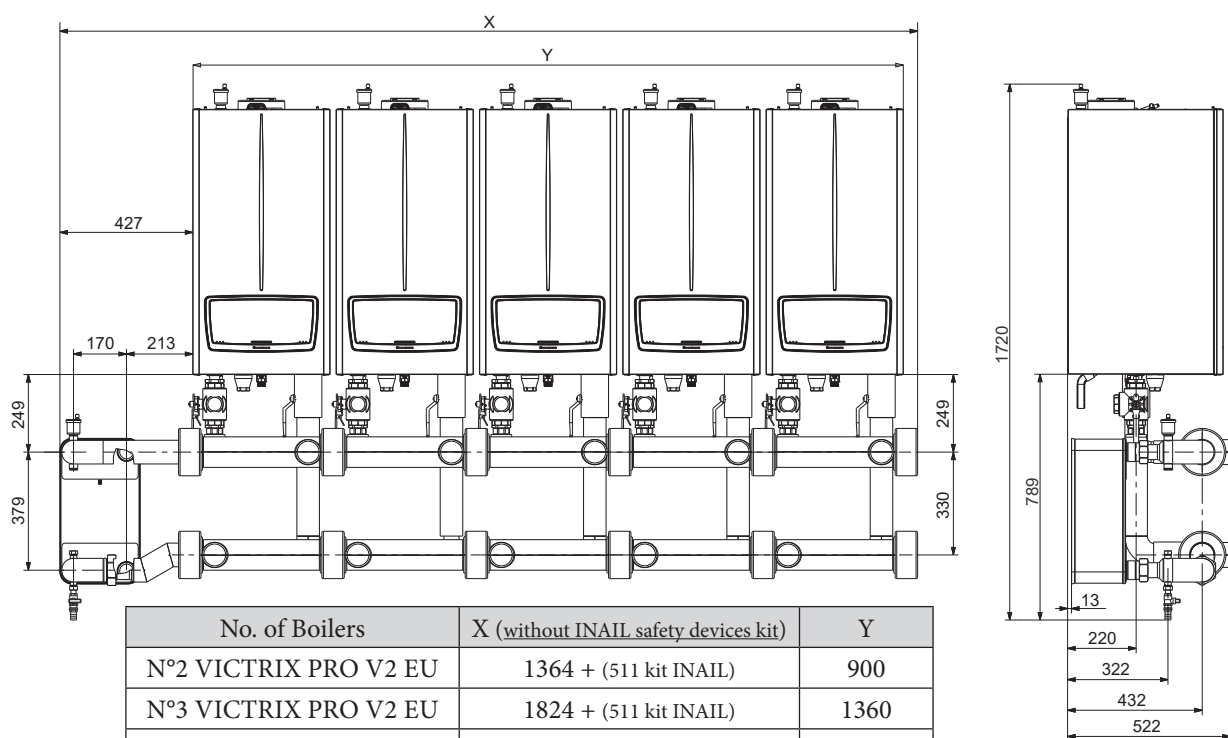

No. of Boilers	X (without INAIL safety devices kit)	Y
N°2 VICTRIX PRO V2 EU	1364 + (511 kit INAIL)	900
N°3 VICTRIX PRO V2 EU	1824 + (511 kit INAIL)	1360
N°4 VICTRIX PRO V2 EU	2284 + (511 kit INAIL)	1820
N°5 VICTRIX PRO V2 EU	2744 + (511 kit INAIL)	2280

VICTRIX PRO V2 100 - 120 - 150 EU

20.6 DIMENSIONS AND CONNECTIONS WITH RH/LH PLATE HEAT EXCHANGER KIT FOR VICTRIX PRO V2 100 - 120 - 150 EU IN SET INSTALLATION (CODE: 3.033679)

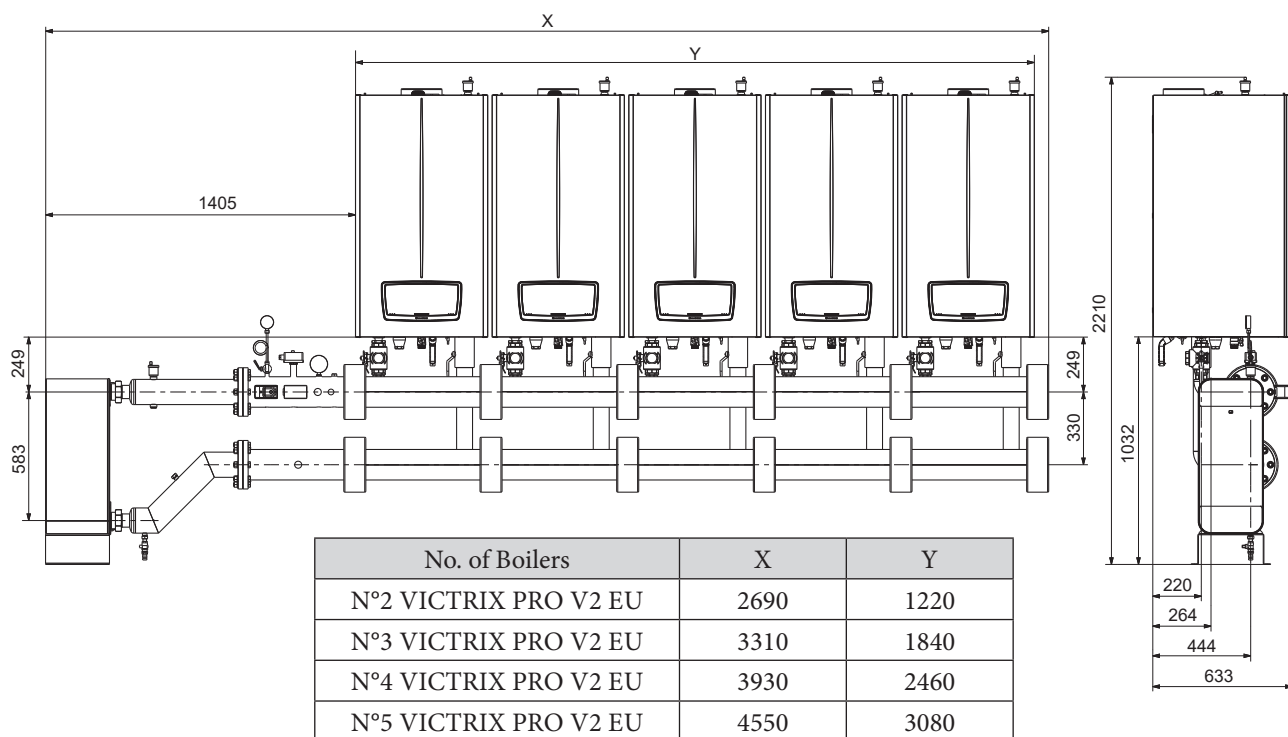
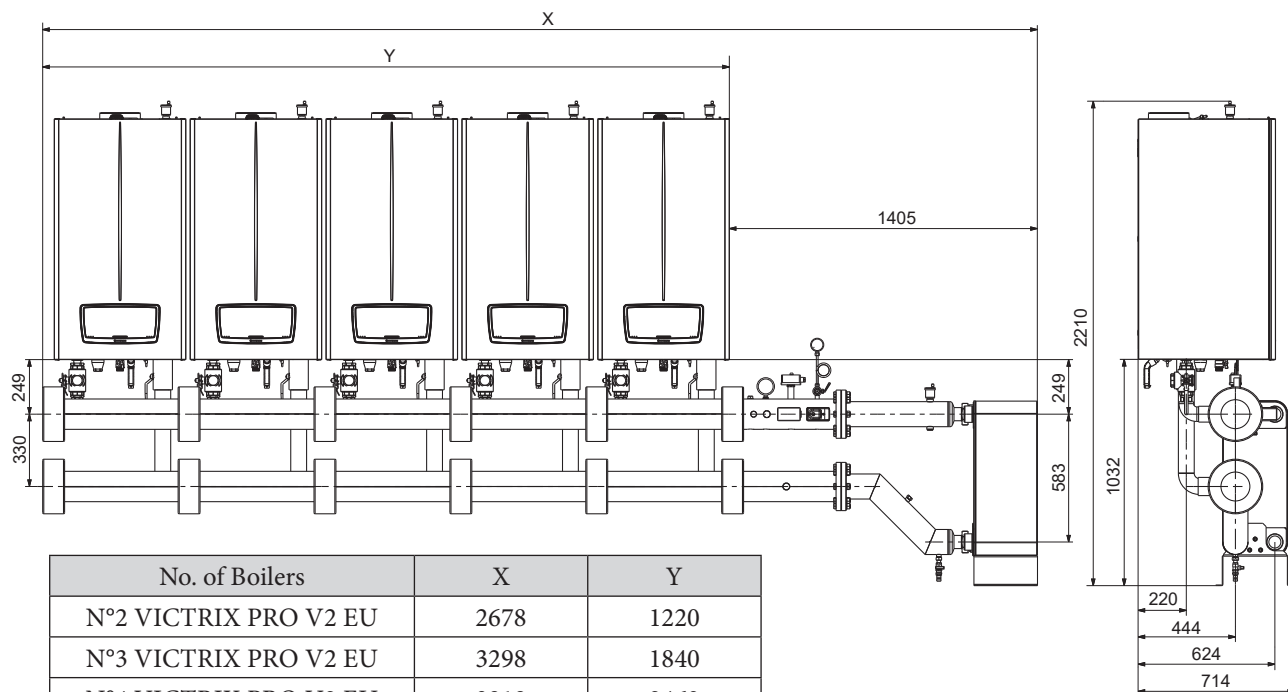

VICTRIX PRO V2 180 EU

20.7 DIMENSIONS AND CONNECTIONS WITH RH/LH PLATE HEAT EXCHANGER KIT FOR VICTRIX PRO V2 180 EU IN SET INSTALLATION (CODE: 3.033679)

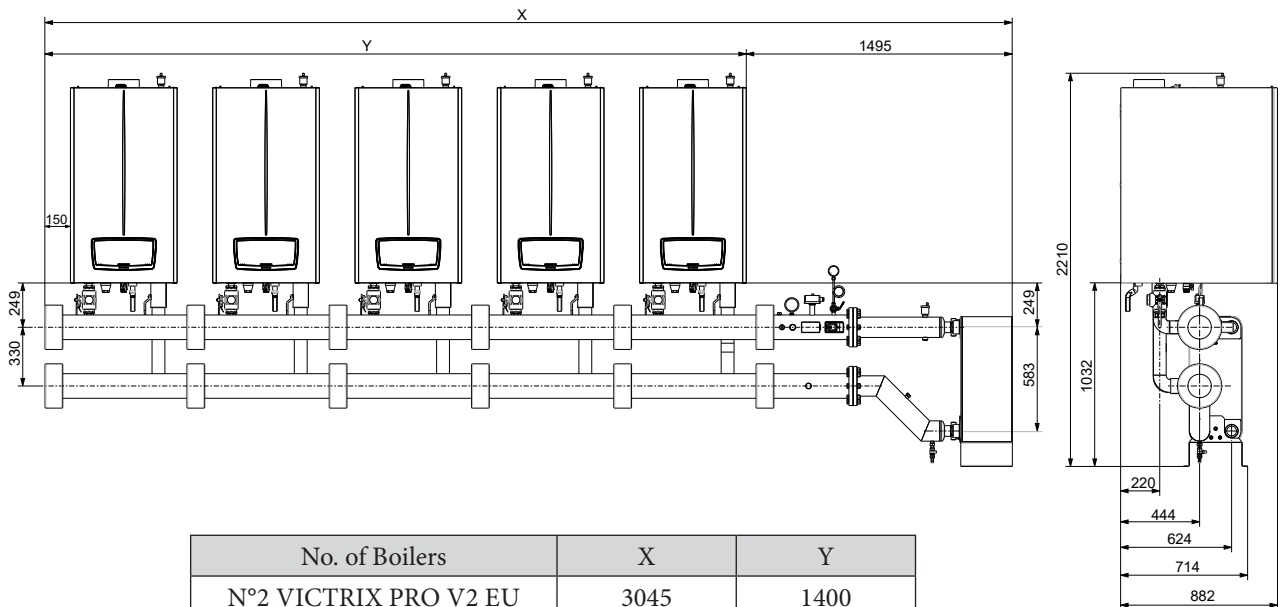

No. of Boilers	X	Y
N°2 VICTRIX PRO V2 EU	3045	1400
N°3 VICTRIX PRO V2 EU	3845	2200
N°4 VICTRIX PRO V2 EU	4645	3000
N°5 VICTRIX PRO V2 EU	5445	3800

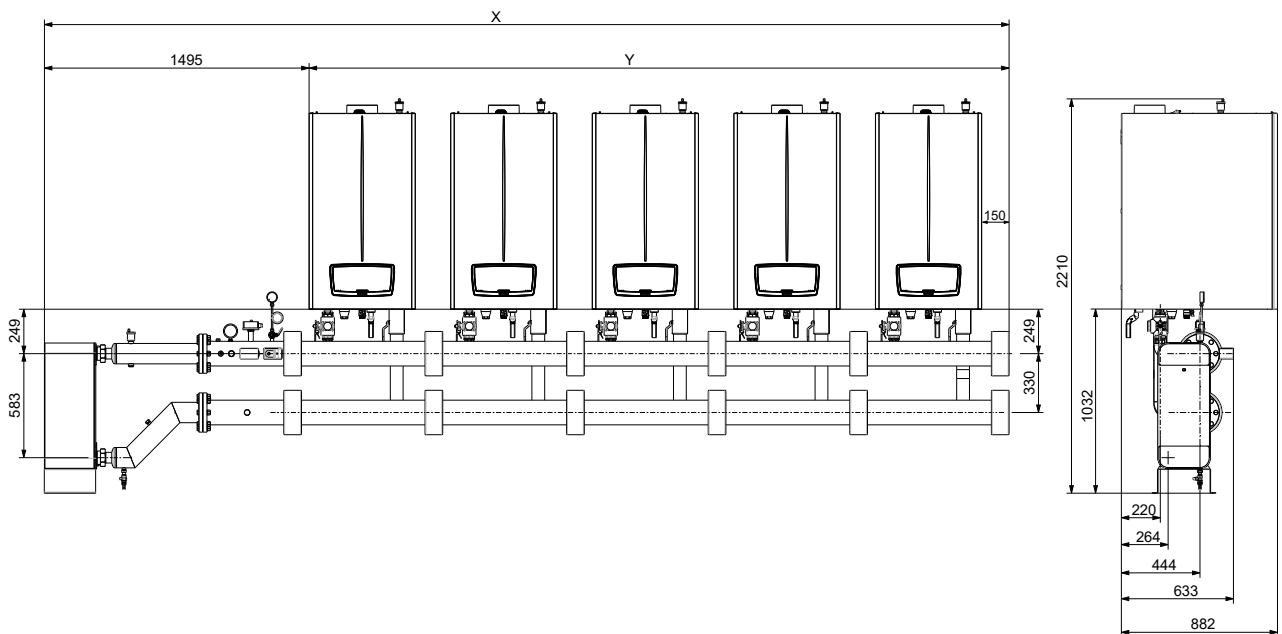

21 SLUDGE REMOVER KIT FOR MODULES IN SET CONFIGURATION (OPTIONAL)

Among the wide range of optionals for new VICTRIX PRO V2 EU generators, Immergas also offers sludge remover kits. Designed to capture the filth inside the systems as much as possible, they help to keep the generator and thermal system efficient.

It is advisable to insert the sludge remover kit whenever a new generator is installed in an existing system, so as to prevent buildups from jeopardising thermal exchange and operation of the new generators.

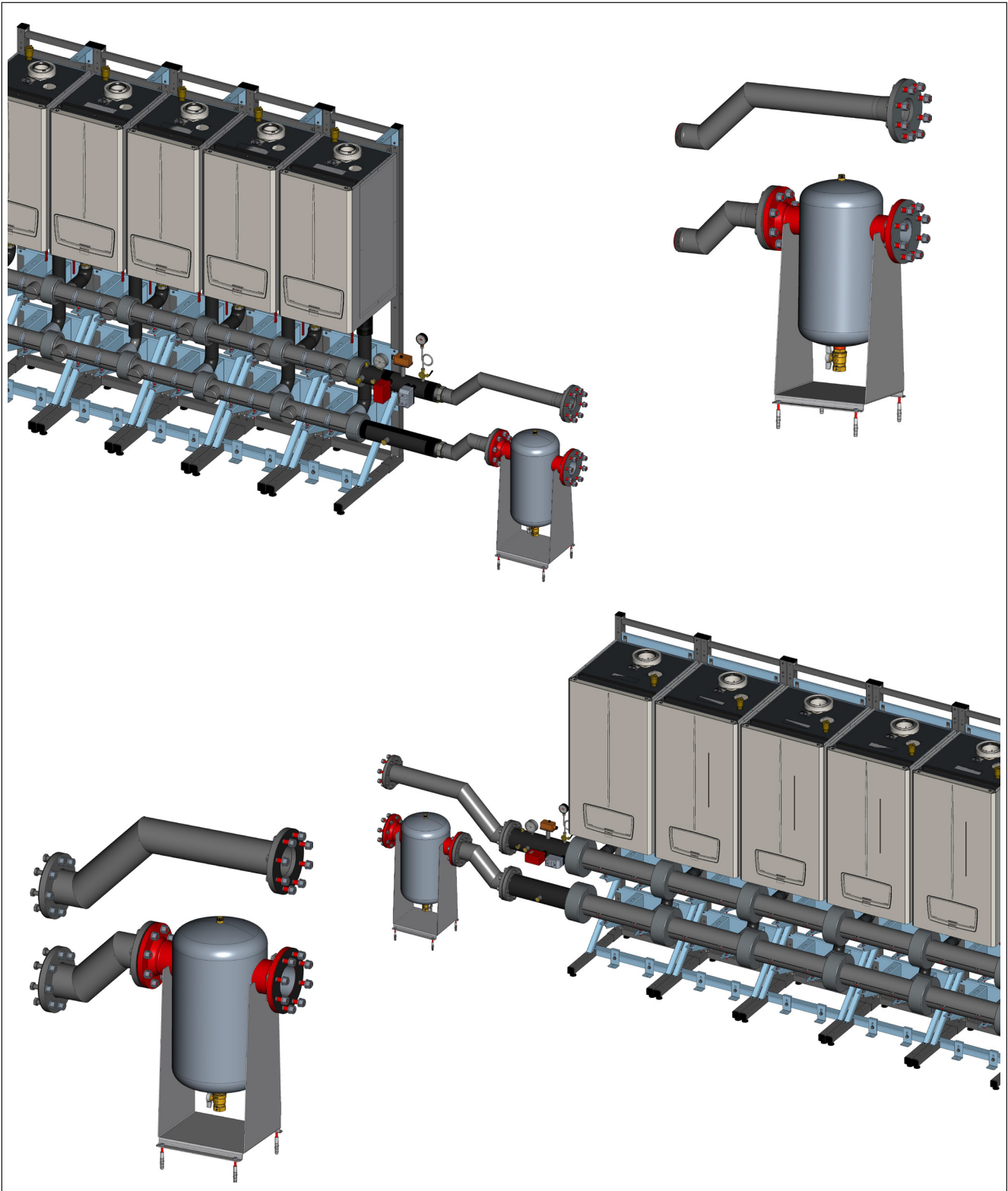

VICTRIX PRO V2 35 - 55 - 60 - 68 - 80 EU

21.1 INSTALLATION OF RH/LH SLUDGE REMOVER KIT ON VICTRIX PRO V2 35 - 55 - 60 - 68 - 80 EU MODULES IN SET CONFIGURATION (CODE: 3.033674)

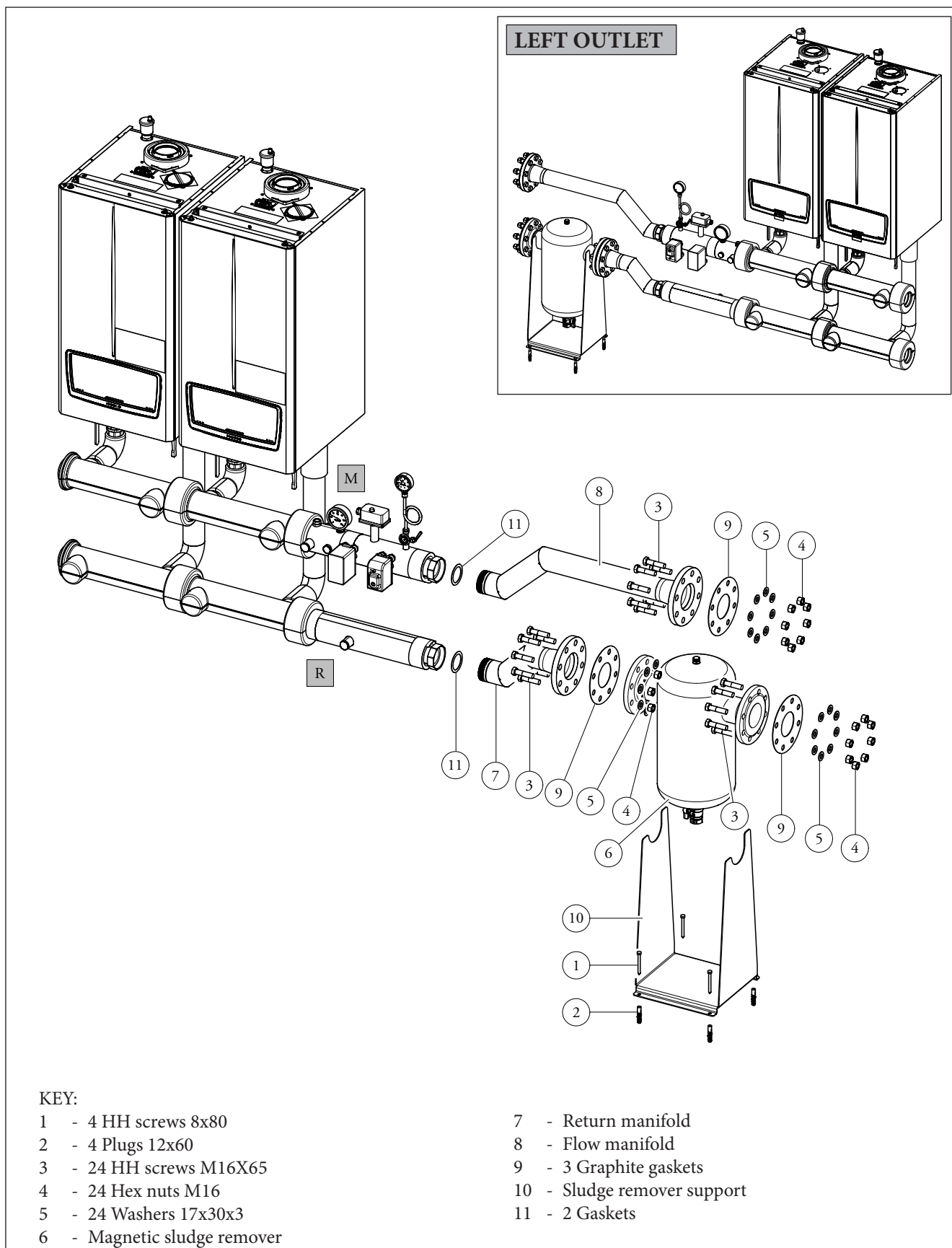

VICTRIX PRO V2 100 - 120 - 150 -180 EU

21.2 INSTALLATION OF RH/LH SLUDGE REMOVER KIT ON VICTRIX PRO V2 100 - 120 - 150 - 180 EU MODULES IN SET CONFIGURATION (CODE: 3.033675)

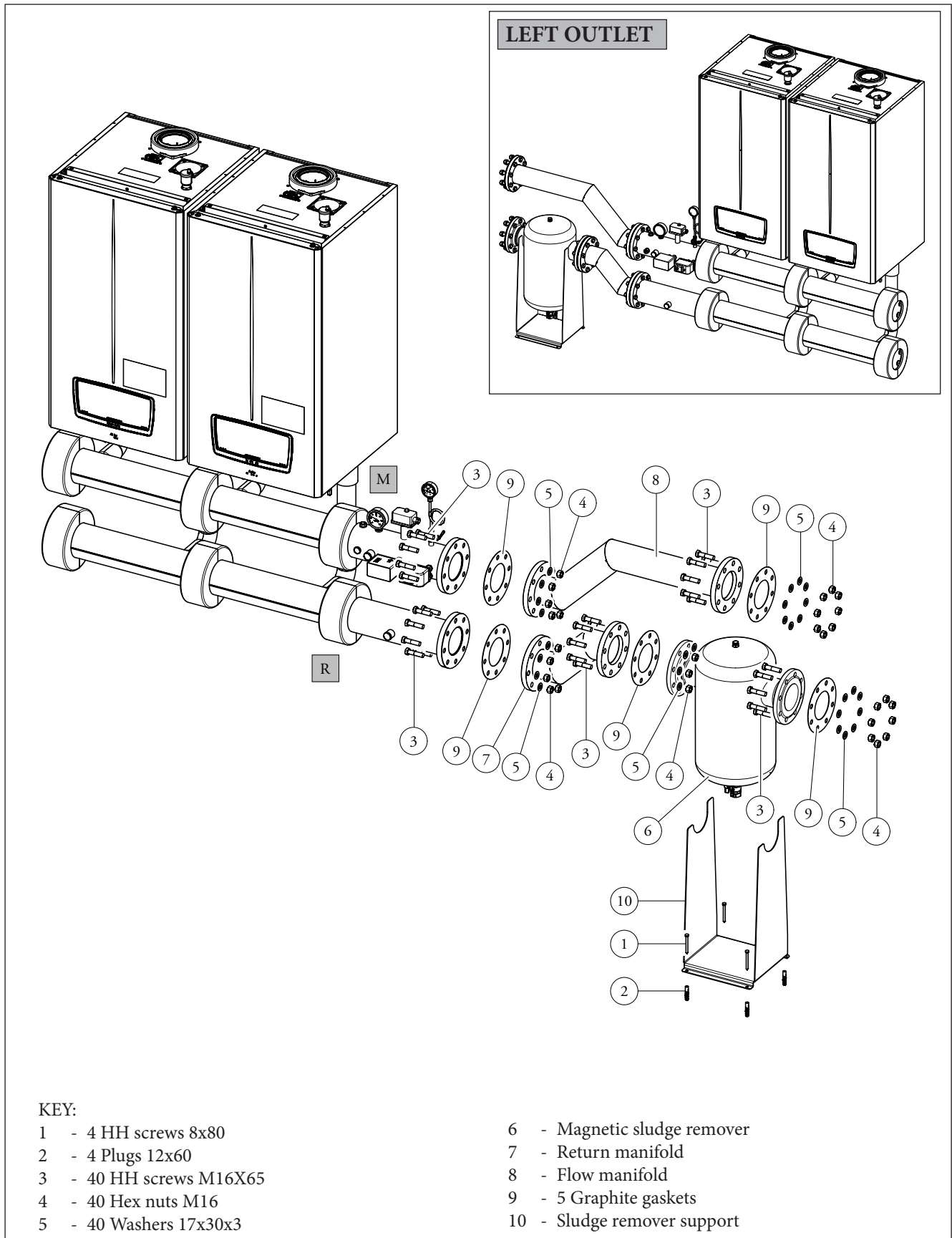

VICTRIX PRO V2 35 - 55 - 60 - 68 - 80 EU

21.3 DIMENSIONS AND CONNECTIONS WITH RH/LH SLUDGE REMOVER KIT FOR VICTRIX PRO V2 35 - 55 - 60 - 68 - 80 EU IN SET INSTALLATION (CODE: 3.033674) (UP TO A MAXIMUM OF FIVE APPLIANCES)

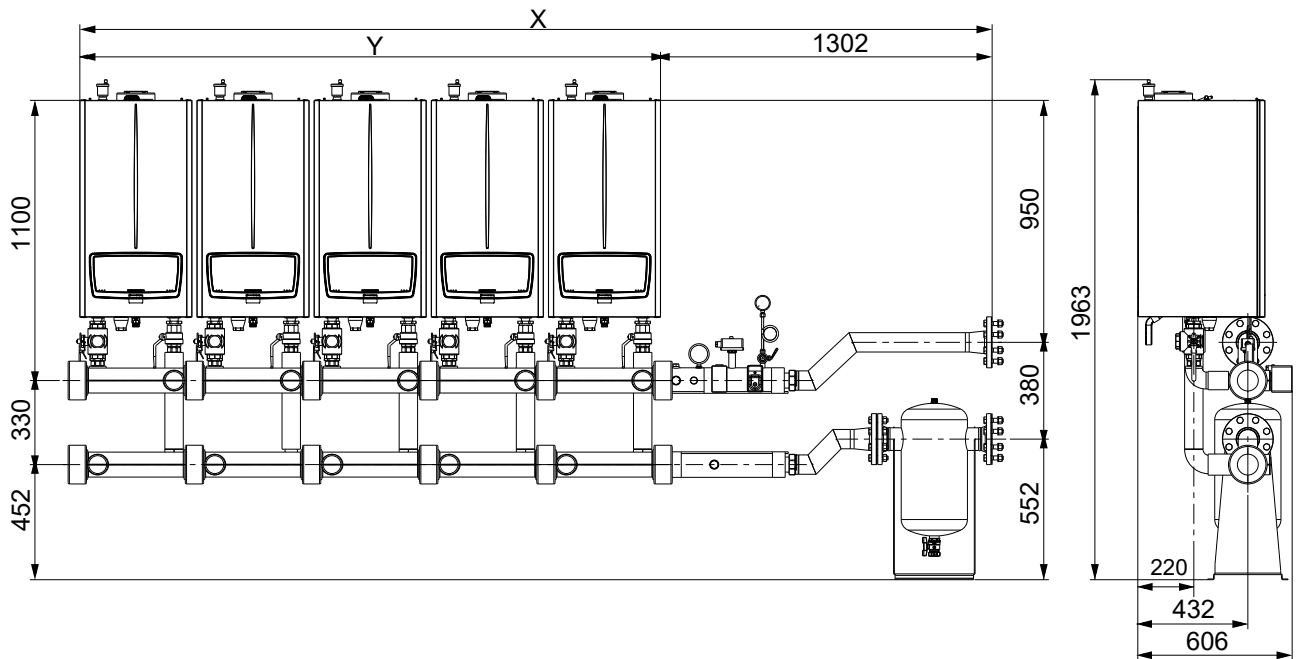

No. of Boilers	X	Y
N°2 VICTRIX PRO V2 EU	2202	900
N°3 VICTRIX PRO V2 EU	2662	1360
N°4 VICTRIX PRO V2 EU	3122	1820
N°5 VICTRIX PRO V2 EU	3582	2280

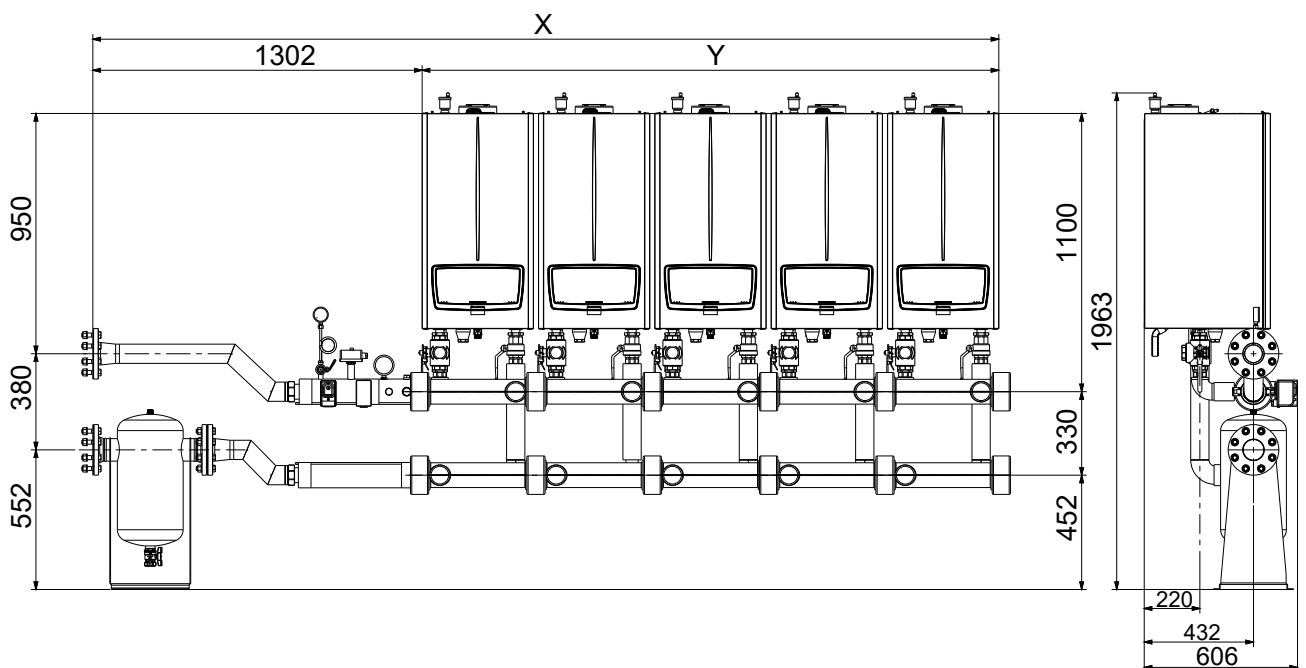

VICTRIX PRO V2 100 - 120 - 150 EU

21.4 DIMENSIONS AND CONNECTIONS WITH RH/LH SLUDGE REMOVER KIT FOR VICTRIX PRO V2 100 - 120 - 150 EU IN SET INSTALLATION (CODE: 3.033675) (UP TO A MAXIMUM OF FIVE APPLIANCES)

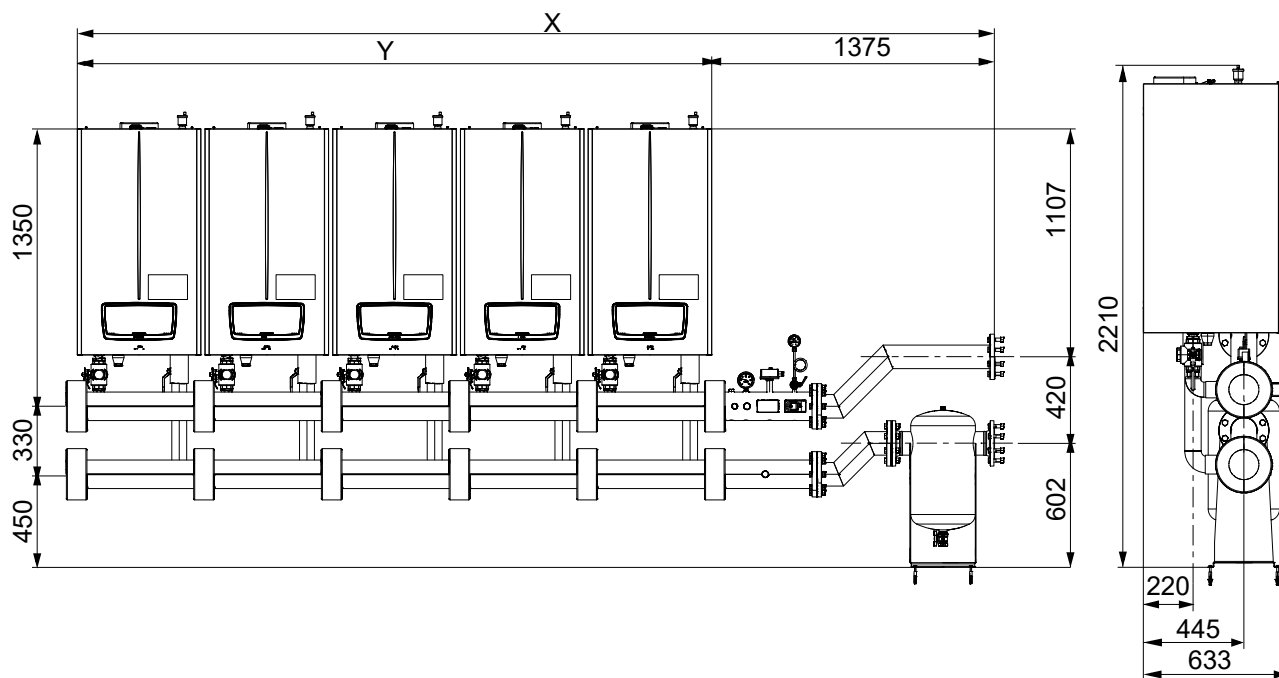

No. of Boilers	X	Y
N°2 VICTRIX PRO V2 EU	2595	1220
N°3 VICTRIX PRO V2 EU	3215	1840
N°4 VICTRIX PRO V2 EU	3835	2460
N°5 VICTRIX PRO V2 EU	4455	3080

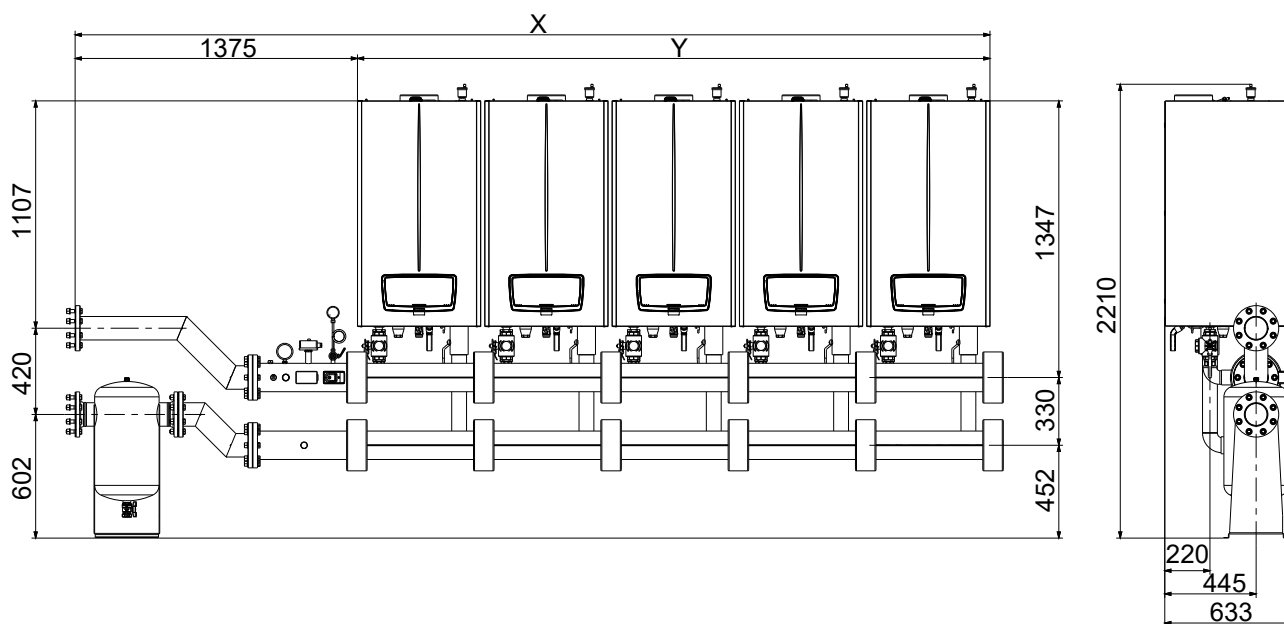

VICTRIX PRO V2 180 EU

21.5 DIMENSIONS AND CONNECTIONS WITH RH/LH SLUDGE REMOVER KIT FOR VICTRIX PRO V2 180 E IN SET INSTALLATION (CODE: 3.033675) (UP TO A MAXIMUM OF FIVE APPLIANCES)

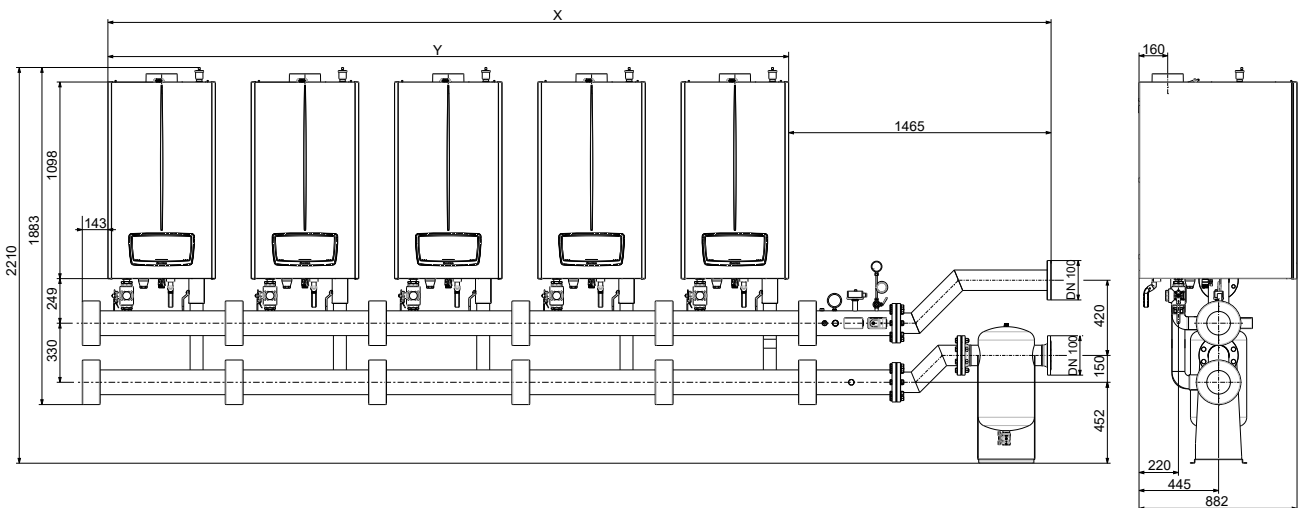

No. of Boilers	X	Y
N°2 VICTRIX PRO V2 EU	2865	1400
N°3 VICTRIX PRO V2 EU	3665	2200
N°4 VICTRIX PRO V2 EU	4465	3000
N°5 VICTRIX PRO V2 EU	5265	3800

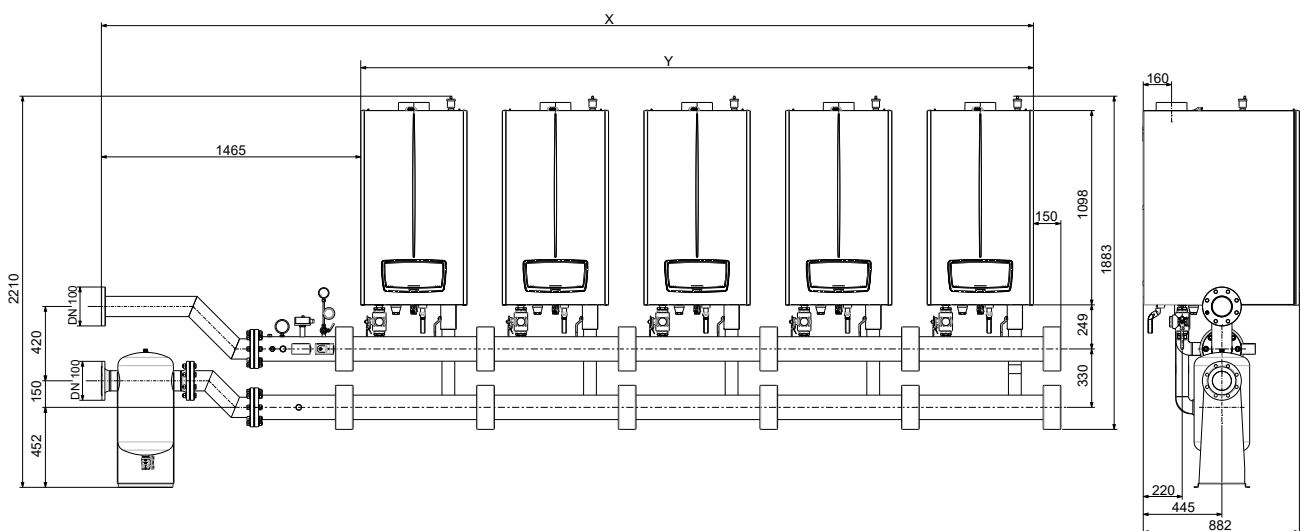

22 "FREE STANDING" SUPPORTING FRAME KIT FOR VICTRIX PRO V2 EU

The new VICTRIX PRO V2 EU range, except for the PRO V2 180 EU model, can be installed on a specific modular supporting frame which offers single or set installation (up to 5 boilers), in linear set-up, or back-to-back for more limited spaces. Two codes for the entire range: 3.032347 for PRO V2 35 - 55 - 60 - 68 - 80 EU models and 3.033686 for

PRO V2 100 - 120 - 150 EU models. The frames have supporting collars for the hydraulic manifolds and can be attached to the floor with plugs (not included). Thanks to a surface treatment, the frames are also type-approved for outdoor open-air installation.

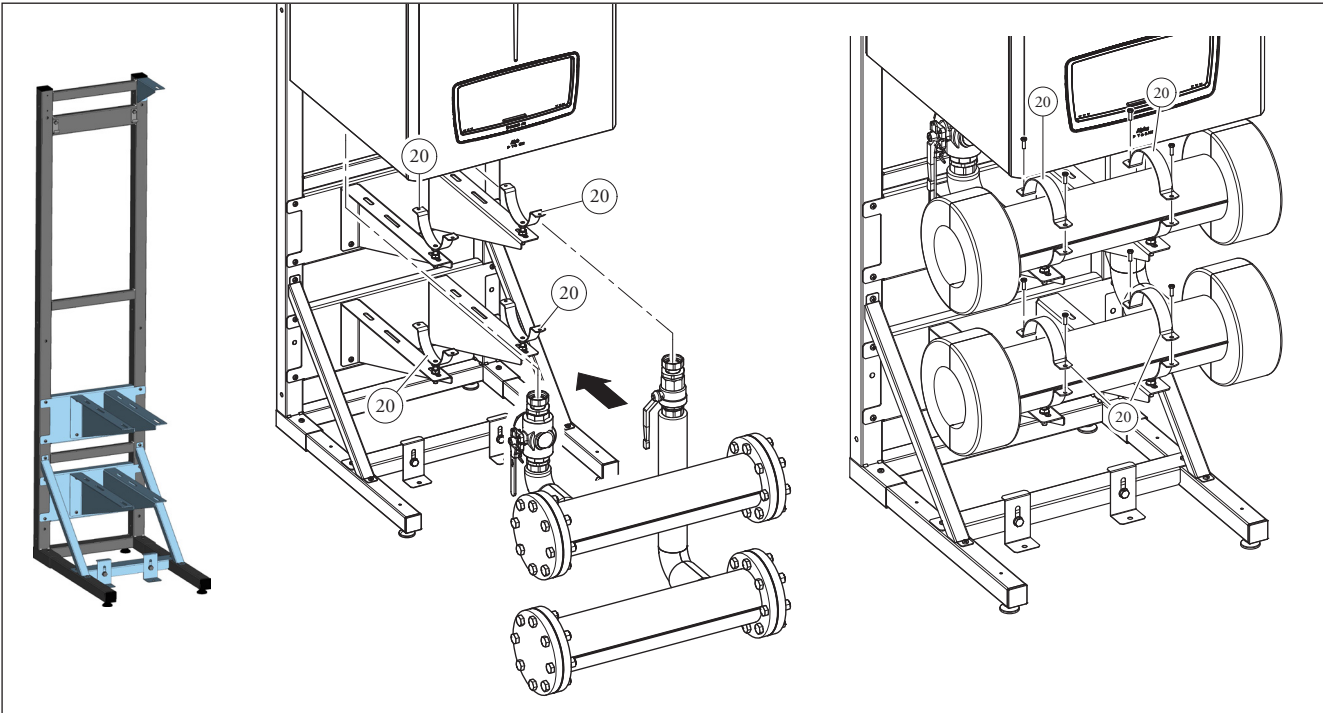

VICTRIX PRO V2 35 - 55 - 60 - 68 - 80 EU

VICTRIX PRO V2 100 - 120 - 150 EU

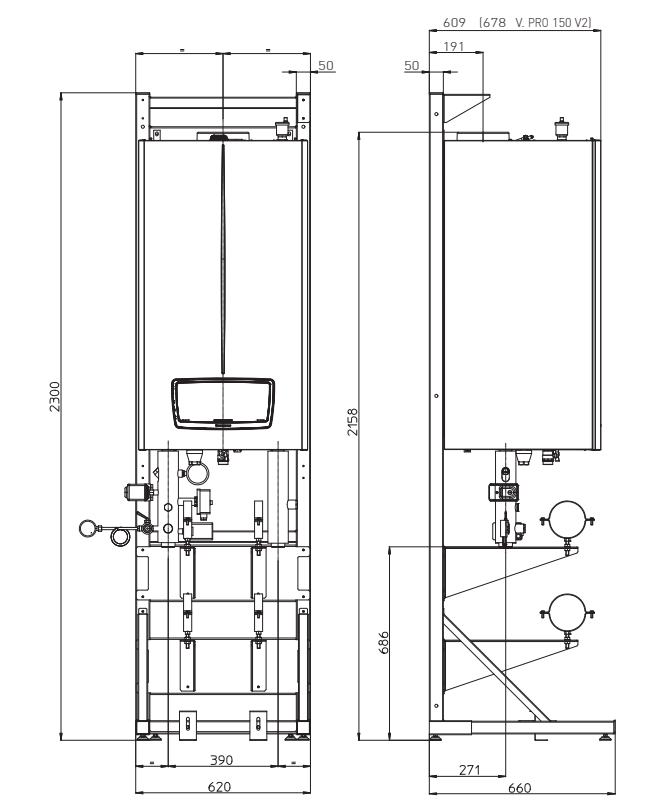
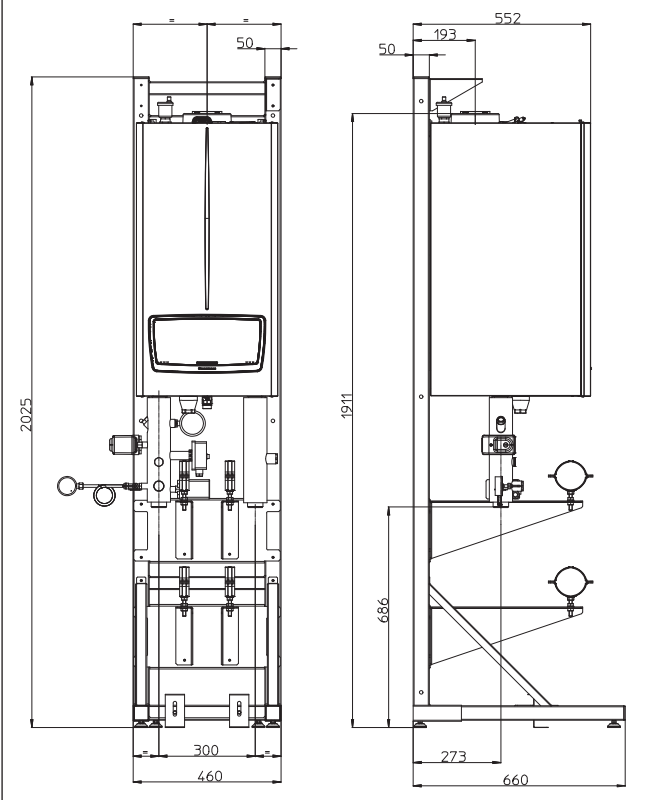

VICTRIX PRO V2 35 - 55 - 60 - 68 - 80 EU

23

**DIMENSIONS AND CONNECTIONS (OPTIONAL) WITH VICTRIX PRO V2
35 - 55 - 60 - 68 - 80 EU KIT WITH INSTALLATION ON
SUPPORTING FRAME SET UP IN LINE (UP TO A MAXIMUM OF 5 APPLIANCES)**

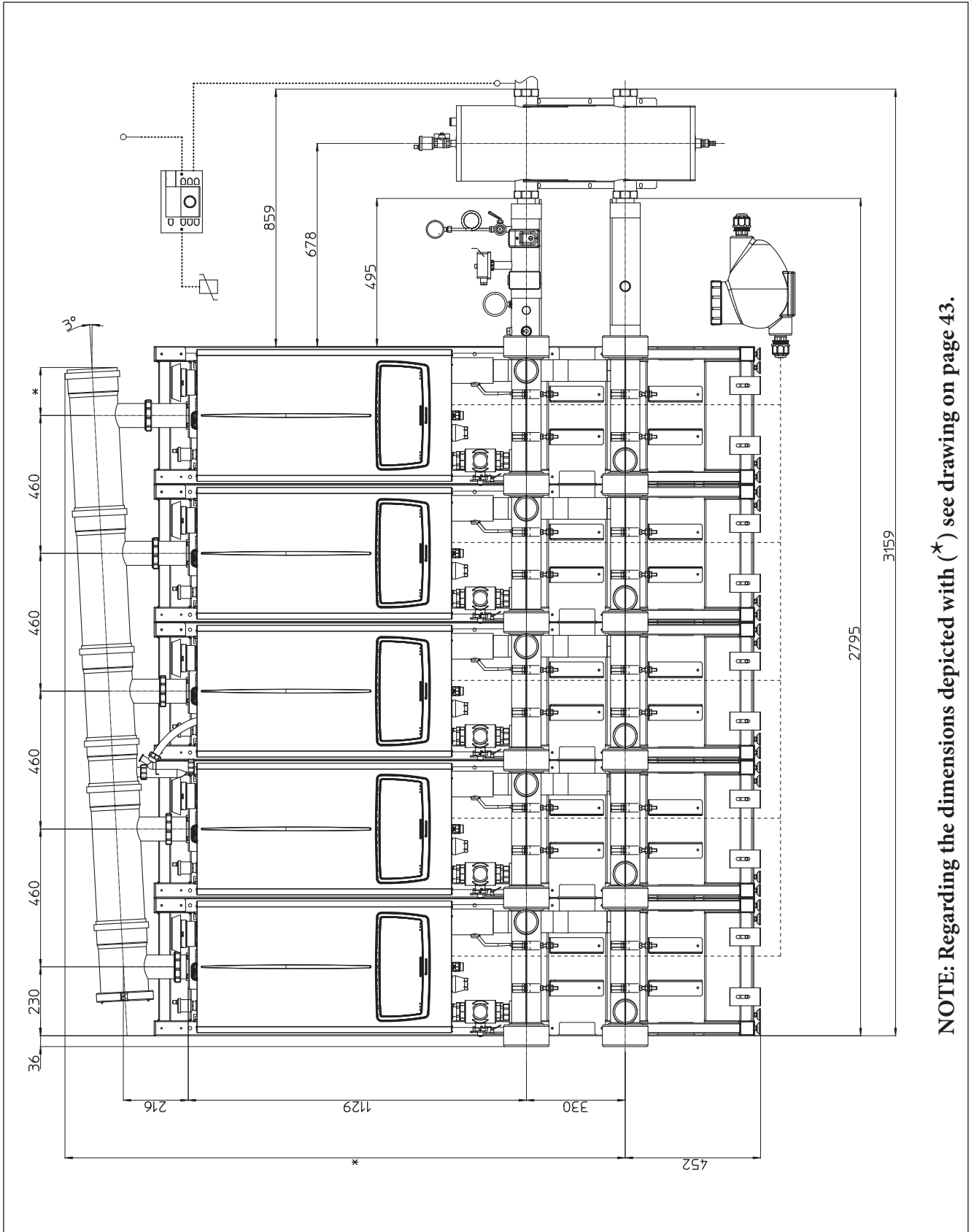

NOTE: Regarding the dimensions depicted with (*) see drawing on page 43.

VICTRIX PRO V2 35 - 55 - 60 - 68 - 80 EU

**23.1 KIT DIMENSIONS AND CONNECTIONS (OPTIONAL) VICTRIX PRO V2
35 - 55 - 60 - 68 - 80 E WITH INSTALLATION ON SUPPORTING FRAME SET UP
BACK-TO-BACK (UP TO A MAXIMUM OF 5 APPLIANCES IN LINE WITH SINGLE INAIL KIT)**

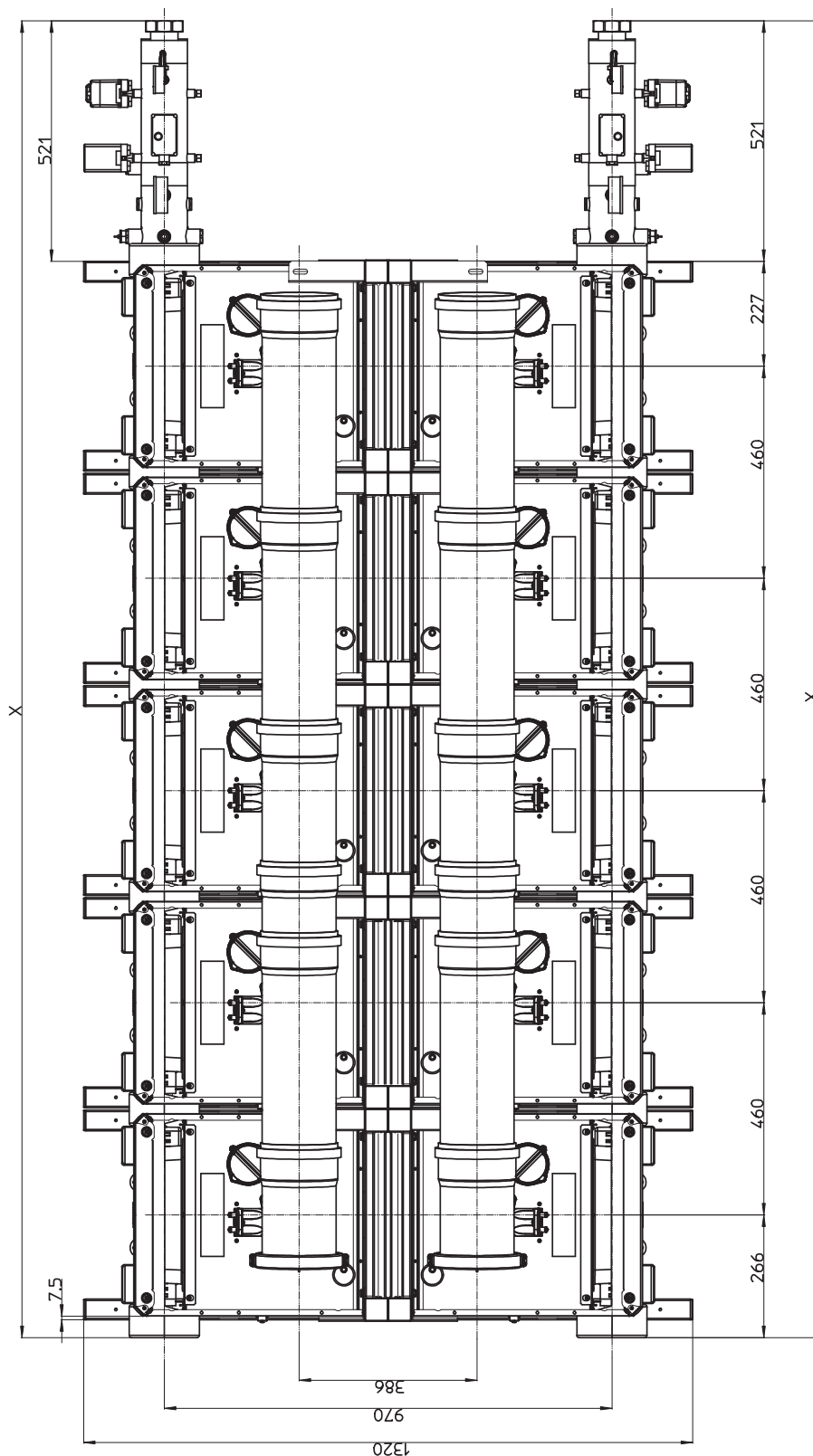

Reference	2 boilers	3 boilers	4 boilers	5 boilers
X	1477	1937	2397	2857

VICTRIX PRO V2 100 - 120 - 150 EU

23.2 DIMENSIONS AND CONNECTIONS WITH (OPTIONAL) VICTRIX PRO V2 100 - 120 - 150 EU KIT WITH INSTALLATION ON SUPPORTING FRAME SET UP IN LINE (UP TO A MAXIMUM OF 5 APPLIANCES)

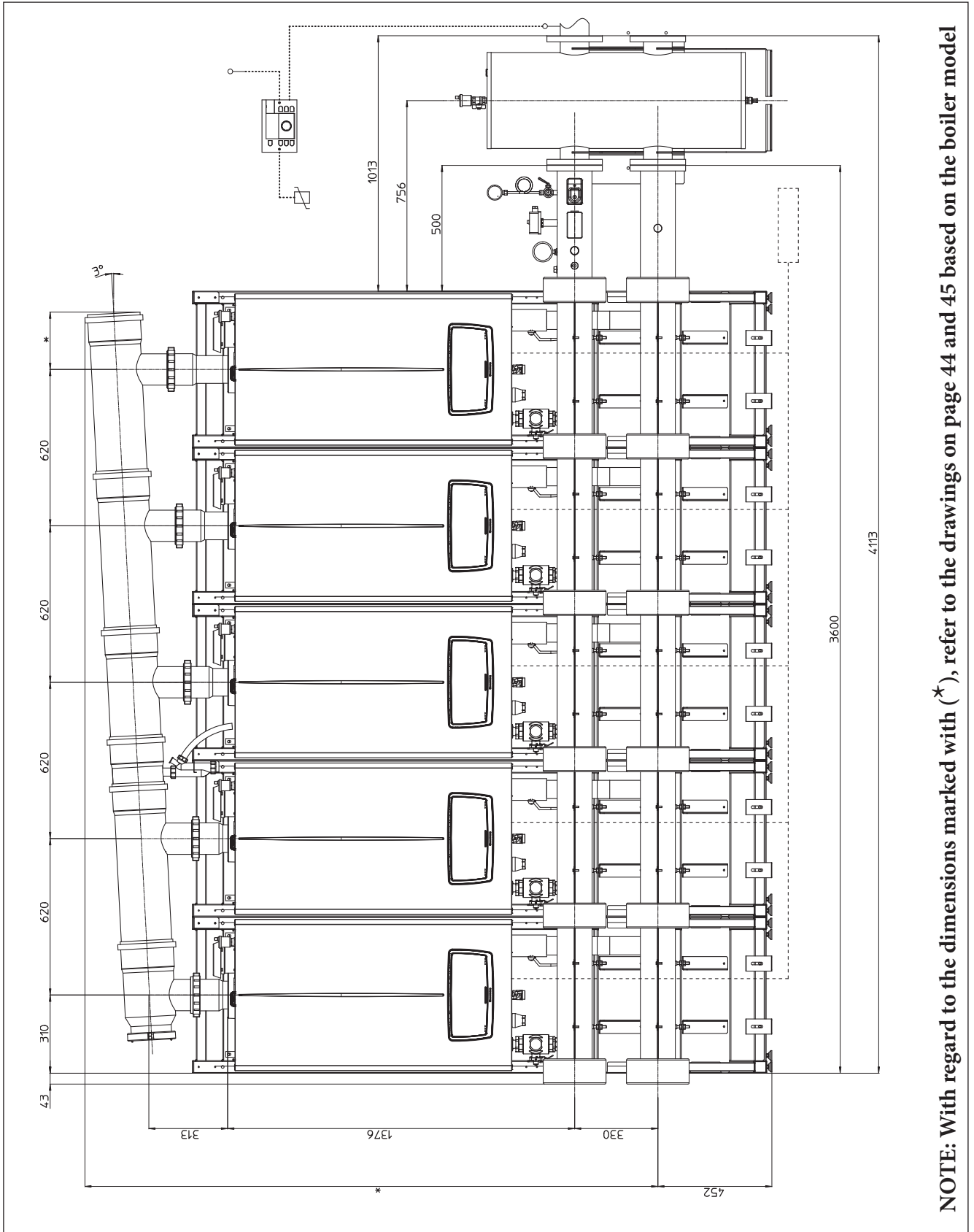

VICTRIX PRO V2 100 - 120 - 150 EU

23.3 DIMENSIONS AND CONNECTIONS WITH (OPTIONAL) VICTRIX PRO V2 100 - 120 EU KIT WITH INSTALLATION ON SUPPORTING FRAME SET UP BACK-TO-BACK (UP TO A MAXIMUM OF 5 APPLIANCES IN LINE WITH SINGLE INAIL KIT)

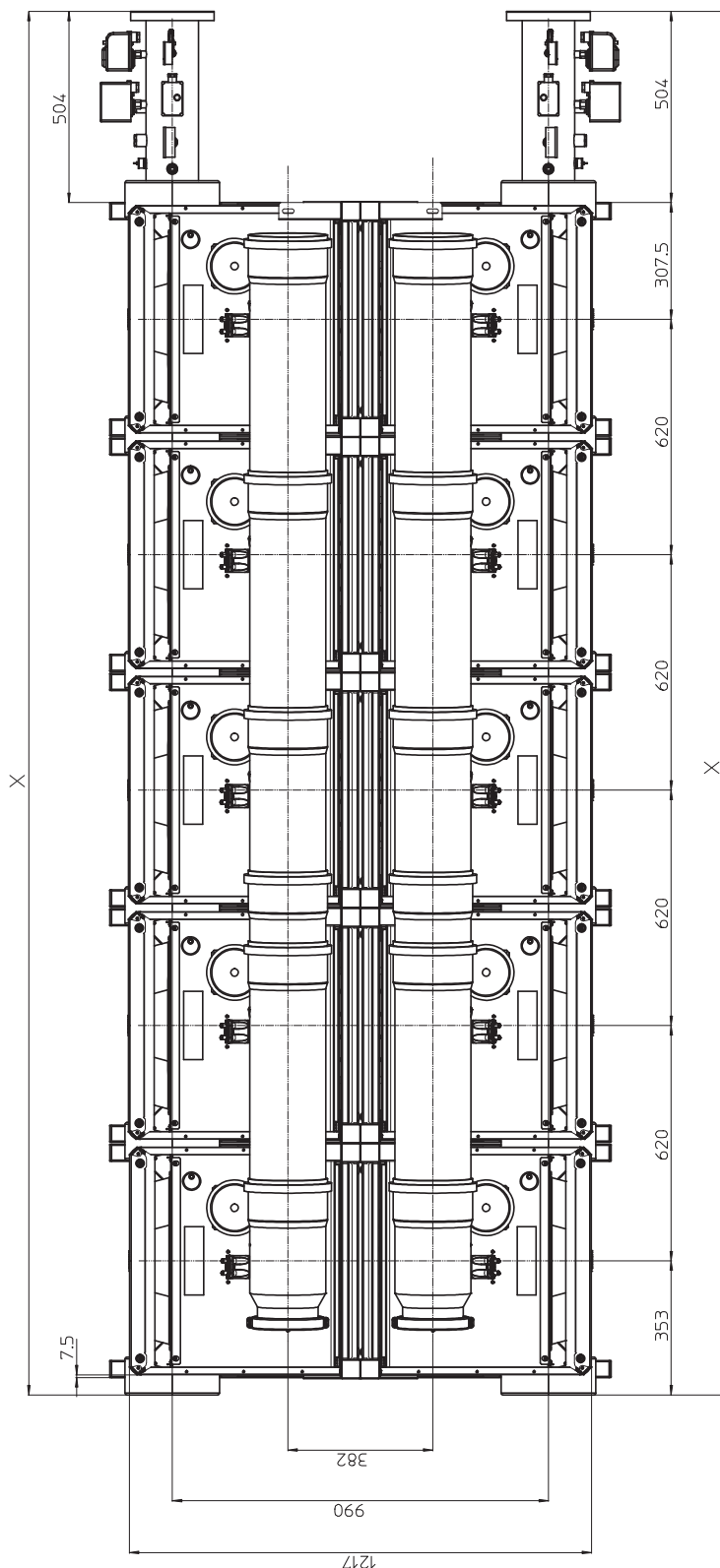

Reference	2 boilers	3 boilers	4 boilers	5 boilers
X	1795	2415	3035	3655

VICTRIX PRO V2 100 - 120 - 150 EU

23.4 DIMENSIONS AND CONNECTIONS WITH (OPTIONAL) VICTRIX PRO V2 150 EU KIT WITH INSTALLATION ON SUPPORTING FRAME SET UP BACK-TO-BACK (UP TO A MAXIMUM OF 5 APPLIANCES IN LINE WITH SINGLE INAIL KIT)

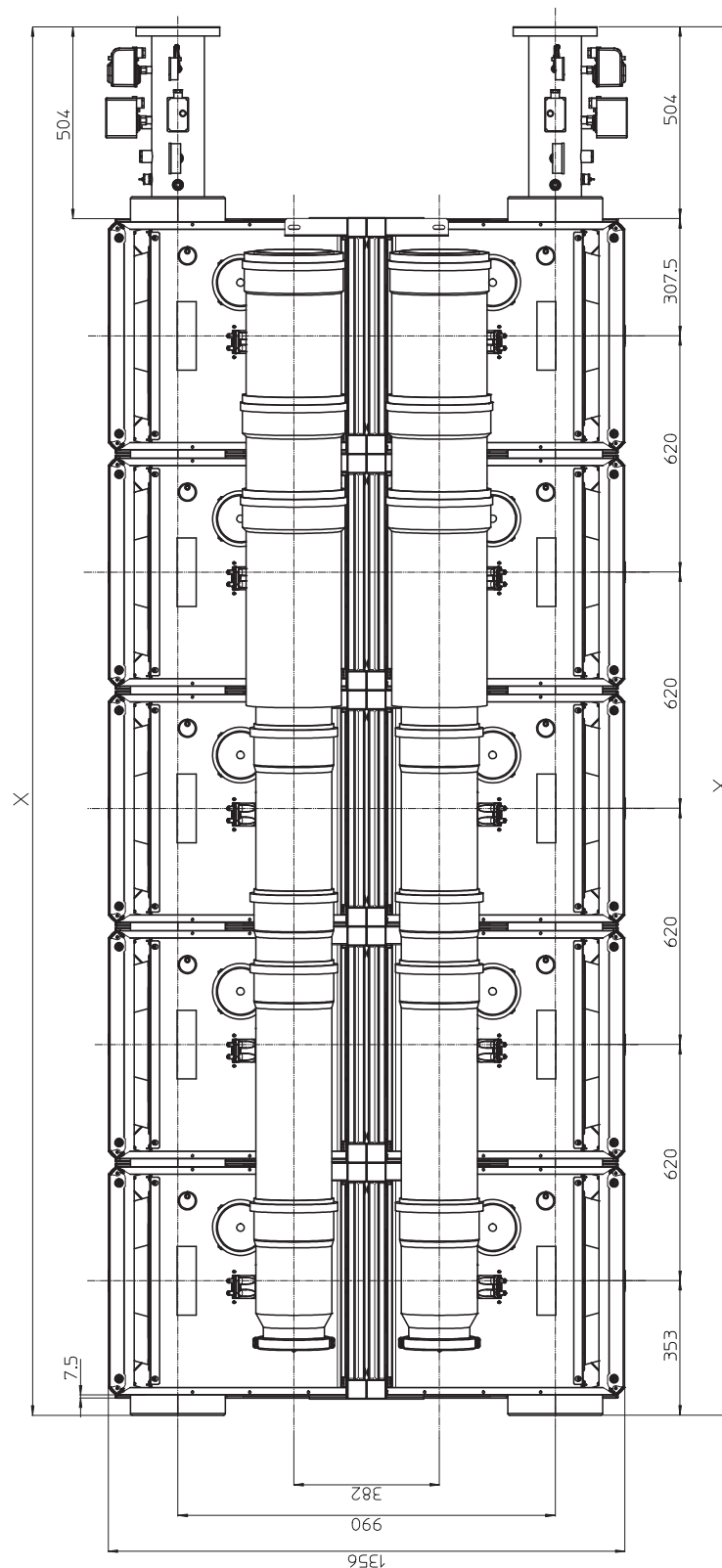

Reference	2 boilers	3 boilers	4 boilers	5 boilers
X	1795	2415	3035	3655

VICTRIX PRO V2 EU boilers are type-approved for installation inside the heating control unit or outside in a sheltered or uncovered area.

These generators leave the factory in type “C5 - C8” sealed chamber and fan assisted configuration.

They can be adapted to open chamber and fan assisted type B23 (according to standard UNI EN 1749), using specific kits for direct air intake from the room in which the appliance is installed, by means of a suction mushroom or thermoformed cover and the flue gas is exhausted in a single chimney or directly outside.

By varying the type of installation the classification of the boiler also varies:

- **Type C sealed chamber and fan assisted configuration**, using specific concentric or split kits, as depicted further on (from page 76 to page 80).

- **Type B open chamber and fan assisted configuration**, in this case too by means of specific kits depicted further on (from page 81 to page 87).

24.1 CONCENTRIC KITS INSTALLATION (NOT FORESEEN FOR VICTRIX PRO V2 180 EU)

In order to be able to install the concentric kits, it is necessary to remove the factory fitted cap on the concentric intake.

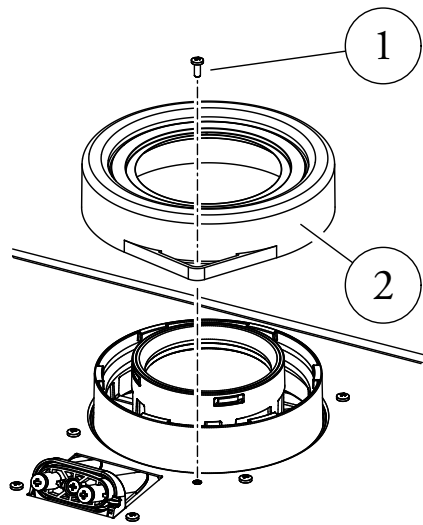

Key:

- 1 - Screw
- 2 - Concentric intake cap

Using the concentric flue kits, the generator takes on the type C sealed chamber and fan assisted configuration.

The concentric terminals indicated on the following pages allow air to be suctioned and flue gas to be exhausted directly outside the home, regardless of whether intake kits or wall or roof flue exhausts are used.

The horizontal kits can be installed with the rear, right side, left side and front outlet, making sure that the metal plates or silicone buffer wall sealing plates are correctly installed, fastening them appropriately until flush with the inside and outside wall.

VICTRIX PRO V2 EU

24.2

HORIZONTAL CONCENTRIC KIT

To calculate the length of the flue, simply add the corresponding “length equivalent to 1 m of pipe” value for each component to be used until the maximum allowed length for each product is reached. These data are provided in the specific technical documentation supplied with each “Use and maintenance booklet”.

The maximum length that can be travelled “L” are displayed in the summary tables on pages 88 and 89.

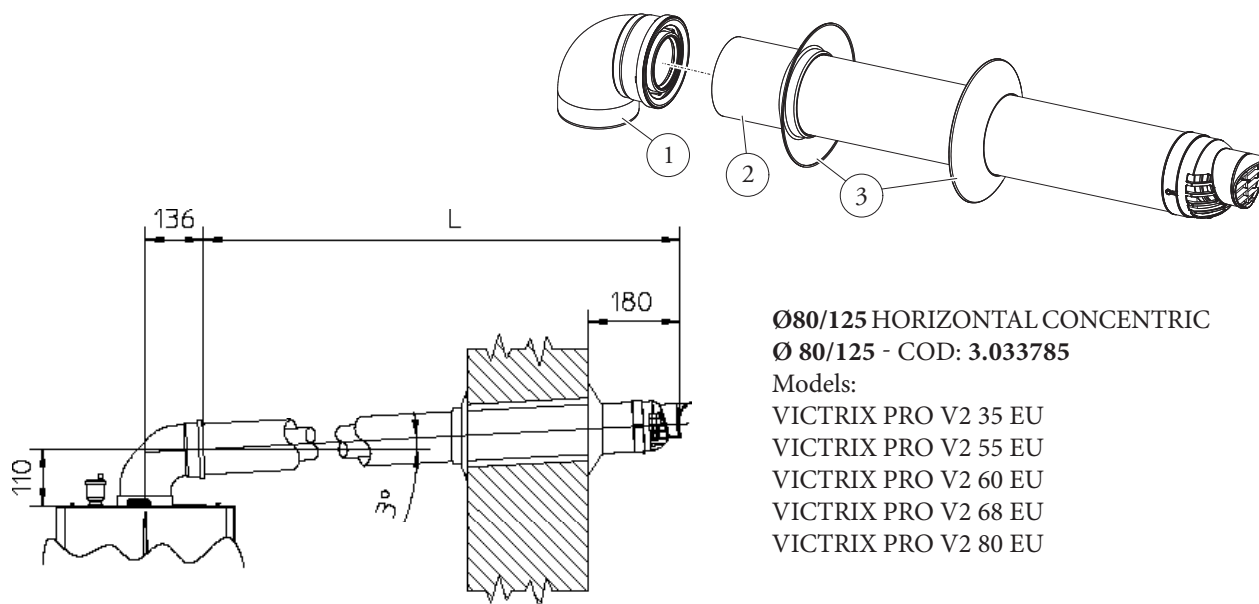

Ø80/125 HORIZONTAL CONCENTRIC

Ø 80/125 - COD: 3.033785

Models:

VICTRIX PRO V2 35 EU

VICTRIX PRO V2 55 EU

VICTRIX PRO V2 60 EU

VICTRIX PRO V2 68 EU

VICTRIX PRO V2 80 EU

Key:

1 - n. 1 87° concentric bend Ø 80/125 or Ø 110/160

2 - n. 1 concentric intake/exhaust terminal Ø 80/125 or Ø 110/160

3 - n. 2 silicone wall sealing plates or n. 2 wall terminal plates

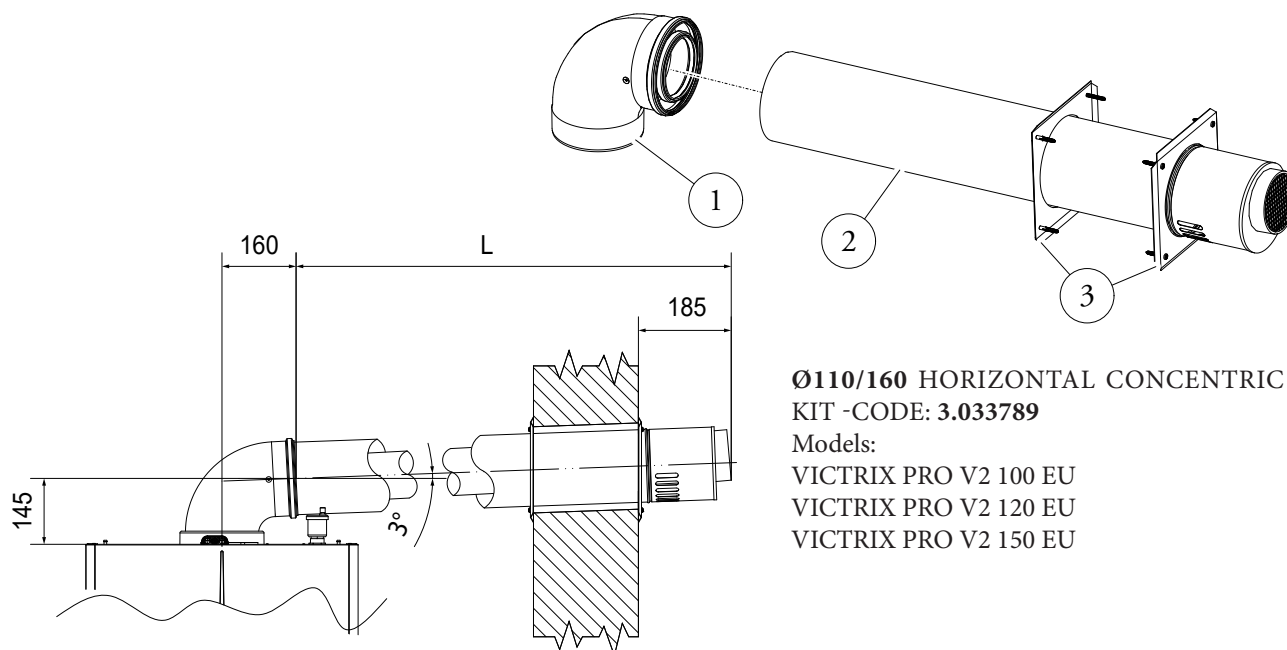

Ø110/160 HORIZONTAL CONCENTRIC KIT -CODE: 3.033789

Models:

VICTRIX PRO V2 100 EU

VICTRIX PRO V2 120 EU

VICTRIX PRO V2 150 EU

24.3

VERTICAL CONCENTRIC KIT

To calculate the length of the flue, simply add the corresponding “length equivalent to 1 m of pipe” value for each component to be used until the maximum allowed length for each product is reached. These data are provided in the specific technical documentation supplied with each “Use and maintenance booklet”.

The maximum length that can be travelled “L” are displayed in the summary tables on pages 88 and 89.

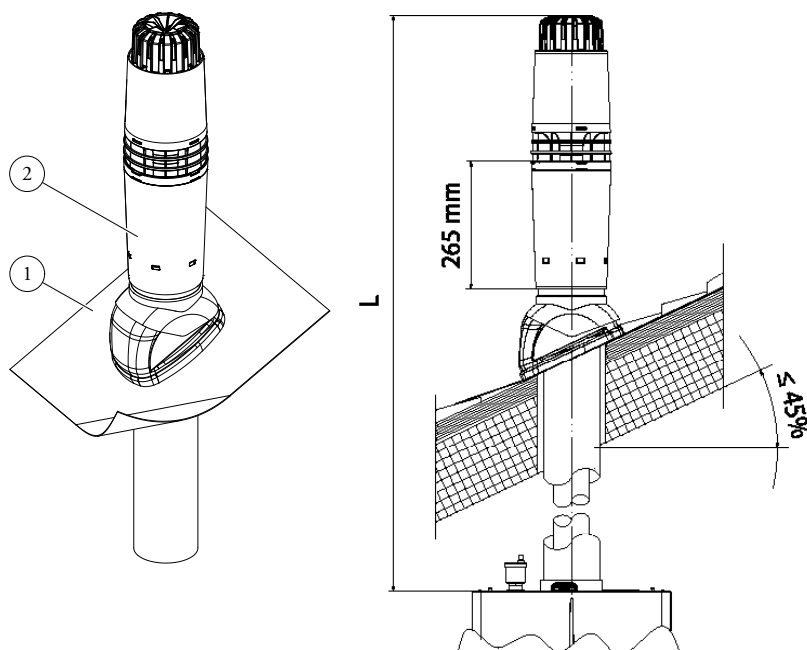

80/125 VERTICAL CONCENTRIC KIT- CODE: 3.033786

Models:

- VICTRIX PRO V2 35 EU
- VICTRIX PRO V2 55 EU
- VICTRIX PRO V2 60 EU
- VICTRIX PRO V2 68 EU
- VICTRIX PRO V2 80 EU

Key:

- 1 - n. 1 aluminium valley gutter Ø 80 or Ø 110
- 2 - n. 1 concentric intake/exhaust terminal Ø 80/125 or Ø 110/160

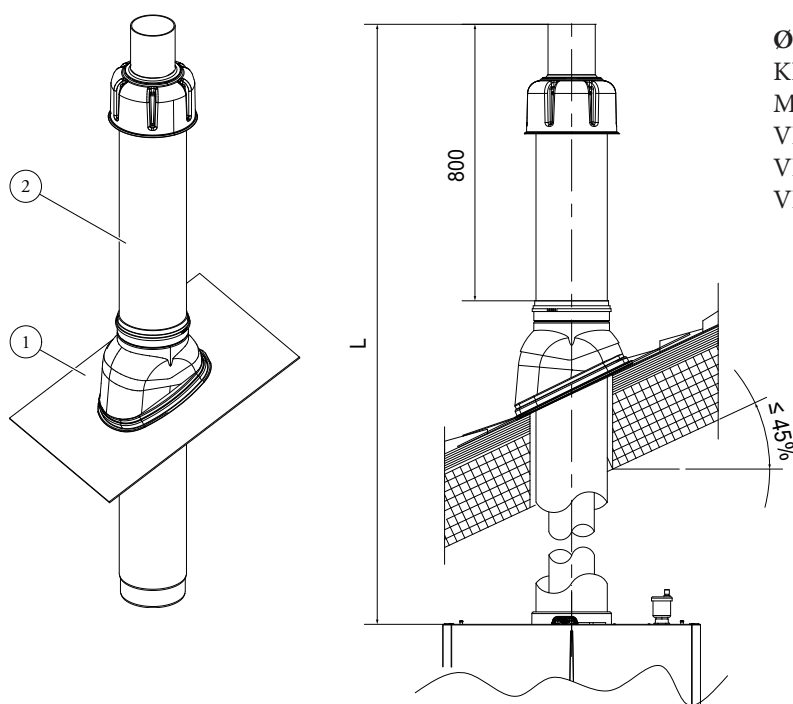

Ø 110/160 VERTICAL CONCENTRIC KIT- CODE: 3.033790

Models:

- VICTRIX PRO V2 100 EU
- VICTRIX PRO V2 120 EU
- VICTRIX PRO V2 150 EU

VICTRIX PRO V2 EU

24.4

HORIZONTAL SEPARATOR KIT

To calculate the length of the flue, simply add the corresponding “length equivalent to 1 m of pipe” value for each component to be used until the maximum allowed length for each product is reached. These data are provided in the specific technical documentation supplied with each “Use and maintenance booklet”.

The maximum length that can be travelled “L” are displayed in the summary tables on pages 88 and 89.

SEPARATOR KIT

Ø 80/80 - CODE: 3.012002

Models:

VICTRIX PRO V2 35 EU

VICTRIX PRO V2 55 EU

VICTRIX PRO V2 60 EU

VICTRIX PRO V2 68 EU

VICTRIX PRO V2 80 EU

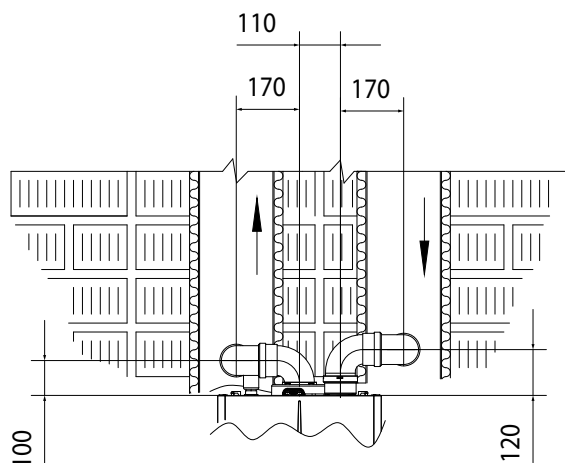
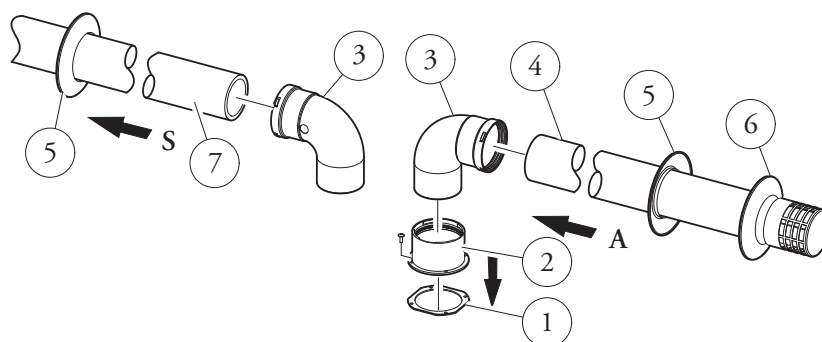

Key:

- 1 - n. 1 Intake gasket
- 2 - n. 1 Flanged stub pipe
- 3 - n. 2 90° bends Ø 80
- 4 - n. 1 Intake terminal Ø 80
- 5 - n. 2 internal silicone wall sealing plates
- 6 - n. 1 external silicone wall sealing plate
- 7 - n. 1 Drain pipe Ø 80

SEPARATOR KIT
Ø 100/100 - CODE: 3.032717
 Models:
 VICTRIX PRO V2 100 EU
 VICTRIX PRO V2 120 EU
 VICTRIX PRO V2 150 EU

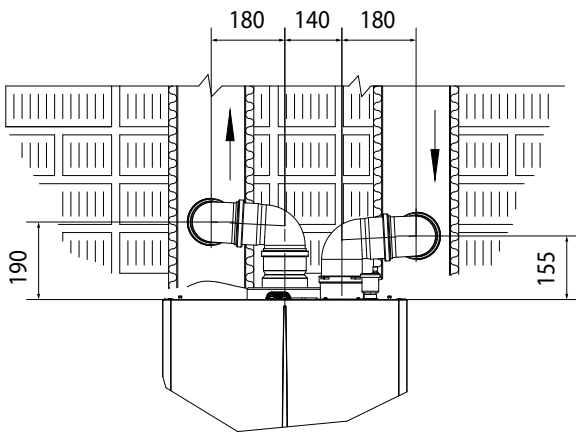
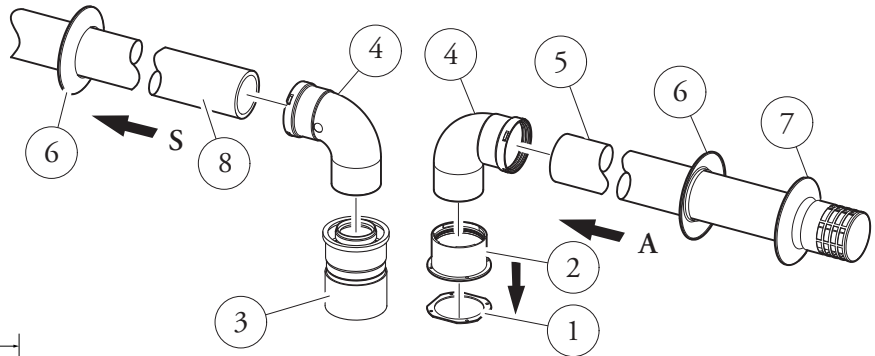

Key:

- 1 - n. 1 Intake gasket
- 2 - n. 1 Flanged stub pipe
- 3 - n. 1 reduction Ø 110 - Ø 100
- 4 - n. 2 90° bends Ø 100
- 5 - n. 1 intake terminal Ø 100
- 6 - n. 2 internal silicone wall sealing plates
- 7 - n. 1 external silicone wall sealing plate
- 8 - n. 1 drain pipe Ø 100

SEPARATOR KIT
Ø 160/160 - CODE: 3.035122
 Model:
 VICTRIX PRO V2 180 EU

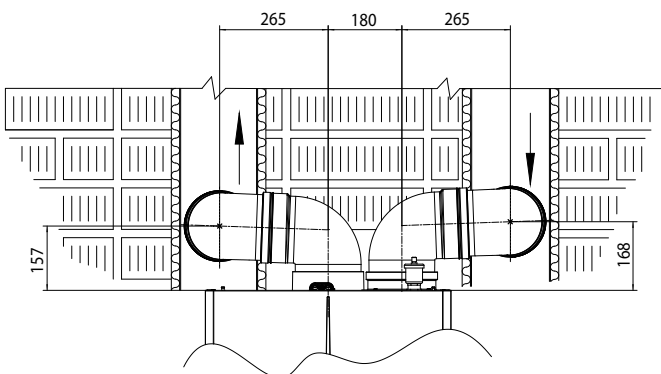
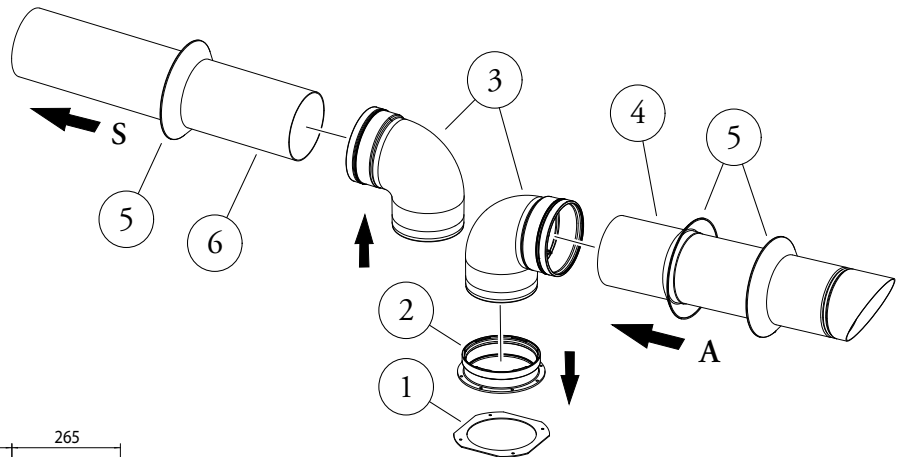

Key:

- 1 - n. 1 Intake gasket
- 2 - n. 1 Flanged stub pipe
- 3 - n. 2 90° bends Ø 160
- 4 - n. 1 intake terminal Ø 160
- 5 - n. 3 silicone wall sealing plates
- 6 - n. 1 drain pipe Ø 160

VICTRIX PRO V2 EU

24.5

INSTALLATION OF THE INTAKE STUB PIPE KIT

To be able to install the intake stub type kit for type B configurations (open chamber and fan assisted), the factory installed plug, placed above the sealed chamber next to the flue exhaust flange, must be removed (see image below).

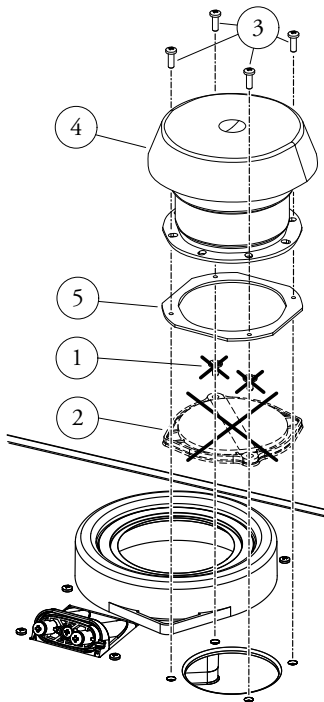

Key:

- 1 - Suction cap fixing screws
- 2 - Intake cap
- 3 - Stub pipe kit fixing screws
- 4 - Intake stub pipe
- 5 - Stub pipe gasket

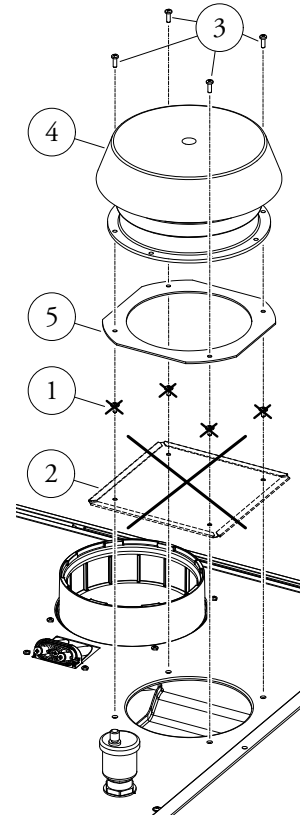

**INTAKE STUB PIPE KIT
Ø 80 - CODE: 3.033759**

Models:

VICTRIX PRO V2 35 EU
VICTRIX PRO V2 55 EU
VICTRIX PRO V2 60 EU
VICTRIX PRO V2 68 EU
VICTRIX PRO V2 80 EU

**INTAKE STUB PIPE KIT
Ø 100 - CODE: 3.033760**

Models:

VICTRIX PRO V2 100 EU
VICTRIX PRO V2 120 EU
VICTRIX PRO V2 150 EU

**INTAKE STUB PIPE KIT
Ø 160 - CODE: 3.034565**

Model:

VICTRIX PRO V2 180 EU

This kit allows you to use pipes for flow exhaust only, as the generator takes on the type B open chamber and fan assisted configuration.

The terminals, pipes and special pieces indicated in the following pages allow the flue gas to be exhausted outside the home, through chimneys, piped systems or vertical and horizontal exhaust terminals.

The horizontal pipes can be installed with the rear, right side, left side and front outlet, making sure that the metal plates or silicone buffer wall sealing plates are correctly installed, fastening them appropriately until flush with the inside and outside wall.

24.6

VERTICAL EXHAUST KIT

To calculate the length of the flue, simply add the corresponding “length equivalent to 1 m of pipe” value for each component to be used until the maximum allowed length for each product is reached. These data are provided in the specific technical documentation supplied with each “Use and maintenance booklet”.

The maximum length that can be travelled “L” are displayed in the summary tables on pages 88 and 89.

FLUE GAS EXHAUST KIT Ø 80

CODE: 3.034579

CODE: 3.024295 in stainless steel

Models:

VICTRIX PRO V2 35 EU

VICTRIX PRO V2 55 EU

VICTRIX PRO V2 60 EU

VICTRIX PRO V2 68 EU

VICTRIX PRO V2 80 EU

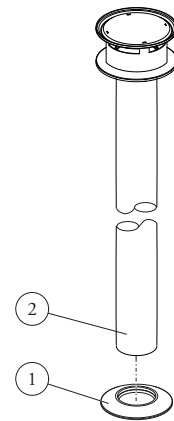
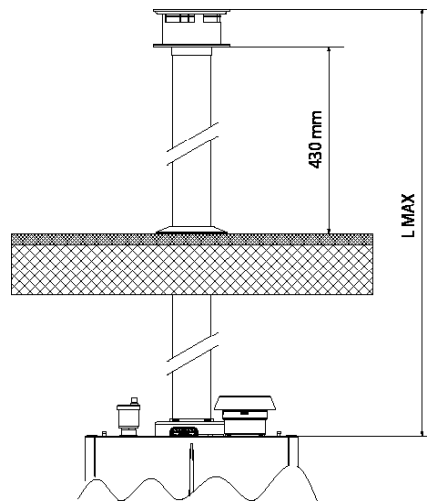
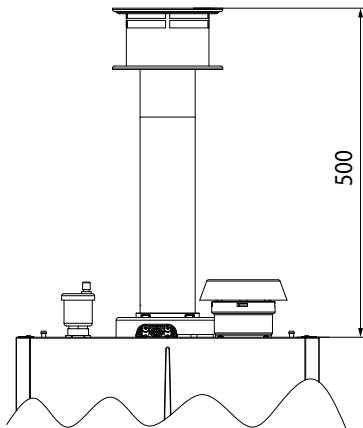

Key:

- 1 - n. 1 silicone wall sealing plate
- 2 - n. 1 exhaust terminal Ø 80

N.B.:

the stainless steel terminal protrudes 930 mm above the flue flange of the generator and cannot be shortened

VICTRIX PRO V2 EU

FLUE GAS EXHAUST KIT Ø 100

CODE: 3.032713

CODE: 3.032714 in Stainless steel

Models:

VICTRIX PRO V2 100 EU

VICTRIX PRO V2 120 EU

VICTRIX PRO V2 150 EU

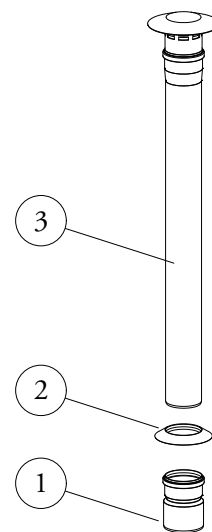
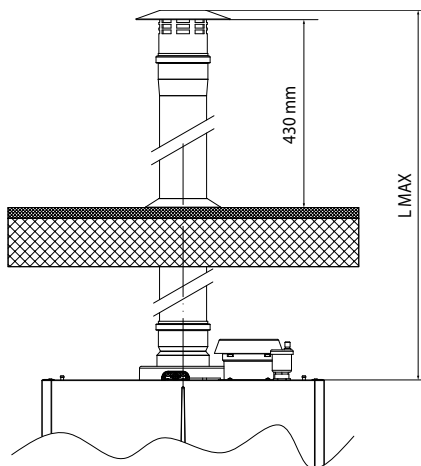
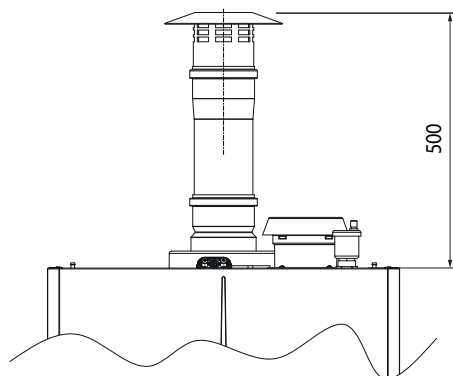

Key:

1 - n. 1 reduction Ø 110 - Ø 100

2 - n. 1 internal silicone wall sealing plate

3 - n. 1 exhaust terminal Ø 100

N.B.:

the stainless steel terminal protrudes 525 mm above the Ø 110 - 100 reduction placed above the flue flange of the generator and cannot be shortened

FLUE GAS EXHAUST KIT Ø 160

CODE: 3.034554

CODE: 3.034555 in stainless steel

Models:

VICTRIX PRO V2 180 EU

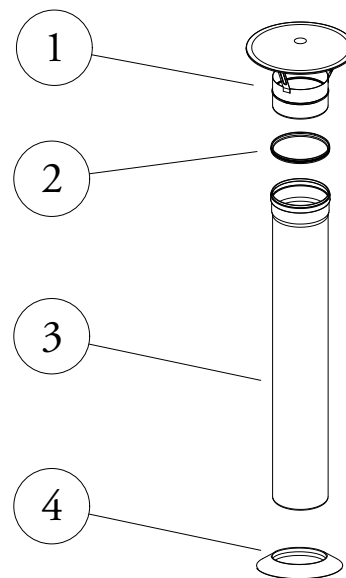
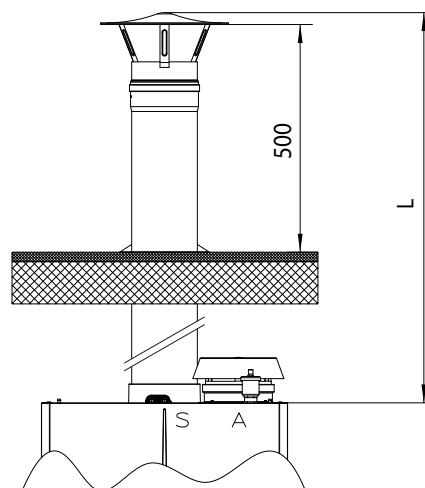
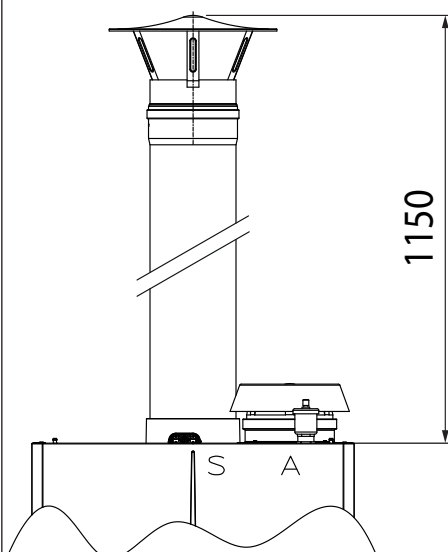

Key:

1 - n. 1 exhaust terminal Ø 160

2 - n. 1 gasket Ø 160

3 - n. 1 drain pipe Ø 160

4 - n. 1 Wall sealing plate

24.7

HORIZONTAL WALL FLUE EXHAUST KIT

To calculate the length of the flue, simply add the corresponding “length equivalent to 1 m of pipe” value for each component to be used until the maximum allowed length for each product is reached. These data are provided in the specific technical documentation supplied with each “Use and maintenance booklet”.

The maximum length that can be travelled “L” are displayed in the summary tables on pages 88 and 89.

FLUE EXHAUST KIT

Ø 80 - CODE: 3.015255

Models:

VICTRIX PRO V2 35 EU

VICTRIX PRO V2 55 EU

VICTRIX PRO V2 60 EU

VICTRIX PRO V2 68 EU

VICTRIX PRO V2 80 EU

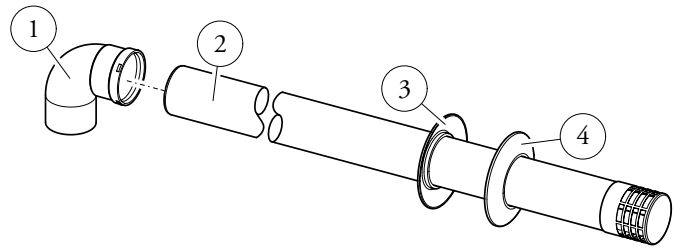
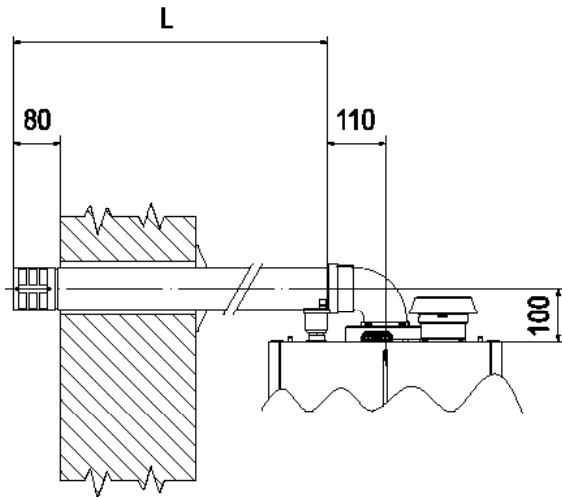

Key:

- 1 - n. 1 bend 90° Ø 80
- 2 - n. 1 exhaust terminal Ø 80
- 3 - n. 1 internal silicone wall sealing plate
- 4 - n. 1 external silicone wall sealing plate

FLUE EXHAUST KIT

Ø 100 - CODE: 3.032716

Models:

VICTRIX PRO V2 100 EU

VICTRIX PRO V2 120 EU

VICTRIX PRO V2 150 EU

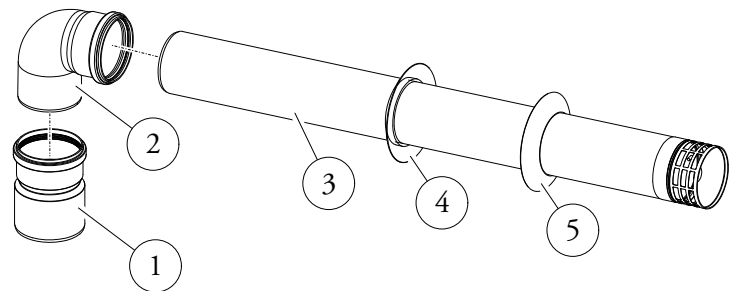
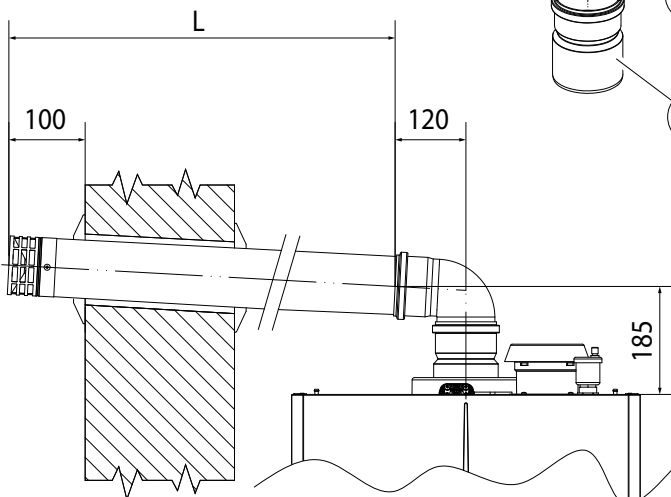

Key:

- 1 - n. 1 reduction Ø 110 - Ø 100
- 2 - n. 1 bend 90° Ø 100
- 3 - n. 1 exhaust terminal Ø 100
- 4 - n. 1 internal silicone wall sealing plate
- 5 - n. 1 external silicone wall sealing plate

VICTRIX PRO V2 EU

24.8

HORIZONTAL CHIMNEY FLUE EXHAUST KIT

To calculate the length of the flue, simply add the corresponding “length equivalent to 1 m of pipe” value for each component to be used until the maximum allowed length for each product is reached. These data are provided in the specific technical documentation supplied with each “Use and maintenance booklet”.

The maximum length that can be travelled “L” are displayed in the summary tables on pages 88 and 89.

FLUE EXHAUST KIT
 Ø 80 - CODE: 3.015254

Models:

VICTRIX PRO V2 35 EU

VICTRIX PRO V2 55 EU

VICTRIX PRO V2 60 EU

VICTRIX PRO V2 68 EU

VICTRIX PRO V2 80 EU

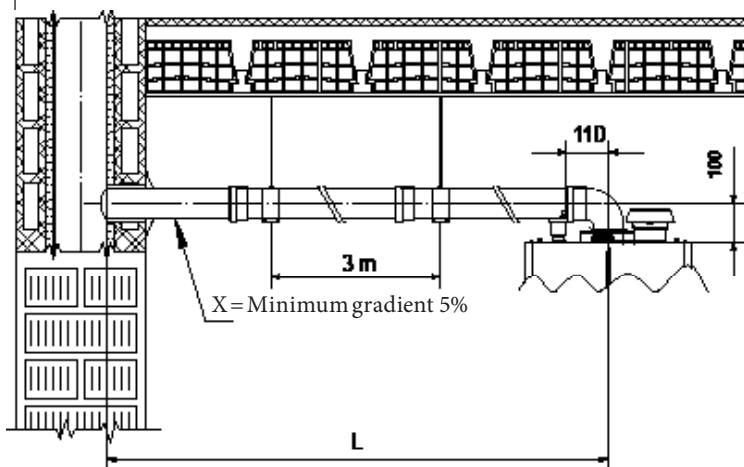
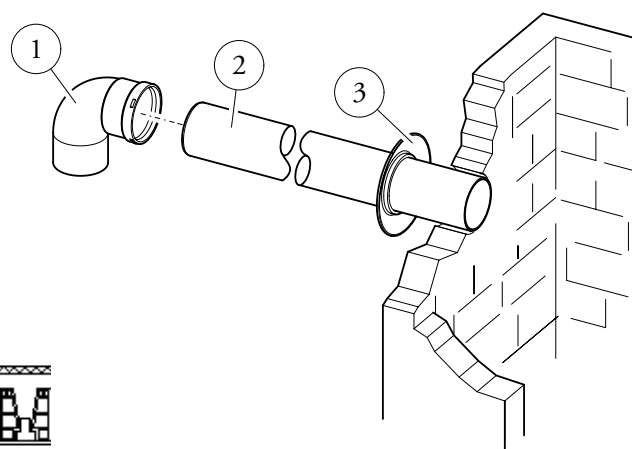

Key:

- 1 - n. 1 bend 90° Ø 80
- 2 - n. 1 drain pipe Ø 80
- 3 - n. 1 internal silicone wall sealing plate

FLUE EXHAUST KIT
Ø 100 - CODE: 3.032715
 Models:
 VICTRIX PRO V2 100 EU
 VICTRIX PRO V2 120 EU
 VICTRIX PRO V2 150 EU

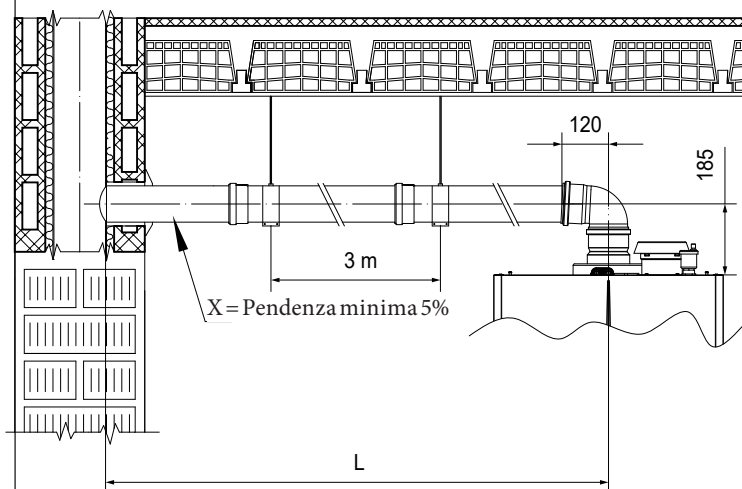
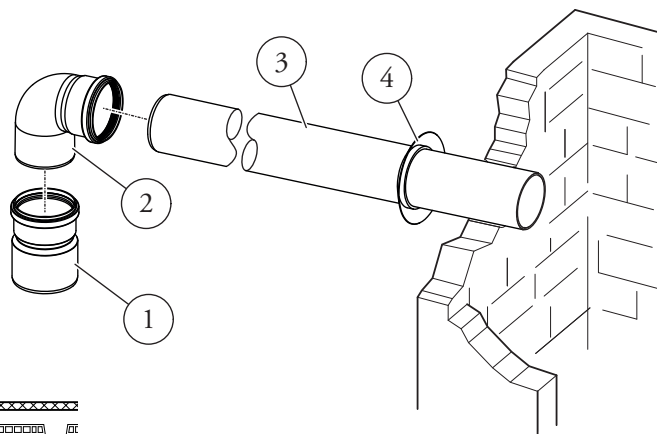

- Key:**
- 1 - n. 1 reduction Ø 110 - Ø 100
 - 2 - n. 1 bend 90° Ø 100
 - 3 - n. 1 drain pipe Ø 100
 - 4 - n. 1 internal silicone wall sealing plate

FLUE EXHAUST KIT
Ø 160 - CODE: 3.034556
 Model:
 VICTRIX PRO V2 180 EU

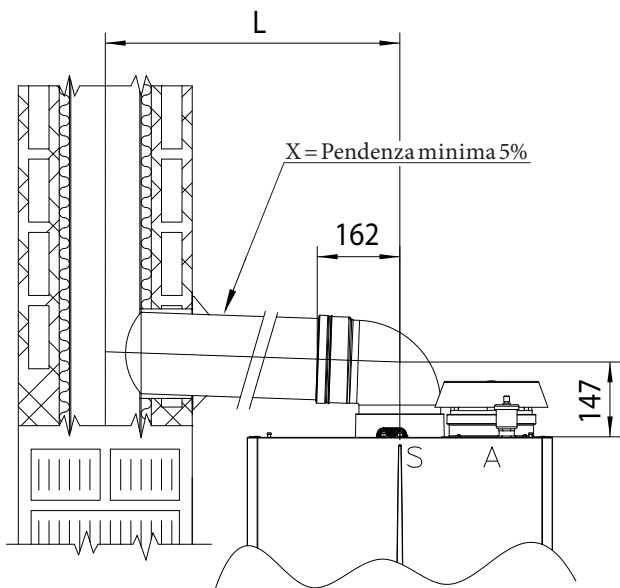
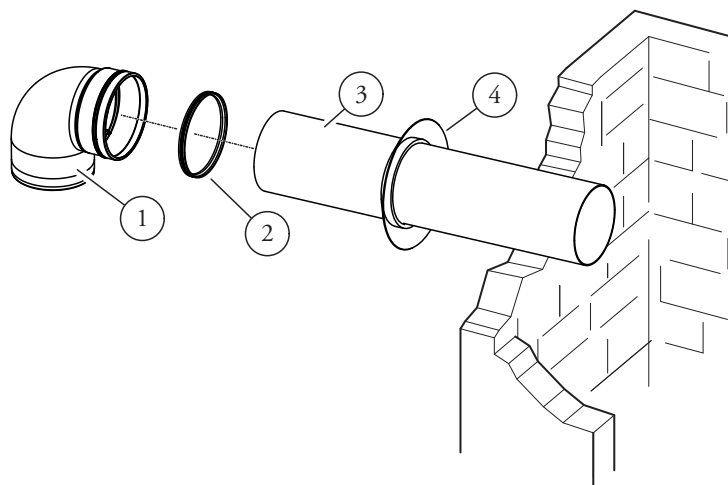

- Key:**
- 1 - n. 1 bend 90° Ø 160
 - 2 - n. 1 gasket
 - 3 - n. 1 drain pipe Ø 160
 - 4 - n. 1 internal silicone wall sealing plate

VICTRIX PRO V2 EU

24.9

TOP COVER KIT IPX5D

Configuration type B.

Using the relevant cover kit, direct air intake is possible and flue gas is exhausted into a single chimney or directly to the outside. In this configuration the appliance can be installed in a completely open place. The generator in this type B open chamber and fan assisted configuration can be classified as follows:

- the flue gas exhaust must be connected to a single chimney or ducted directly to the external atmosphere via a vertical terminal for direct exhaust (B₂₃) or via an Immergas ducting system (B₅₃) for the available models;
- B_{23p}, B_{53p}: type B₂₃ and B₅₃ installation with exhaust system designed to operate with positive pressure (check the head data of the fan of each model on the following pages).

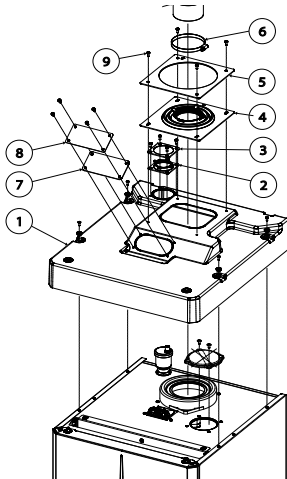

IPX5D COVER KIT
CODE: 3.033671

Models:
VICTRIX PRO V2 100 EU
VICTRIX PRO V2 120 EU

IPX5D COVER KIT
CODE: 3.033672

Model:
VICTRIX PRO V2 150 EU

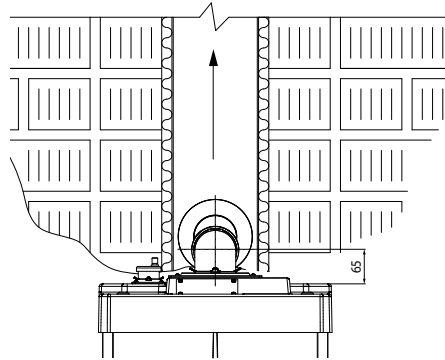

IPX5D COVER KIT

CODE: 3.033670

Models:

VICTRIX PRO V2 35 EU
VICTRIX PRO V2 55 EU
VICTRIX PRO V2 60 EU
VICTRIX PRO V2 68 EU
VICTRIX PRO V2 80 EU

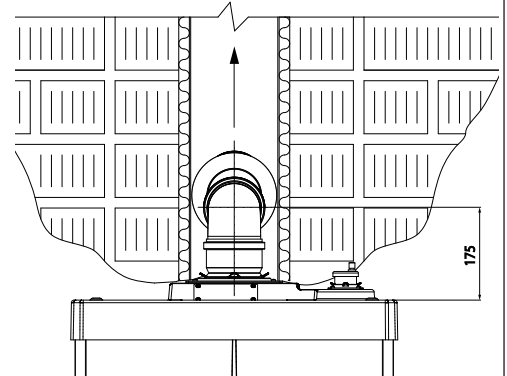
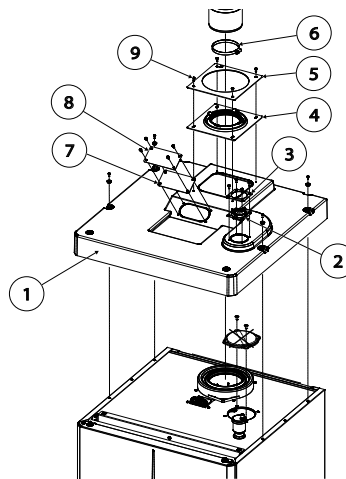

Key:

- 1 - Thermoformed cover
- 2 - Air vent gasket
- 3 - Air vent gasket locking plate
- 4 - Flue exhaust gasket
- 5 - Flue exhaust gasket locking flange
- 6 - Stainless steel clip for flue gas seal
- 7 - Manhole seal
- 8 - Sheet metal manhole cover
- 9 - Self-threading screws

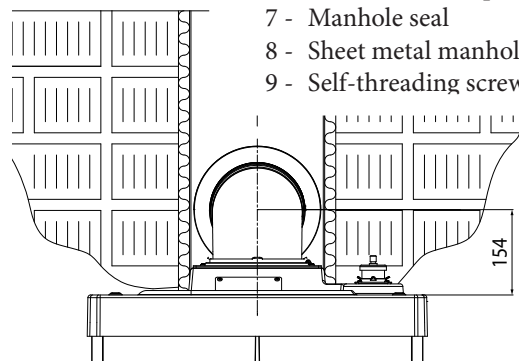
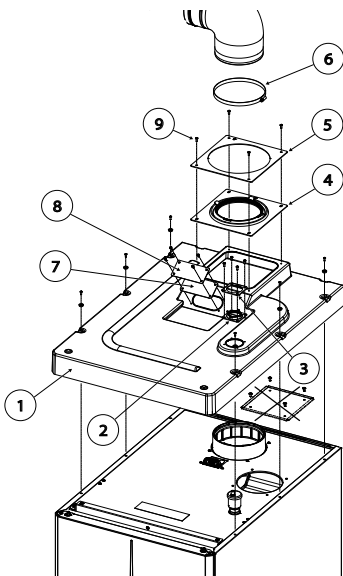

IPX5D COVER KIT

CODE: 3.033689

Model:

VICTRIX PRO V2 180 EU

24.10

FAN HEAD AND MAXIMUM LENGTHS

The maximum head of the fan refers to the flue outlet above the generator. Dimensioning of a chimney/ducted pipe can be carried out in positive or negative pressure. To calculate the length of the flue, simply add the corresponding "length equivalent to 1 m of pipe" value for each component to be

used until the maximum allowed length for each product is reached. These data are provided in the specific technical documentation supplied with each "Use and maintenance booklet".

VICTRIX PRO V2 35 EU	TYPICAL INSTALLATION:	MAXIMUM LENGTH:
Head in variable flue gas outlet from 1 to 90 (Pa)		--
Concentric Ø 80/125 (mm)	C13 (horizontal+curve) C33 (vertical)	15 (m)
Split Ø 80/80 (mm)	C43 - C53 - C83 (split)	30 (m)
	B23 - B23p - B53 - B53p	30 (m) - with Clapet valve 15 (m)
Flue exhaust only Ø 80 (mm) C5	C53 (A: 1c+1m - S: 1c+1m+1c)	30 (m)
Flue exhaust only Ø 80 (mm) flex	C53 (A: 1c+1m - S: 1c+1m+1c+ad.)	12 (m)

VICTRIX PRO V2 55 EU	TYPICAL INSTALLATION:	MAXIMUM LENGTH:
Head in variable flue gas outlet from 2 to 190 (Pa)		--
Concentric Ø 80/125 (mm)	C13 (horizontal+curve) C33 (vertical)	15 (m)
Split Ø 80/80 (mm)	C43 - C53 - C83 (split)	30 (m)
	B23 - B23p - B53 - B53p	25 (m) - with Clapet valve 15 (m)
Flue exhaust only Ø 80 (mm) C5	C53 (A: 1c+1m - S: 1c+1m+1c)	30 (m)
Flue exhaust only Ø 80 (mm) flex	C53 (A: 1c+1m - S: 1c+1m+1c+ad.)	12 (m)

VICTRIX PRO V2 60 - 68 - 80 EU	TYPICAL INSTALLATION:	MAXIMUM LENGTH:
Head in variable flue gas outlet from 3 to 295 (Pa)		--
Concentric Ø 80/125 (mm)	C13 (horizontal+curve) C33 (vertical)	10 (m)
Split Ø 80/80 (mm)	C43 - C53 - C83 (split)	20 (m)
	B23 - B23p - B53 - B53p	20 (m) - with Clapet valve 10 (m)
Flue exhaust only Ø 80 (mm) C5	C53 (A: 1c+1m - S: 1c+1m+1c)	20 (m)
Flue exhaust only Ø 80 (mm) flex	C53 (A: 1c+1m - S: 1c+1m+1c+ad.)	8 (m)

VICTRIX PRO V2 100 EU	TYPICAL INSTALLATION:	MAXIMUM LENGTH:
Head in variable flue gas outlet from 3 to 230 (Pa)		--
Concentric Ø 110/160 (mm)	C13 (horizontal+curve) C33 (vertical)	10 (m)
Split Ø 100/100 (mm)	C43 - C53 - C83 (split)	25 (m)
	B23 - B23p - B53 - B53p	20 (m) - with Clapet valve 10 (m)
Flue exhaust only Ø 100 (mm) C5	C53 (A: 1c+1m - S: 1c+1m+1c)	20 (m)

VICTRIX PRO V2 120 EU	TYPICAL INSTALLATION:	MAXIMUM LENGTH:
Head in variable flue gas outlet from 4 to 360 (Pa)		--
Concentric Ø 110/160 (mm)	C13 (horizontal+curve) C33 (vertical)	10 (m)
Split Ø 100/100 (mm)	C43 - C53 - C83 (split)	25 (m)
	B23 - B23p - B53 - B53p	20 (m) - with Clapet valve 9 (m)
Flue exhaust only Ø 100 (mm) C5	C53 (A: 1c+1m - S: 1c+1m+1c)	20 (m)

VICTRIX PRO V2 EU

VICTRIX PRO V2 150 EU	TYPICAL INSTALLATION:	MAXIMUM LENGTH:
Head in variable flue gas outlet from 16 to 350 (Pa)		--
Concentric Ø 110/160 (mm)	C13 (horizontal+curve) C33 (vertical)	5 (m)
Split Ø 100/100 (mm)	C43 - C53 - C83 (split)	20 (m)
	B23 - B23p - B53 - B53p	10 (m) - with Clapet valve 3 (m)
Flue exhaust only Ø 100 (mm) C5	C53 (A: 1c+1m - S: 1c+1m+1c)	10 (m)

VICTRIX PRO V2 180 EU	TYPICAL INSTALLATION:	MAXIMUM LENGTH:
Head in variable flue gas outlet from 1 to 30 (Pa)		--
Split Ø 160/160 (mm)	C43 - C53 - C83 (split)	8 (m)
	B23 - B23p	8 (m)
Flue exhaust only Ø 160 (mm) C5	C53 (A: 1c+1m - S: 1c+1m+1c)	8 (m)

24.11

FLEXIBLE DUCTING SYSTEM Ø 80 (OPTIONAL)

VICTRIX PRO V2 35 - 55 - 60 - 68 - 80 EU

The Immergas Ø 80 mm system for flexible ducting of existing chimneys is made up from a series of components, identified as individual kits, which can be assembled depending on the specific installation requirements. This system is supplied in a configuration that envisions an ascending 87° input bend, then continuing vertically with the Ø 80 flexible hose and the exhaust terminal. The ducted tube is inspected at the mouth of the boiler, via the relevant hatch.

The kit is made up from a 12 m flexible hose. If the hose is too short it can be joined to other pieces via the relevant adapters. A centring spacer must however be inserted every now and again, which via extendible fins, allows the pipe to stay in the centre of the flue.

The maximum length for this ducting system is:

VICTRIX PRO V2 35 EU = 12 m

VICTRIX PRO V2 55 EU = 12 m

VICTRIX PRO V2 60 - 68 - 80 EU = 8 m

This length is obtained by considering:

- 1 Ø 80 mm 90° bend for connection to the boiler (intake);
- 1 m of Ø 80 mm pipe (in intake) with grid;
- 1 Ø 80 mm 90° bend for connection to the boiler (exhaust);
- 1 m pipe Ø 80 mm (in exhaust);
- the Ø 80 mm bend support;
- the vertical terminal kit for ducting Ø 80/125.

It is important to highlight that:

- in all cases it is a system to which a **unique appliance can be coupled**;
- the system **can only be coupled with condensing appliances**.

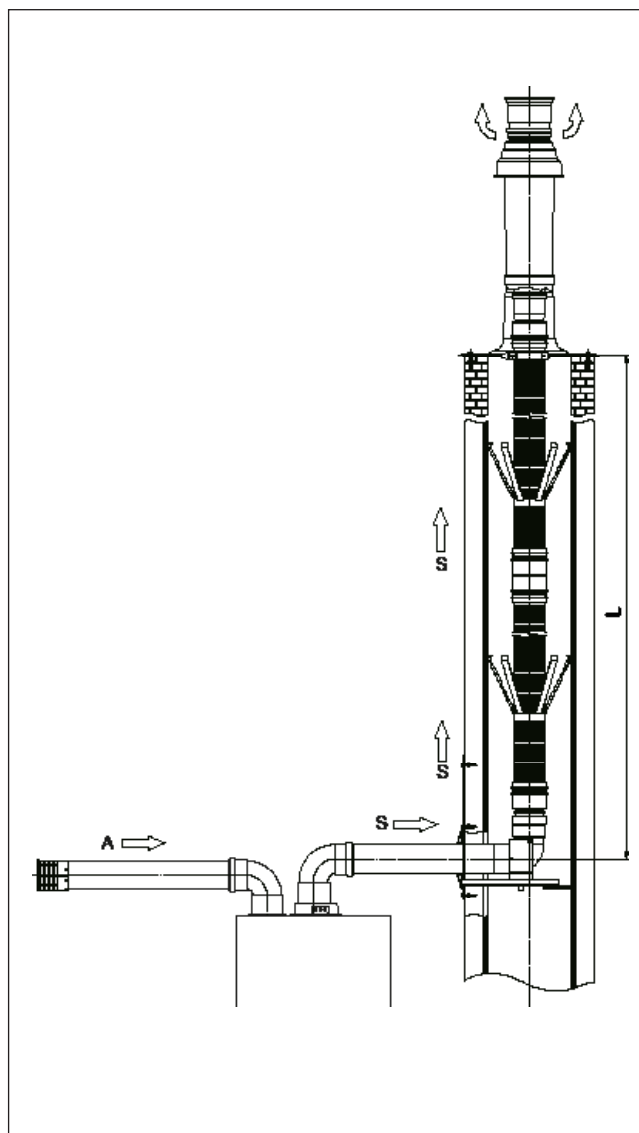

VICTRIX PRO V2 35 - 55 - 60 - 68 - 80 EU

25 FLUE EXHAUST MANIFOLD KIT Ø 160 WITH VICTRIX PRO V2 35 - 55 - 60 - 68 - 80 EU FLUE ADJUSTING DEVICE (CODE: 3.034257)

THE KIT INCLUDES:

- 1 - 1st Ø 80 Module connection
- 2 - 2nd Ø 80 Module connection
- 3 - Clapet valve Ø 80
- 4 - 1st Ø 160 Module manifold
- 5 - 2nd Ø 160 Module manifold
- 6 - Manifold for initial section Ø 160
- 7 - Drain trap unit

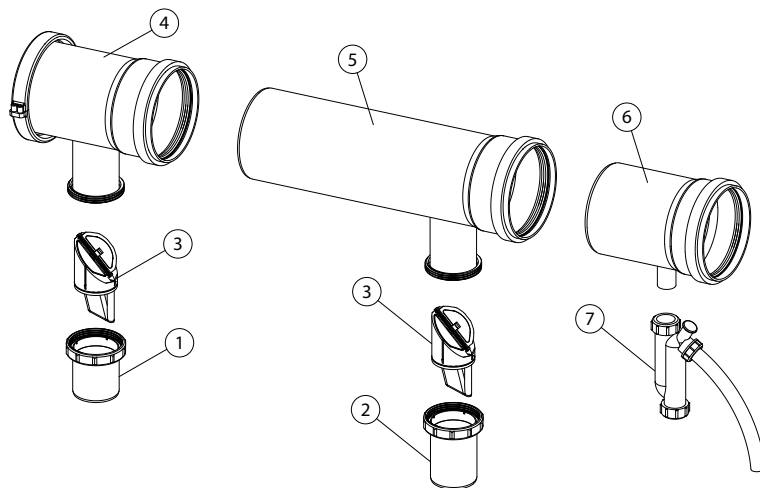

25.1 FLUE EXHAUST MANIFOLD KIT Ø 160 WITH FLUE ADJUSTING DEVICE TO EXPAND VICTRIX PRO V2 35 - 55 - 60 - 68 - 80 EU (CODE: 3.034258)

THE KIT INCLUDES:

- 3 - Clapet valve Ø 80
- 5 - Additional Ø 160 module manifold
- 8 - Additional Ø 80 module manifold

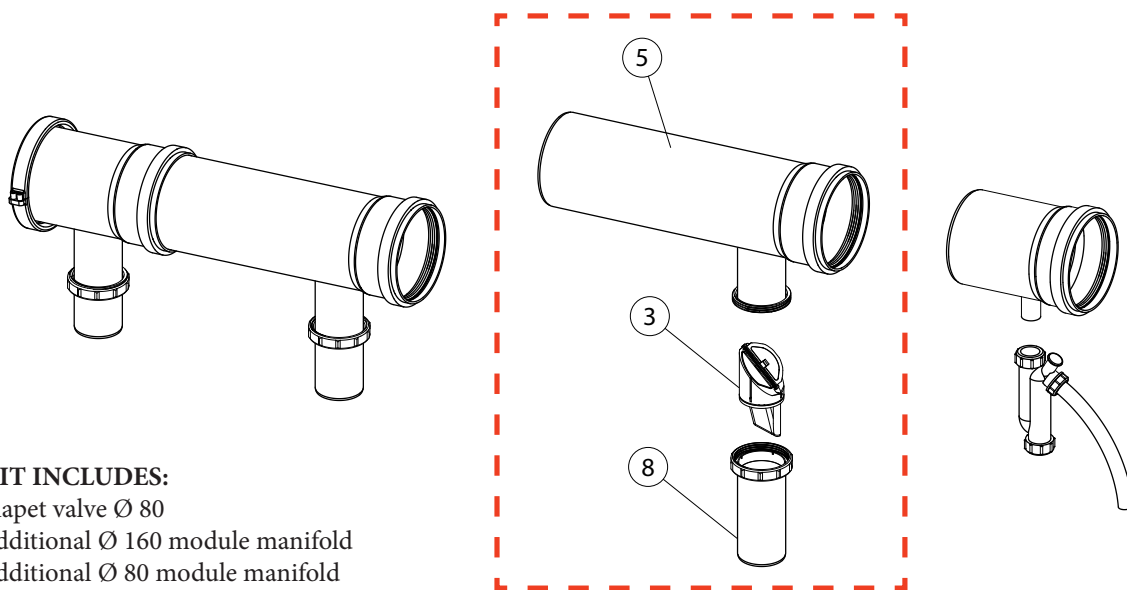

Modules	160 Ø Flue manifold kit code: 3.034257	160 Ø Flue manifold kit for expansion code 3.034258
2 VICTRIX PRO 35-55-60-68-80 V2	N° 1	--
3 VICTRIX PRO 35-55-60-68-80 V2	N° 1	N° 1
4 VICTRIX PRO 35-55-60-68-80 V2	N° 1	N° 2
5 VICTRIX PRO 35-55-60-68-80 V2	N° 1	N° 3

VICTRIX PRO V2 100 - 120 - 150 EU

25.2 FLUE EXHAUST MANIFOLD KIT Ø 200 WITH VICTRIX PRO V2 100 - 120 - 150 EU FLUE ADJUSTING DEVICE (CODE: 3.034259)

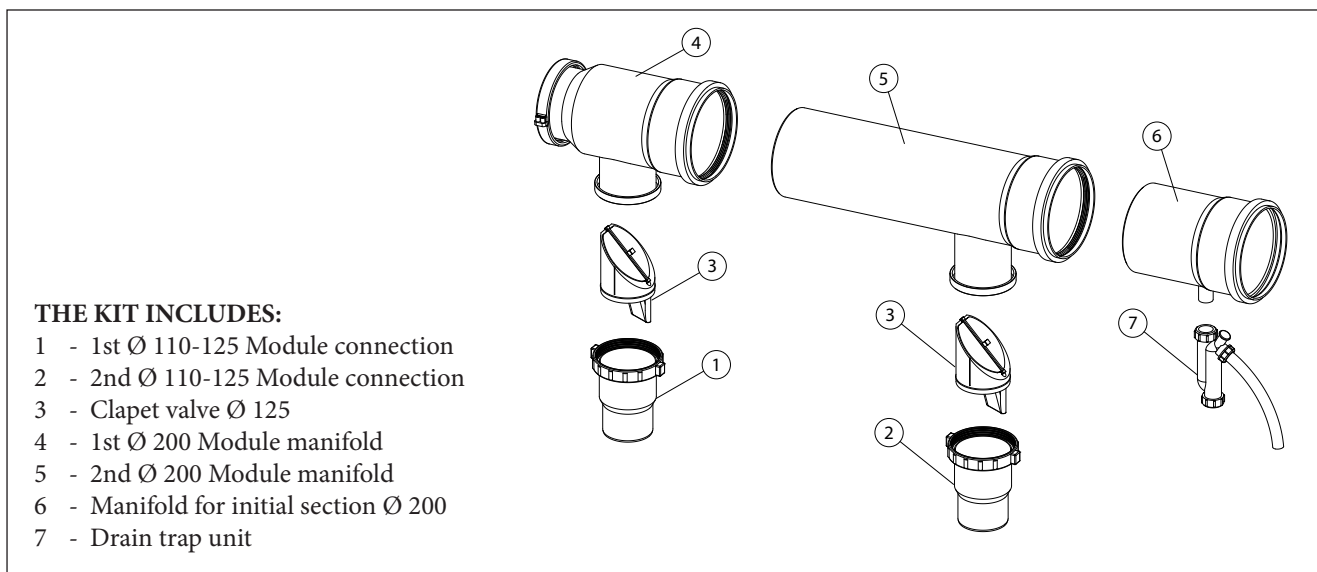

25.3 FLUE EXHAUST MANIFOLD KIT Ø 200 WITH FLUE ADJUSTING DEVICE TO EXPAND VICTRIX PRO V2 100 - 120 - 150 EU (CODE: 3.034260)

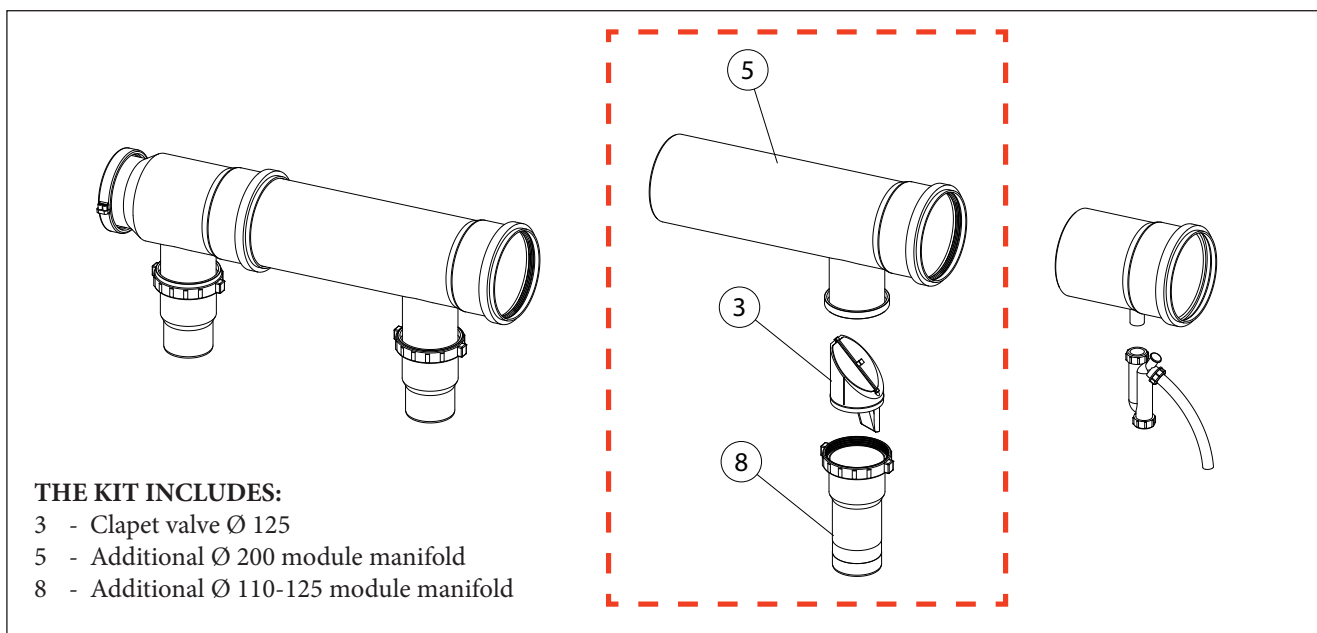

Modules	200 Ø Flue manifold kit code: 3.034259	200 Ø Flue manifold kit for expansion code: 3.034260
2 VICTRIX PRO V2 100-120-150 EU	N° 1	--
3 VICTRIX PRO V2 100-120-150 EU	N° 1	N° 1
4 VICTRIX PRO V2 100-120 EU	N° 1	N° 2
5 VICTRIX PRO V2 100-120 EU	N° 1	N° 3

VICTRIX PRO V2 100 - 120 - 150 EU

25.4 FLUE EXHAUST MANIFOLD KIT Ø 250 WITH FLUE ADJUSTING DEVICES TO EXPAND 4TH ICTRIX PRO V2 150 EU (CODE: 3.034261)

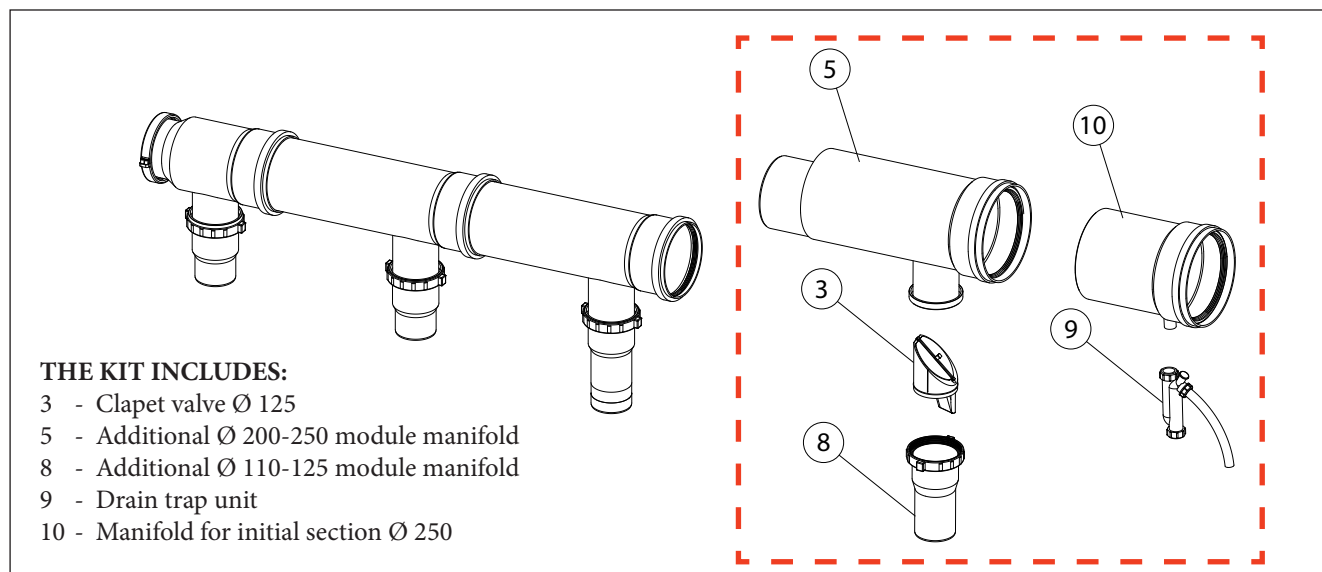

25.5 FLUE EXHAUST MANIFOLD KIT Ø 250 WITH FLUE ADJUSTING DEVICES TO EXPAND 5TH VICTRIX PRO V2 150 EU (CODE: 3.034262)

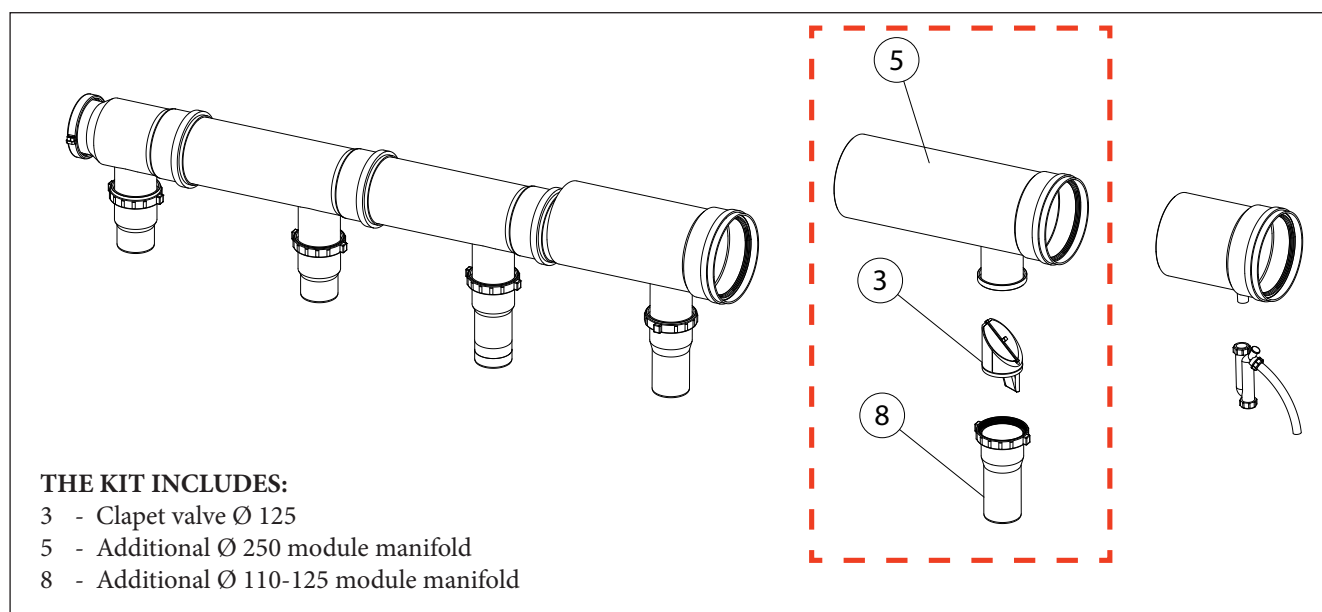

Modules	Flue manifold kit Ø 200 code: 3.034259	Flue manifold kit Ø 200 extension code: 3.034260	Flue manifold kit Ø 250 extension code: 3.034261	Flue manifold kit Ø 250 extension code: 3.034262
2 VICTRIX PRO V2 150 EU	N° 1	--	--	--
3 VICTRIX PRO V2 150 EU	N° 1	N° 1	--	--
4 VICTRIX PRO V2 150 EU	N° 1	N° 1	N° 1	--
5 VICTRIX PRO V2 150 EU	N° 1	N° 1	N° 1	N° 1

VICTRIX PRO V2 EU

25.6 RESIDUAL HEAD AVAILABLE ON CHIMNEY OPENING

The chimney/ducted pipe which collects the flue gas coming from the flue manifold, is sized under pressure or vacuum. If you wish to operate with a pressurised chimney/ducted pipe, the value of the residual head at the ends of the set - shown

in the table - represents the maximum head loss of the flue system to guarantee operation of the modules in cascade in dynamic mode.

		Number of modules in set configuration:	N° 2	N° 3	N° 4	N° 5
VICTRIX PRO V2 35 EU	Nominal heat input (kW)		69,8	104,7	139,6	174,5
	Flue diameter (mm)		Ø 160			
	Residual head at the ends of the cascade (Pa)		13,0	28,0	50,0	78,0
	Parameter "P26" Min Fan Speed (rpm)		1700			
VICTRIX PRO V2 55 EU	Nominal heat input (kW)		102,0	153,0	204,0	255,0
	Flue diameter (mm)		Ø 160			
	Residual head at the ends of the cascade (Pa)		27,0	61,0	109,0	170,0
	Parameter "P26" Min Fan Speed (rpm)		1700			
VICTRIX PRO V2 60 EU	Nominal heat input (kW)		102,0	153,0	204,0	255,0
	Flue diameter (mm)		Ø 160			
	Residual head at the ends of the cascade (Pa)		27,0	61,0	109,0	170,0
	Parameter "P26" Min Fan Speed (rpm)		1700			
VICTRIX PRO V2 68 EU	Nominal heat input (kW)		102,0	153,0	204,0	255,0
	Flue diameter (mm)		Ø 160			
	Residual head at the ends of the cascade (Pa)		27,0	61,0	109,0	170,0
	Parameter "P26" Min Fan Speed (rpm)		1700			
VICTRIX PRO V2 80 EU	Nominal heat input (kW)		150,0	225,0	300,0	375,0
	Flue diameter (mm)		Ø 160			
	Residual head at the ends of the cascade (Pa)		23,0	52,0	93,0	145,0
	Parameter "P26" Min Fan Speed (rpm)		1700			
VICTRIX PRO V2 100 EU	Nominal heat input (kW)		186,0	279,0	372,0	465,0
	Flue diameter (mm)		Ø 200			
	Residual head at the ends of the cascade (Pa)		11,5	26,0	45,0	71,0
	Parameter "P26" Min Fan Speed (rpm)		1500			
VICTRIX PRO V2 120 EU	Nominal heat input (kW)		229,0	343,5	458,0	572,5
	Flue diameter (mm)		Ø 200			
	Residual head at the ends of the cascade (Pa)		18,0	40,0	72,0	112,0
	Parameter "P26" Min Fan Speed (rpm)		1500			
VICTRIX PRO V2 150 EU	Nominal heat input (kW)		282,0	423,0	564,0	705,0
	Flue diameter (mm)		Ø 200		Ø 250	
	Residual head at the ends of the cascade (Pa)		18,0	40,0	70,0	110,0
	Parameter "P26" Min Fan Speed (rpm)		1850*			

KEY:

- BK - Black
- BL - Blue
- BR - Brown
- CY - Cyan
- G - Green
- GY - Grey
- G/Y - Yellow/Green
- W/BK - White/Black
- OR - Orange
- P - Purple
- PK - Pink
- R - Red
- W - White
- Y - Yellow

- 1 - 230 Vac 50Hz Power supply
- 2 - Testing/iXTool (Busmicrom)
- 3 - External reset (Optional)
- 4 - Bus openTherm 1
- 5 - Bus openTherm 2
- 6 - 0-10 V analogue input
- 7 - Modbus (Slave)
- 8 - Modbus (Master)

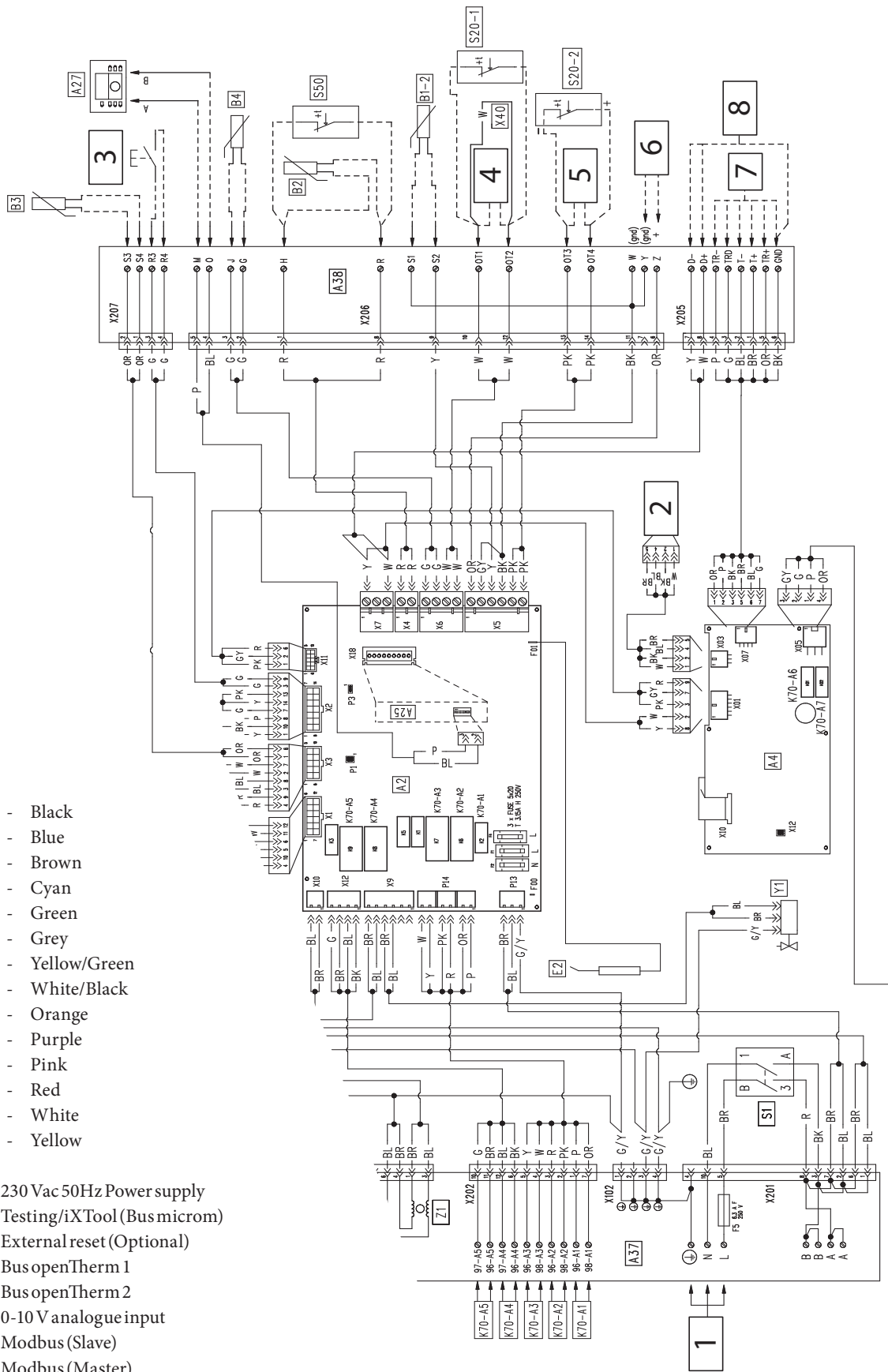

VICTRIX PRO V2 EU

KEY:	
A2	- Circuitboard
A4	- Displayboard
A25	- CLIP-IN (Optional)
A27	- Cascade and zone regulator;
A37	- Connection sheet (loads)
A38	- Connection card (signals)
B1-2	- System flow side probe (optional)
B2	- DHW probe (optional)
B3	- Low temperature flow probe (optional)
B4	- External probe (Optional)
E2	- Detection electrode
F5	- Phase fuse
F1	- Phase fuse
F2	- Neutral fuse
F4:	- Phase fuse
K1	- Gasvalve relay (Line)
K5	- Gasvalve relay (Neutral)
K3	- Igniter relay
K70	- Multifunction relay
P1	- SW update (iXTool)
P3	- Pin (1&2) Communication jumper (Do not remove)
S1	- Mainswitch
S20-1	- Zone 1 room thermostat (optional)
S20-2	- Zone 2 room thermostat (optional)
S50	- DHW Thermostat/Contact
X12	- Software Update (iXTool)
X40	- Room thermostat jumper
Y1	- Gasvalve
Z1	- Antijamming filter

N.B.: The new electronics of VICTRIX PRO V2 EU can now control up to 15 thermal modules in simple cascade! It can also completely independently manage up to 2 zones of the thermal system (1 direct and 1 mixed, if any) and 1 DHW production circuit.

Maximum loads on Relays of boards A2 and A4

Multifunction relay	Voltage	Current	cosφ	
K70-A1 K70-A2 K70-A3 K70-A4 K70-A5	230 Vac	<0.1 A	≥0,6	From factory settings, K70 relays do not perform any functions. Insert an optional external relay to drive each load.
K70-A6 K70-A7	Potential-free contact (230 Vac max)	<0.1 A	≥0,6	

- Remove X40 bridge in case of connection:

- Cascade and zone regulator;
- 0-10V signal;
- BMS;
- BUSOT;
- some types of central heating demand.

- For low-temperature zones, insert a safety thermostat in series with the relative zone pump.

- Make sure that the OpenTherm thermostat is compatible with the appliance.

- If the 0-10V input is enabled by means of the specific parameter, insert a 4,7 kohm resistance on terminals Y and Z.

ELECTRICAL CONNECTIONS (SIGNALS)

Components	Cable gauge (mm ²)		Maximum length (m)
	Minimum	Maximum	
* B1-2 * B2 * B3 * S50 * 0-10V	0.5	1.5	25 (2x25)
* B4 * S20-1 * S20-2 * OpenTherm	0.5	1.5	50 (2x50)
* External reset	0.5	1.5	10 (2x10)
* A27	J-Y(ST)Y 2x0.6		50 (2x50)

26.1 WIRING DIAGRAM: 3-WAY DHW VALVE- HYDRAULIC SEPARATOR - - DIRECT ZONE 1 - MIXED ZONE 2

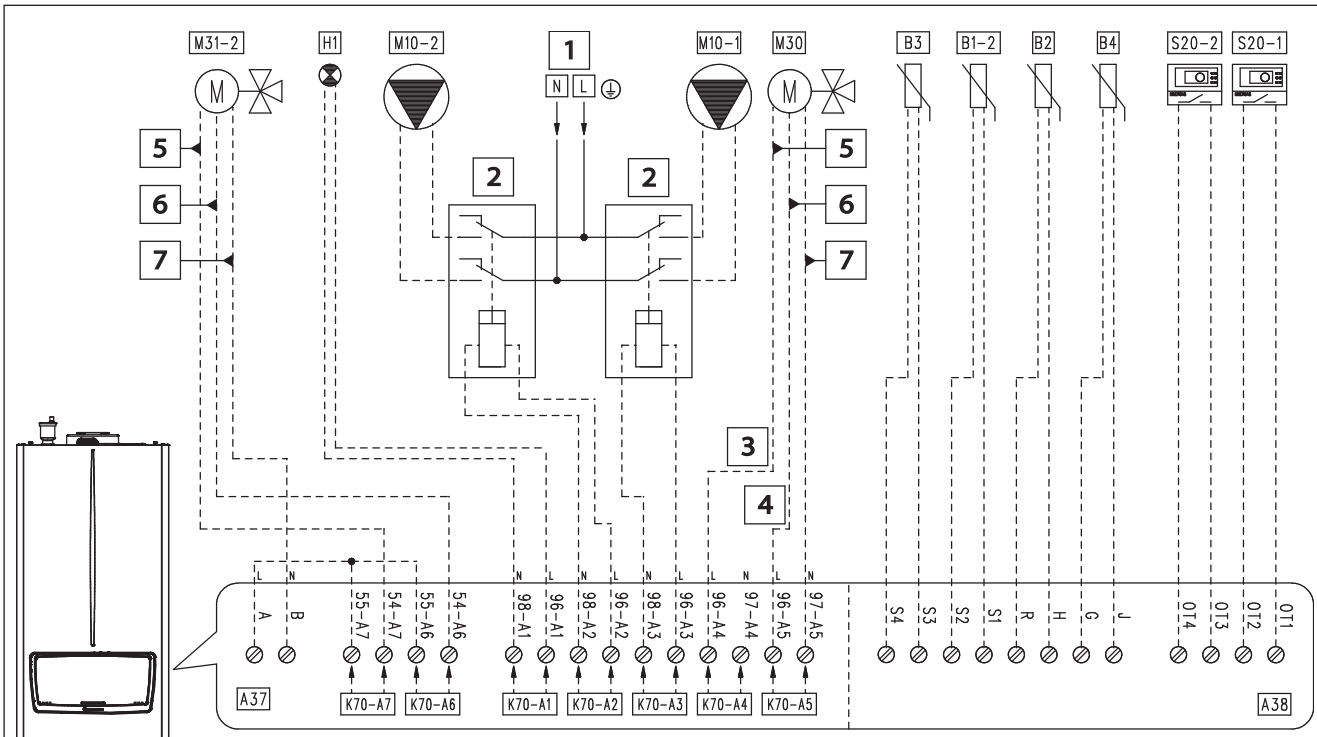

"HYDRAULIC SETTINGS" parameter configuration table (Technician menu)	
Parameter/menu name	Setting
"Relay settings" submenu:	
- K70-A1	- Error
- K70-A2	- Zone 2 pump
- K70-A3	- Zone 1 pump
- K70-A4	- 3-way valve DHW
- K70-A5	- 3-way valve CH
- K70-A6	- Mixing valve: opens
- K70-A7	- Mixing valve: closes
System pump configuration	
- System sensor	- C.H. mode
"Mixed zone" submenu:	
- Mixed zone selection	- 2
- Valve time	- 150
- Type of heating request	- Climatic curve outside temperature and room thermostat
- DHW request type	- Sensor
- Parallel mode	- Disabled
"3-way valve" submenu:	
- 3-way valve selection	- Motorised
- 3-way valve stroke time	- 12
- Default position	- Central heating
Note: If you want to use zone 1 as a mixed zone and zone 2 as a direct zone, you have to set the "Select mixed zone" parameter to "1", and then set the setpoints of zone 1 and zone 2 correctly.	

- Key:
- A37 - Connection sheet (loads)
 - A38 - Connection card (signals)
 - B1-2 - System flow probe (NTC) (optional)
 - B2 - Domestic hot water probe (NTC) (optional)
 - B3 - Flow probe (Low temperature) (NTC) (optional)
 - B4 - External probe (NTC) (optional)
 - H1 - "ERROR" indicator light (230 Vac) (optional)
 - M10-1 - Zone 1 circulator pump (optional)
 - M10-2 - Zone 2 circulator pump (optional)
 - M30 - 3-way valve (optional)
 - M31-2 - Mixing valve - zone 2 (optional)
 - S20-1 - Zone 1 room thermostat (optional)
 - S20-2 - Zone 2 room thermostat (optional)
 - 1 - 230 Vac - 50 Hz
 - 2 - External relay (optional) 230 vAC coil Max 0,1 A
 - 3 - Domestic hot water
 - 4 - Central heating
 - 5 - Close
 - 6 - Open
 - 7 - Common

VICTRIX PRO V2 EU

26.2 WIRING DIAGRAM: 3-WAY DHW VALVE- HYDRAULIC SEPARATOR - - MIXED CENTRAL HEATING ZONE 2

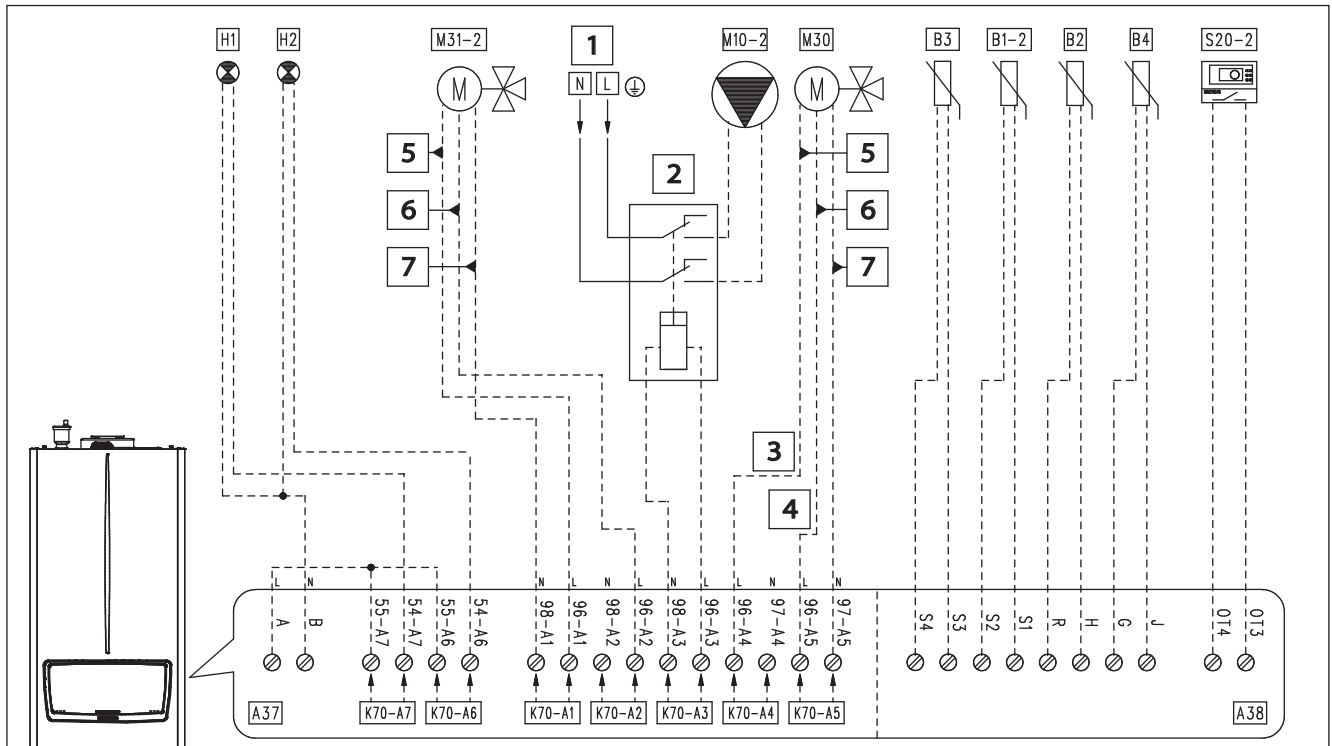

"HYDRAULIC SETTINGS"
parameter configuration table (Technician menu)

Parameter/menu name	Setting
"Relay settings" submenu:	
- K70-A1	- Mixing valve: closes
- K70-A2	- Mixing valve: opens
- K70-A3	- Zone 2 pump
- K70-A4	- 3-way valve DHW
- K70-A5	- 3-way valve CH
- K70-A6	- Burner on
- K70-A7	- Error
System pump configuration	
- System sensor	- C.H. mode
"Mixed zone" submenu:	
- Mixed zone selection	- 2
- Valve time	- 150
- Type of heating request	- Climatic curve outside temperature and room thermostat
- DHW request type	- Sensor
- Parallel mode	- Disabled
"3-way valve" submenu:	
- 3-way valve selection	- Motorised
- 3-way valve stroke time	- 12
- Default position	- Central heating
Note: If you want to use zone 1 as a mixed zone, set the parameter "Select mixed zone" to "1", the parameter "K70-A3" as "Zone 1 pump", connect the room thermostat to the screw terminals "OT1" and "OT2" and set the setpoints of zone 1 correctly.	

Key:

- A37 - Connection sheet (loads)
- A38 - Connection card (signals)
- B1-2 - System flow probe (NTC) (optional)
- B2 - Domestic hot water probe (NTC) (optional)
- B3 - Flow probe (Low temperature) (NTC) (optional)
- B4 - External probe (NTC) (optional)
- H1 - "ERROR" indicator light (230 Vac) (optional)
- H2 - "Burner on" indicator light (230 Vac) (optional)
- M10-2 - Zone 2 circulator pump (optional)
- M30 - 3-way valve (optional)
- M31-2 - Mixing valve - zone 2 (optional)
- S20-2 - Zone 2 room thermostat (optional)
- 1 - 230 Vac - 50 Hz
- 2 - External relay (optional) 230 vAC coil Max 0,1 A
- 3 - Domestic hot water
- 4 - Central heating
- 5 - Close
- 6 - Open
- 7 - Common

26.3

**WIRING DIAGRAM: 3-WAY DHW VALVE-
- MIXED CENTRAL HEATING ZONE 2**

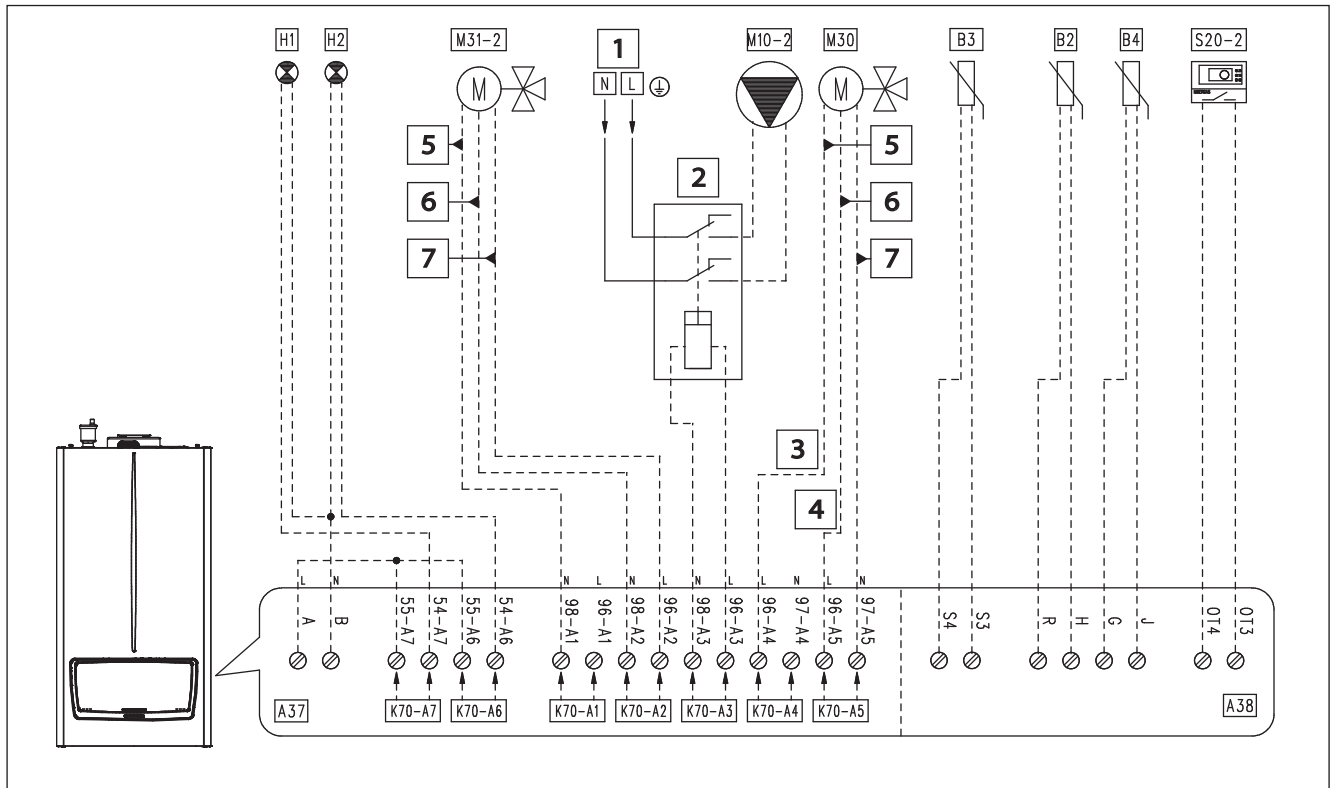

"HYDRAULIC SETTINGS" parameter configuration table (Technician menu)	
Parameter/menu name	Setting
"Relay settings" submenu:	
- K70-A1	- Mixing valve: closes
- K70-A2	- Mixing valve: opens
- K70-A3	- Zone 2 pump
- K70-A4	- 3-way valve DHW
- K70-A5	- 3-way valve CH
- K70-A6	- Burner on
- K70-A7	- Error
System pump configuration	- Not used
- System sensor	- Not used
"Mixed zone" submenu:	
- Mixed zone selection	- 2
- Valve time	- 150
- Type of heating request	- Climatic curve outside temperature and room thermostat
- DHW request type	- Sensor
- Parallel mode	- Disabled
"3-way valve" submenu:	
- 3-way valve selection	- Motorised
- 3-way valve stroke time	- 12
- Default position	- Central heating
Note: If you want to use zone 1 as a mixed zone, set the parameter "Select mixed zone" to "1", the parameter "K70-A3" as "Zone 1 pump", connect the room thermostat to the screw terminals "OT1" and "OT2" and set the setpoints of zone 1 correctly.	

- Key:
- A37 - Connection sheet (loads)
 - A38 - Connection card (signals)
 - B2 - Domestic hot water probe (NTC) (optional)
 - B3 - Flow probe (Low temperature) (NTC) (optional)
 - B4 - External probe (NTC) (optional)
 - H1 - "ERROR" indicator light (230 Vac) (optional)
 - H2 - "Burner on" indicator light (230 Vac) (optional)
 - M10-2 - Zone 2 circulator pump (optional)
 - M30 - 3-way valve (optional)
 - M31-2 - Mixing valve - zone 2 (optional)
 - S20-2 - Zone 2 room thermostat (optional)
 - 1 - 230 Vac - 50 Hz
 - 2 - External relay (optional) 230 vAC coil Max 0,1 A
 - 3 - Domestic hot water
 - 4 - Central heating
 - 5 - Close
 - 6 - Open
 - 7 - Common

VICTRIX PRO V2 EU

26.4 WIRING DIAGRAM: 3-WAY DHW VALVE- HYDRAULIC SEPARATOR - - 2 DIRECT HEATING ZONES

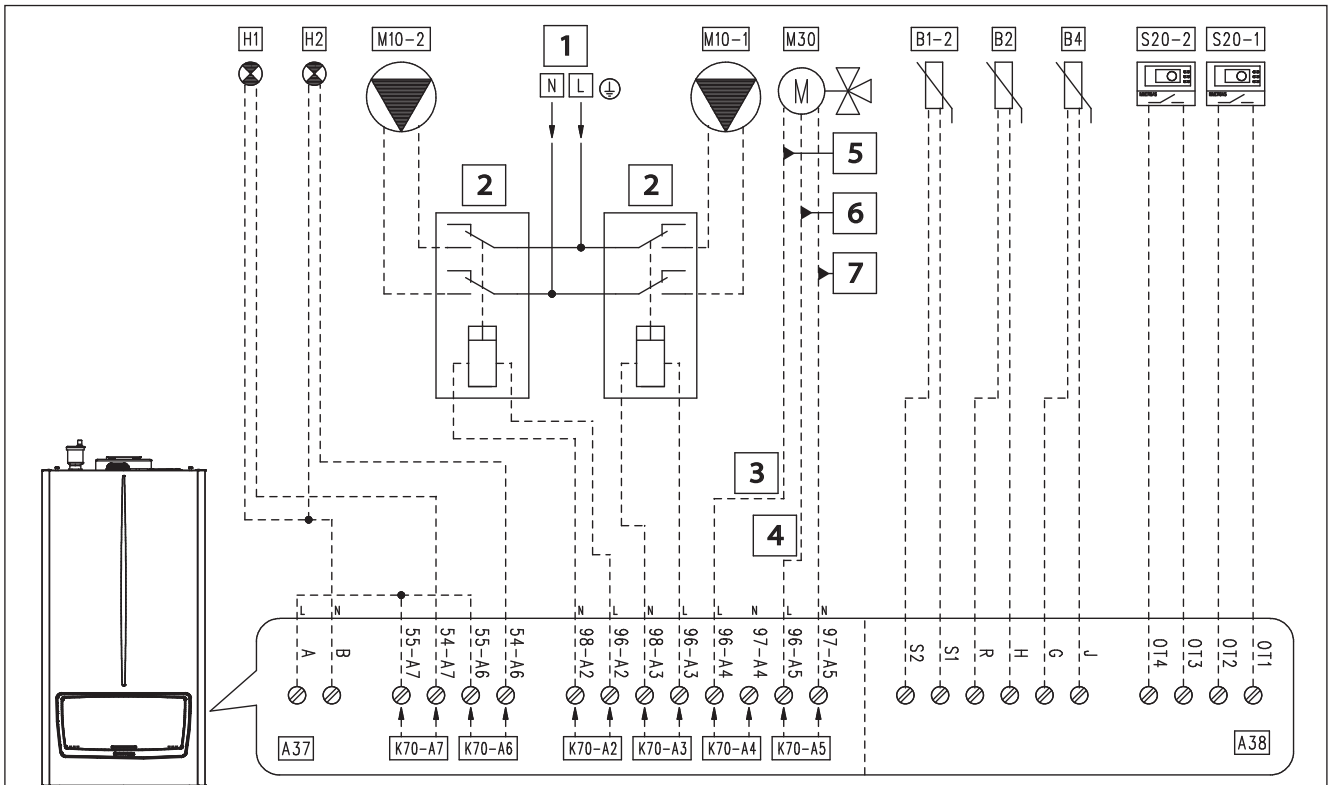

"HYDRAULIC SETTINGS" parameter configuration table (Technician menu)	
Parameter/menu name	Setting
"Relay settings" submenu:	
- K70-A1	- Relay not used
- K70-A2	- Zone 2 pump
- K70-A3	- Zone 1 pump
- K70-A4	- 3-way valve DHW
- K70-A5	- 3-way valve CH
- K70-A6	- Burner on
- K70-A7	- Error
System pump configuration	
- System sensor	- C.H. mode
- Type of heating request	- Climatic curve outside temperature and room thermostat
- DHW request type	- Sensor
- Parallel mode	- Disabled
"3-way valve" submenu:	
- 3-way valve selection	- Motorised
- 3-way valve stroke time	- 12
- Default position	- Central heating

Key:

- A37 - Connection sheet (loads)
- A38 - Connection card (signals)
- B1-2 - System flow probe (NTC) (optional)
- B2 - Domestic hot water probe (NTC) (optional)
- B4 - External probe (NTC) (optional)
- H1 - "ERROR" indicator light (230 Vac) (optional)
- H2 - "Burner on" indicator light (230 Vac) (optional)
- M10-1 - Zone 1 circulator pump (optional)
- M10-2 - Zone 2 circulator pump (optional)
- M30 - 3-way valve (optional)
- S20-1 - Zone 1 room thermostat (optional)
- S20-2 - Zone 2 room thermostat (optional)
- 1 - 230 Vac - 50 Hz
- 2 - External relay (optional) 230 vAC coil Max 0,1 A
- 3 - Domestic hot water
- 4 - Central heating
- 5 - Close
- 6 - Open
- 7 - Common

26.5 WIRING DIAGRAM: 3-WAY DHW VALVE- HYDRAULIC SEPARATOR - - DIRECT HEATING ZONE 1



Tabella configurazione parametri "IMPOSTAZIONI IDRAULICHE" (Menu tecnico)	
Nome del parametro/menu	Impostazione
"Relay settings" submenu:	
-K70-A1	-Error
-K70-A2	-Burner on
-K70-A3	-Zone 1 pump
-K70-A4	-3-way valve DHW
-K70-A5	-3-way valve CH
-K70-A6	-Relay not used
-K70-A7	-Relay not used
System pump configuration	
-System sensor	-C.H. mode
-Type of heating request	-Climatic curve outside temperature and room thermostat
-DHW request type	-Sensor
-Parallel mode	-Disabled
"3-way valve" submenu:	
-3-way valve selection	-Motorised
-3-way valve stroke time	-12
-Default position	-Central heating

- Key:
- A37 - Connection sheet (loads)
 - A38 - Connection card (signals)
 - B1-2 - System flow probe (NTC) (optional)
 - B2 - Domestic hot water probe (NTC) (optional)
 - B4 - External probe (NTC) (optional)
 - H1 - "ERROR" indicator light (230 Vac) (optional)
 - H2 - "Burner on" indicator light (230 Vac) (optional)
 - M10-1 - Zone 1 circulator pump (optional)
 - M30 - 3-way valve (optional)
 - S20-1 - Zone 1 room thermostat (optional)
 - 1 - 230 Vac - 50 Hz
 - 2 - External relay (optional) 230 vAC coil Max 0,1 A
 - 3 - Domestic hot water
 - 4 - Central heating
 - 5 - Close
 - 6 - Open
 - 7 - Common

VICTRIX PRO V2 EU

26.6

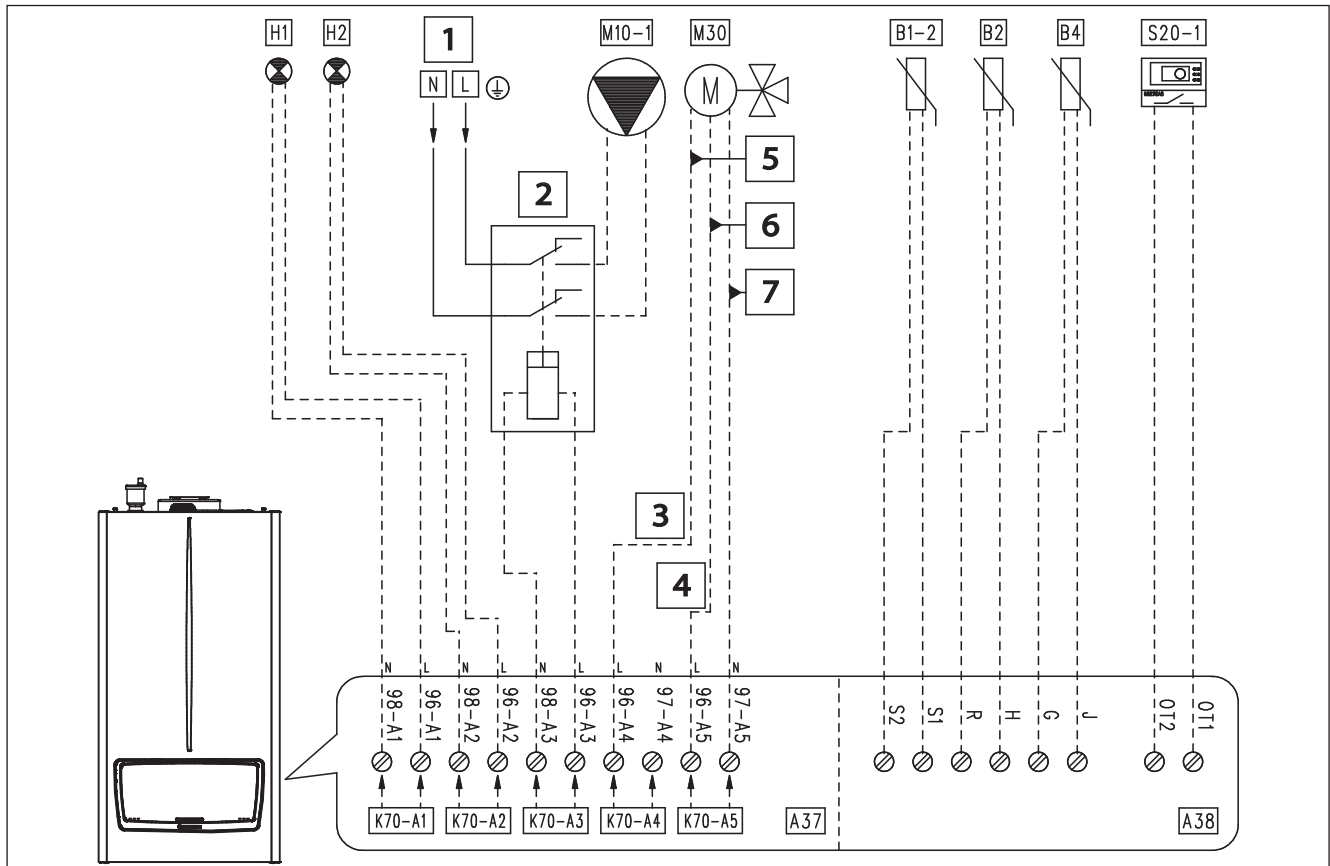
WIRING DIAGRAM: 3-WAY DHW VALVE-DHW THERMOSTAT - - ONE DIRECT HEATING ZONE



Tabella configurazione parametri "IMPOSTAZIONI IDRAULICHE" (Menu tecnico)	
Nome del parametro/menu	Impostazione
"Relay settings" submenu:	
- K70-A1	- Error
- K70-A2	- Burner on
- K70-A3	- Zone 1 pump
- K70-A4	- 3-way valve DHW
- K70-A5	- 3-way valve CH
- K70-A6	- Relay not used
- K70-A7	- Relay not used
System pump configuration	
- System sensor	- Not used
- Type of heating request	- Climatic curve outside temperature and room thermostat
- DHW request type	- Thermostat
- Parallel mode	- Disabled
"3-way valve" submenu:	
- 3-way valve selection	- Motorised
- 3-way valve stroke time	- 12
- Default position	- Central heating

Key:

- A37 - Connection sheet (loads)
- A38 - Connection card (signals)
- B4 - External probe (NTC) (optional)
- H1 - "ERROR" indicator light (230 Vac) (optional)
- H2 - "Burner on" indicator light (230 Vac) (optional)
- M30 - 3-way valve (optional)
- S20-1 - Zone 1 room thermostat (optional)
- S50 - DHW Thermostat
- 1 - Domestic hot water
- 2 - Central heating
- 3 - Close
- 4 - Open
- 5 - Common

**26.7 WIRING DIAGRAM: 3-WAY DHW VALVE- HYDRAULIC SEPARATOR -
- TWO DIRECT HEATING ZONES DOWNSTREAM OF THE SYSTEM PUMP**

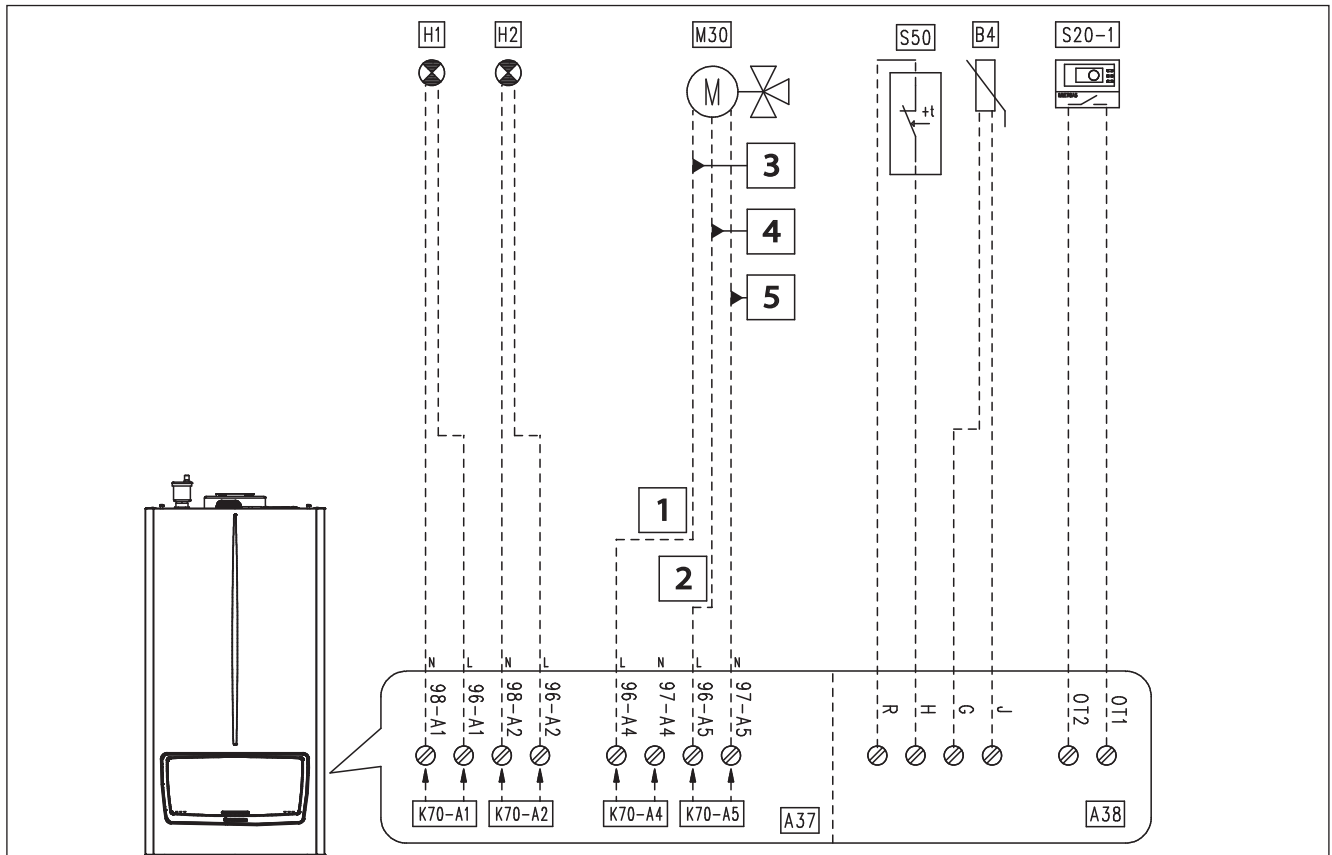
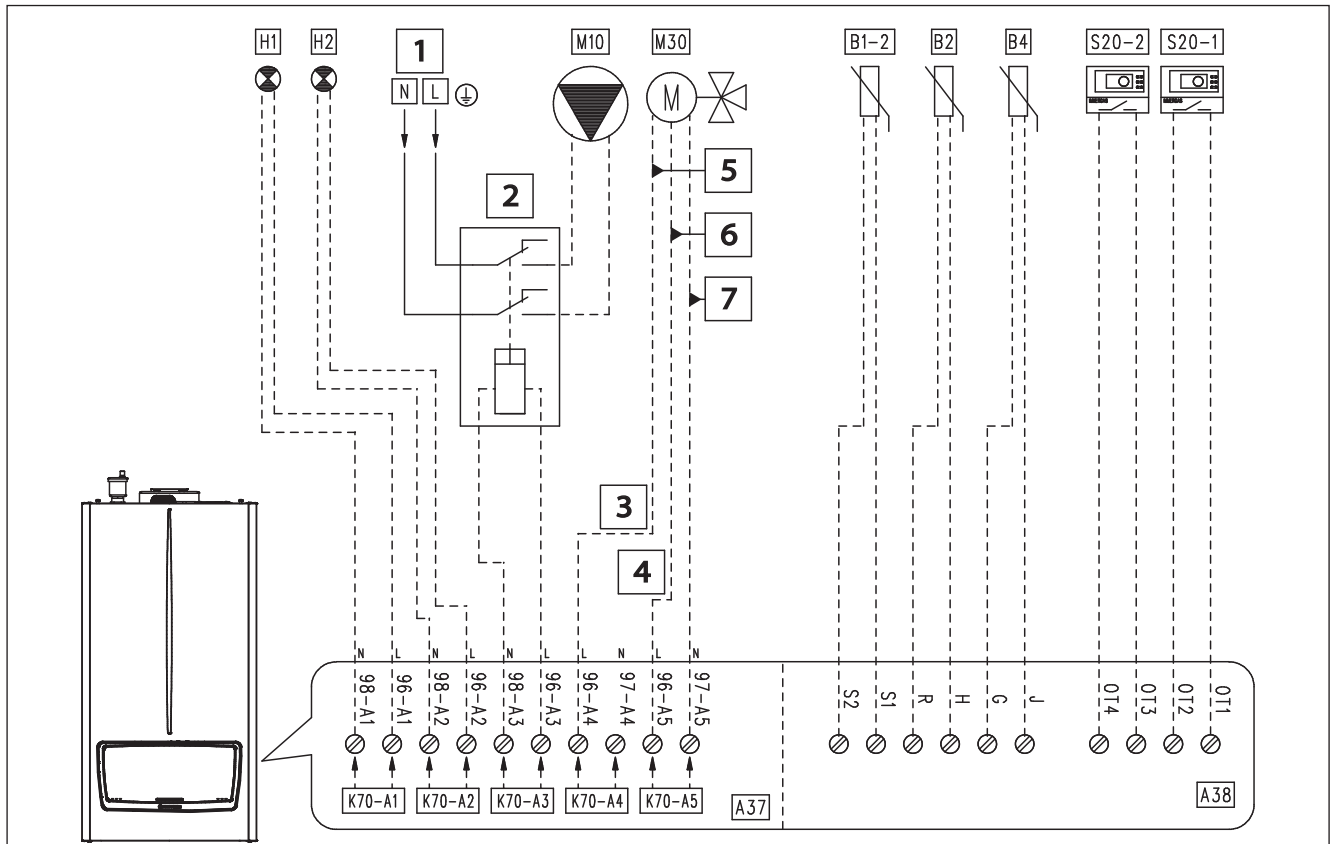

"HYDRAULIC SETTINGS" parameter configuration table (Technician menu)	
Parameter/menu name	Setting
"Relay settings" submenu:	
-K70-A1	-Error
-K70-A2	-Burner on
-K70-A3	-System pump
-K70-A4	-3-way valve DHW
-K70-A5	-3-way valve CH
-K70-A6	-Relay not used
-K70-A7	-Relay not used
System pump configuration	
-System sensor	-C.H. mode
-Type of heating request	- Climatic curve outside temperature and room thermostat
- DHW request type	- Sensor
- Parallel mode	- Disabled
"3-way valve" submenu:	
-3-way valve selection	- Motorised
-3-way valve stroke time	- 12
-Default position	- Central heating

- Key:
- A37 - Connection sheet (loads)
 - A38 - Connection card (signals)
 - B2 - Domestic hot water probe (NTC) (optional)
 - B4 - External probe (NTC) (optional)
 - H1 - "ERROR" indicator light (230 Vac) (optional)
 - H2 - "Burner on" indicator light (230 Vac) (optional)
 - M10 - System pump (optional)
 - M30 - 3-way valve (optional)
 - S20-1 - Zone 1 room thermostat (optional)
 - S20-2 - Zone 2 room thermostat (optional)
 - 1 - 230 Vac - 50 Hz
 - 2 - External relay (optional) 230 vAC coil Max 0,1 A
 - 3 - Domestic hot water
 - 4 - Central heating
 - 5 - Close
 - 6 - Open
 - 7 - Common

VICTRIX PRO V2 EU

26.8

WIRING DIAGRAM: 3-WAY DHW VALVE- - TWO DIRECT HEATING ZONES

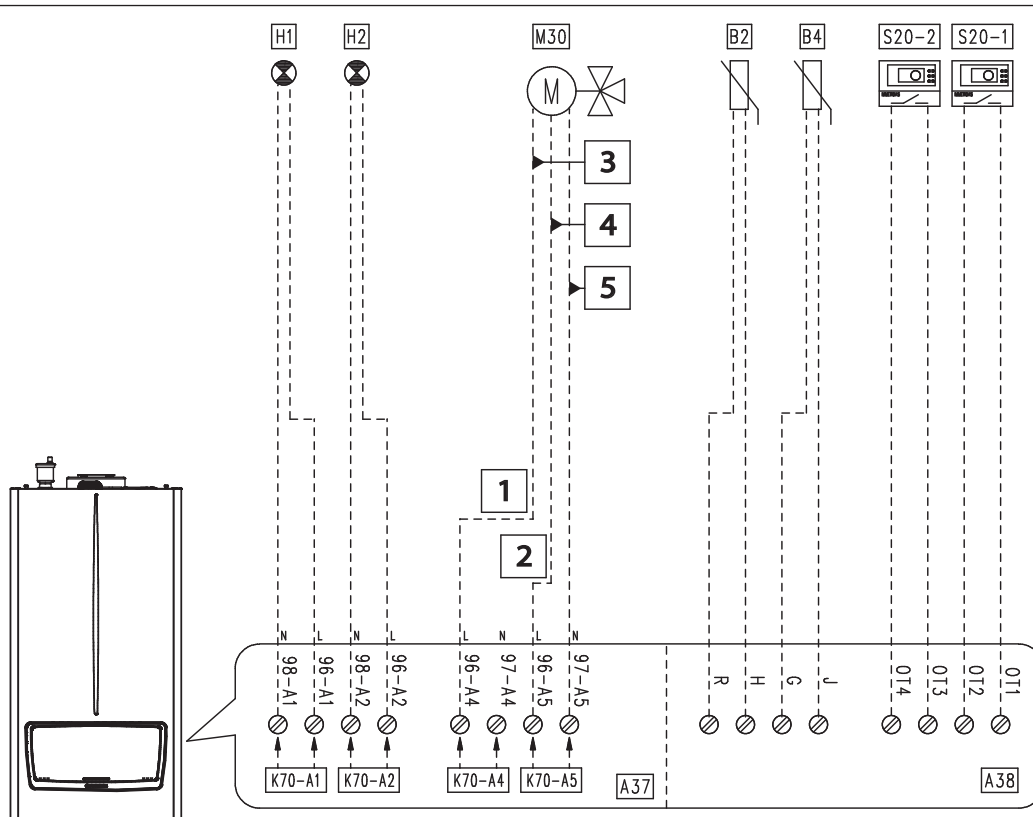

"HYDRAULIC SETTINGS" parameter configuration table ("Technician" menu)	
Parameter/menu name	Setting
"Relay settings" submenu:	
- K70-A1	- Error
- K70-A2	- Burner on
- K70-A3	- Relay not used
- K70-A4	- 3-way valve DHW
- K70-A5	- 3-way valve CH
- K70-A6	- Relay not used
- K70-A7	- Relay not used
System pump configuration	
- System sensor	- Not used
- Type of heating request	- Climatic curve outside temperature and room thermostat
- DHW request type	- Sensor
- Parallel mode	- Disabled
"3-way valve" submenu:	
- 3-way valve selection	- Motorised
- 3-way valve stroke time	- 12
- Default position	- Central heating
Note: The room thermostat of zone 1 uses the "Zone 1 CH setpoint"; the room thermostat of zone 2 uses the "Zone 2 CH setpoint" (in the case of a demand from both thermostats, the device uses the higher setpoint).	

Key:

- A37 - Connection sheet (loads)
- A38 - Connection card (signals)
- B2 - Domestic hot water probe (NTC) (optional)
- B4 - External probe (NTC) (optional)
- H1 - "ERROR" indicator light (230 Vac) (optional)
- H2 - "Burner on" indicator light (230 Vac) (optional)
- M30 - 3-way valve (optional)
- S20-1 - Zone 1 room thermostat (optional)
- S20-2 - Zone 2 room thermostat (optional)
- 1 - Domestic hot water
- 2 - Central heating
- 3 - Close
- 4 - Open
- 5 - Common

26.9

WIRING DIAGRAM: DHW ZONE - HYDRAULIC SEPARATOR - - DIRECT ZONE 1 - MIXED ZONE 2

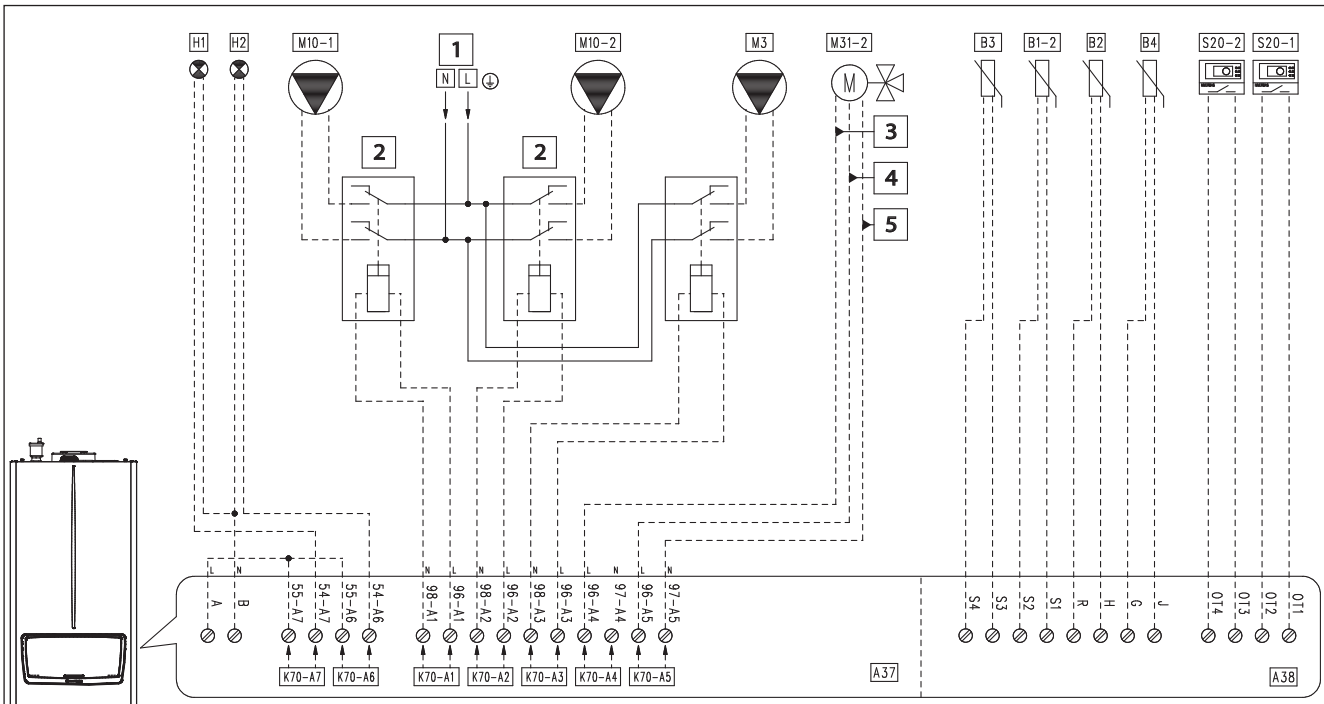

"HYDRAULIC SETTINGS" parameter configuration table (Technician menu)	
Parameter/menu name	Setting
"Relay settings" submenu:	
- K70-A1	- Zone 1 pump
- K70-A2	- Zone 2 pump
- K70-A3	- Domestic hot water pump
- K70-A4	- Mixing valve: closes
- K70-A5	- Mixing valve: opens
- K70-A6	- Burner on
- K70-A7	- Error
System pump configuration	
- System sensor	- C.H. + DHW mode
"Mixed zone" submenu:	
- Mixed zone selection	- 2
- Valve time	- 150
- Type of heating request	- Climatic curve outside temperature and room thermostat
- DHW request type	- Sensor
- Parallel mode	- Disabled

Key:

- A37 - Connection sheet (loads)
- A38 - Connection card (signals)
- B1-2 - System flow probe (NTC) (optional)
- B2 - Domestic hot water probe (NTC) (optional)
- B3 - Flow probe (Low temperature) (NTC) (optional)
- B4 - External probe (NTC) (optional)
- H1 - "ERROR" indicator light (230 Vac) (optional)
- H2 - "Burner on" indicator light (230 Vac) (optional)
- M3 - DHW pump (optional)
- M10-1 - Zone 1 circulator pump (optional)
- M10-2 - Zone 2 circulator pump (optional)
- M31-2 - Mixing valve - zone 2 (optional)
- S20-1 - Zone 1 room thermostat (optional)
- S20-2 - Zone 2 room thermostat (optional)
- 1 - 230 Vac - 50 Hz
- 2 - External relay (optional) 230 vAC coil Max 0,1 A
- 3 - Close
- 4 - Open
- 5 - Common

VICTRIX PRO V2 EU

26.10

WIRING DIAGRAM: DHW ZONE - HYDRAULIC SEPARATOR - - ZONE 1, MIXED

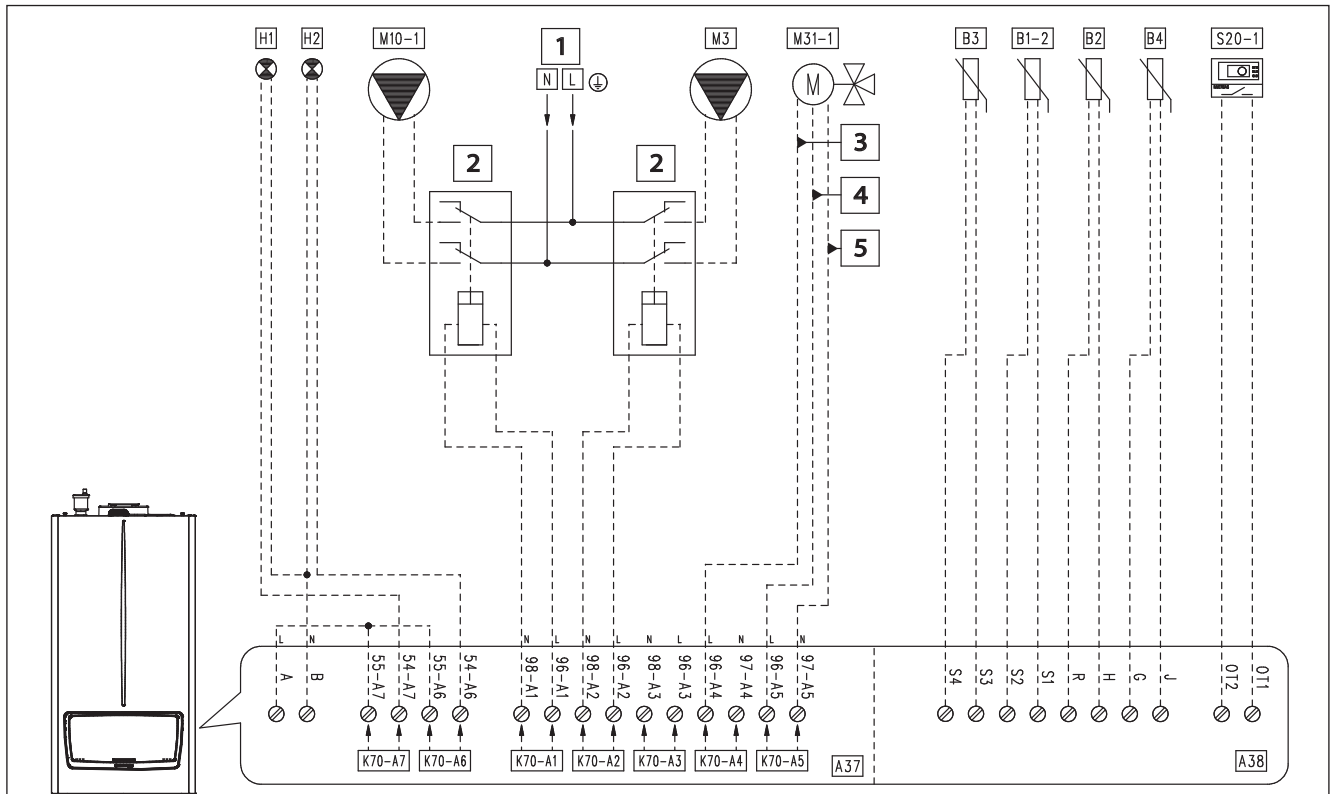

“HYDRAULIC SETTINGS”

parameter configuration table (Technician menu)

Parameter/menu name	Setting
“Relay settings” submenu:	
- K70-A1	- Zone 1 pump
- K70-A2	- Domestic hot water pump
- K70-A3	- Relay not used
- K70-A4	- Mixing valve: closes
- K70-A5	- Mixing valve: opens
- K70-A6	- Burner on
- K70-A7	- Error
System pump configuration	- Not used
- System sensor	- C.H. + DHW mode
“Mixed zone” submenu:	
- Mixed zone selection	- 1
- Valve time	- 150
- Type of heating request	- Climatic curve outside temperature and room thermostat
- DHW request type	- Sensor
- Parallel mode	- Disabled

Key:

- A37 - Connection sheet (loads)
- A38 - Connection card (signals)
- B1-2 - System flow probe (NTC) (optional)
- B2 - Domestic hot water probe (NTC) (optional)
- B3 - Flow probe (Low temperature) (NTC) (optional)
- B4 - External probe (NTC) (optional)
- H1 - “ERROR” indicator light (230 Vac) (optional)
- H2 - “Burner on” indicator light (230 Vac) (optional)
- M3 - DHW pump (optional)
- M10-1 - Zone 1 circulator pump (optional)
- M31-1 - Mixing valve - zone 1 (optional)
- S20-1 - Zone 1 room thermostat (optional)
- 1 - 230 Vac - 50 Hz
- 2 - External relay (optional) 230 vAC coil Max 0,1 A
- 3 - Close
- 4 - Open
- 5 - Common

**26.11 WIRING DIAGRAM: DHW ZONE - HYDRAULIC SEPARATOR -
- 2 DIRECT ZONES - OPENTHERM THERMOSTATS**

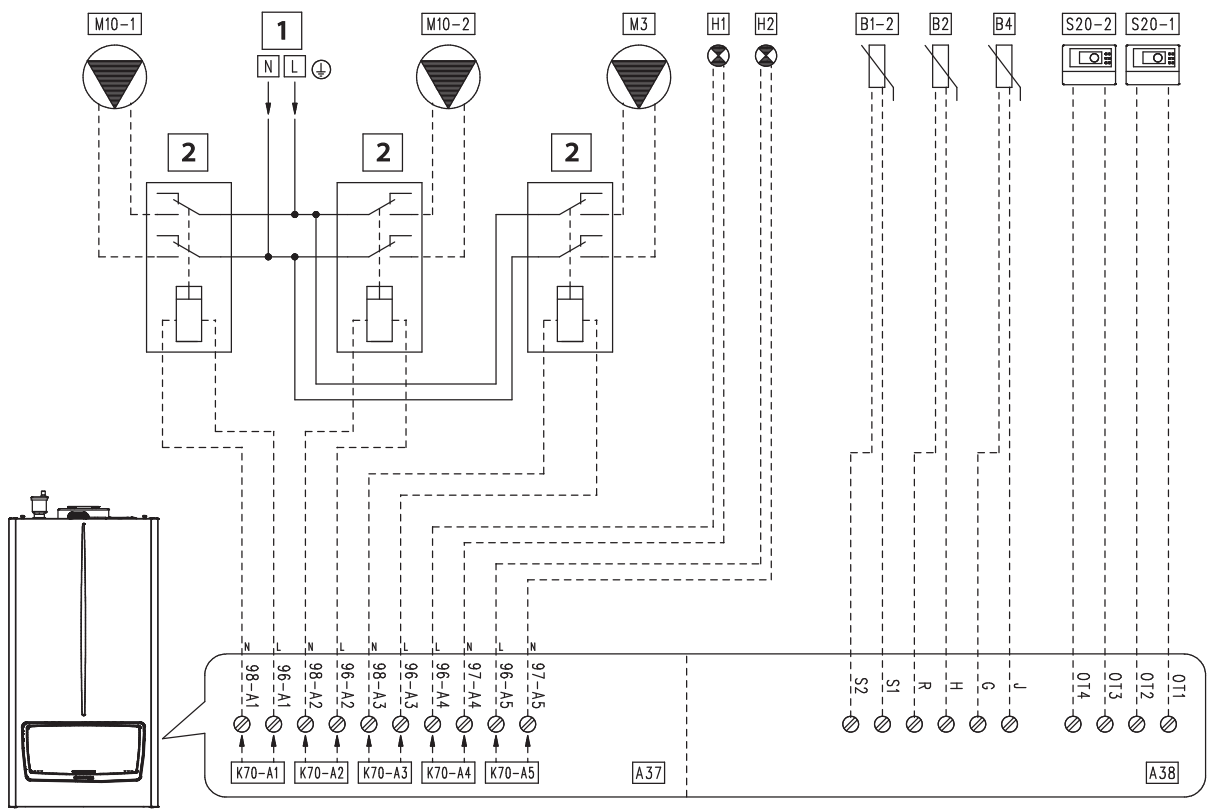

"HYDRAULIC SETTINGS" parameter configuration table (Technician menu)	
Parameter/menu name	Setting
"Relay settings" submenu:	
- K70-A1	- Zone 1 pump
- K70-A2	- Zone 2 pump
- K70-A3	- Domestic hot water pump
- K70-A4	- Error
- K70-A5	- Burner on
- K70-A6	- Relay not used
- K70-A7	- Relay not used
System pump configuration	
- System sensor	- Heating + domestic hot water mode
- Type of heating request	- Room thermostat setpoint
- DHW request type	- Sensor
- Parallel mode	- Disabled

- Key:
- A37 - Connection sheet (loads)
 - A38 - Connection card (signals)
 - B1-2 - System flow probe (NTC) (optional)
 - B2 - Domestic hot water probe (NTC) (optional)
 - B4 - External probe (NTC) (optional)
 - H1 - "ERROR" indicator light (230 Vac) (optional)
 - H2 - "Burner on" indicator light (230 Vac) (optional)
 - M3 - DHW pump (optional)
 - M10-1 - Zone 1 circulator pump (optional)
 - M10-2 - Zone 2 circulator pump (optional)
 - S20-1 - OpenTherm thermostat zone 1 (optional)
 - S20-2 - OpenTherm thermostat zone 2 (optional)
 - 1 - 230 Vac - 50 Hz
 - 2 - External relay (optional) 230 vAC coil Max 0,1 A
 - 3 - Close
 - 4 - Open
 - 5 - Common

VICTRIX PRO V2 EU

26.12

WIRING DIAGRAM: DHW ZONE - HYDRAULIC SEPARATOR - - ZONE 1, DIRECT

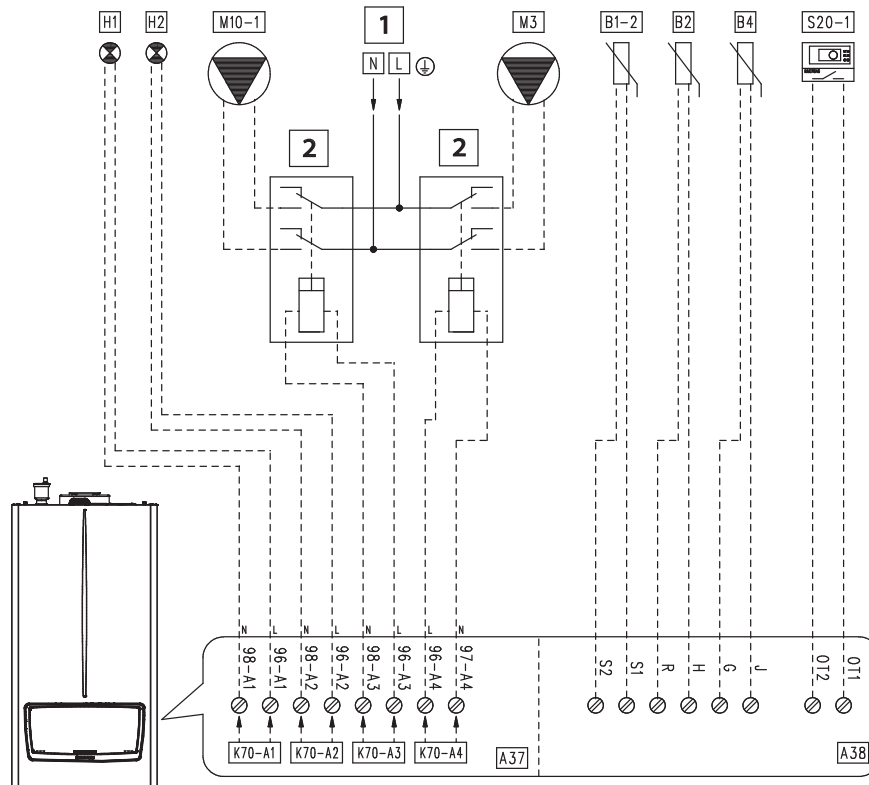

**“HYDRAULIC SETTINGS”
parameter configuration table (Technician menu)**

Parameter/menu name	Setting
“Relay settings” submenu:	
- K70-A1	- Error
- K70-A2	- Burner on
- K70-A3	- Zone 1 pump
- K70-A4	- Domestic hot water pump
- K70-A5	- Relay not used
- K70-A6	- Relay not used
- K70-A7	- Relay not used
System pump configuration	- Not used
- System sensor	- Heating + domestic hot water mode
- Type of heating request	- Climatic curve outside temperature and room thermostat
- DHW request type	- Sensor
- Parallel mode	- Disabled

Key:

- A37 - Connection sheet (loads)
- A38 - Connection card (signals)
- B1-2 - System flow probe (NTC) (optional)
- B2 - Domestic hot water probe (NTC) (optional)
- B4 - External probe (NTC) (optional)
- H1 - “ERROR” indicator light (230 Vac) (optional)
- H2 - “Burner on” indicator light (230 Vac) (optional)
- M3 - DHW pump (optional)
- M10-1 - Zone 1 circulator pump (optional)
- S20-1 - Zone 1 room thermostat (optional)
- 1 - 230 Vac - 50 Hz
- 2 - External relay (optional) 230 vAC coil Max 0,1 A

**26.13 WIRING DIAGRAM: DHW ZONE - HYDRAULIC SEPARATOR -
- DIRECT ZONE 1 - PARALLEL OPERATION**

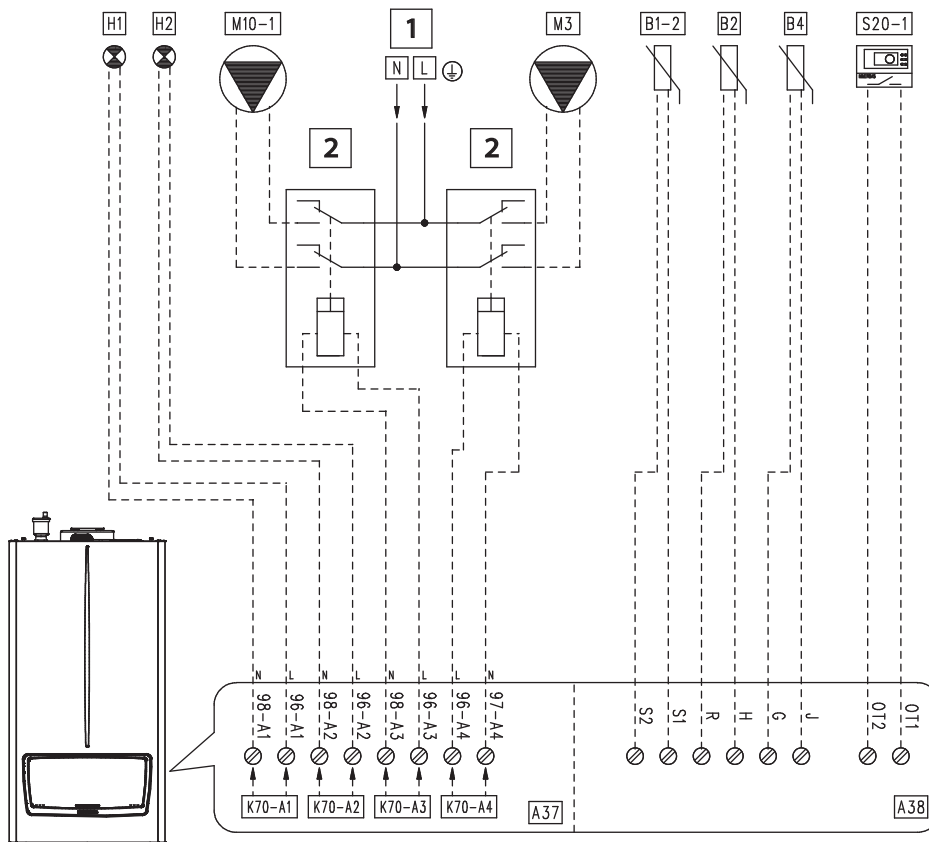

"HYDRAULIC SETTINGS" parameter configuration table (Technician menu)	
Parameter/menu name	Setting
"Relay settings" submenu:	
- K70-A1	- Error
- K70-A2	- Burner on
- K70-A3	- Zone 1 pump
- K70-A4	- Domestic hot water pump
- K70-A5	- Relay not used
- K70-A6	- Relay not used
- K70-A7	- Relay not used
System pump configuration	
- System sensor	- Heating + domestic hot water mode
- Type of heating request	- Climatic curve outside temperature and room thermostat
- DHW request type	- Sensor
- Parallel mode	- Enabled
With parallel mode enabled, the boiler uses the DHW setpoint and the maximum power used is the greater of the DHW and CH setpoint.	

- Key:
- A37 - Connection sheet (loads)
 - A38 - Connection card (signals)
 - B1-2 - System flow probe (NTC) (optional)
 - B2 - Domestic hot water probe (NTC) (optional)
 - B4 - External probe (NTC) (optional)
 - H1 - "ERROR" indicator light (230 Vac) (optional)
 - H2 - "Burner on" indicator light (230 Vac) (optional)
 - M3 - DHW pump (optional)
 - M10-1 - Zone 1 circulator pump (optional)
 - S20-1 - Zone 1 room thermostat (optional)
 - 1 - 230 Vac - 50 Hz
 - 2 - External relay (optional) 230 vAC coil Max 0,1 A

VICTRIX PRO V2 EU

26.14

WIRING DIAGRAM: DHW ZONE - HYDRAULIC SEPARATOR - - 2 DIRECT ZONES WITH CONSTANT SETPOINT CH DEMAND

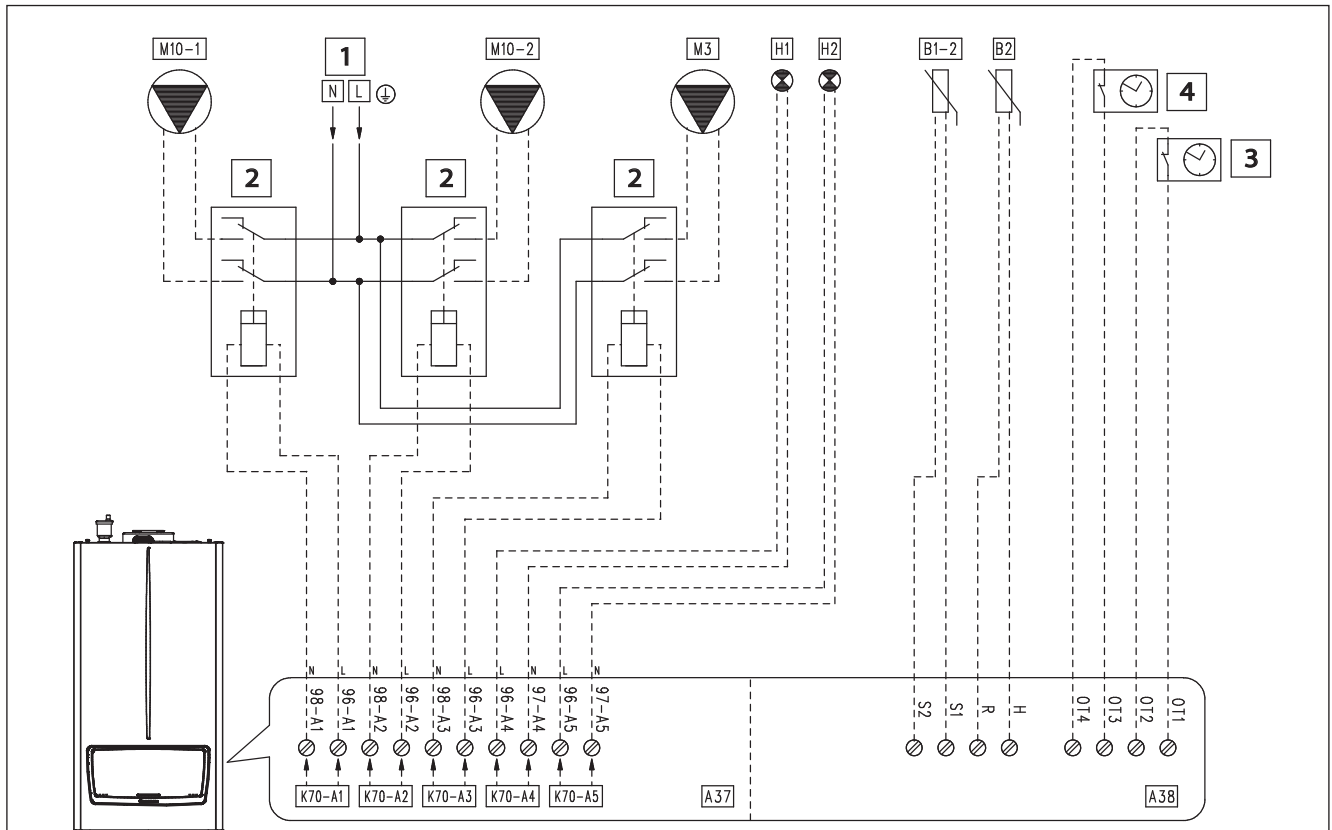

“HYDRAULIC SETTINGS”

parameter configuration table (Technician menu)

Parameter/menu name	Setting
“Relay settings” submenu:	
- K70-A1	- Zone 1 pump
- K70-A2	- Zone 2 pump
- K70-A3	- Domestic hot water pump
- K70-A4	- Error
- K70-A5	- Burner on
- K70-A6	- Relay not used
- K70-A7	- Relay not used
System pump configuration	
- System sensor	- Not used
- System settings	
- Type of heating request	- Heating + domestic hot water mode
- DHW request type	- Constant setpoint
- Parallel mode	- Sensor
	- Disabled

Note: when the contact of the programmer clock is closed, the heating setpoint is reduced according to the parameter "Reduction of ECO heating setpoint zone 1 and "Reduction of ECO heating setpoint zone 2". As an alternative to the programming clock, use the schedule)

Key:

- A37 - Connection sheet (loads)
- A38 - Connection card (signals)
- B1-2 - System flow probe (NTC) (optional)
- B2 - Domestic hot water probe (NTC) (optional)
- H1 - "ERROR" indicator light (230 Vac) (optional)
- H2 - "Burner on" indicator light (230 Vac) (optional)
- M3 - DHW pump (optional)
- M10-1 - Zone 1 circulator pump (optional)
- M10-2 - Zone 2 circulator pump (optional)
- 1 - 230 Vac - 50 Hz
- 2 - External relay (optional) 230 vAC coil Max 0,1 A
- 3 - Programming clock Zone 1 (optional)
- 4 - Programming clock Zone 2 (optional)

26.15

**WIRING DIAGRAM: DHW ZONE - HYDRAULIC SEPARATOR -
- 2 DIRECT ZONES WITH CH DEMAND WITH EXTERNAL PROBE**

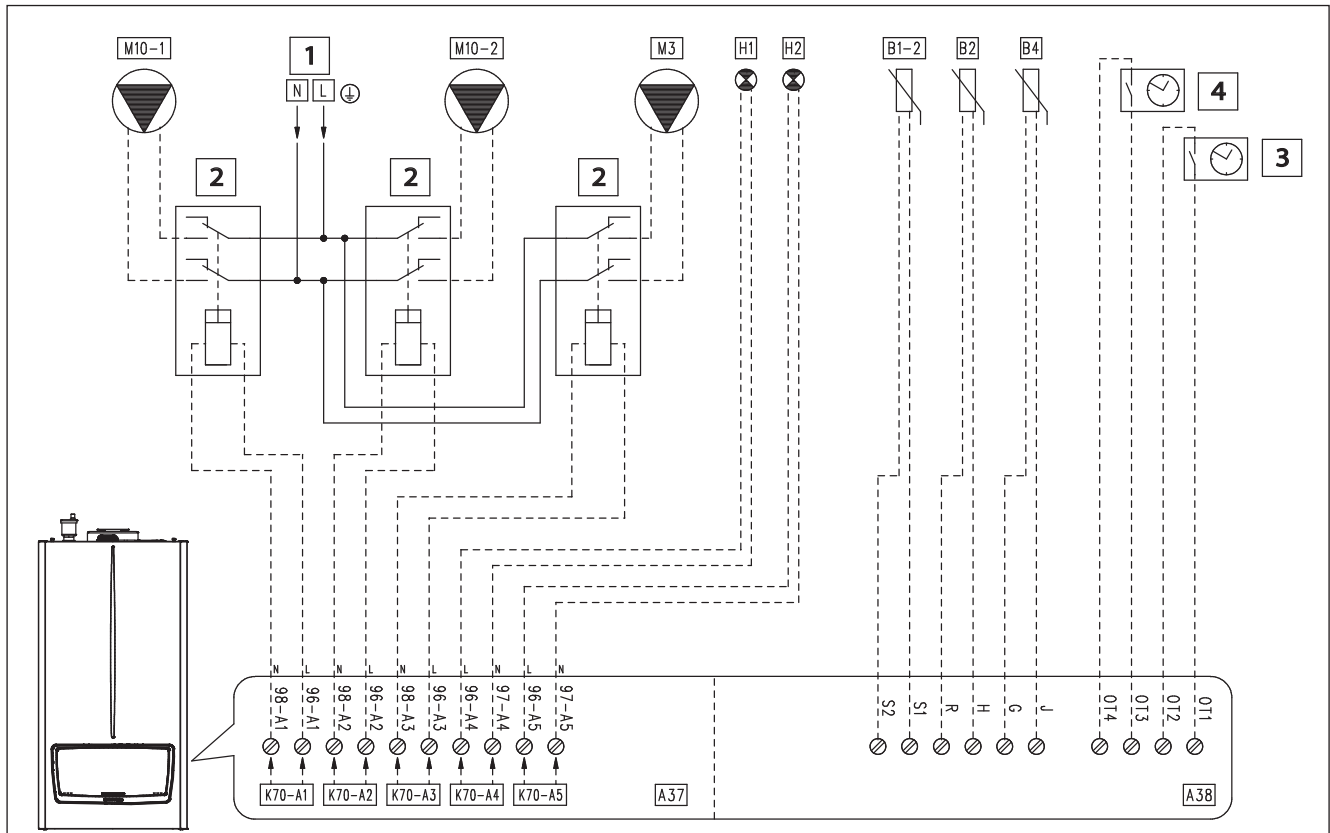

"HYDRAULIC SETTINGS" parameter configuration table (Technician menu)	
Parameter/menu name	Setting
"Relay settings" submenu:	
- K70-A1	- Zone 1 pump
- K70-A2	- Zone 2 pump
- K70-A3	- Domestic hot water pump
- K70-A4	- Error
- K70-A5	- Burner on
- K70-A6	- Relay not used
- K70-A7	- Relay not used
System pump configuration	
- System sensor	- Not used
System configuration	
- Type of heating request	- Heating + domestic hot water mode
- DHW request type	- External temperature climatic curve
- Parallel mode	- Sensor
	- Disabled
Note: when the contact of the programmer clock is closed, the heating setpoint is reduced according to the parameter "Reduction of ECO heating setpoint zone 1 and "Reduction of ECO heating setpoint zone 2". As an alternative to the programming clock, use the schedule)	

- Key:
- A37 - Connection sheet (loads)
 - A38 - Connection card (signals)
 - B1-2 - System flow probe (NTC) (optional)
 - B2 - Domestic hot water probe (NTC) (optional)
 - B4 - External probe (NTC) (optional)
 - H1 - "ERROR" indicator light (230 Vac) (optional)
 - H2 - "Burner on" indicator light (230 Vac) (optional)
 - M3 - DHW pump (optional)
 - M10-1 - Zone 1 circulator pump (optional)
 - M10-2 - Zone 2 circulator pump (optional)
 - 1 - 230 Vac - 50 Hz
 - 2 - External relay (optional) 230 vAC coil Max 0,1 A
 - 3 - Programming clock Zone 1 (optional)
 - 4 - Programming clock Zone 2 (optional)

VICTRIX PRO V2 EU

26.16

WIRING DIAGRAM: DIRECT ZONE 1 WITH THE BOOSTER PUMP

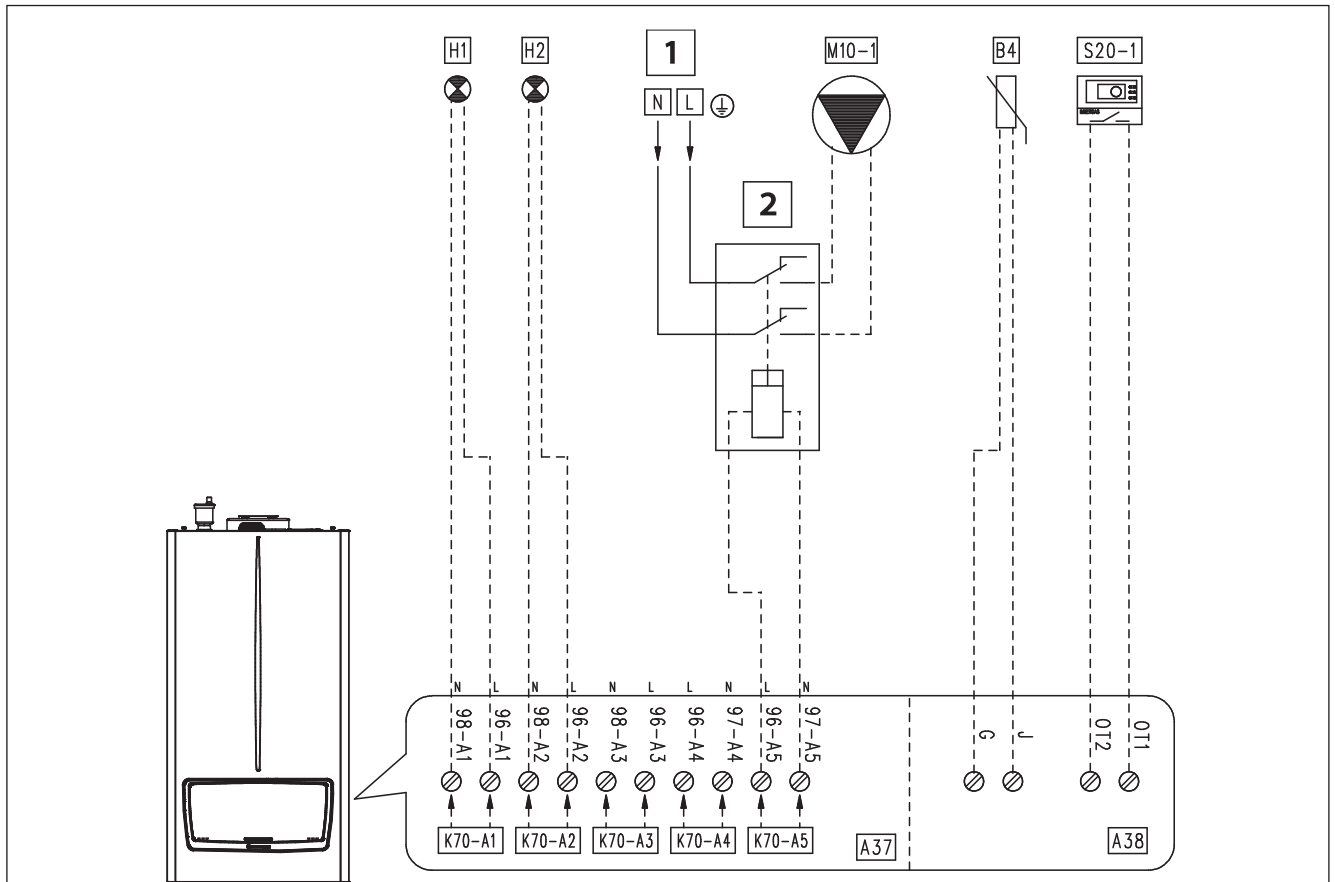

"HYDRAULIC SETTINGS" parameter configuration table (Technician menu)	
Parameter/menu name	Setting
"Relay settings" submenu:	
- K70-A1	- Error
- K70-A2	- Burner on
- K70-A3	- Relay not used
- K70-A4	- Relay not used
- K70-A5	- Booster pump
- K70-A6	- Relay not used
- K70-A7	- Relay not used
System pump configuration	- Not used
- System sensor	- Not used
- Type of heating request	- Climatic curve outside temperature and room thermostat
- DHW request type	- Sensor
- Parallel mode	- Disabled
Note: The booster pump is activated together with the appliance's pump though not simultaneously	

Key:

- A37 - Connection sheet (loads)
- A38 - Connection card (signals)
- B4 - External probe (NTC) (optional)
- H1 - "ERROR" indicator light (230 Vac) (optional)
- H2 - "Burner on" indicator light (230 Vac) (optional)
- M10-1 - Zone 1 circulator pump (optional)
- S20-1 - Zone 1 room thermostat (optional)
- S50 - DHW Thermostat/Contact
- 1 - 230 Vac - 50 Hz
- 2 - External relay (optional) 230 vAC coil Max 0,1 A

26.17 WIRING DIAGRAM: VICTRIX PRO V2 EU REMOTE CONTROL

Key:

- A25 - CLIP-IN (optional) **code: 3.034122**
- A38 - Connection card (signals)
- S20 - Room thermostat (optional)
- 1 - Cable type: J-Y(St)Y 2x2x0,6. Maximum permitted length: 50 m
- 2 - Address = 0

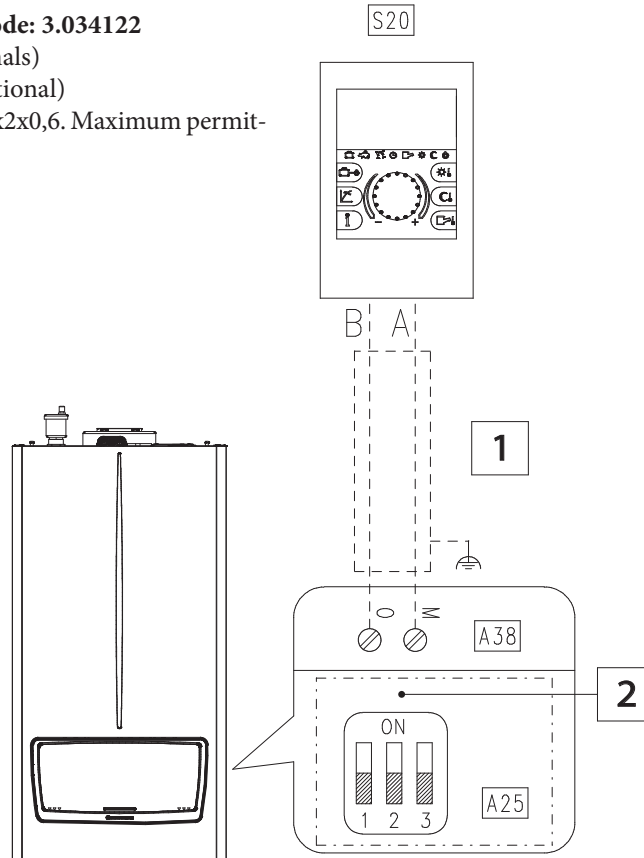

Technical Notes:

- The jumper X40 must be removed.
- The parameter 'Heating request type' must be set as 'Room thermostat setpoint' (default value).
- It is possible to connect the following sensors to the device and read them via BUS:
 - External probe (B4);
 - DHW probe (B2);
 - DHW Contact or Thermostat (S50).
- The DHW can be managed locally (appropriately configure the 3-way valve via the parameters in the "Relay settings" menu).

VICTRIX PRO V2 EU

26.18

WIRING DIAGRAM: CONNECTION TO BMS SYSTEM

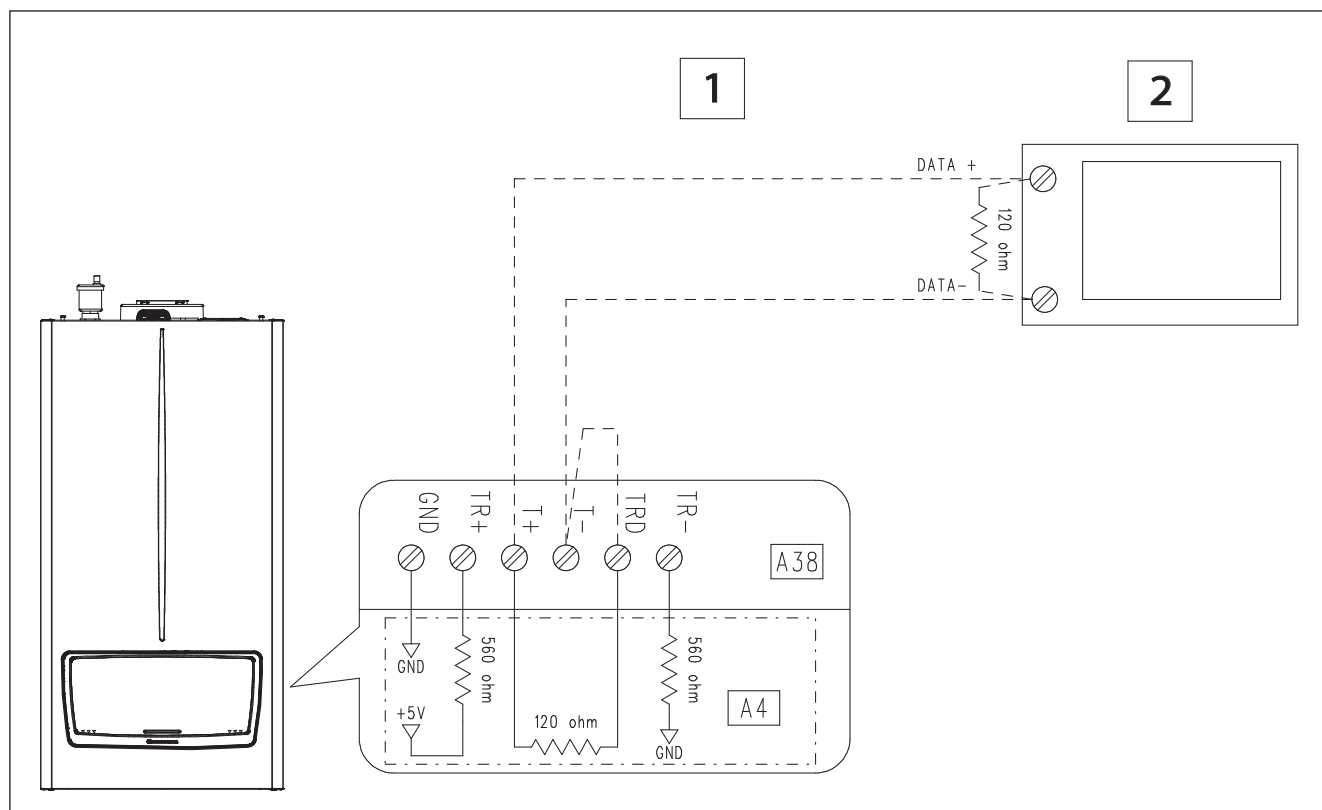

Key:

- A4 - Display board
- A38 - Connection card (signals)
- 1 - Cable type: twisted pair (20 / 22 AWG)
- 2 - BMS (modbus master) (optional)

Technical Notes:

- The jumper X40 must be removed.
- The Modbus parameters can be found in the 'TECHNICIAN/SYSTEM SETTINGS/Modbus parameters' menu.
- The parameter 'Heating request type' must be set as 'Room thermostat setpoint' (default value).
- It is possible to connect the following sensors to the device and read them via BUS:
 - System flow probe (B1-2);
 - External probe (B4);
 - DHW probe (B2);
 - DHW Contact or Thermostat (S50).
- The DHW can be managed locally (appropriately configure the 3-way valve via the parameters in the "Relay settings" menu).
- BMS: a pull-up resistance and a pull-down resistance must be present on the bus.
- In the diagram, it is assumed that the two pull up and pull down resistances are already present in the external appliance (for this reason, TR+ should not be connected with T+ and TR- with T-).
- The resistance (120 ohm) is required on both sides of the BUS (*bridging between terminals 'TRD' and 'T-' and adding the 120ohm resistance, BMS device side, is the responsibility of the installer*).

26.19

WIRING DIAGRAM: SIMPLE BUS CASCADE CONNECTION

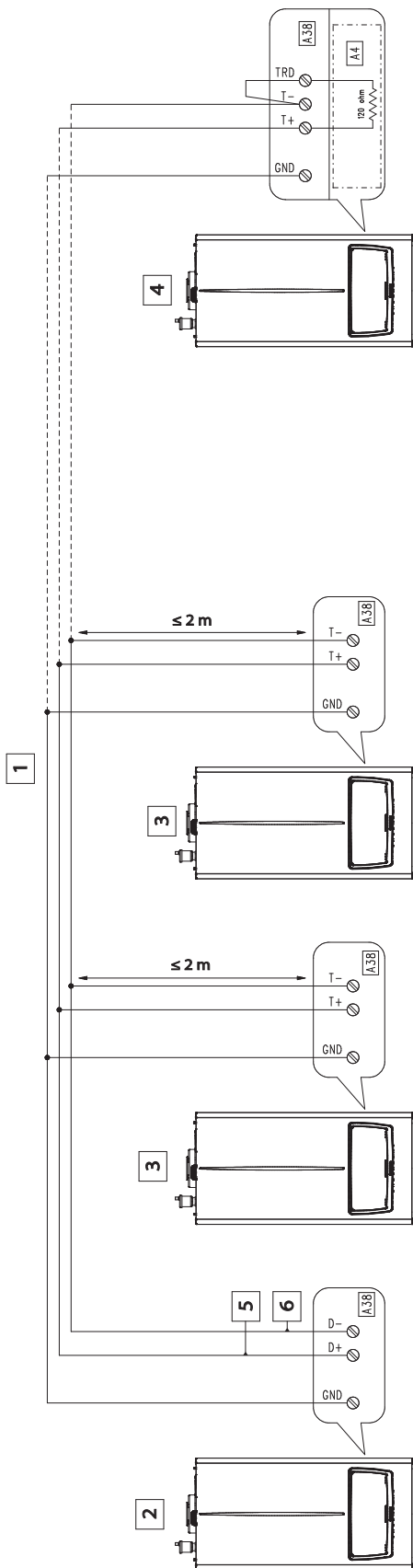

Key:

- A4 - Display board
- A38 - Connection card (signals)
- 1 - Cable type: 2 x twisted pair (20 / 22 AWG)*
- 2 - Master Boiler
- 3 - Slave Boiler
- 4 - Slave boiler (last)
- 5 - Data +
- 6 - Date -

Technical Notes:

- The jumper X40 must be removed.
- The communication BUS between the devices of the simple cascade is via Modbus protocol (RS485).
- The Modbus parameters, which can be configured via "MENU", have no effect on the simple cascade but serve for the BMS.
- In one pair of the twisted pair, connect the 'Data +' and 'Data -' signals, and in the other pair, connect the 'GND'.
- The jumper between "TRD" and "T-" terminals is set up by the Installer (the 120ohm electric resistance is already on the generator).

VICTRIX PRO V2 EU

27

TECHNICAL DATA

		VICTRIX PRO V2 35 EU	VICTRIX PRO V2 55 EU	VICTRIX PRO V2 60 EU
Maximum nominal heat input	kW	34.9	51.0	59.9
Maximum nominal gas heat input 20% H2NG	kW	33.5	49,3	57.0
Min. heat input	kW	3.9	5.4	7.8
Min. gas heat input 20% H2NG	kW	3.6	5.3	7.5
Maximum useful heat output (80/60°C)	kW	33.9	49.8	58.5
Maximum useful heat output (80/60°C) gas 20% H2NG	kW	32,5	48,1	55,7
Min. useful heat output (80/60°C)	kW	3,7	5.1	7.5
Min. useful heat output (80/60°C) gas 20% H2NG	kW	3.4	5.0	7.2
Maximum useful heat output (50/30°C)	kW	36,9	54.2	64.0
Maximum useful heat output (40/30°C)	kW	37,6	54.5	64,9
Efficiency at nominal heat output (80/60°C)	%	97.0	97.6	97.7
Efficiency at nominal heat output (50/30°C)	%	105.8	106.2	106.8
Efficiency at nominal heat output (40/30°C)	%	107.7	106.8	108.3
Efficiency at min. heat output (80/60°C)	%	94,0	95.2	96.2
Efficiency at min. heat output (50/30°C)	%	105.7	106.5	106.6
Efficiency at min. heat output (40/30°C)	%	107.2	108.3	109,4
Adjustable central heating temperature	°C	15-90	15-90	15-90
System max. working temperature	°C	95	95	95
System max. working pressure	bar	4.4	4.4	4.4
Head available with 1000 l/h flow rate	kPa (m c.a.)	58,0 (5,80)	68,0 (6,80)	111,0 (11,10)
Gas flow rate at METHANE burner (G20)	m ³ /h	from 0,41 to 3,69	from 0,57 to 5,40	from 0,83 to 6,34
Gas flow rate at LPG burner (G31)	kg/h	from 0,30 to 2,71	from 0,42 to 3,96	from 0,61 to 4,65
Useful heat output at Pn (η100) ref. UNI EN 15502-1	%	109,8	109,5	109,7
Useful heat output at Pn (η30) ref. UNI EN 15502-1	%	96.8	98.0	97.6
Electric power supply	V/Hz	230 - 50	230 - 50	230 - 50
Nominal power absorption	A	1	1.8	2.2
Installed electric power	W	130	158	295
Fan max absorbed power	W	45	65	95
Pump max absorbed power	W	72	73	175
Power absorbed in stand-by	W	5	6	6
Electric insulation rating	IP	X5D	X5D	X5D
Boiler water content	litres	2.4	2.8	3.2
Weight of empty boiler	kg	50	57	61

Technical note

The minimum and maximum head data (Pa) of the fan are displayed on pages 88 and 89

27.1		TECHNICAL DATA		
		VICTRIX PRO V2 68 EU	VICTRIX PRO V2 80 EU	VICTRIX PRO V2 100 EU
Maximum nominal heat input	kW	65.0	75.0	93.0
Maximum nominal heat input gas 20% H2NG	kW	62.0	72.0	88.7
Min. heat input	kW	7.8	7.8	10.1
Min. gas heat input 20% H2NG	kW	7.5	7.5	9.4
Maximum useful heat output (80/60°C)	kW	63.4	73,2	90,9
Maximum useful heat output (80/60°C) gas 20% H2NG	kW	60.5	70.3	86,7
Min. useful heat output (80/60°C)	kW	7.5	7.5	9.8
Min. useful heat output (80/60°C) gas 20% H2NG	kW	7.2	7.2	9.1
Maximum useful heat output (50/30°C)	kW	69.2	79.4	98,8
Maximum useful heat output (40/30°C)	kW	70.1	79.4	100,6
Efficiency at nominal heat output (80/60°C)	%	97.5	97.6	97.7
Efficiency at nominal heat output (50/30°C)	%	106.5	105,9	106.2
Efficiency at nominal heat output (40/30°C)	%	107.8	105.8	108.2
Efficiency at min. heat output (80/60°C)	%	96.2	96.2	96.6
Efficiency at min. heat output (50/30°C)	%	106.6	106.6	107.3
Efficiency at min. heat output (40/30°C)	%	109,4	109,4	107.9
Adjustable central heating temperature	°C	15-90	15-90	15-90
System max. working temperature	°C	95	95	95
System max. working pressure	bar	4.4	4.4	6
Head available with 2400 l/h flow rate	kPa (m c.a.)	85,0 (8,50)	85,0 (8,50)	97,0 (9,70)
Gas flow rate at METHANE burner (G20)	m ³ /h	from 0,83 to 6,88	from 0,83 to 7,94	from 1,07 to 9,84
Gas flow rate at LPG burner (G31)	kg/h	from 0,61 to 5,05	from 0,61 to 5,83	from 0,78 to 7,22
Useful heat output at Pn (η_{100}) ref. UNI EN 15502-1	%	109,6	109,8	109,8
Useful heat output at Pn (η_{30}) ref. UNI EN 15502-1	%	97.7	98.0	98.0
Electric power supply	V/Hz	230 - 50	230 - 50	230 - 50
Nominal power absorption	A	2.3	2.5	2.7
Installed electric power	W	300	320	330
Fan max absorbed power	W	103	120	155
Pump max absorbed power	W	175	175	175
Power absorbed in stand-by	W	6	6	6
Electric insulation rating	IP	X5D	X5D	X5D
Boiler water content	litres	3.2	3.2	9.0
Weight of empty boiler	kg	61	61	95

Technical note

The minimum and maximum head data (Pa) of the fan are displayed on pages 88 and 89

VICTRIX PRO V2 EU

27.2		TECHNICAL DATA		
		VICTRIX PRO V2 120 EU	VICTRIX PRO V2 150 EU	VICTRIX PRO V2 180 EU
Maximum nominal heat input	kW	114,5	141,0	170.0
Maximum nominal heat input gas 20% H2NG	kW	109.0	131,3	160,6
Min. heat input	kW	11.7	29.0	34.7
Min. gas heat input 20% H2NG	kW	11.0	27.5	32.9
Maximum useful heat output (80/60°C)	kW	112.3	138.3	166,9
Maximum useful heat output (80/60°C) gas 20% H2NG	kW	106.9	128,8	157.7
Min. useful heat output (80/60°C)	kW	11.3	28.3	33.8
Min. useful heat output (80/60°C) gas 20% H2NG	kW	10.6	26.8	32,1
Maximum useful heat output (50/30°C)	kW	121,7	149,9	180,2
Maximum useful heat output (40/30°C)	kW	124.1	151,2	182.8
Efficiency at nominal heat output (80/60°C)	%	98.1	98.1	98.2
Efficiency at nominal heat output (50/30°C)	%	106.3	106.3	106.0
Efficiency at nominal heat output (40/30°C)	%	108.4	107.2	107.5
Efficiency at min. heat output (80/60°C)	%	96.5	97.6	97.5
Efficiency at min. heat output (50/30°C)	%	107.6	108.1	108.2
Efficiency at min. heat output (40/30°C)	%	108.9	108.8	108.6
Adjustable central heating temperature	°C	15-90	15-90	15-90
System max. working temperature	°C	95	95	95
System max. working pressure	bar	6	6	6
Head available with 2400 l/h flow rate	kPa (m c.a.)	101,0 (10,1)	117,0 (11,7)	117,0 (11,7)
Gas flow rate at METHANE burner (G20)	m ³ /h	from 1,24 - to 12,12	from 3,07 - to 14,92	from 3,67 - to 18,0
Gas flow rate at LPG burner (G31)	kg/h	from 0,91 - to 8,89	from 2,25 - to 10,95	from 2,70 -to 13,2
Useful heat output at Pn (η100) ref. UNI EN 15502-1	%	109,2	108,5	108,4
Useful heat output at Pn (η30) ref. UNI EN 15502-1	%	98,0	97,7	98,2
Electric power supply	V/Hz	230 - 50	230 - 50	230 - 50
Nominal power absorption	A	3	3.2	2.8
Installed electric power	W	410	580	520
Fan max absorbed power	W	220	247	200
Pump max absorbed power	W	175	258	298
Power absorbed in stand-by	W	6	6.5	6
Electric insulation rating	IP	X5D	X5D	X5D
Boiler water content	litres	10.0	12.0	15.0
Weight of empty boiler	kg	101	112	148

Technical note

The minimum and maximum head data (Pa) of the fan are displayed on pages 88 and 89

		Methane (G20)	LPG (G31)
Maximum heat input of gas G20	m ³ /h	3.69	
Min. heat input of gas G20	m ³ /h	0.41	
Maximum heat input of gas G31	kg/h		2.71
Min. heat input of gas G31	kg/h		0.30
Supply pressure	mbar	20	37
Flue flow rate at maximum nominal heat output	kg/h	54	56
Flue flow rate at maximum nominal heat output gas 20% H2NG	kg/h	57	
Flue flow rate at min heat output	kg/h	6	6
Flue flow rate at min heat output gas 20% H2NG	kg/h	7	
Chimney losses with burner on (100% Pn) (80/60°C)	% (W)	2,7 (937)	
Chimney losses with burner off	% (W)	0,03 (10)	
Casing losses with burner on (100% Pn) (80/60°C)	% (W)	0,31 (110)	
Casing losses with burner off	% (W)	0,32 (111)	
Flue gas temperature Maximum Heat Input	°C	79	83
Flue gas temperature Min. Heat Input	°C	60	62
CO ₂ at Maximum Heat Input	%	9.6	10.6
CO ₂ at Maximum Heat Input gas 20% H2NG	%	8.4	
CO ₂ at Min. Heat Input	%	9.1	10.5
CO ₂ at Min. Heat Input gas 20% H2NG	%	8.1	
CO at Maximum Heat Input	ppm	240	280
CO at Maximum Heat Input gas 20% H2NG	ppm	110	
CO at Min. Heat Input	ppm	3	2
CO at Min. Heat Input gas 20% H2NG	ppm	1	
Weighted CO	mg/kWh	27	32
NO _x at the Maximum Heat Input	mg/kWh	60	68
NO _x at Min. Heat Input	mg/kWh	24	42
Weighted NO _x	mg/kWh	37	40
NO _x class	-	6	6

Gas flow rates refer to net calorific value at a temperature of 15°C and at a pressure of 1013 mbar.

Flue gas temperature values refer to an air inlet temperature of 15°C and flow/return temperature of 80/60°C.

VICTRIX PRO V2 35 - 55 - 60 - 68 - 80 EU

28.1 VICTRIX PRO V2 55 EU COMBUSTION FEATURES

		Methane (G20)	LPG (G31)
Maximum heat input of gas G20	m ³ /h	5.40	
Min. heat input of gas G20	m ³ /h	0.57	
Maximum heat input of gas G31	kg/h		3.96
Min. heat input of gas G31	kg/h		0.42
Supply pressure	mbar	20	37
Flue flow rate at maximum nominal heat output	kg/h	82	84
Flue flow rate at maximum nominal heat output gas 20% H2NG	kg/h	88	
Flue flow rate at min heat output	kg/h	9	9
Flue flow rate at min heat output gas 20% H2NG	kg/h	9	
Chimney losses with burner on (100% Pn) (80/60°C)	% (W)	2,3 (1173)	
Chimney losses with burner off	% (W)	0,02 (10)	
Casing losses with burner on (100% Pn) (80/60°C)	% (W)	0,1 (51)	
Casing losses with burner off	% (W)	0,23 (115)	
Flue gas temperature Maximum Heat Input	°C	74	74
Flue gas temperature Min. Heat Input	°C	60	61
CO ₂ at Maximum Heat Input	%	9.2	10.3
CO ₂ at Maximum Heat Input gas 20% H2NG	%	8.0	
CO ₂ at Min. Heat Input	%	8.7	9.6
CO ₂ at Min. Heat Input gas 20% H2NG	%	7,9	
CO at Maximum Heat Input	ppm	220	250
CO at Maximum Heat Input gas 20% H2NG	ppm	80	
CO at Min. Heat Input	ppm	3	3
CO at Min. Heat Input gas 20% H2NG	ppm	3	
Weighted CO	mg/kWh	24	25
NO _x at the Maximum Heat Input	mg/kWh	58	63
NO _x at Min. Heat Input	mg/kWh	27	31
Weighted NO _x	mg/kWh	39	30
NO _x class	-	6	6

Gas flow rates refer to net calorific value at a temperature of 15°C and at a pressure of 1013 mbar.

Flue gas temperature values refer to an air inlet temperature of 15°C and flow/return temperature of 80/60°C.

VICTRIX PRO V2 35 - 55 - 60 - 68 - 80 EU

28.2

VICTRIX PRO V2 60 EU COMBUSTION FEATURES

		Methane (G20)	LPG (G31)
Maximum heat input of gas G20	m ³ /h	6.34	
Min. heat input of gas G20	m ³ /h	0.83	
Maximum heat input of gas G31	kg/h		4.65
Min. heat input of gas G31	kg/h		0.61
Supply pressure	mbar	20	37
Flue flow rate at maximum nominal heat output	kg/h	96	97
Flue flow rate at maximum nominal heat output gas 20% H2NG	kg/h	100	
Flue flow rate at min heat output	kg/h	13	13
Flue flow rate at min heat output gas 20% H2NG	kg/h	14	
Chimney losses with burner on (100% Pn) (80/60°C)	% (W)	2,2 (1318)	
Chimney losses with burner off	% (W)	0,02 (10)	
Casing losses with burner on (100% Pn) (80/60°C)	% (W)	0,1 (60)	
Casing losses with burner off	% (W)	0,2 (121)	
Flue gas temperature Maximum Heat Input	°C	71	71
Flue gas temperature Min. Heat Input	°C	65	61
CO ₂ at Maximum Heat Input	%	9.3	10.4
CO ₂ at Maximum Heat Input gas 20% H2NG	%	8.3	
CO ₂ at Min. Heat Input	%	9.0	10.0
CO ₂ at Min. Heat Input gas 20% H2NG	%	7,9	
CO at Maximum Heat Input	ppm	160	170
CO at Maximum Heat Input gas 20% H2NG	ppm	90	
CO at Min. Heat Input	ppm	3	3
CO at Min. Heat Input gas 20% H2NG	ppm	1	
Weighted CO	mg/kWh	17	15
NO _x at the Maximum Heat Input	mg/kWh	41	42
NO _x at Min. Heat Input	mg/kWh	38	42
Weighted NO _x	mg/kWh	41	40
NO _x class	-	6	6

Gas flow rates refer to net calorific value at a temperature of 15°C and at a pressure of 1013 mbar.

Flue gas temperature values refer to an air inlet temperature of 15°C and flow/return temperature of 80/60°C.

VICTRIX PRO V2 35 - 55 - 60 - 68 - 80 EU

28.3 VICTRIX PRO V2 68 EU COMBUSTION FEATURES

		Methane (G20)	LPG (G31)
Maximum heat input of gas G20	m ³ /h	6.88	
Min. heat input of gas G20	m ³ /h	0.83	
Maximum heat input of gas G31	kg/h		5.05
Min. heat input of gas G31	kg/h		0.61
Supply pressure	mbar	20	37
Flue flow rate at maximum nominal heat output	kg/h	104	106
Flue flow rate at maximum nominal heat output gas 20% H2NG	kg/h	108	
Flue flow rate at min heat output	kg/h	13	13
Flue flow rate at min heat output gas 20% H2NG	kg/h	14	
Chimney losses with burner on (100% Pn) (80/60°C)	% (W)	2,4 (1560)	
Chimney losses with burner off	% (W)	0,02 (10)	
Casing losses with burner on (100% Pn) (80/60°C)	% (W)	0,1 (65)	
Casing losses with burner off	% (W)	0,19 (121)	
Flue gas temperature Maximum Heat Input	°C	74	74
Flue gas temperature Min. Heat Input	°C	65	61
CO ₂ at Maximum Heat Input	%	9.3	10.4
CO ₂ at Maximum Heat Input gas 20% H2NG	%	8.3	
CO ₂ at Min. Heat Input	%	9.0	10.0
CO ₂ at Min. Heat Input gas 20% H2NG	%	7,9	
CO at Maximum Heat Input	ppm	180	200
CO at Maximum Heat Input gas 20% H2NG	ppm	90	
CO at Min. Heat Input	ppm	3	3
CO at Min. Heat Input gas 20% H2NG	ppm	1	
Weighted CO	mg/kWh	17	20
NO _x at the Maximum Heat Input	mg/kWh	45	41
NO _x at Min. Heat Input	mg/kWh	38	42
Weighted NO _x	mg/kWh	39	31
NO _x class	-	6	6

Gas flow rates refer to net calorific value at a temperature of 15°C and at a pressure of 1013 mbar.

Flue gas temperature values refer to an air inlet temperature of 15°C and flow/return temperature of 80/60°C.

VICTRIX PRO V2 35 - 55 - 60 - 68 - 80 EU

28.4
VICTRIX PRO V2 80 EU COMBUSTION FEATURES

		Methane (G20)	LPG (G31)
Maximum heat input of gas G20	m ³ /h	7.94	
Min. heat input of gas G20	m ³ /h	0.83	
Maximum heat input of gas G31	kg/h		5.83
Min. heat input of gas G31	kg/h		0.61
Supply pressure	mbar	20	37
Flue flow rate at maximum nominal heat output	kg/h	121	122
Flue flow rate at maximum nominal heat output gas 20% H2NG	kg/h	126	
Flue flow rate at min heat output	kg/h	13	13
Flue flow rate at min heat output gas 20% H2NG	kg/h	14	
Chimney losses with burner on (100% Pn) (80/60°C)	% (W)	2,3 (1725)	
Chimney losses with burner off	% (W)	0,01 (10)	
Casing losses with burner on (100% Pn) (80/60°C)	% (W)	0,1 (75)	
Casing losses with burner off	% (W)	0,16 (121)	
Flue gas temperature Maximum Heat Input	°C	79	77
Flue gas temperature Min. Heat Input	°C	65	61
CO ₂ at Maximum Heat Input	%	9.2	10.4
CO ₂ at Maximum Heat Input gas 20% H2NG	%	8,2	
CO ₂ at Min. Heat Input	%	9.0	10.0
CO ₂ at Min. Heat Input gas 20% H2NG	%	7,9	
CO at Maximum Heat Input	ppm	230	300
CO at Maximum Heat Input gas 20% H2NG	ppm	110	
CO at Min. Heat Input	ppm	3	3
CO at Min. Heat Input gas 20% H2NG	ppm	1	
Weighted CO	mg/kWh	24	17
NO _x at the Maximum Heat Input	mg/kWh	64	71
NO _x at Min. Heat Input	mg/kWh	38	42
Weighted NO _x	mg/kWh	33	29
NO _x class	-	6	6

Gas flow rates refer to net calorific value at a temperature of 15°C and at a pressure of 1013 mbar.

Flue gas temperature values refer to an air inlet temperature of 15°C and flow/return temperature of 80/60°C.

VICTRIX PRO V2 100 - 120 - 150 EU

28.5 VICTRIX PRO V2 100 EU COMBUSTION FEATURES

		Methane (G20)	LPG (G31)
Maximum heat input of gas G20	m ³ /h	9,84	
Min. heat input of gas G20	m ³ /h	1.07	
Maximum heat input of gas G31	kg/h		7.22
Min. heat input of gas G31	kg/h		0.78
Supply pressure	mbar	20	37
Flue flow rate at maximum nominal heat output	kg/h	149	153
Flue flow rate at maximum nominal heat output gas 20% H2NG	kg/h	155	
Flue flow rate at min heat output	kg/h	17	17
Flue flow rate at min heat output gas 20% H2NG	kg/h	18	
Chimney losses with burner on (100% Pn) (80/60°C)	% (W)	2,2 (2046)	
Chimney losses with burner off	% (W)	0,02 (15)	
Casing losses with burner on (100% Pn) (80/60°C)	% (W)	0,1 (93)	
Casing losses with burner off	% (W)	0,18 (166)	
Flue gas temperature Maximum Heat Input	°C	74	75
Flue gas temperature Min. Heat Input	°C	60	60
CO ₂ at Maximum Heat Input	%	9.3	10.3
CO ₂ at Maximum Heat Input gas 20% H2NG	%	8.3	
CO ₂ at Min. Heat Input	%	8.9	9,9
CO ₂ at Min. Heat Input gas 20% H2NG	%	7,9	
CO at Maximum Heat Input	ppm	220	230
CO at Maximum Heat Input gas 20% H2NG	ppm	115	
CO at Min. Heat Input	ppm	7	7
CO at Min. Heat Input gas 20% H2NG	ppm	7	
Weighted CO	mg/kWh	23	22
NO _x at the Maximum Heat Input	mg/kWh	60	52
NO _x at Min. Heat Input	mg/kWh	7	9
Weighted NO _x	mg/kWh	34	33
NO _x class	-	6	6

Gas flow rates refer to net calorific value at a temperature of 15°C and at a pressure of 1013 mbar.

Flue gas temperature values refer to an air inlet temperature of 15°C and flow/return temperature of 80/60°C.

28.6
VICTRIX PRO V2 120 EU COMBUSTION FEATURES

		Methane (G20)	LPG (G31)
Maximum heat input of gas G20	m ³ /h	12,12	
Min. heat input of gas G20	m ³ /h	1.24	
Maximum heat input of gas G31	kg/h		8.89
Min. heat input of gas G31	kg/h		0.91
Supply pressure	mbar	20	37
Flue flow rate at maximum nominal heat output	kg/h	185	188
Flue flow rate at maximum nominal heat output gas 20% H2NG	kg/h	192	
Flue flow rate at min heat output	kg/h	19	20
Flue flow rate at min heat output gas 20% H2NG	kg/h	20	
Chimney losses with burner on (100% Pn) (80/60°C)	% (W)	1,8 (2061)	
Chimney losses with burner off	% (W)	0,02 (19)	
Casing losses with burner on (100% Pn) (80/60°C)	% (W)	0,1 (114)	
Casing losses with burner off	% (W)	0,18 (209)	
Flue gas temperature Maximum Heat Input	°C	71	72
Flue gas temperature Min. Heat Input	°C	60	60
CO ₂ at Maximum Heat Input	%	9.2	10.3
CO ₂ at Maximum Heat Input gas 20% H2NG	%	8,2	
CO ₂ at Min. Heat Input	%	8.9	10.1
CO ₂ at Min. Heat Input gas 20% H2NG	%	7,9	
CO at Maximum Heat Input	ppm	205	220
CO at Maximum Heat Input gas 20% H2NG	ppm	95	
CO at Min. Heat Input	ppm	4	4
CO at Min. Heat Input gas 20% H2NG	ppm	4	
Weighted CO	mg/kWh	19	19
NO _x at the Maximum Heat Input	mg/kWh	50	45
NO _x at Min. Heat Input	mg/kWh	14	15
Weighted NO _x	mg/kWh	30	23
NO _x class	-	6	6

Gas flow rates refer to net calorific value at a temperature of 15°C and at a pressure of 1013 mbar.

Flue gas temperature values refer to an air inlet temperature of 15°C and flow/return temperature of 80/60°C.

VICTRIX PRO V2 100 - 120 - 150 EU

28.7
VICTRIX PRO V2 150 EU COMBUSTION FEATURES

		Methane (G20)	LPG (G31)
Maximum heat input of gas G20	m ³ /h	14.92	
Min. heat input of gas G20	m ³ /h	3.07	
Maximum heat input of gas G31	kg/h		10,95
Min. heat input of gas G31	kg/h		2.25
Supply pressure	mbar	20	37
Flue flow rate at maximum nominal heat output	kg/h	226	229
Flue flow rate at maximum nominal heat output gas 20% H2NG	kg/h	234	
Flue flow rate at min heat output	kg/h	48	51
Flue flow rate at min heat output gas 20% H2NG	kg/h	51	
Chimney losses with burner on (100% Pn) (80/60°C)	% (W)	1,8 (2538)	
Chimney losses with burner off	% (W)	0,02 (24)	
Casing losses with burner on (100% Pn) (80/60°C)	% (W)	0,1 (141)	
Casing losses with burner off	% (W)	0,18 (260)	
Flue gas temperature Maximum Heat Input	°C	73	73
Flue gas temperature Min. Heat Input	°C	60	60
CO ₂ at Maximum Heat Input	%	9.3	10.4
CO ₂ at Maximum Heat Input gas 20% H2NG	%	8.3	
CO ₂ at Min. Heat Input	%	8.9	9.6
CO ₂ at Min. Heat Input gas 20% H2NG	%	7,9	
CO at Maximum Heat Input	ppm	215	230
CO at Maximum Heat Input gas 20% H2NG	ppm	95	
CO at Min. Heat Input	ppm	7	9
CO at Min. Heat Input gas 20% H2NG	ppm	4	
Weighted CO	mg/kWh	20	24
NO _x at the Maximum Heat Input	mg/kWh	66	63
NO _x at Min. Heat Input	mg/kWh	32	27
Weighted NO _x	mg/kWh	34	38
NO _x class	-	6	6

Gas flow rates refer to net calorific value at a temperature of 15°C and at a pressure of 1013 mbar.

Flue gas temperature values refer to an air inlet temperature of 15°C and flow/return temperature of 80/60°C.

28.8
VICTRIX PRO V2 180 EU COMBUSTION FEATURES

		Methane (G20)	LPG (G31)
Maximum heat input of gas G20	m ³ /h	18.0	
Min. heat input of gas G20	m ³ /h	3.67	
Maximum heat input of gas G31	kg/h		13.2
Min. heat input of gas G31	kg/h		2.7
Supply pressure	mbar	20	37
Flue flow rate at maximum nominal heat output	kg/h	277	274
Flue flow rate at maximum nominal heat output gas 20% H2NG	kg/h	292	
Flue flow rate at min heat output	kg/h	60	62
Flue flow rate at min heat output gas 20% H2NG	kg/h	63	
Chimney losses with burner on (100% Pn) (80/60°C)	% (W)	1,7 (2890)	
Chimney losses with burner off	% (W)	0,02 (31)	
Casing losses with burner on (100% Pn) (80/60°C)	% (W)	0,1 (170)	
Casing losses with burner off	% (W)	0,18 (306)	
Flue gas temperature Maximum Heat Input	°C	72	71
Flue gas temperature Min. Heat Input	°C	60	60
CO ₂ at Maximum Heat Input	%	9.1	10.5
CO ₂ at Maximum Heat Input gas 20% H2NG	%	8.0	
CO ₂ at Min. Heat Input	%	8.5	9.3
CO ₂ at Min. Heat Input gas 20% H2NG	%	7.5	
CO at Maximum Heat Input	ppm	210	305
CO at Maximum Heat Input gas 20% H2NG	ppm	100	
CO at Min. Heat Input	ppm	10	9
CO at Min. Heat Input gas 20% H2NG	ppm	4	
Weighted CO	mg/kWh	25	28
NO _x at the Maximum Heat Input	mg/kWh	70	73
NO _x at Min. Heat Input	mg/kWh	28	22
Weighted NO _x	mg/kWh	42	34
NO _x class	-	6	6

Gas flow rates refer to net calorific value at a temperature of 15°C and at a pressure of 1013 mbar.

Flue gas temperature values refer to an air inlet temperature of 15°C and flow/return temperature of 80/60°C.

VICTRIX PRO V2 EU

29 HIGH POWER REMOTE CONTROL FOR SINGLE BOILER (CODE 3.020358)



Dimensions (H x L x P) mm 138 x 90 x 28

The remote control allows to manage, control and program operation of the generator it is connected to. It can be set and programmed via parameters that allow to guarantee ideal temperature conditions at all times of the day and night for each individual day of the week, both for the C.H. system and the D.H.W. system (VICTRIX PRO V2 EU coupled to a storage tank unit). The remote control enables the user to keep under control and within reach all the important information regarding operation of the appliance and the heating system with the ability to easily act on settings with no need to go to where the generator is physically present. The climate chrono-thermostat incorporated into the Remote control enables the system flow temperature to be adjusted to the actual needs of the room being heated, in order to obtain the desired room temperature with extreme precision and therefore with evident saving in running costs.

The Remote control connects to the boiler via a "Clip-in" communication board and 2 BUS data cables, from which it is powered.

The ADVANCED TEMPERATURE CONTROL device belongs to Class V* or VI.

It allows you to increase the seasonal energy efficiency value by 3%* or 4%

29.1

FEATURES

It is connected to the boiler by a **Clip-in communication board, code: 3.034122** and 2 BUS cables of a maximum length of 50 metres.

Once the Remote control and communication board are connected, remove the jumper "X40" present as per standard on the boiler board.

With Remote control installation it is also advisable to install an external probe.

The device allows you to:

- manage a maximum of one zone;
- set two room temperature values, one for day (comfort temperature) and one for night (reduced temperature);
- manage the temperature of the DHW (with a storage tank unit managed as zone or using a 3-way valve);
- select the functioning mode for CH and DHW for each individual hydraulic circuit:
 - comfort temperature functioning,
 - reduced temperature functioning,
 - adjustable anti-freeze temperature functioning;

- manage the boiler flow temperature depending on the external temperature and the room temperature with setting of the climatic curve;
- obtain information regarding the system:
 - system temperature,
 - operating mode,
 - counter data,
 - timer program,
 - pump operation status;
- set the operation parameters:
 - functioning times,
 - system mode,
 - DHW,
 - direct circuit,
 - date and time;
- display, via self-diagnosis system, of any functioning anomalies with error codes;
- show the date, time, day of the week and the boiler temperature on the display.

30 CASCADE AND ZONE REGULATOR (CODE 3.034119)

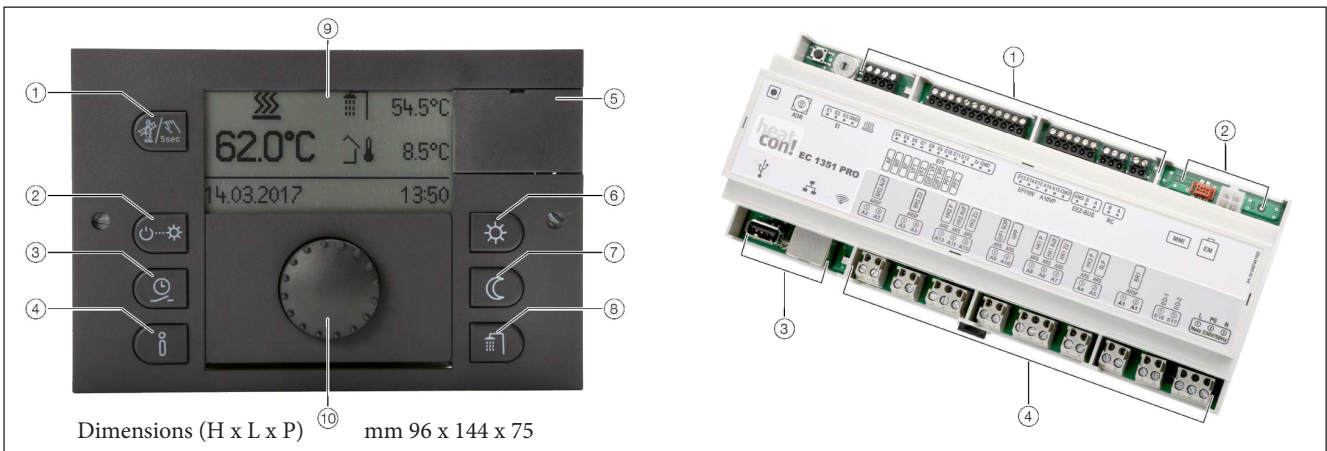

Dimensions (H x L x P) mm 96 x 144 x 75

INTERFACE KEY:

- 1 - "Emissions measurement / manual mode" button.
- 2 - "Operating scenarios/mode" button
- 3 - "Programming" button
- 4 - "Info" button
- 5 - Connection lid
- 6 - "Well-being/economy temperature" button
- 7 - "Reduced temperature" button
- 8 - "Daily hot water temperature" button
- 9 - Display
- 10 - Knob (push and turn)

TERMINAL BOARD KEY:

- 1 - Low voltage connections
- 2 - Bus data for system expansion
- 3 - USB/network connection
- 4 - 230V connections

The cascade and zones regulator allows to manage, control and program the functioning sequence of the connected boilers. It consists of 2 elements, an interface with display and push-button panel and a terminal board for electric connections from DIN rail to be inserted inside the electric panel of the thermal control unit.

The 2 elements are connected by flat cable for data transmission included in the kit Code: 3.034119.

N.B.: to connect the Cascade and zone regulator kit to the generators, therefore, the terminal board for electric connections, you must use the **Clip-in communication board code: 3.034122** for each boiler connected.

When the Cascade and zone regulator is installed, it will be necessary to remove the "X40" jumper included in the standard configuration of the boiler P.C.B.

30.1 FEATURES

The electrical connection is made with 2 wires powered at 230V (diameter 1.5 mm²).

The connection to the boiler, therefore to Clip-in, takes place with 2 BUS data cables with maximum length of 50 metres.

The Cascade and zone regulator allows to:

- manage up to 8 appliances in set configuration;
- manage a maximum of three zones (2 of which may be mixed) and a zone enabled for DHW production via separate storage tank.
- up to 2 expansion kits can be added Code: 3.034124 for each cascade and zone regulator, to control additional zones (one zone for each expansion);
- it is possible to replicate the system described above up to 3 times with 3 cascade and zone regulator kits, 6 expansion kits and 1 signal repeater kit; in this case up to 15 zones of the system and 3 DHW protection circuits can be managed;
- set two room temperature values: one for day (comfort temperature) and one for night (reduced temperature) with the aid of the zone manager kit;

- manage the domestic hot water temperature also with the programmable anti-Legionella function with a specific calendar (coupled to a storage tank unit managed as a zone with a pump);
- select the operation mode for space heating and DHW at:
 - comfort temperature,
 - reduced temperature,
 - adjustable antifreeze temperature;
- manage the boiler flow temperature depending on the external temperature with setting of the climatic curve;
- obtain information regarding the system:
 - system temperature,
 - operating mode,
 - counter data,
 - timer program,
 - pump operation status,
 - operation and values of the variable inputs;
- impostare i parametri di funzionamento:

VICTRIX PRO V2 EU

- set the operation parameters:
 - functioning times,
 - system mode,
 - DHW,
 - direct circuit, mixed 1, mixed 2,
 - date and time;
- display, via self-diagnosis system, of any functioning anomalies with error codes;
- show the date, time, day of the week and the boiler temperature on the display,
- the regulator has a specific section for setting the solar system parameters.
- the regulator board features specific terminals for the variable inputs and outputs, that need to be used based on the specificity of the system.

Variable inputs

- the variable inlets can be used to send a dry contact of request from one or more on/off room thermostats (the thermostats can then control, for example, zone pumps, satellite substations, etc through relay boxes; when the thermostat calls, it energises a relay which makes the pump/satellite substation start up, and it also sends an output dry contact to the cascade and zone regulator on the variable input);
- with a set of boilers, the common flow probe always uses a variable input;

Variable outlets

- the solar pump always uses 1 variable outlet;
- the recirculation pump always uses 1 variable outlet.

30.2

CASCADE AND ZONE REGULATOR DIAGRAM OF CONNECTIONS AND TERMINALS

The terminal board of the cascade and zone regulator has network, low-voltage and signal connections. Some complementary products, intended to operate the

thermal system, will be connected to the relevant terminals on the terminal board of the same cascade and zone regulator.

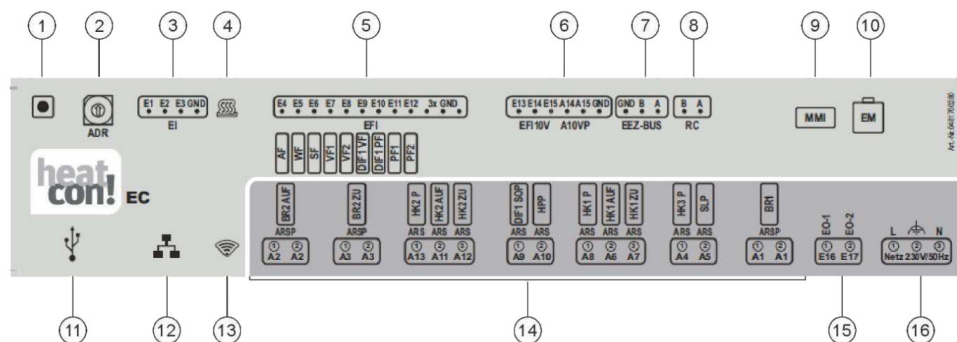

KEY:

- | | |
|---|---|
| <ul style="list-style-type: none"> 1 - Button: not used 2 - Address selector: used when there are 2 or more heatcon! 3 - Digital inputs: input for pulse sensor 4 - “Control” LED: displays the status of the connected appliance and BUS communication 5 - Temperature sensor inputs: connect the analogue temperature sensors here 6 - <u>Analogue</u> inputs/ <u>Analogue</u> outputs (0-10V) 7 - Connection Bus of the appliances 8 - Bifilar Bus h2B for zone manager: connect the heatcon! zone manager(s) 9 - MMI Heatcon! connection: connect the control interface of the Cascade and zone regulator here 10 - System Bus for heatcon! EM 100: connect the heatcon! EM 100 expansions here | <ul style="list-style-type: none"> 11 - USB connection: to be used to connect the components of the 2.0 VICTRIX PRO V2 EU Remote management kit (initial configuration instead of using the Cascade and zone regulator, at the connection via Internet browser) 12 - Network connection (Ethernet, RJ45): to be used for the initial configuration via Internet browser, for Remote management and to upgrade heatcon! firmware 13 - “Network” LED: displays the status of the Internet connection 14 - Outputs (230V AC): connect the pumps and valves here (ARS relay terminal N.O. contact – LINE; ARSP relay terminals N.O. contact) 15 - Digital inputs (230V AC): input opto isolator to count operating hours 16 - Electric power supply: 230 V ±10 %, 50 Hz |
|---|---|

31

ZONE MANAGER KIT (CODE 3.034120)



Dimensions (H x L x P) mm 82 x 82 x 26

The zone manager (not traditional On/Off) functions only when coupled with the cascade regulator and allows regulation of the room temperature of one of the zones into which the plant is divided (both in individual and cascade installation). Also allows to adapt the system flow temperature to the actual needs of the room being heated, in order to obtain the desired room temperature with extreme precision.

The settings of the climatic zone of reference, done beforehand on the cascade and zone regulator, can be modified.

The zone manager is powered directly by the cascade and zone regulator via 2 BUS data cables.

31.1

FEATURES

The connection to the cascade and zone regulator takes place with 2 BUS data cables with maximum length of 100 metres and allows to:

- manage a maximum of one zone;
- set two room temperature values, one for day (comfort temperature) and one for night (reduced temperature);
- select the operation mode for heating the specific zone:
 - comfort temperature functioning,
 - reduced temperature functioning,
 - adjustable anti-freeze temperature functioning;
- manage the boiler flow temperature depending on the external temperature and the room temperature with setting of the climatic curve;
- obtain information regarding the system:
 - system temperature,
 - operating mode,
 - counter data,
 - timer program,
 - pump operation status,
 - operation and values of the variable inputs;
- set the operation parameters:
 - functioning times,
 - system mode,
 - date and time;

Display	Description
	Heating in automatic mode, at comfort or economy temperature.
	Central heating (Party/Boost/Shower).
	Automatic mode stop, based on stop temperature.
	Stop (start)
	Standby mode (standby/holiday), no adjustment of the room setpoint possible.
	Controlled summer switch off by weather conditions.
	Temporary manual adjustment of room setpoint in automatic mode (magic wand).
	Central heating demand active, as long as a power supply was selected.
	Cooling demand active, as long as a power supply was selected.
Error	Error message.

Class	Contribution to room central heating seasonal energy efficiency	Combinations
VI	+4%	VICTRIX PRO V2 EU cascade and zone regulator coupled to VICTRIX PRO V2 EU zone manager kit and to external temperature probe
VIII	+5%	VICTRIX PRO V2 EU cascade and zone regulator coupled to number 3 VICTRIX PRO V2 EU zone manager kit

VICTRIX PRO V2 EU

32

KIT FOR REMOTE MANAGEMENT 2.0 (CODE 3.034121)

(EXCLUSIVELY IN COMBINATION WITH THE CASCADE AND ZONE REGULATOR)

DESCRIPTION.

The remote management kit 2.0 allows you to manage the heating systems viewing and modifying a variety of operating parameters, all from smartphone or tablet through a specific app.

At any time, it allows the definition of individual switching times as well as setting two temperature levels—comfort temperature and reduced temperature—for each room or group

of rooms. The kit has a stick with USB port for the Wi-Fi connection, a USB-LAN adapter and 1 PC connection cable. Connection to the Internet is achieved with Wi-Fi modem (not included in the kit) or by means of LAN network connection.

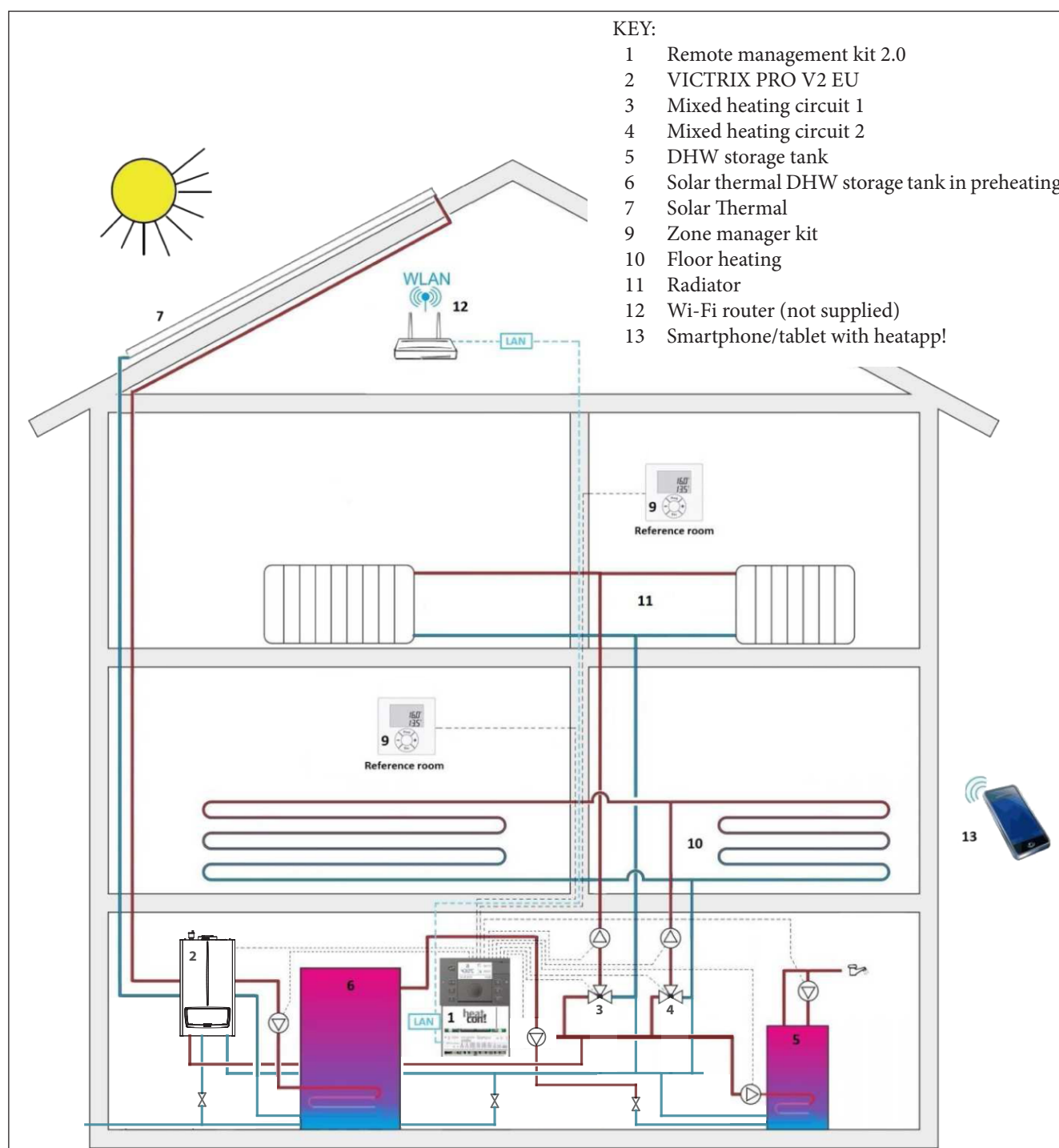

INITIAL OPERATION/ INITIAL CONFIGURATION

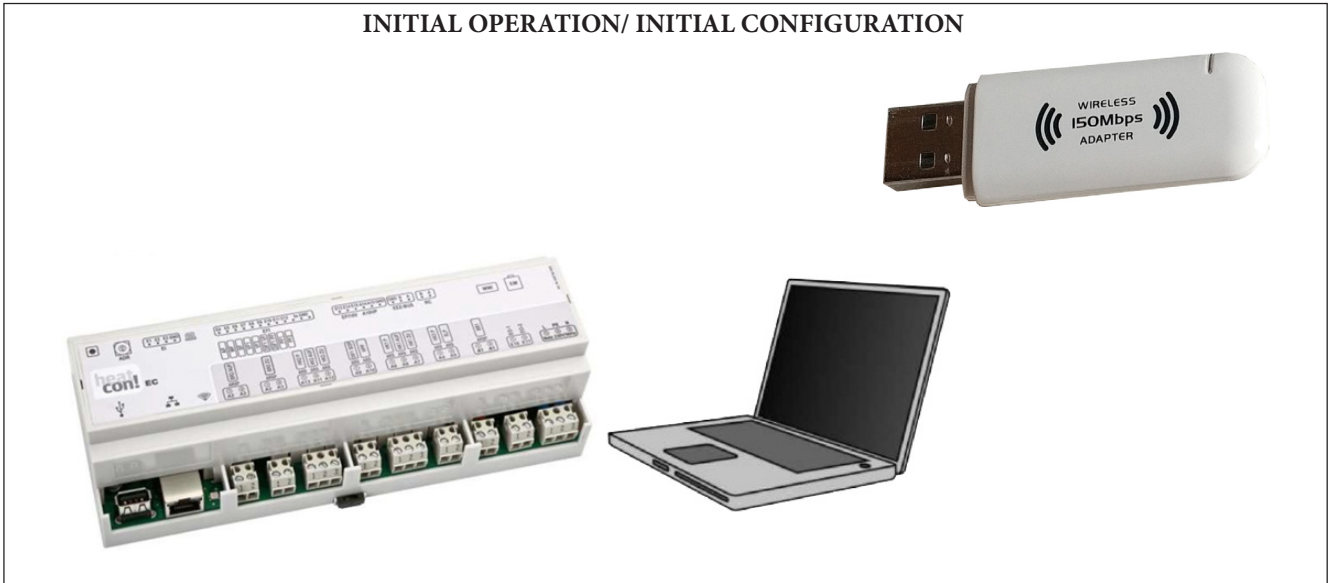

DESCRIPTIONS

The heatapp! WLAN-Stick, or simply **stick**, is used if a permanent connection to the home network via a network cable is not possible.

A Wi-Fi connection to the home network is then made via the USB stick.

CONNECTING THE HEATAPP! STICK

Connect the WLAN heatapp! stick to the USB port of the Cascade and zone regulator terminal board.

A local WiFi name is created.

Instructions:

- The Wi-Fi stick must remain plugged in to ensure the correct functioning of heatcon!
- You require the access data of the Wi-Fi network for the following set-up steps.
- Changes to the Wi-Fi network (new router, different password, etc.) can impair the operation of heatapp! and may require resetting of the heatapp! configuration.

INITIAL OPERATION

Select the wireless settings of your tablet/smartphone.

- Connect to the WiFi network created by heatcon!
- Depending on the settings of your tablet/smartphone, the browser will either open automatically or you open the browser on your device and enter 10.0.0.1 in the address line.
- Follow the installation wizard instructions.
- Remove the installation stick at the end of the installation wizard.

TECHNICAL DATA

Wi-Fi	802.11b/g/n
Chip set	Coupled to heatapp!
Ambient conditions	
• Storage temperature	-25 ... +60 °C
• Operating temperature	-10 ... +50 °C
Weight	Approx. 20 g

USING HEATAPP! APP

To check the system remotely, the specific heatapp! application must be downloaded on an Android or iOS device.

Only one profile can be entered for each device.

The app provides instructions useful for the customer to start using the heatapp! system by helping them to install the app on their own mobile device and guiding them through the first few steps in using the app.

The heatapp! system can also be accessed from the Internet through the LAN network, but not using the "User" profile. From APP ("Owner" or "Expert" profile) and from Browser there are many common functions. From the APP you cannot perform the initial NETWORK configuration, complete monitoring is not available, the "group of rooms" temperatures can be set, while the "group of rooms" temperatures cannot be set from the browser, but the browser has complete monitoring and the initial network configuration can be performed.

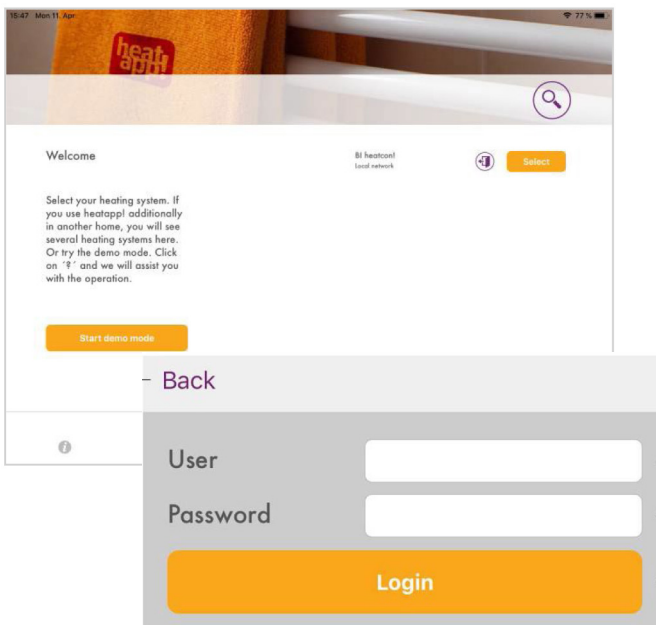

VICTRIX PRO V2 EU

33

VICTRIX PRO V2 EU RANGE SINGLE INSTALLATION OPTION

TEMPERATURE CONTROL Kit for VICTRIX PRO V2 EU	Code
High power remote control for single boiler	3.020358
CHRONO 7	3.021622
CRONO 7 WIRELESS	3.021624
External probe	3.015266
System flow probe	3.024245
DHW storage tank probe	3.025467
Cascade and zone regulator	3.034119
Clip-in communication board (for boiler coupled to Remote control or Cascade and zone regulator)	3.034122
Expansion (to manage 1 additional zone)*	3.034124
Zone manager (modulating temperature control)*	3.034120
System flow probe*	3.015267
DHW storage tank probe*	3.015268
Solar collector probe PT1000*	3.019374
External probe*	3.024511
Remote management kit 2.0 (for management at a distance via App)*	3.034121
FLUE SYSTEMS kit for VICTRIX PRO V2 35 - 55 - 60 - 68 - 80 EU	Code
Vertical terminal Ø 80 (for roof exhaust)	3.034579
Vertical flue exhaust Ø 80 (in stainless steel)	3.024295
Intake stub pipe Ø 80 (configuration B ₂₃)	3.033759
Fan assisted horizontal kit Ø 80 (for chimney exhaust)	3.015254
Fan assisted horizontal terminal kit Ø 80 (for wall exhaust)**	3.015255
4 extension pipes Ø 80 (0,5 m long)	3.014642
4 extension pipes Ø 80 (1 m long)	3.012088
Extension pipe Ø 80 (2 m long)	3.016837
45° bend Ø 80	3.012092
4 90° bends Ø 80	3.012091
Separator Ø 80/80	3.012002
Concentric horizontal kit Ø 80/125 (for wall exhaust)**	3.033785
Concentric vertical kit Ø 80/125 (for roof exhaust, including valley gutter for sloped roofs)	3.033786
Valley gutter kit Ø 80/125 for flat roofs	3.015249
Extension pipe Ø 80/125 (1 m long)	3.018667
Extension pipe Ø 80/125 (2 m long)	3.015246
2 45° bends Ø 80/125	3.015248
87° bend Ø 80/125	3.015247
Gaskets 10 pc. Ø 80 for separate flue	3.015378
Gaskets 10 pc. Ø 80 for concentric flue	3.015343
Gasket Ø 125 for concentric flue	3.015345
Clapet valve Ø 80 in stainless steel	3.033715
IPX5D top cover	3.033670
Flexible ducting system Ø 80 - (see Immergas price list)	Various codes

* Can only be coupled to Cascade and zone regulator

** Check whether wall exhaust is allowed by regulatory provisions in force and local regulations

FLUE SYSTEMS kit for VICTRIX PRO V2 100 - 120 - 150 EU	Code
Vertical terminal Ø 100 (for roof exhaust)	3.032713
Vertical flue exhaust Ø 100 (in stainless steel)	3.032714
Intake stub pipe Ø 100 (configuration B ₂₃)	3.033760
Fan assisted horizontal kit Ø 100 (for chimney exhaust)	3.032715
Fan assisted horizontal terminal kit Ø 100 (for wall exhaust)**	3.032716
4 extension pipes Ø 100 (0,5 m long)	3.031132
4 extension pipes Ø 100 (1 m long)	3.031373
4 extension pipes Ø 100 (2 m long)	3.032319
45° bend Ø 100	3.032195
4 87° bends Ø 100	3.032731
Separator Ø 100/100	3.032717
Concentric horizontal kit Ø 110/160 (for wall exhaust)**	3.033789
Concentric vertical kit Ø 110/160 (for roof exhaust, including valley gutter for sloped roofs)	3.033790
Extension pipe Ø 110/160 (1 m long)	3.031397
Extension pipe Ø 110/160 (2 m long)	3.031398
45° bend Ø 110/160	3.031395
87° bend Ø 110/160	3.031396
Gaskets 4 pc. Ø 100 for separate flue	3.032732
Gasket Ø 110 for concentric flue	3.015344
Clapet valve Ø 125 (for piping Ø 130) in stainless steel	3.033716
IPX5D top cover for VICTRIX PRO V2 100 - 120 EU	3.033671
IPX5D top cover for VICTRIX PRO V2 150 EU	3.033672
FLUE SYSTEMS kit for VICTRIX PRO V2 180 EU	Code
Vertical terminal Ø 160 (for roof exhaust)	3.034554
Vertical flue exhaust Ø 160 (in stainless steel)	3.034555
Intake stub pipe Ø 160 (configuration B ₂₃)	3.034565
Fan assisted horizontal kit Ø 160 (for chimney exhaust)	3.034556
Fan assisted horizontal terminal kit Ø 160 (for wall exhaust)**	3.034557
4 extension pipes Ø 160 (0,5 m long)	3.034559
4 extension pipes Ø 160 (1 m long)	3.034560
4 extension pipes Ø 160 (2 m long)	3.034561
45° bend Ø 160	3.034562
4 90° bends Ø 160	3.034563
Separator Ø 160/160	3.035122
Ø 160 for separate flue	3.034564
IPX5D top cover for VICTRIX PRO V2 180 EU	3.033689

** Check whether wall exhaust is allowed by regulatory provisions in force and local regulations

VICTRIX PRO V2 EU

HYDRAULIC and COMPLEMENT kits for VICTRIX PRO V2 35 - 55 - 60 - 68 - 80 EU		Code
INAIL safety devices kit for single boiler		3.023949
3-way valve for coupling separate storage tank unit		3.023950
IPX4D protection box for INAIL outdoor safety devices		3.024028
Hydraulic manifold		3.023951
Plate heat exchanger (with connections on RH side of the generator)		3.033676
Sludge remover		3.033673
VICTRIX PRO V2 adaptation with VICTRIX 50 - 75		3.023966
Anti-freeze resistance (up to -15 °C)		3.034125
Condensate passivator		3.033687
Condensate passivator granulate reload		3.034920
Condensate drain pump		3.020002
Outdoor cabinet		3.033680
Hydraulic manifolds including INAIL safety devices (for Cabinet code: 3.033680)		3.033681
Free-standing frame		3.032347
HYDRAULIC and COMPLEMENT kits for VICTRIX PRO V2 100 - 120 - 150 - 180 EU		Code
INAIL safety devices kit for single boiler		3.023949
3-way valve for coupling separate storage tank unit		3.023950
IPX4D protection box for INAIL outdoor safety devices		3.024028
Hydraulic manifold		3.023952
Plate heat exchanger (with connections on RH side of the generator)		3.033677
Sludge remover		3.033673
Anti-freeze resistance (up to -15 °C)		3.034125
Condensate passivator		3.033688
Condensate passivator granulate reload		3.034920
Condensate drain pump		3.020002
Outdoor cabinet***		3.033680
Hydraulic manifolds including INAIL safety devices (for Cabinet code: 3.033680)***		3.033681
Free-standing frame***		3.033686

*** except for model VICTRIX PRO V2 180 EU

34 VICTRIX PRO V2 EU RANGE IN SET CONFIGURATION INSTALLATION OPTION

TEMPERATURE CONTROLKIT for VICTRIX PRO V2 EU in SET CONFIGURATION	Code
High power remote control for single boiler(also in simple cascade)	3.020358
CHRONO 7	3.021622
CRONO 7 WIRELESS	3.021624
External probe (in simple cascade)	3.015266
System flow probe (in simple cascade)	3.024245
DHW storage tank probe (in simple cascade)	3.025467
Cascade and zone regulator	3.034119
Clip-in communication board (for boiler coupled to Remote control or Cascade and zone regulator)	3.034122
Expansion (to manage 1 additional zone)*	3.034124
Zone manager (modulating temperature control)*	3.034120
System flow probe*	3.015267
DHW storage tank probe*	3.015268
Solar collector probe PT1000*	3.019374
External probe*	3.024511
Remote management kit 2.0 (for management at a distance via App)*	3.034121
FLUE SYSTEMS kit for VICTRIX PRO V2 35 - 55 - 60 - 68 - 80 EU in SET CONFIGURATION	Code
Intake stub pipe Ø 80 (configuration B ₂₃)	3.033759
IPX5D top cover	3.033670
Flue exhaust manifold Ø 160 with flue adjusting devices (flue manifold for first 2 modules in cascade)	3.034257
Flue exhaust manifold Ø 160 with additional module flue adjusting devices (manifold added to module 2)	3.034258
Extension pipe Ø 160 (0,5 m long)	3.024659
Extension pipe Ø 160 (1 m long)	3.024516
87° bend Ø 160	3.024517
2 45° bends Ø 160	3.024518
FLUE SYSTEMS kit for VICTRIX PRO V2 100 - 120 - 150 EU in SET CONFIGURATION	Code
Intake stub pipe Ø 100 (configuration B ₂₃)	3.033760
IPX5D top cover for VICTRIX PRO V2 100 - 120 EU	3.033671
IPX5D top cover for VICTRIX PRO V2 150 EU	3.033672
Flue exhaust manifold Ø 200 with flue adjusting devices (flue manifold for first 2 modules in cascade)	3.034259
Flue exhaust manifold Ø 200 with additional module flue adjusting devices (manifold added to module 2)**	3.034260
Flue exhaust manifold Ø 250 with 4th additional module flue adjusting devices VICTRIX PRO V2 150 EU	3.034261
Flue exhaust manifold Ø 250 with 5th additional module flue adjusting devices VICTRIX PRO V2 150 EU	3.034262
Extension pipe Ø 200 (0,5 m long)	3.024663
Extension pipe Ø 200 (1 m long)	3.024662
Extension pipe Ø 250 (1 m long)	3.024668
87° bend Ø 200	3.024665
87° bend Ø 250	3.024670
2 45° bends Ø 200	3.024664
2 45° bends Ø 250	3.024669

* Can only be coupled to Cascade and zone regulator

** 3rd additional module VICTRIX PRO V2 100-120-150 EU or 4th or 5th additional module VICTRIX PRO V2 100-120 EU

VICTRIX PRO V2 EU

HYDRAULIC and COMPLEMENT kits for VICTRIX PRO V2 35 - 55 - 80 EU in SET CONFIGURATION	Code
Hydraulic manifold in set configuration (for first 2 cascade modules)	3.032338
Hydraulic collector in set configuration, additional module (manifold added to module 2)	3.033669
INAIL safety devices in set configuration	3.023955
IPX4D protection box for INAIL outdoor safety devices	3.024038
Hydraulic separator up to 100 kW for modules in set configuration	3.020839
Hydraulic separator up to 200 kW for modules in set configuration	3.021377
Hydraulic separator up to 400 kW for modules in set configuration	3.021378
Plate heat exchanger in set configuration	3.033678
Sludge remover in set configuration	3.033674
Antifreeze resistance (up to -15 °C) - (for single module)	3.034125
Condensate passivator for 2 VICTRIX PRO V2 35 EU	3.033687
Condensate passivator up to 170 kW	3.033688
Condensate passivator up to 700 kW	3.023662
Condensate passivator granulate reload (articles 3.033687 and 3.033688)	3.034920
Condensate passivator granulate reload (article 3.023662)	3.023663
Condensate drain pump (for single module)	3.020002
Outdoor cabinet (for single module)	3.033680
Hydraulic manifolds including INAIL safety devices (for Cabinet code: 3.033680)	3.033681
Free-standing frame (for single module)	3.032347
HYDRAULIC and COMPLEMENT kits for VICTRIX PRO V2 100 - 120 - 150 - 180 EU in SET CONFIGURATION	Code
Hydraulic manifold in set configuration (for first 2 cascade modules)	3.033667
Hydraulic collector in set configuration, additional module (manifold added to module 2)	3.033668
Hydraulic manifold in set configuration (for first 2 cascade modules)****	3.034938
Hydraulic collector in set configuration, additional module (manifold added to module 2)****	3.034939
INAIL safety devices in set configuration	3.023961
IPX4D protection box for INAIL outdoor safety devices	3.024038
Hydraulic separator up to 350 kW for modules in set configuration	3.023965
Hydraulic separator up to 600 kW for modules in set configuration	3.023962
Plate heat exchanger in set configuration	3.033679
Sludge remover in set configuration	3.033675
Antifreeze resistance (up to -15 °C) - (for single module)	3.034125
Condensate passivator up to 700 kW	3.023662
Condensate passivator granulate reload (article 3.023662)	3.023663
Condensate drain pump (for single module)	3.020002
Outdoor cabinet (for single module)***	3.033680
Hydraulic manifolds including INAIL safety devices (for Cabinet code: 3.033680)***	3.033681
Free-standing frame (for single module)***	3.033686
IPX5D top cover for VICTRIX PRO V2 180 EU ****	3.033689

***except for model VICTRIX PRO V2 180 EU

**** Exclusive kit for VICTRIX PRO V2 180 EU modules in set configuration

**HYDRAULIC DIAGRAM: VICTRIX PRO V2 EU WITH 1 DIRECT ZONE
1 MIXED ZONE AND 1 DHW ZONE**

KEY:
 B1 Common flow probe
 B2 Storage tank probe
 B3-2 System flow probe zone 2
 B4 External probe
 M3 DHW pump
 M4 Domestic hot water recirculation pump
 M10-1 Zone 1 booster pump
 M10-2 Zone 2 booster pump
 M31-2 Zone 2 mixing valve
 S20-1 Zone 1 room chrono-thermostat
 S20-2 Zone 2 room chrono-thermostat
 C VICTRIX PRO V20 EU boiler
 NC Condensate neutraliser
 SP Plate heat exchanger
 UB Storage tank unit

NOTES:

- > remember to install the condensate drain circuits
- > this diagram is an example
- > check the instruction booklets for the set up of the hydraulic and electric connections
- > and for the cross-section of the cables
- > check the instruction booklets for positioning of the components and maximum allowable distances for temperature control, potential-free contact thermostats or ones provided with OPENTHERM communication protocol can be used

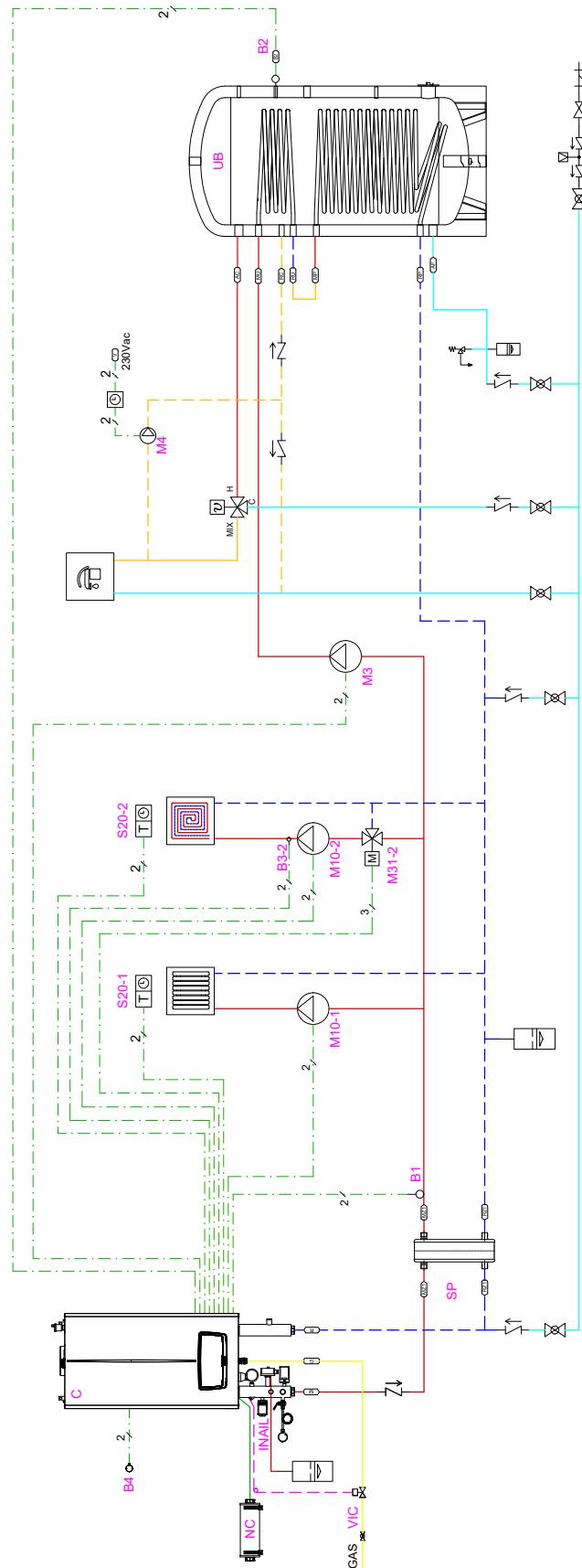

NOTE: The diagram provided here is indicative, see notes on the back of the cover

VICTRIX PRO V2 EU

36

HYDRAULIC DIAGRAM: VICTRIX PRO V2 EU WITH 1 DIRECT ZONE 1 MIXED ZONE AND 3-WAY VALVE WITH DHW PRIORITY

NOTES:

- > remember to install the condensate drain circuits
- > this diagram is an example
- > check the instruction booklets for the set up of the hydraulic and electric connections
- > and for the cross-section of the cables
- > check the instruction booklets for positioning of the components and maximum allowable distances

- KEY:**
- B1 Common flow probe
 - B2 Storage tank probe
 - B3-2 System flow probe zone 2
 - B4 External probe
 - M4 DHW pump
 - M10-1 Domestic hot water recirculation pump
 - M10-2 Zone 1 booster pump
 - M30 Zone 2 booster pump
 - M31-2 Zone 2 mixing valve
 - S20-1 Zone 1 room chrono-thermostat
 - S20-2 Zone 2 room chrono-thermostat
 - C VICTRIX PRO V20 EU boiler
 - NC Condensate neutraliser
 - SP Plate heat exchanger
 - UB Storage tank unit

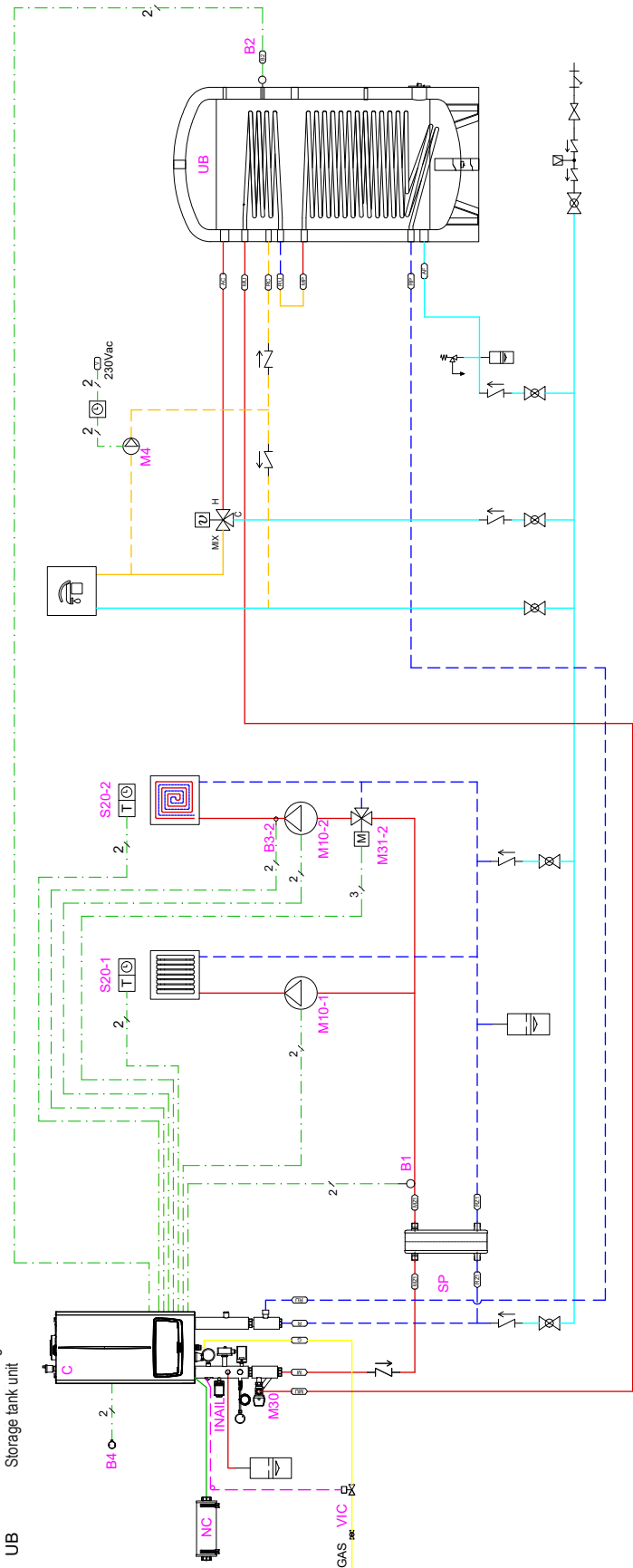

NOTE: The diagram provided here is indicative, see notes on the back of the cover

37

HYDRAULIC DIAGRAM: VICTRIX PRO V2 EU IN SIMPLE CASCADE WITH 1 DIRECT ZONE 1 MIXED ZONE AND 1 DHW ZONE

KEY:
 B1 Storage tank probe
 B2 System flow probe zone 2
 B3-2 External probe
 B4 DHW pump
 M3 Domestic hot water recirculation pump
 M4 Zone 1 booster pump
 M10-1 Zone 2 booster pump
 M10-2 Zone 2 mixing valve
 S20-1 Zone 1 room chrono-thermostat
 S20-2 Zone 2 room chrono-thermostat
 C VICTRIX PRO V20 EU boiler
 NC Condensate neutraliser
 SP Plate heat exchanger
 UB Boiler unit

NOTES:

- > remember to install the condensate drain circuits
- > this diagram is an example
- > check the instruction booklets for the set up of the hydraulic and electric connections
- > and for the cross-section of the cables
- > check the instruction booklets for positioning of the components and maximum allowable distances for temperature control, potential-free contact thermostats or ones provided with OPENTHERM communication protocol can be used

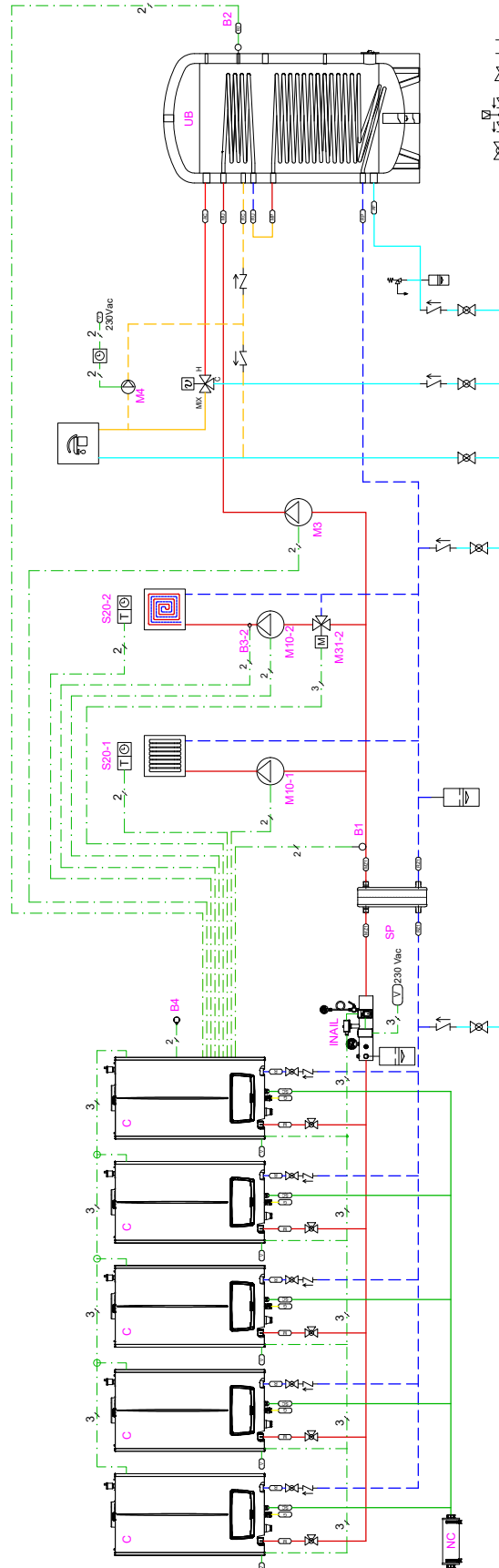

NOTE: The diagram provided here is indicative, see notes on the back of the cover

VICTRIX PRO V2 EU

38 HYDRAULIC DIAGRAM: VICTRIX PRO V2 EU IN SET CONFIGURATION WITH CASCADE AND ZONE REGULATOR + EXPANSION WITH 1 DIRECT ZONE 3 MIXED ZONES AND 1 DHW ZONE

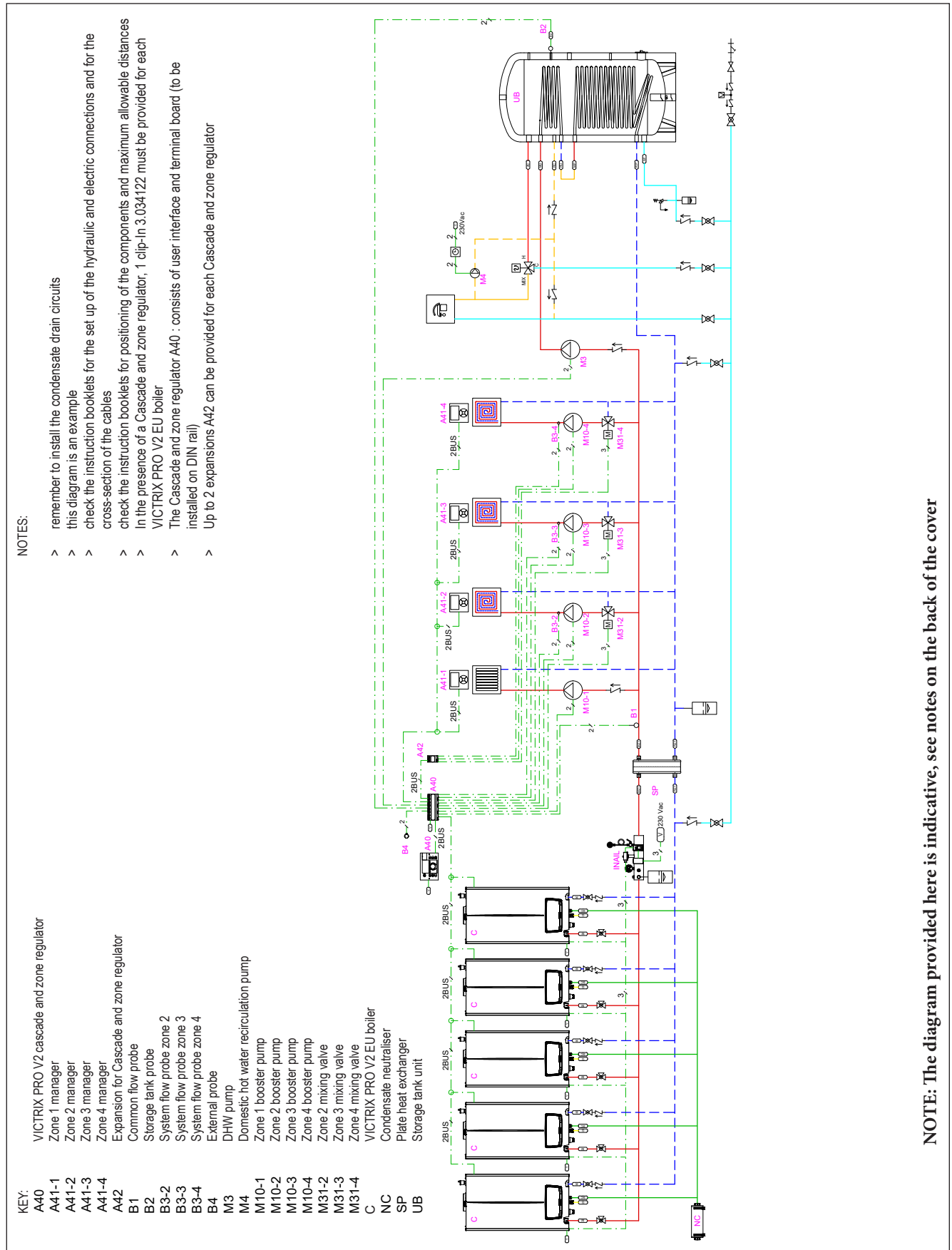

39 HYDRAULIC DIAGRAM: 3 VICTRIX PRO V2 EU WITH CABINET IN SIMPLE CASCADE WITH 1 DIRECT ZONE 1 MIXED ZONE AND 1 DHW ZONE

- NOTES:**
- > remember to install the condensate drain circuits this functional diagram is an example
 - > check the instruction booklets for the set up of the hydraulic and electric connections and for the cross-section of the cables
 - > check the instruction booklets for positioning of the components and maximum allowable distances for temperature control, potential-free contact thermostats or ones provided with OPENTHERM communication protocol can be used

- KEY:**
- B1 Common flow probe
 - B2 Storage tank probe
 - B3-2 System flow probe zone 2
 - B4 External probe
 - M3 DHW pump
 - M4 Domestic hot water recirculation pump
 - M10-1 Zone 1 booster pump
 - M10-2 Zone 2 booster pump
 - M31-2 Zone 2 mixing valve
 - S20-1 Zone 1 room chrono-thermostat
 - S20-2 Zone 2 room chrono-thermostat
 - C VICTRIX PRO V2 EU boiler in cabinet with manifold and safety devices
 - SP Plate heat exchanger
 - UB Storage tank unit

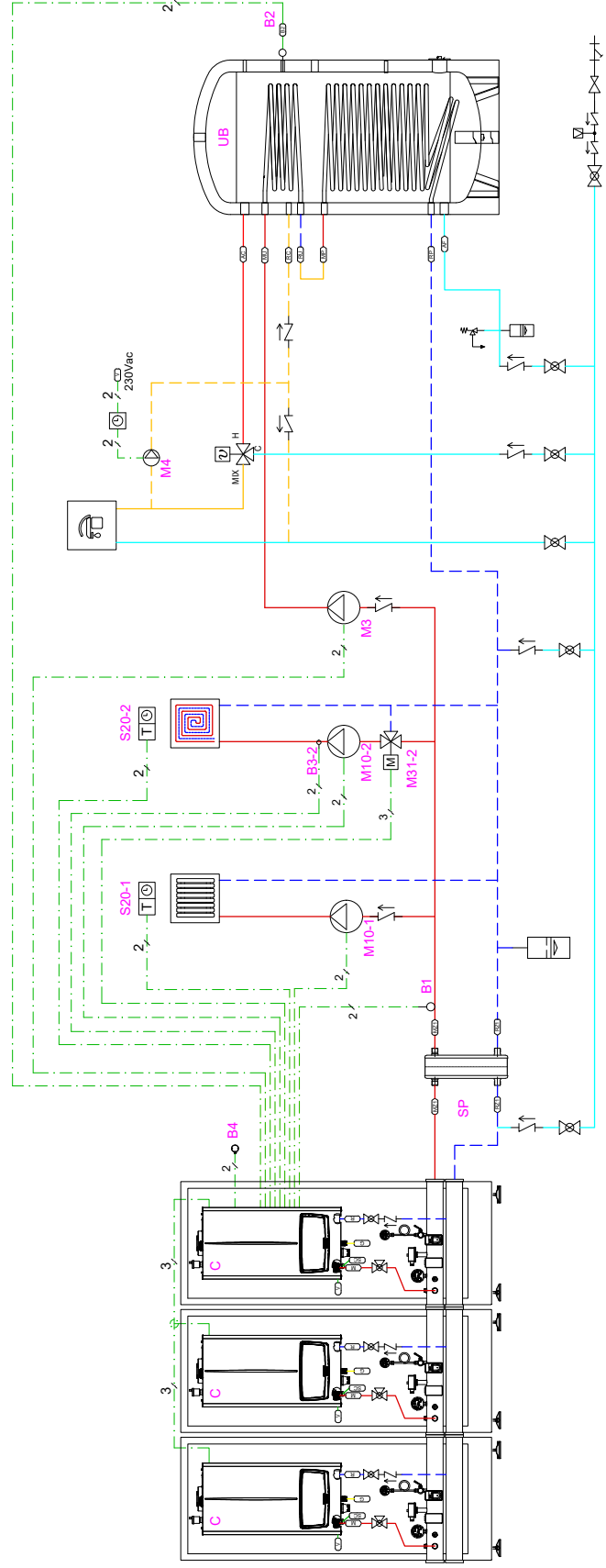

NOTE: The diagram provided here is indicative, see notes on the back of the cover

During the useful life of the products, performance is affected by external factors, e.g. the hardness of the DHW, atmospheric agents, deposits in the system and so on.

The declared data refer to new products that are correctly installed and used in observance of the Standards in force.

N.B.: correct periodic maintenance is highly recommended.

NOTE: Depending on the specific design and installation conditions, the diagrams and drawings provided in this documentation can require further integration or modifications, according to what is set forth by the Standards and technical regulations in force and applicable (as an example, the R stamp - edition 2009 is mentioned). It is the professional's responsibility to identify the applicable provisions, to evaluate compliance with these in each case and the necessity of any changes to diagrams and drawings.



immergas.com



To request further specific details, sector Professionals can also use the following e-mail address:
consulenza@immergas.com

Immergas S.p.A.
42041 Brescello (RE) - Italy
Tel. 0522.689011
Fax 0522.680617



IMMERGAS
QUALITY SYSTEM
CERTIFIED
UNI EN ISO 9001:2015

Design, manufacture and after-sales assistance of gas boilers, gas water heaters and relative accessories

