

EUREKA

Factory-made hybrid system

- EUREKA MONO 9/26
- EUREKA MONO 12/26
- EUREKA DUAL 18/26
- EUREKA TRIAL 27/26
- EUREKA MONO 9/35
- EUREKA MONO 12/35
- EUREKA DUAL 18/35
- EUREKA TRIAL 27/35

AL **IE**

Instructions and recommendations

Installer

User

Maintenance technician

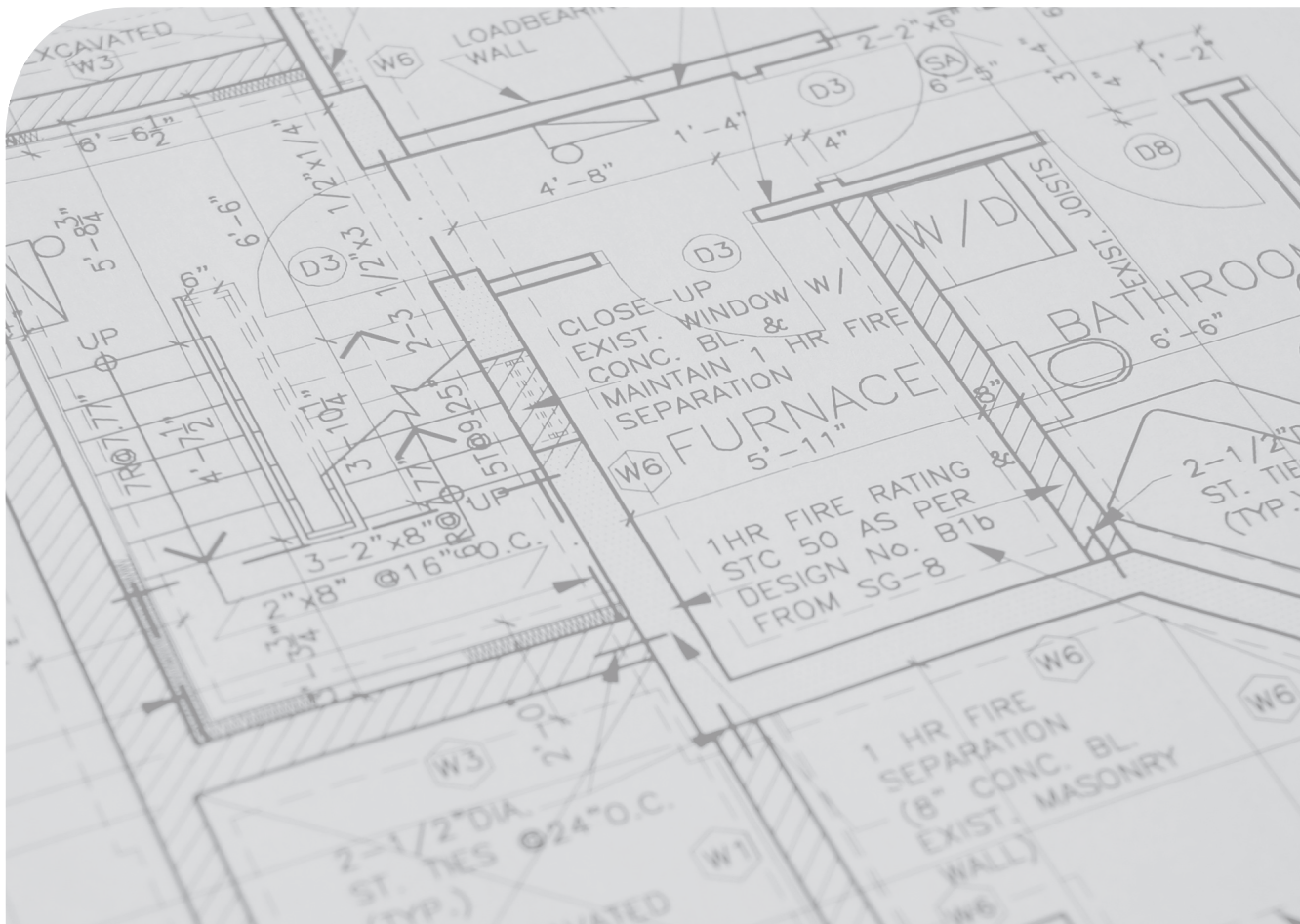

INDEX

Dear Customer.....	4
General Recommendations.....	5
Safety symbols used.....	6
Personal protective equipment	6
1 Unit installation	7
1.1 Installation warnings	7
1.2 Product specifications	9
1.2.1 System description.....	9
1.2.2 Product supply.....	10
1.2.3 Product range	11
1.2.4 Accessories.....	11
1.2.5 Possible combinations between EUREKA packages and UI THOR indoor units.	12
1.3 Configuration plate.....	13
1.3.1 Configuration plate positioning.....	13
1.3.2 Configuration plate example	13
1.4 Handling the appliance	14
1.4.1 Handling the crate.....	14
1.4.2 Handling with hoist or similar.....	14
1.4.3 Handling with forklift truck or similar (e.g.: pallet truck)	14
1.5 System installation.....	15
1.5.1 Installation requirements and preparation of the installation site	16
1.5.2 Minimum installation distances.....	16
1.6 Electrical connection.....	17
1.7 Temperature control setting	17
1.8 Installation of the interface board on the air conditioning indoor unit (UI Clim)	18
1.9 System start-up (ignition).....	22
1.10 System wiring diagram.....	23
1.11 Typical installation examples	24
1.11.1 EUREKA MONO installation diagram with room thermostat + DOMINUS V2.....	25
1.11.2 DUAL + 2 zones installation diagram with zone valves (1 Remote Panel + 1 RT)	28
1.11.3 TRIAL installation diagram + 3 zones with booster circulators (1STR. With Wireless Probe + 2 MIX. With RT)	31
1.11.4 EUREKA TRIAL + DIM A/2BT installation diagram (1 Str. + 1 Mix. with 3 splits + 1 Mix.) with Remote Panels	34
2 User Instructions	37
2.1 Use of the remote control and the "Clima Smart" app	39
2.2 Setting the request hysteresis	39
2.3 Setting the "Hybrid system" menu.....	40
2.3.1 C.H.....	40
2.3.1.1 Possible settings of parameter "Hybrid CH Syst. Mode"	40
2.3.1.2 Description of the "Setting Advanced" menu	44
2.3.2 Cooling.....	45
2.3.3 Room setpoint settings (AUTO/MAN setting)	46
2.4 Permanent shutdown.....	46



3 Maintenance and service 47

3.1 Implementing..... 47

3.2 First ignition parameter setting..... 47

 3.2.1 Hybrid system definition..... 47

 3.2.2 “UICLIM” configuration..... 48

 3.2.3 Definition “Hybrid Cool. Syst. Mode/ Hybrid CH Syst. Mode” 48

3.3 Thermoregulation device configuration 49

 3.3.1 Remote zone control 49

 3.3.2 Wireless room probe 50

 3.3.3 Dominus 50

Dear Customer

Congratulations for having chosen a top-quality Immergas product, able to assure well-being and safety for a long period of time. As an Immergas customer you can also count on a Qualified Authorised After-Sales Technical Assistance Centre, prepared and updated to guarantee the constant efficiency of your products. Read the following pages carefully: you will be able to draw useful tips on the proper use of the device, compliance with which will confirm your satisfaction with the Immergas product.

For assistance and routine maintenance, contact Authorised Technical Service Centres: they have original spare parts and are specifically trained directly by the manufacturer.

Thermal systems must undergo periodic maintenance and scheduled checks of the energy efficiency in compliance with national, regional or local provisions in force.

Thermal systems must undergo periodic maintenance and scheduled checks of the energy efficiency in compliance with national, regional or local provisions in force. In order to fulfil the obligations set forth by the Law, we urge you to contact the Authorised Technical Assistance Centres, which will illustrate to you the advantages of the Formula Comfort operation.

The company **IMMERGAS S.p.A.**, with registered office in via Cisa Ligure 95 42041 Brescello (RE), declares that the design, manufacturing and after-sales assistance processes comply with the requirements of standard **UNIEN ISO 9001:2015**.

For further details on the product CE marking, request a copy of the Declaration of Conformity from the manufacturer, specifying the appliance model and the language of the country.

The manufacturer declines all liability due to printing or transcription errors, reserving the right to make any modifications to its technical and commercial documents without forewarning.

Correct disposal of the product (electrical and electronic waste) (Applicable in countries with separate waste collection systems)



The symbol on the product, on the accessories or on the documentation (a crossed-out wheeled waste bin with a black stripe below) indicates that the product and relative electronic accessories must not be disposed of with unsorted municipal waste at the end of its life cycle but must be collected separately to allow for reuse, recycling and other forms of recovery in compliance with standards in force. In fact waste electric and electronic equipment may contain harmful and hazardous substances which, if not managed properly, pose a hazard for the environment and human health.

At the end of its service life, the appliance must not be disposed of like normal household waste nor released in the environment but must be removed by a professionally authorised company as required by current legislation and handed over to authorised collection systems according to local standards.



GENERAL RECOMMENDATIONS

Before carrying out any type of work on the appliance, personnel in charge of installation/maintenance must refer to the information in this manual.

This book contains important information for the:

Installer (section 1, section 3 and section 5);

User (section 2 and section 3);

Maintenance technician (section 3, section 4 and section 5).

- This manual provides a detailed explanation on the precautions to be taken during use.
- Read this manual carefully before using the control unit to guarantee its proper operation.
- After you have read this manual, keep it for future consultation.
- The user must carefully read the instructions in the specific section (section 2).
- The user must limit operations on the appliance only to those explicitly allowed in the specific section.
- The appliance must be installed by qualified and professionally trained personnel.
- The instruction booklet is an integral and essential part of the product and must be given to the new user in the case of transfer or succession of ownership.
- This manual must be stored with care and consulted carefully, as all of the warnings provide important safety indications for installation, use and maintenance stages.
- In compliance with legislation in force, the systems must be designed by qualified professionals. Installation and maintenance must be performed in compliance with the regulations in force, according to the manufacturer's instructions and by professionally qualified staff, intended as staff with specific technical skills in the system sector, as envisioned by the Law.
- Improper installation or assembly of the Immergas appliance and/or components, accessories, kit and devices can cause unexpected problems to people, animals and objects. Read the instructions provided with the product carefully to ensure proper installation.
- This instruction manual provides technical information for installing Immergas products. As for the other issues related to the installation of products (e.g. safety at the workplace, environmental protection, accident prevention), it is necessary to comply with the provisions of the standards in force and the principles of good practice.
- All the Immergas products are protected with suitable transport packaging.
- The material must be stored in a dry place protected from the weather.
- Damaged products must not be installed.
- Maintenance must be carried out by skilled technical staff. For example, the Authorised Service Centre that represents a guarantee of qualifications and professionalism.
- The appliance must only be destined for the use for which it has been expressly declared. Any other use will be considered improper and therefore potentially dangerous.
- If errors occur during installation, operation and maintenance, due to non-compliance with technical laws in force, standards or instructions contained in this booklet (or however supplied by the manufacturer), the manufacturer is excluded from any contractual and extra-contractual liability for any damages and the device warranty is invalidated.
- In the event of malfunctions, faults or incorrect operation, turn the appliance off and contact an authorised company (e.g. the Authorised Technical Assistance Centre, which has specifically trained staff and original spare parts). Do not attempt to modify or repair the appliance alone.
- For further information regarding legislative and statutory provisions relative to the installation of this system, consult the Immergas site at the following address: www.immergas.com



SAFETY SYMBOLS USED



GENERIC HAZARD

Strictly follow all of the indications next to the pictogram. Failure to follow the indications can generate hazard situations resulting in possible harm to the health of the operator and user in general, and/or property damage.



ELECTRICAL HAZARD

Strictly follow all of the indications next to the pictogram. The symbol indicates the appliance's electrical components or, in this manual, identifies actions that can cause an electrical hazard.



WARNING FOR INSTALLER

Read the instruction booklet carefully before installing the product.



COMBUSTIBLE MATERIAL WARNING

This symbol indicates that the appliance in question uses an A3 highly flammable refrigerant. There is a risk of fire if the refrigerant leaked or was exposed to an external ignition source.



WARNINGS

Strictly follow all of the indications next to the pictogram. Failure to follow the indications can generate hazard situations resulting in possible minor injuries to the health of both the operator and the user in general, and/or slight material damage.



ATTENTION

Read and understand the instructions of the appliance before carrying out any operation, carefully following the instructions given. Failure to observe the instructions may result in malfunction of the unit.



INFORMATION

Indicates useful tips or additional information.



EARTH TERMINAL CONNECTION

The symbol identifies the appliance's earth terminal connection point.



DISPOSAL WARNING

The user must not dispose of the appliance at the end of its service life as municipal waste, but send it to appropriate collection centres.

PERSONAL PROTECTIVE EQUIPMENT



SAFETY GLOVES



EYE PROTECTION



SAFETY FOOTWEAR



1 UNIT INSTALLATION

1.1 INSTALLATION WARNINGS



- All the materials supplied are essential for the safety of the appliance.



Make sure to follow the storage, installation and maintenance instructions.



- Disconnect the appliance from the power mains before servicing or accessing its internal components.



- You must read this manual carefully before installing the appliance, after which it must be put in a safe place readily available for consultation by the user.
- For safety purposes, the installer is required to carefully read the entire contents of this manual.



- The user must keep the manual in a safe place and remember to pass it on to any other user who over time may manage the appliance after him/her.
- The manual explains how to install the EUREKA system correctly.
- The manufacturer cannot be held liable for any damage resulting from the use of parts that are not compatible with those explicitly indicated as part of the system.
- The manufacturer disclaims all liability for damage resulting from changes made without their prior written authorisation and/or electric and/or hydraulic and/or cooling connection errors of the appliance. Failure to follow the instructions herein or using the appliance outside of the “Operating Limits” indicated shall immediately nullify any form of manufacturer’s warranty.
- Compliance with all the precautions, warnings and guidelines in this manual is essential to prevent serious damage to the system and personal injury.
- Failure to follow these instructions or the requirements indicated in the operating range set forth in the product specifications will immediately invalidate the warranty.
- The appliance must not be used if any damage or anomaly is noticed, such as the emission of odour or increased noise.



- Always stop the unit by switching off the power supply so as to prevent electric shock (electrocution), fire and injury. Contact the Immergas technical assistance if the unit produces smoke, if the power cable is hot or damaged or if the unit is very noisy.

- Always inspect the unit, electric connections, cooling pipes and protections at regular intervals.

All the inspections must only be carried out by qualified personnel.



- Packing materials (staples, nails, plastic bags, polystyrene foam, etc.) constitute a hazard and must be kept out of the reach of children.
- Do not have unauthorised personnel attempt to repair, move, modify or reinstall the unit. These operations can cause damage, electric shocks and fire.
- Do not place liquid containers or other objects on the unit. Never sit or stay on the product.



- All materials used for the packaging of this appliance are recyclable.
- The packaging material must be disposed of in compliance with standards in force.





- **The power supply line must be made as required by safety standards in force.**



- This appliance is not intended to be used by persons (including children younger than 8 years old) with reduced physical, sensory or mental capacities, or without experience and knowledge, unless they have been given instructions by a person in charge of their safety on the safe use of the appliance and of the hazards that it entails. Children must not play with the appliance. The appliance must not be cleaned and serviced by children without the supervision of an adult.



- **Make sure not to modify the power cable, to make extensions or connections with several wires.**
 - **Low-quality connections or insulation, or exceeding the current limit, could cause shocks and fire.**



- Do not use any means to speed up the defrosting operation or to clean other than those recommended by Immergas.



- Keep in mind that refrigerants are not odourised.



- Determine the installation site taking into account the normative references and the conditions mentioned in this installation, use and maintenance manual.



- The appliance must not be installed and transported resting on one side or upside down as oil could leak from the compressor and enter the cooling circuit thus seriously damaging the appliance.



- Make sure to safely dispose of the material making up the packaging. Packaging material, such as nails and other metal or wooden pallets can cause injuries to persons and animals if disposed of in an unsafe manner.



1.2 PRODUCT SPECIFICATIONS

1.2.1 System description

The Factory made EUREKA hybrid system consists of:

- Boiler (hereinafter referred to as “UCIEUREKA”).
- Multisplit air/air system:
- Air conditioning indoor unit(s) (hereinafter referred to as “UI Clim”) (to be purchased separately);
- Air conditioning outdoor unit(s) (hereinafter referred to as “UE Clim”).
- Multifunction board (hereinafter referred to as “Interface Board”). The number of Interface Boards must correspond to the number of “UI Clim” to be installed. One “Interface Board” must be installed for each “UI Clim”.
- 8 W - 12 V power supply device (hereinafter referred to as “Power supply device”).
- Thor Wireless Kit. The number of kits must correspond to the number of “UI Clim” to be installed. One “Wireless kit” must be installed for each “UI Clim”.
- External probe.

The system is controlled by “UCIEUREKA” which, depending on climatic conditions and user preferences, will give priority to one of the available generators (in heating mode).

In certain conditions, one of the generators may be active simultaneously or exclusively.

The management of the air conditioning units will therefore be integrated, while still allowing the use of the IR remote control.

It is possible to choose whether to enable the integration and control of the air conditioning units for both heating and cooling.

The hybrid system **does NOT manage “air only” zones**, so any air conditioning units that cannot be combined with hydraulic zones must be managed via IR remote control.



1.2.2 Product supply.

Key (Fig. 1):

- A - Boiler ("UCIEUREKA")
- B - PDC outdoor unit (UECLIM)
- C - Accessory box
- D - Envelope with instruction booklet

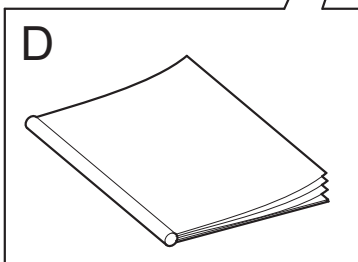
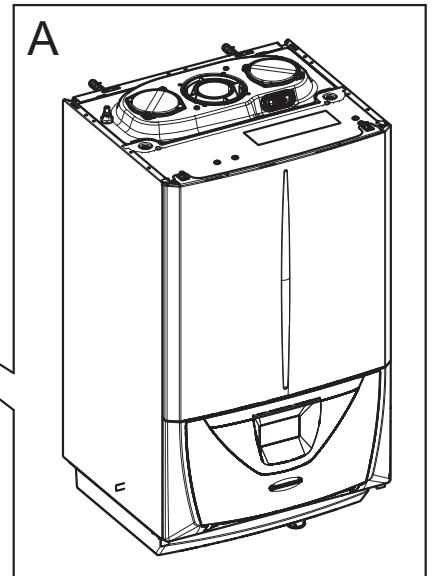
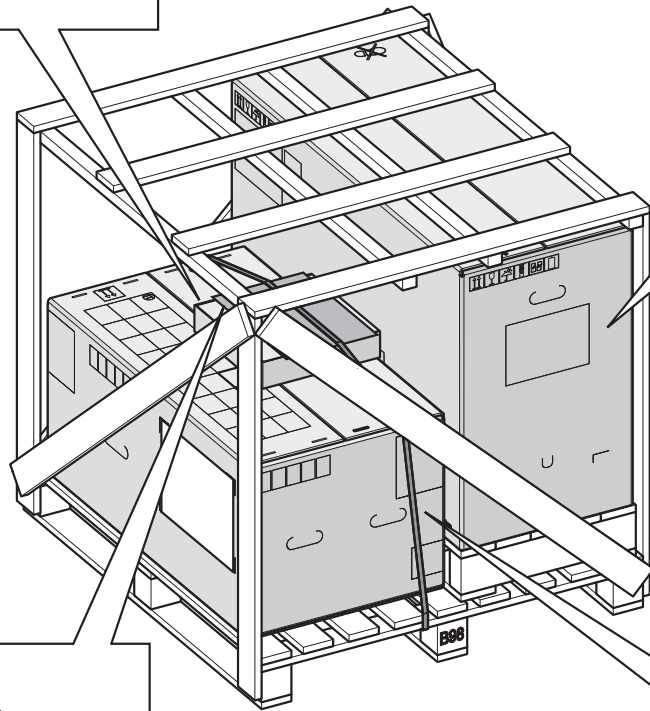
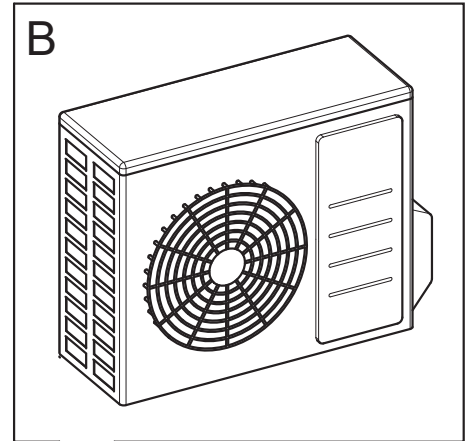
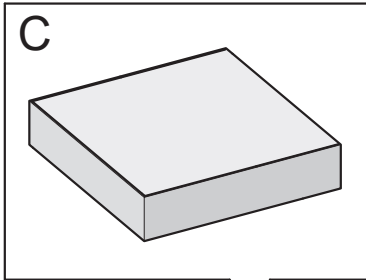



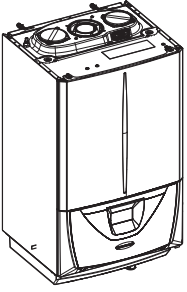
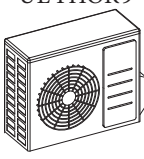
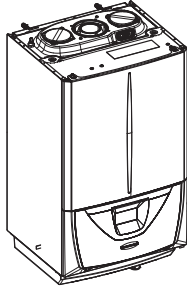
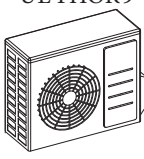
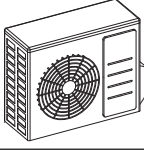
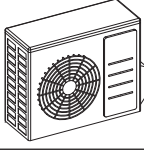
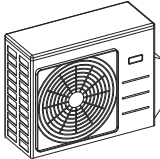
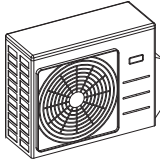
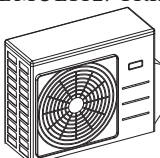
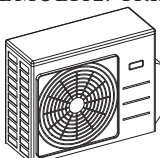





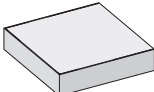
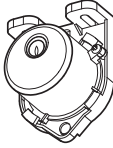
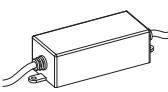

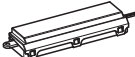

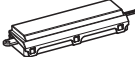
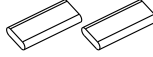
1.2.3 Product range

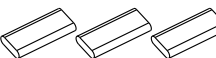
Modelname	Appliance (A)	PDC outdoor unit (B)	Modelname	Appliance (A)	PDC outdoor unit (B)
EUREKA MONO 9/26		UETHOR 9 	EUREKA MONO 9/35		UETHOR 9 
EUREKA MONO 12/26		UETHOR 12 	EUREKA MONO 12/35		UETHOR 12 
EUREKA DUAL 18/26		UEMULTI 18 DUAL 	EUREKA DUAL 18/35		UEMULTI 18 DUAL 
EUREKA TRIAL 27/26		UEMULTI 27 TRIAL 	EUREKA TRIAL 27/35		UEMULTI 27 TRIAL 

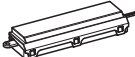
1.2.4 Accessories

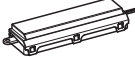
- The accessories supplied must be kept at hand during installation.
- At the end of the work, the Installation Manual must be handed over to the customer. This must be kept throughout the entire lifetime of the appliance as it is an integral part thereof and must be available to bodies in charge of controlling winter heating and summer air-conditioning systems.

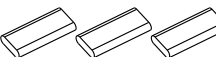
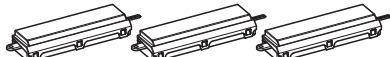
Model name	Accessory box (C)	External probe	Power supply device	Wi-Fikit	Interface boards
EUREKA MONO 9/26					
EUREKA MONO 12/26					
EUREKA DUAL 18/26					
EUREKA TRIAL 27/26					
EUREKA MONO 9/35					
EUREKA MONO 12/35					
EUREKA DUAL 18/35					
EUREKA TRIAL 27/35					

INSTALLER

USER

MAINTENANCE TECHNICIAN

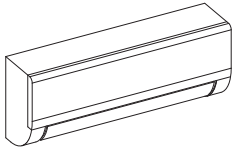

1.2.5 Possible combinations between EUREKA packages and UI THOR indoor units.

Model name	Number of UI THOR indoor units	Power of UI THOR indoor units				
						
EUREKA MONO 9/26	1	9				
EUREKA MONO 9/35						
EUREKA MONO 12/26		12				
EUREKA MONO 12/35						
EUREKA DUAL 18/26	2	9+9	9+12	9+18	12+12	12+18
EUREKA DUAL 18/35						
EUREKA TRIAL 27/26	2	9+9	9+12	9+18	12+12	12+18
EUREKA TRIAL 27/35	3	9+9+9	9+9+12	9+9+18	9+12+12	12+12+12

1.3 CONFIGURATION PLATE

1.3.1 Configuration plate positioning

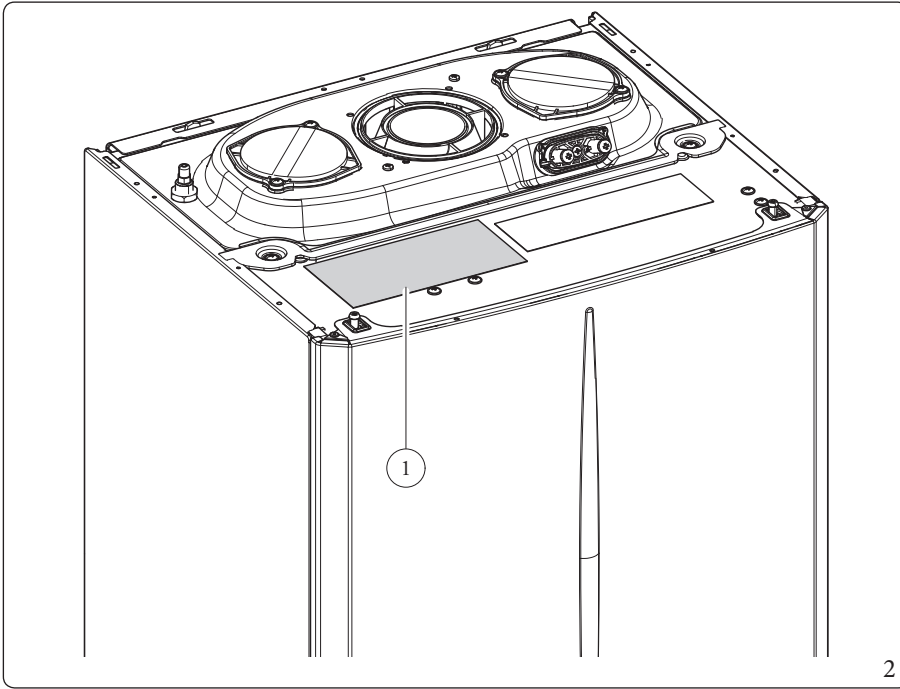

Key (Fig. 2):

1 - Configuration plate

1.3.2 Configuration plate example

<input type="checkbox"/> EUREKA MONO 9/26 (UCI EUREKA 26 + UE THOR 9)	<input type="checkbox"/> EUREKA MONO 9/35 (UCI EUREKA 35 + UE THOR 9)
<input type="checkbox"/> EUREKA MONO 12/26 (UCI EUREKA 26 + UE THOR 12)	<input type="checkbox"/> EUREKA MONO 12/35 (UCI EUREKA 35 + UE THOR 12)
<input type="checkbox"/> EUREKA DUAL 18/26 (UCI EUREKA 26 + UE MULTI 18 DUAL)	<input type="checkbox"/> EUREKA DUAL 18/35 (UCI EUREKA 35 + UE MULTI 18 DUAL)
<input type="checkbox"/> EUREKA TRIAL 27/26 (UCI EUREKA 26 + UE MULTI 27 TRIAL)	<input type="checkbox"/> EUREKA TRIAL 27/35 (UCI EUREKA 35 + UE MULTI 27 TRIAL)
<input type="checkbox"/> UI THOR 9 Q.ty <input type="checkbox"/> 1 <input type="checkbox"/> 2 <input type="checkbox"/> 3	<input type="checkbox"/> UI THOR 12 Q.ty <input type="checkbox"/> 1 <input type="checkbox"/> 2 <input type="checkbox"/> 3
<input type="checkbox"/> UI THOR 18 Q.ty <input type="checkbox"/> 1	

1.051514



At the end of installation, use a permanent marker to mark the configuration label with the combination of outdoor climate unit + indoor climate unit + indoor boiler unit installed.

INSTALLER

USER

MAINTENANCE TECHNICIAN



1.4 HANDLING THE APPLIANCE

- Make sure that the movement path is safe, assessing the weight of the system in advance.
- During transport, do not incline the product beyond 30° (always keeping the unit upright).
- Be careful not to suffer injuries when handling and installing it.
- Wear personal protective equipment (gloves, etc.).

1.4.1 Handling the crate



- The system must be checked immediately upon delivery (for any damage during transport). Any damage must be reported immediately to the Immergas's product dealer. After inspection, the protective wrapping and case must be reassembled properly so that they protect the product.
- It is important to protect the product which must therefore be transported in protective packaging so as to be kept covered until final installation.

1.4.2 Handling with hoist or similar

- Lift the product with a hoist using approved lifting straps (in compliance with standards in force). Keep the straps long so as not to damage the panels. When lifting with a hoist, always wear personal protective equipment (safety helmet, accident prevention shoes and gloves).

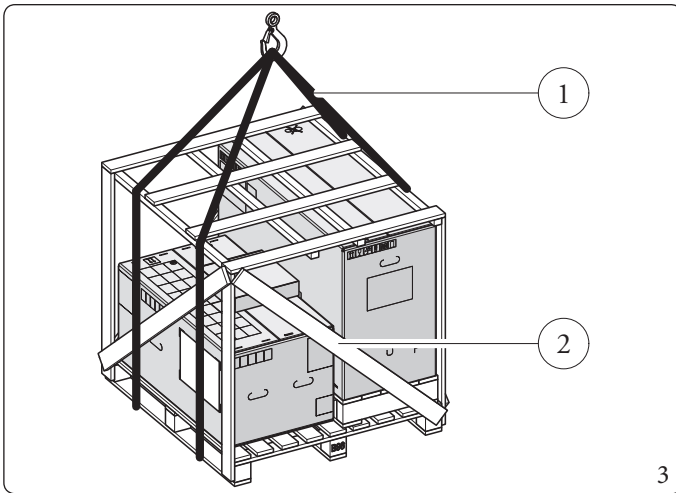

Key (Fig. 3):

- 1 - Lifting straps
- 2 - Hybrid system with packaging

1.4.3 Handling with forklift truck or similar (e.g.: pallet truck)

- Carefully insert the forks of the truck in the pallet positioned at the bottom of the appliance. Be careful that the forks do not damage the system.

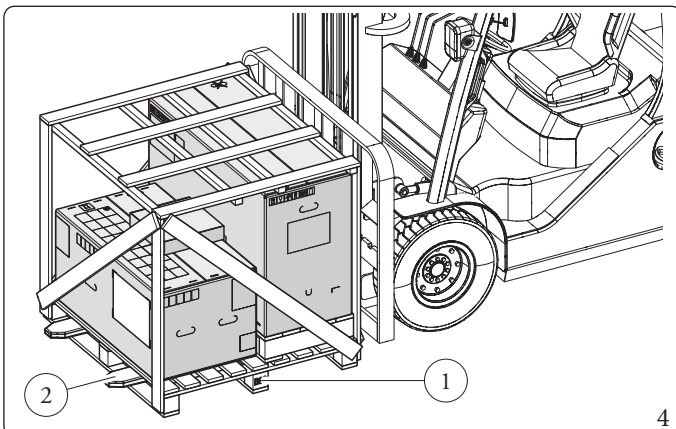

Key (Fig. 4):

- 1 - Pallet
- 2 - Forklift truck forks or similar (e.g.: pallet truck)

1.5 SYSTEM INSTALLATION



For the system installation, refer to the instruction booklets:

- of the boiler (UCIEUREKA);
- of the outdoor and indoor air conditioning units (for “UE Clim”: instruction booklet of “UEMULTI” or “UETHOR”; for “UI Clim”: instruction booklet of “UITHOR”).

The EUREKA system is considered to be fully functional only if the components indicated in paragraph 1.2.1 (including separately purchased “UI Clim”) are correctly powered and connected to each other.

List of hydraulic and refrigeration connections required for the correct operation of the EUREKA system:

- “UCIEUREKA” is connected hydraulically only and exclusively to the water system for winter air conditioning and for the production of domestic hot water for domestic and similar uses.
- The “UE Clim” and the “UI Clim” are connected to each other by pipes, forming the refrigeration circuit of a single-phase reversible inverter air-to-air heat pump with direct expansion for winter and summer air conditioning. In the case of a single split installation, the outdoor unit is uniquely connected to the indoor unit, while in the case of a multisplit installation, several indoor units are connected to a single outdoor unit.

List of minimum electrical connections required for the correct operation of the EUREKA system:

- “UCIEUREKA” is electrically connected on the dashboard with signal cables to each interface board available in the system (one connection is required for each interface board).
- Each “UI Clim” provided in the system is electrically connected to an interface board. For more details, refer to the instruction booklet (UITHOR).
- Each interface board is connected to the power supply device with power cables.
- The “UE Clim” and the “UI Clim” must also be electrically connected to each other with signal and power cables for the air-to-air heat pump part of the EUREKA system to function correctly.

For more information on all possible additional electrical connections for the EUREKA system, refer to paragraph 1.6 of this instruction booklet.

The EUREKA system only works if the external probe is connected to the UCIEUREKA dashboard.

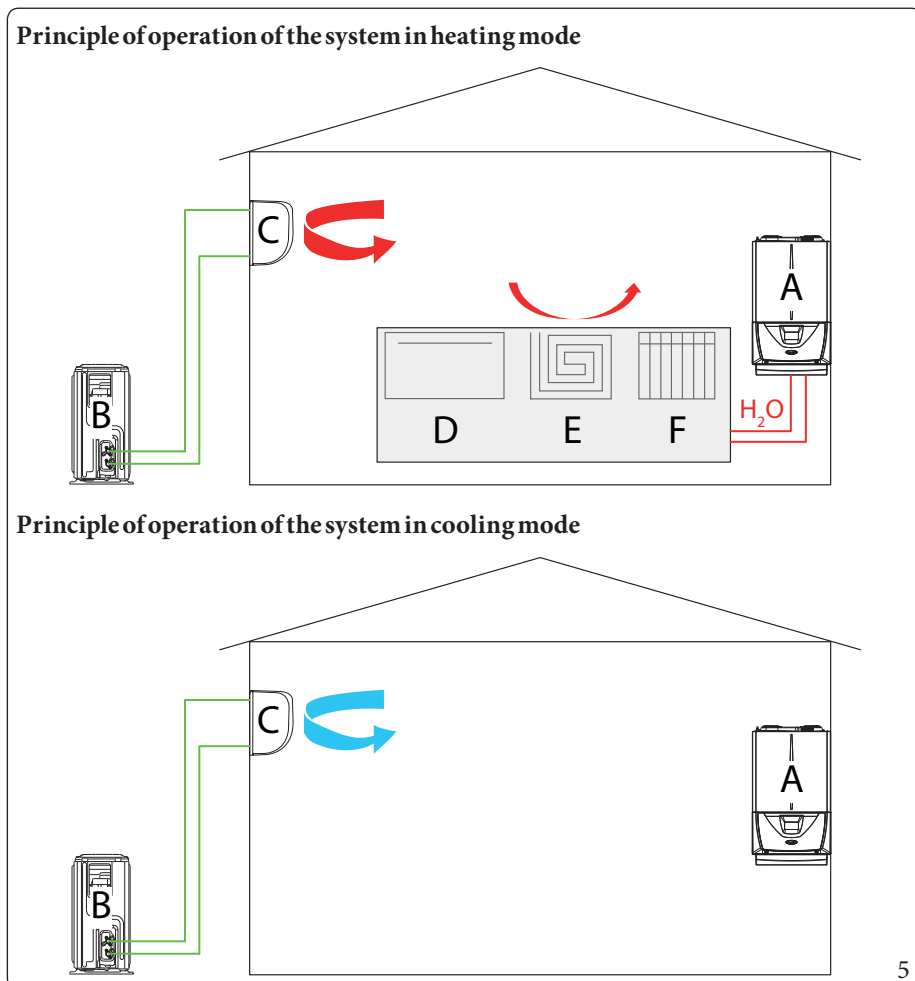

Key (Fig. 5):

- A - Boiler (“UCIEUREKA”)
- B - PDC outdoor unit (UE Clim)
- C - Indoor unit (UI Clim)
- D - Fancoil
- E - Radiant panels
- F - Radiators



1.5.1 Installation requirements and preparation of the installation site

The EUREKA system is installed both outdoors and indoors, specifically:

- UCIEUREKA can be installed indoors or outdoors in a partially protected area. By partially protected area, we mean one in which the unit is not directly exposed to the elements (rain, snow, hail, etc.).
- UE Clim can be installed on the floor or wall, on special brackets or supports (sold separately).
- UI Clim must be installed indoors, on a wall of the room to be air-conditioned.

Ensure that the minimum installation distances for all the main parts of the EUREKA system are respected (refer to the instruction booklet for the boiler (UCI EUREKA) and the air conditioning indoor and outdoor unit (UI THOR)), in order to allow and facilitate maintenance operations.



- During unpacking, handling and installation operations, operators must wear safety gloves so as not to be wounded on the edges of the appliance.
- During installation and maintenance operations, operators must wear ESD (electrostatic discharge) protective equipment.
- If installation/repair technicians are not supplied with protective equipment, they could be at the risk of injuries.

List of the main requirements for “UE Clim”; for a more detailed list, refer to the relevant instruction booklet (UE THOR):

- The unit must not be walked on and no materials of any kind may be placed on top of it.
- Do not install the unit or parts of it on stairs, landings or other elements constituting escape routes, thereby obstructing the free passage.
- Do not install near sources of heat.
- The unit must be positioned in such a way as to avoid refrigerant leaks in homes or otherwise endangering people, animals, property and possessions. In the event of a leak, the refrigerant must not be able to flow into ventilation openings, doors, hatches, drains or other openings.
- Do not position in basement windows or similar environments.
- Avoid obstacles or barriers that cause recirculation of exhaust air.
- If the outdoor unit is installed in a place exposed to the void (e.g. balcony), make sure that its positioning cannot cause damage to persons, animals or property.

List of the main requirements for “UI Clim”; for a more detailed list, refer to the relevant instruction booklet (UI THOR):

- The room where the indoor unit is installed must comply with the minimum surface area requirements in relation to the amount of refrigerant in the refrigeration circuit; for more information, refer to the paragraph “Refrigeration pipe connections” in the relevant instruction manual for the indoor unit.

1.5.2 Minimum installation distances



For minimum installation distances, refer to the instruction manual for the boiler (UCI EUREKA) and the air conditioning indoor and outdoor unit (UI THOR).



1.6 ELECTRICAL CONNECTION

For the electrical connection of the system, refer to the instruction manuals:

- Boiler (UCIEUREKA)
- Air conditioning indoor and outdoor unit (for "UE Clim", refer to the instruction manual for "UE Multi" or "UE Thor"; for "UI Clim", refer to the instruction booklet for "UI Thor").

See also paragraph 1.8 "Installation of the interface board on the air conditioning indoor unit (UI Clim)" for the assembly and electrical connection of the interface board.



The power supply unit included in the kit must be mounted inside an inaccessible place.



Pay particular attention to the installation of extra-low voltage cables, as they must be adequately separated from low voltage cables (230 Vac).



- To connect the Modbus, use a twisted-pair Modbus/RS-485 cable, possibly shielded, with a characteristic impedance of 120 Ω .
- To connect the power supply unit to the interface card, you can use additional pairs of the same cable used for Modbus/RS-485.



- **In case of joint installation with low voltage cables (230 Vac), use a shielded twisted-pair Modbus/RS-485 cable, with a characteristic impedance of 120 Ω and a minimum nominal voltage of 450/750 V.**
- **In the case of joint installation with low voltage cables (230 Vac), for the connection between the power supply unit and the interface card it is possible to use additional pairs of the cable used for Modbus/RS-485 (minimum nominal voltage of 450/750 V), or a separate cable with the same minimum nominal voltage (450/750 V).**



The power supply must be connected to a 230Vac / 50Hz network in compliance with current regulations on electrical installations, in any case providing an omnipolar disconnection device with overvoltage category class III.



Bring the power supply unit and Modbus cables to the "UI Clim", making sure to maintain a minimum cable length outside the wall of 1 m.

1.7 TEMPERATURE CONTROL SETTING



For more information on the thermoregulation settings of the hydraulic system, refer to the paragraph "Thermoregulation Settings" in the boiler instruction booklet (UCIEUREKA).



1.8 INSTALLATION OF THE INTERFACE BOARD ON THE AIR CONDITIONING INDOOR UNIT (UICLIM)

Before installing the interface card, the “arrow” on the rotary switch (1, Fig. 6) must be set to a position that is:

- other than “0”;
- unique, i.e. choose different values for each "UI Clim", it is recommended to match the interface card with the address "A" to the "UI Clim A", the interface card with the address "B" to the "UI Clim B" and the interface card with the address "C" to the "UI Clim C".



At the end of the adjustment, make sure to note the set position as it is necessary to complete the configuration via the control panel.

Appliance	UI Clim address / switch position (Custom value)
IUACA	
IUACB	
IUACC	

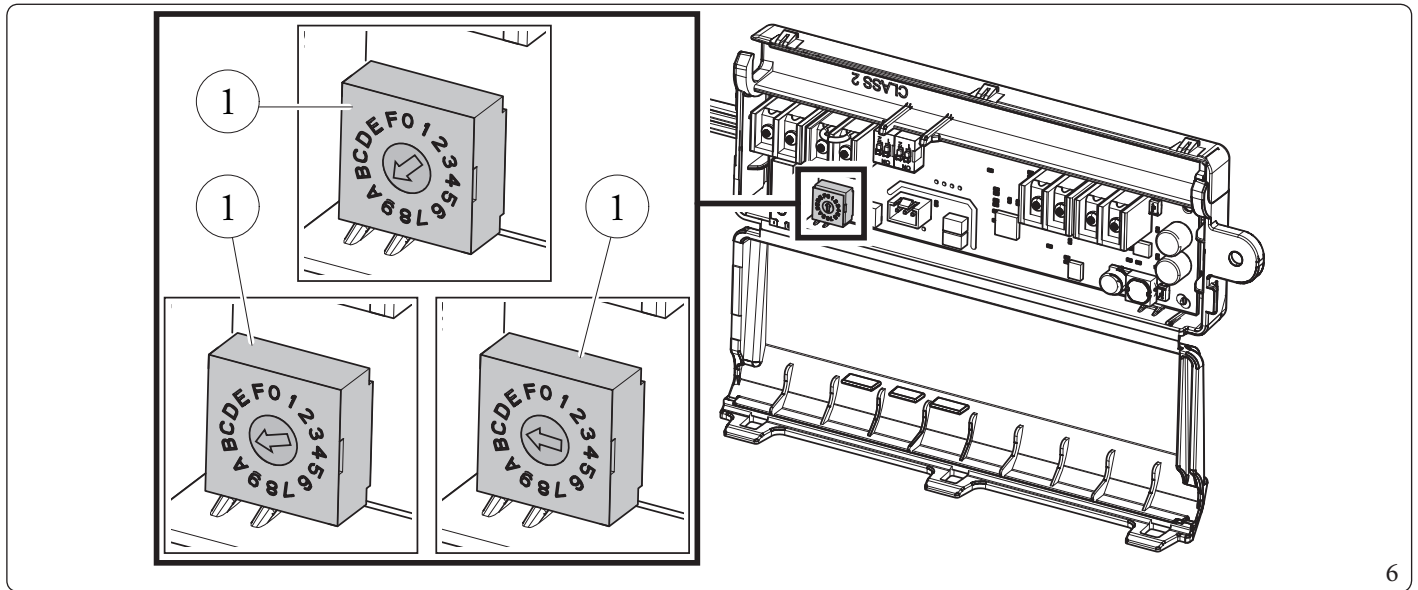

6

1. Close the cover of the interface board, insert the pin (2, Fig. 7) into its seat on the UI CLIM and tighten the screw provided (3, Fig. 7) without tightening it completely.

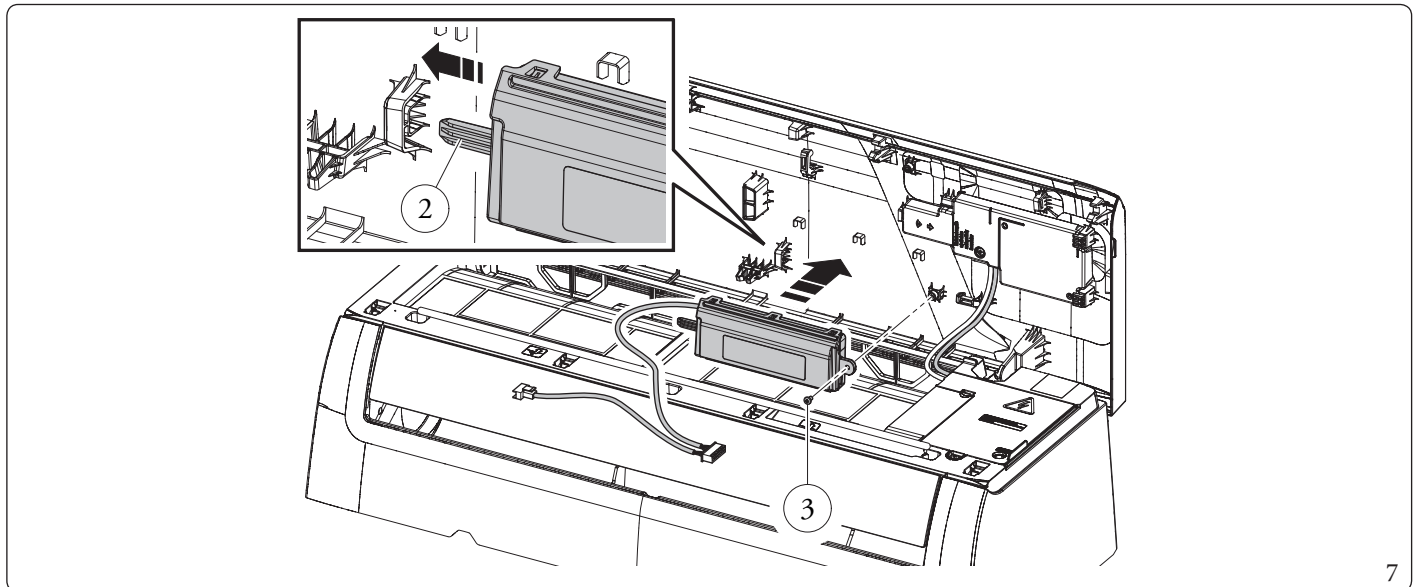

7

2. Loosen the screw (4, Fig. 8) and remove the connection compartment cover (5, Fig. 8) from its seat.

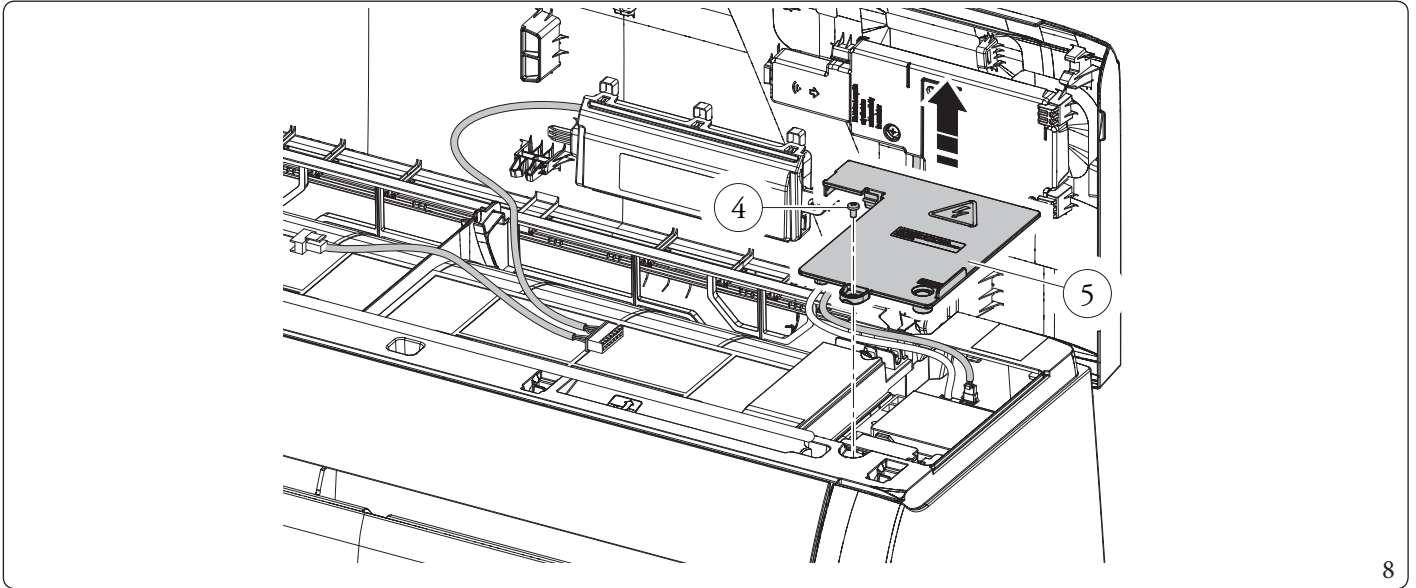

3. Disconnect the cable (6, Fig. 9) of the display board (7, Fig. 9) from the connector (8, Fig. 9).

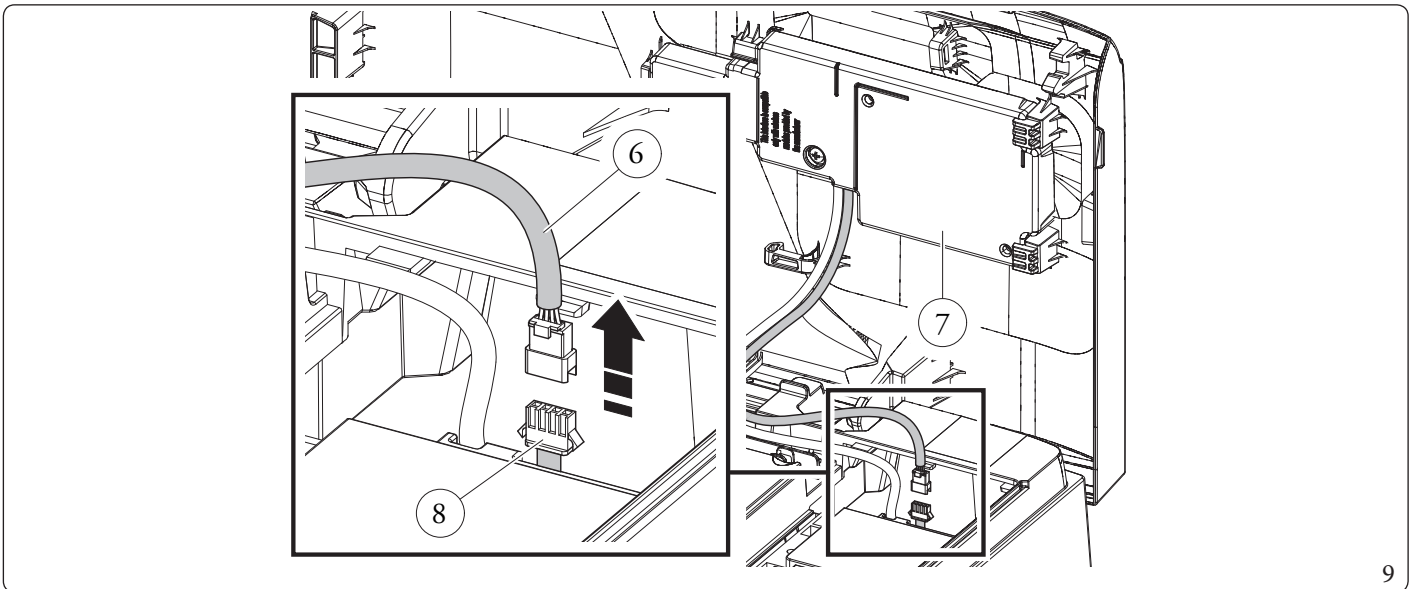

4. Loosen the screw (9, Fig. 10) and, with the help of a screwdriver (10, Fig. 10), remove the display board (11, Fig. 10).

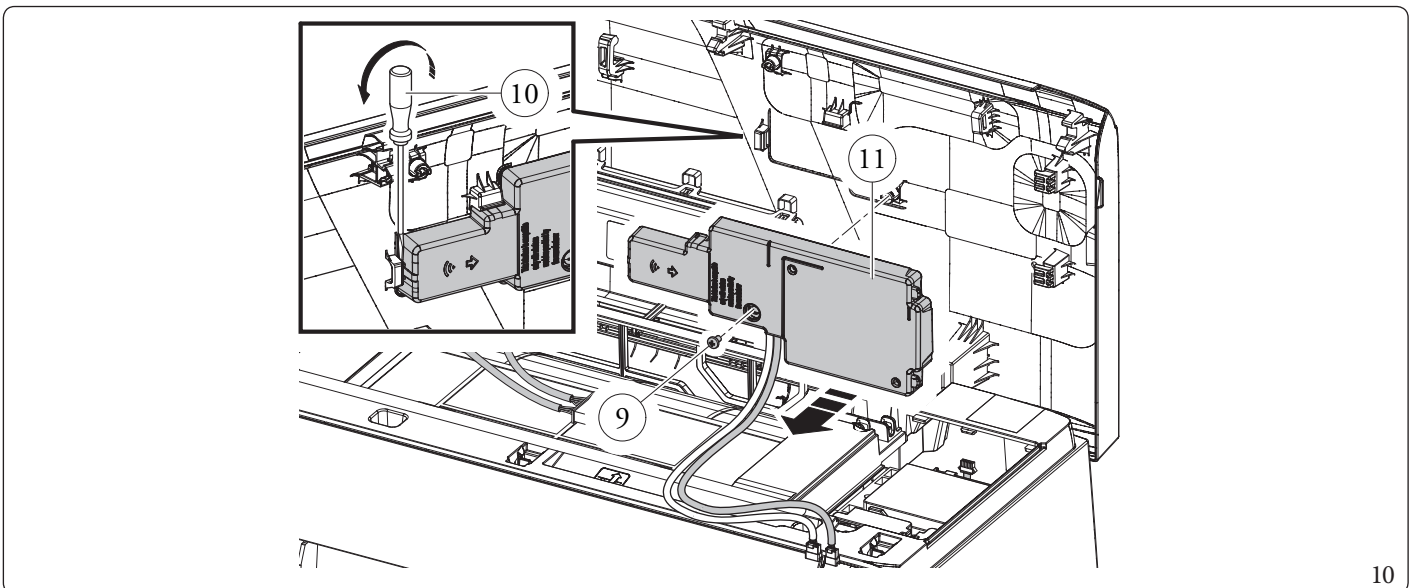

5. Disconnect and remove the display board (12, Fig. 11) the cables (13, Fig. 11) as shown in Figure 11.

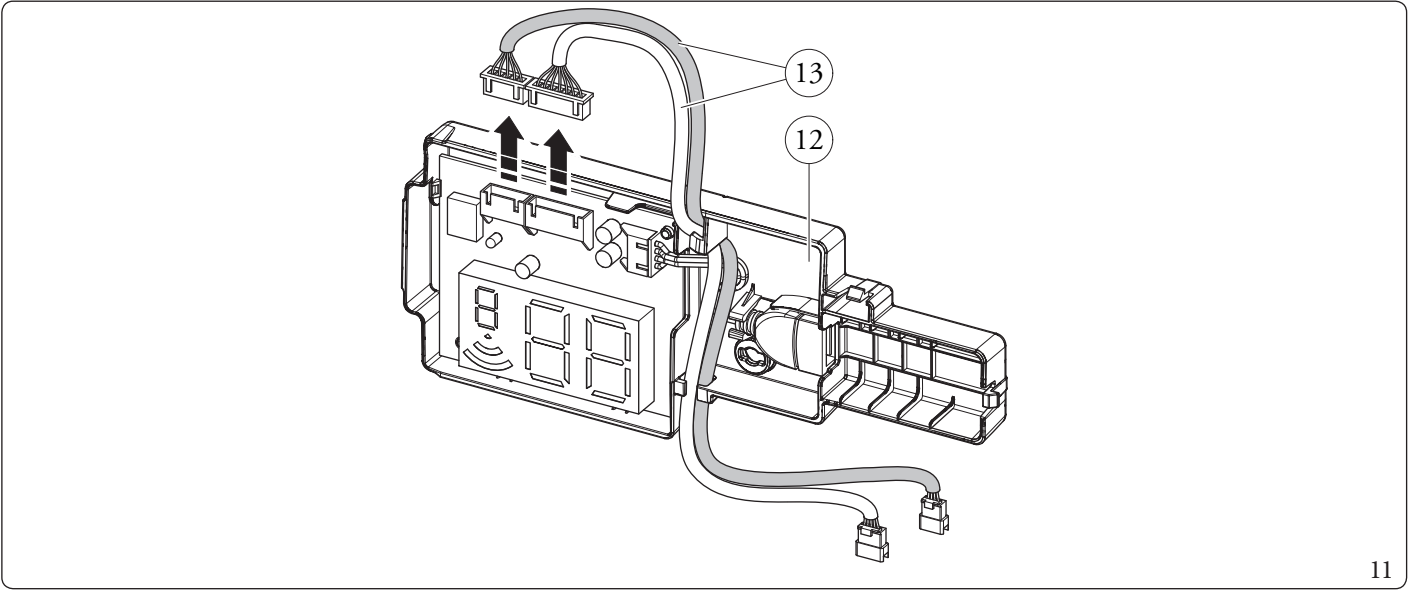

6. Connect the connector (14, Fig. 12) to the display board (15, Fig. 12) and the connector (16, Fig. 12) to the connector (17, Fig. 12) previously disconnected inside the connection compartment.
7. Reposition the cables so that they are not crushed and so that the display card can be refitted without it remaining raised. The cable routing is the same as for the previously disconnected cables (see Fig. 12)

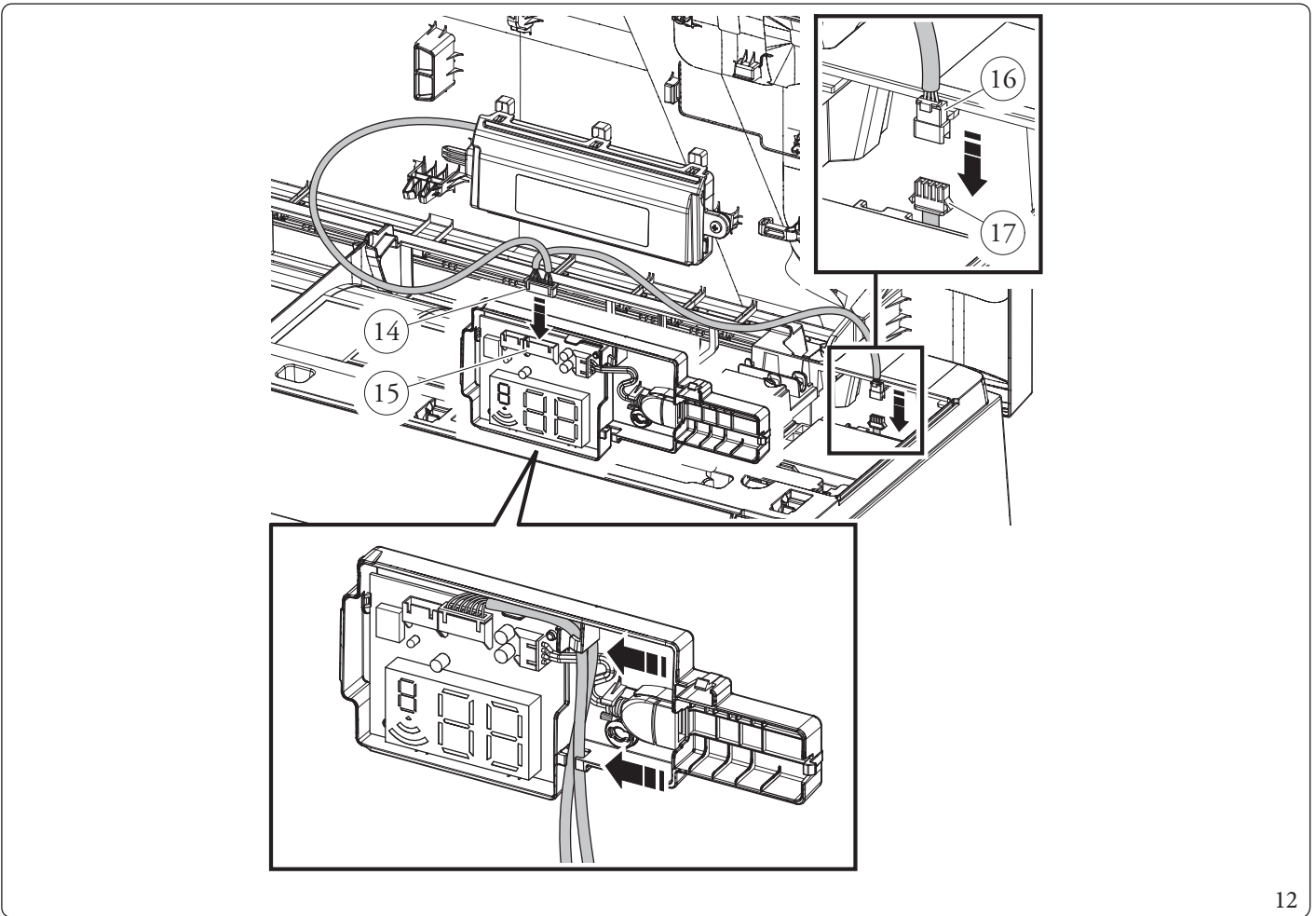

8. Position the cable through the cable glands as shown in Figure 13 and secure the display board (18, Fig. 13) in its original position using the screw (19, Fig. 13) previously loosened.

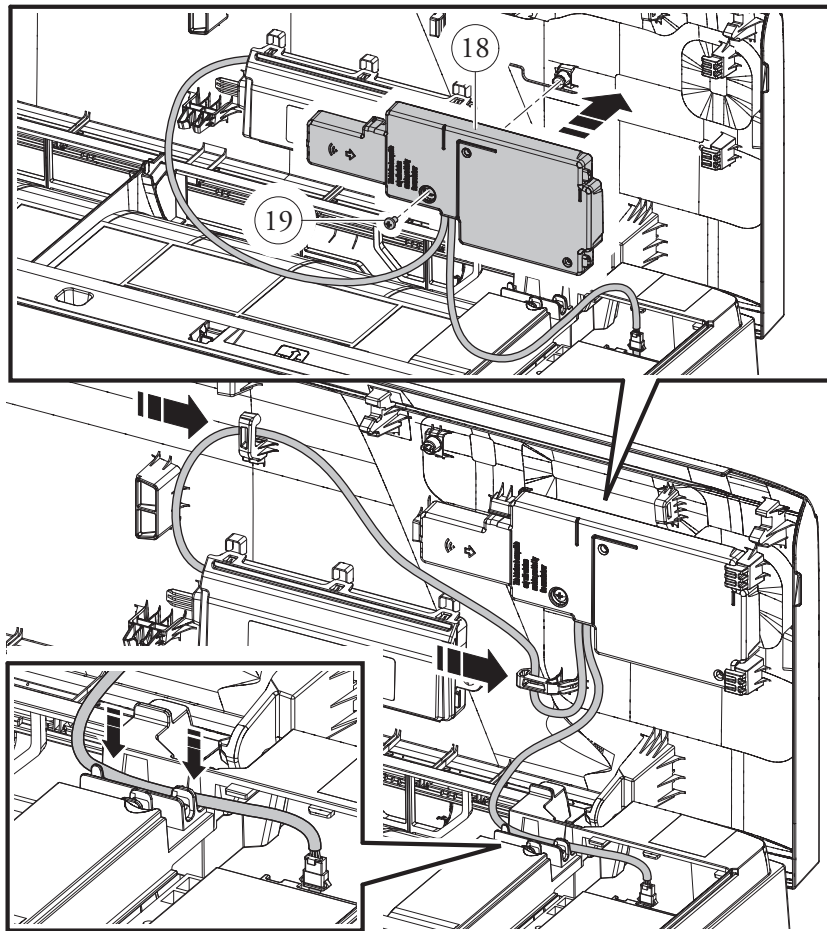

13



For the electrical connection between the "UI Clim" and the "UE Clim", refer to the relevant instruction manual.

9. Pass the interface board power cable (22, Fig. 14) and the Modbus cable (23, Fig. 14), through the connection compartment and connect them to the interface board as shown in Figure 14 and referring to the wiring diagram in Fig. 17.
10. Position the interface board cable (22, Fig. 14) and the Modbus cable (23, Fig. 14) through the cable glands as shown in Fig. 14.

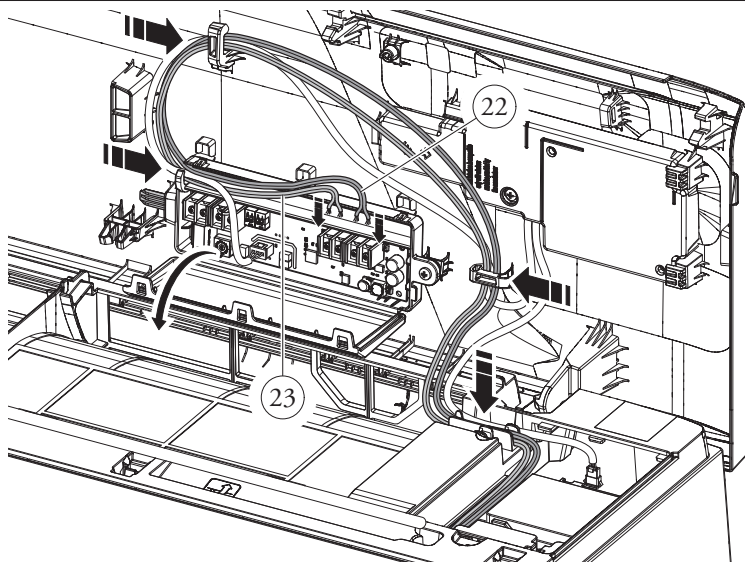

14



11. Close the cover of the interface board (24, Fig. 15) and tighten the screw (25, Fig. 15).

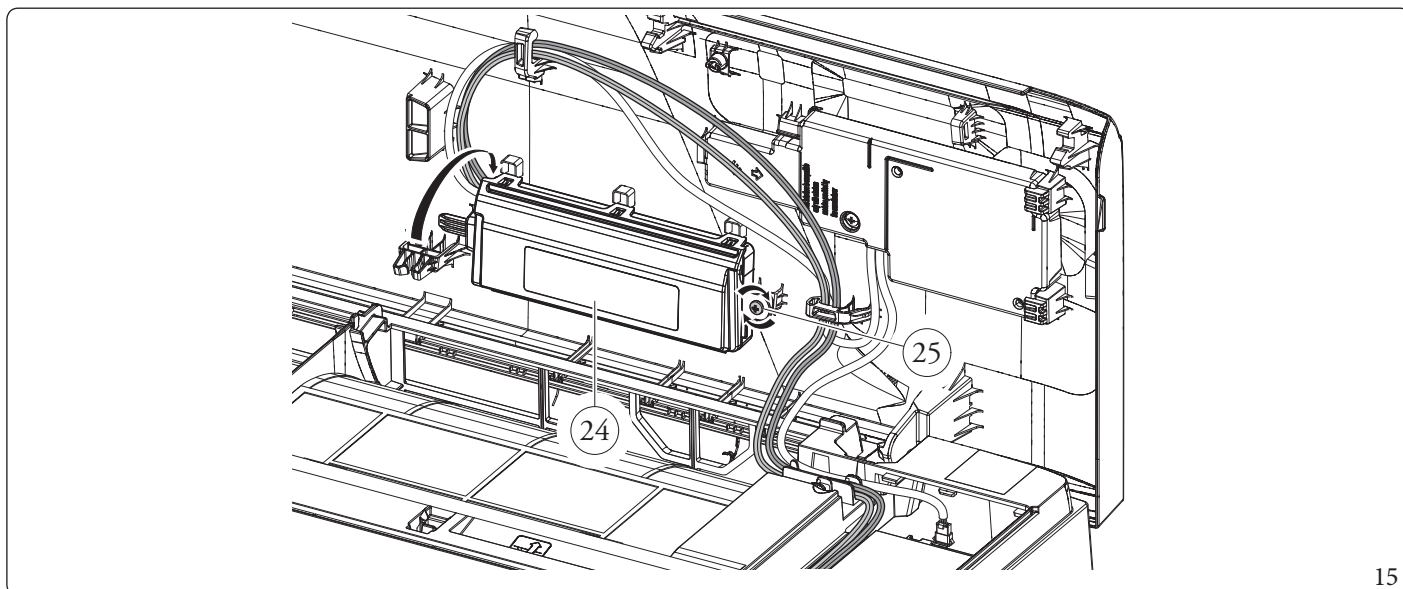

15

12. Close the connection compartment cover (26, Fig. 16) by tightening the screw (27, Fig. 16).

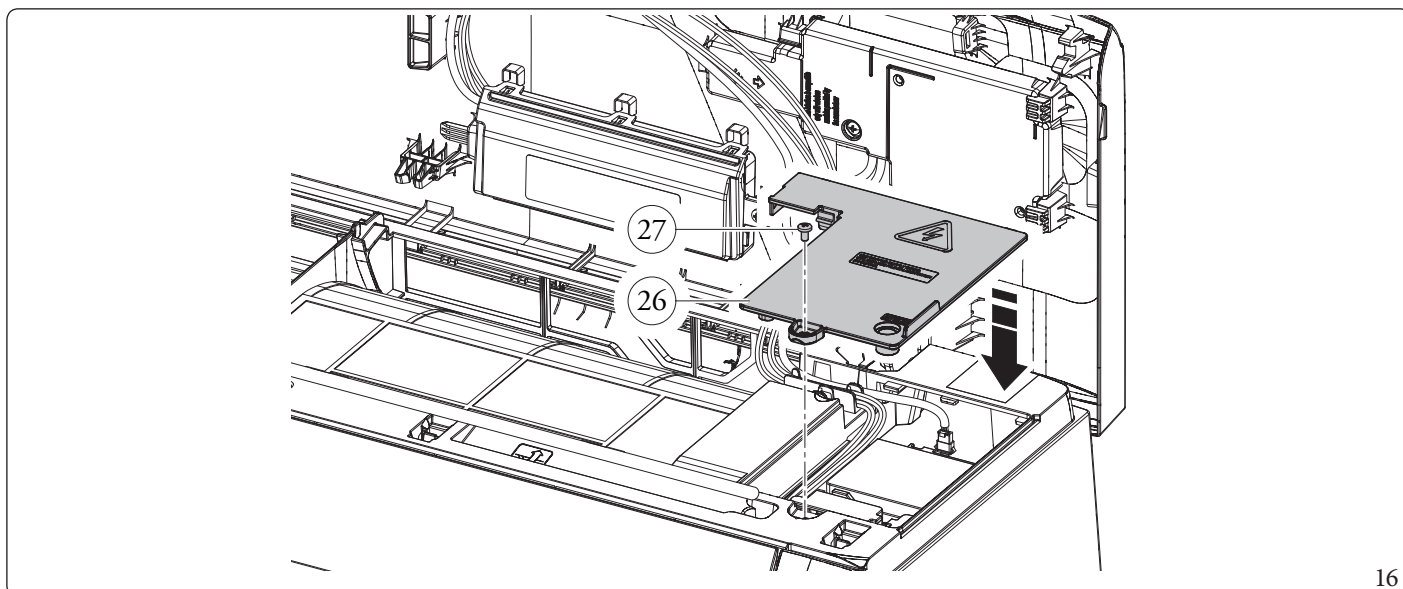

16

From the boiler panel menu, correctly match the "UI Clim" to the zone, choosing the preset address on the interface card, as described at the beginning of this paragraph.

1.9 SYSTEM START-UP (IGNITION)



For system commissioning, refer to the instruction booklets:

- of the boiler (UCIEUREKA);
- of the "UI Clim" air conditioning indoor unit (instruction manual "UI THOR").

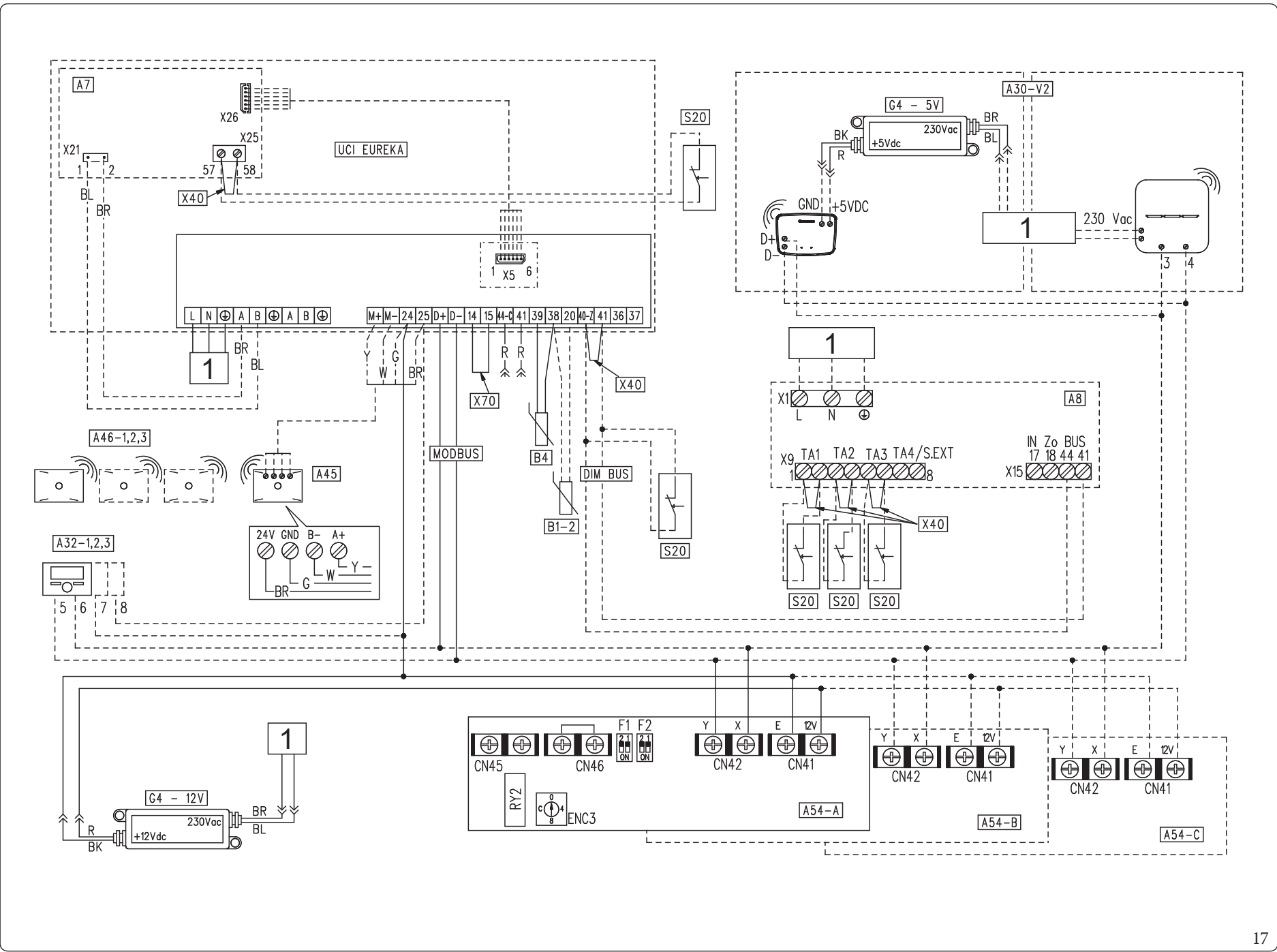

MAINTENANCE TECHNICIAN

USER

INSTALLER

Key (Fig. 17):

A7	-	Relay board (optional)
A8	-	Zone board (optional)
A30-V2	-	Dominus V2 (optional) / Gateway V2 (optional)
A32-1,2,3	-	Remote Zone Panel 1, 2, 3 (optional)
A45	-	Wireless probe concentrator (optional)
A46-1,2,3	-	Zone 1, 2, 3 wireless room probes (optional)
A54-A,B,C	-	"UI Clim" interface board
B1-2	-	System flow probe (optional)
B4	-	External probe
CN46	-	UI remote control enable jumper
ENC3	-	Rotary switch
G4-5V	-	DC power supply device (5V) (optional)
G4-12V	-	DC power supply device (12V)
S20	-	Room thermostat (optional)
UCIEUREKA	-	Condensing boiler
X40	-	Room thermostat jumper (A7, A8 and UCIEUREKA)
X70	-	Safety thermostat (low temperature) link
1	-	230V / 50Hz power supply

Colour code key (Fig. 17):

BK	-	Black
BL	-	Blue
BR	-	Brown
G	-	Green
R	-	Red
W	-	White
Y	-	Yellow

1.11 TYPICAL INSTALLATION EXAMPLES



- The following functional diagrams are displayed by way of example.
- Check the instruction booklets of the boiler ("UCIEUREKA") and the air conditioning units (UI THOR + UE THOR) for the set up of the hydraulic and electric connections and for the cross-section of the cables.
- For component positioning and maximum permissible distances, refer to the instruction manuals for the boiler ("UCIEUREKA") and air conditioner (UI THOR + UE THOR).

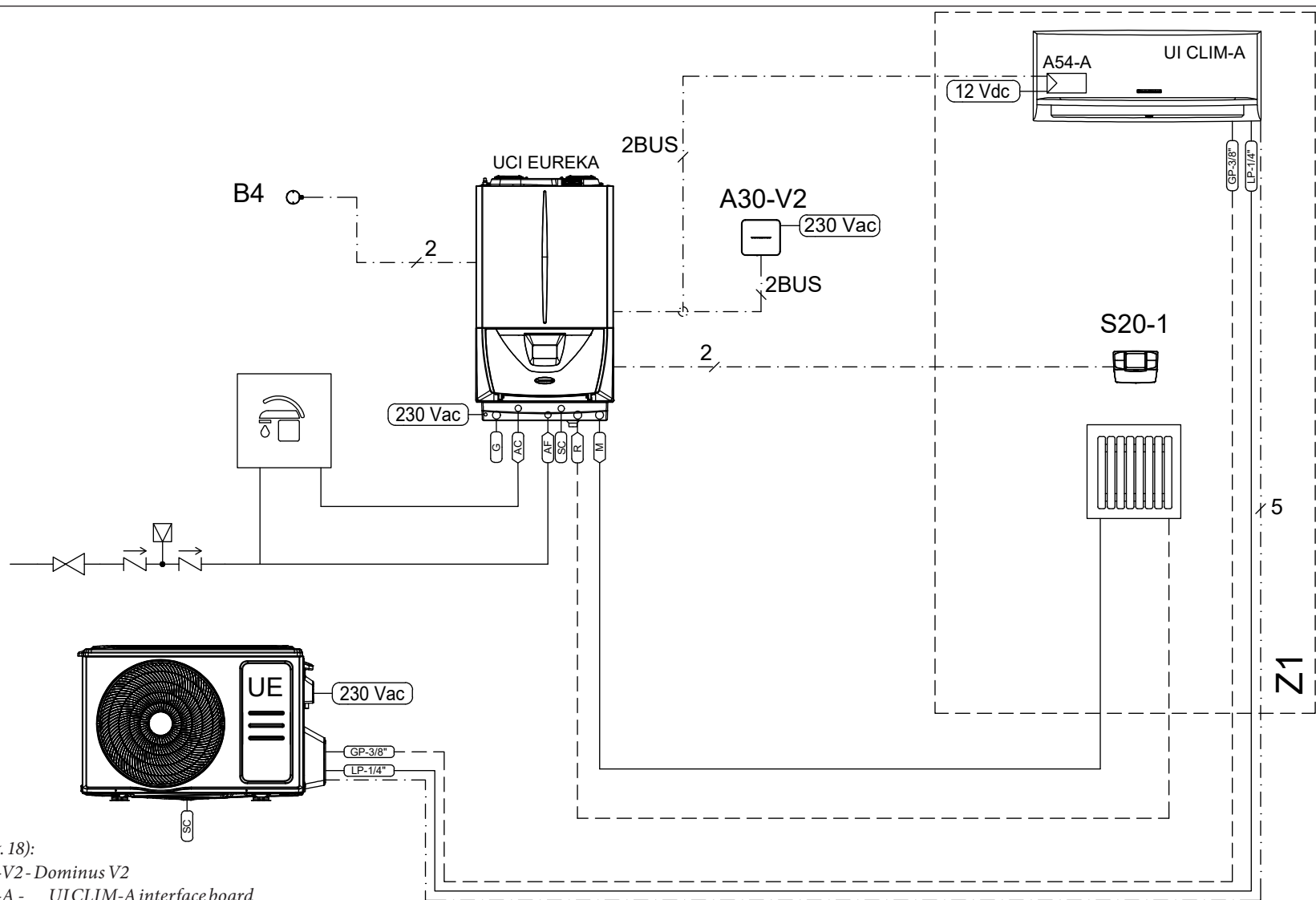

Key (Fig. 18):

- A30-V2 - Dominus V2
- A54-A - UI CLIM-A interface board
- B4 - External probe
- S20-1 - Zone 1 room thermostat
- UE - Air conditioning outdoor unit
- Z1 - Zone 1
- UCI EUREKA - Condensing boiler
- UI CLIM-A - Zone 1 air conditioning indoor unit



- Remember to install the condensate drain circuits.
- This functional diagram is an example.
- Check the instruction booklets for the set up of the hydraulic and electric connections and for the cross-section of the cables.
- Check the instruction booklets for component positioning and maximum permissible distances.
- Use a HO7RN-F type cable for the UI CLIM - UE CLIM electrical connection.
- A magnetic cyclonic filter is supplied as standard with the product, to be installed.



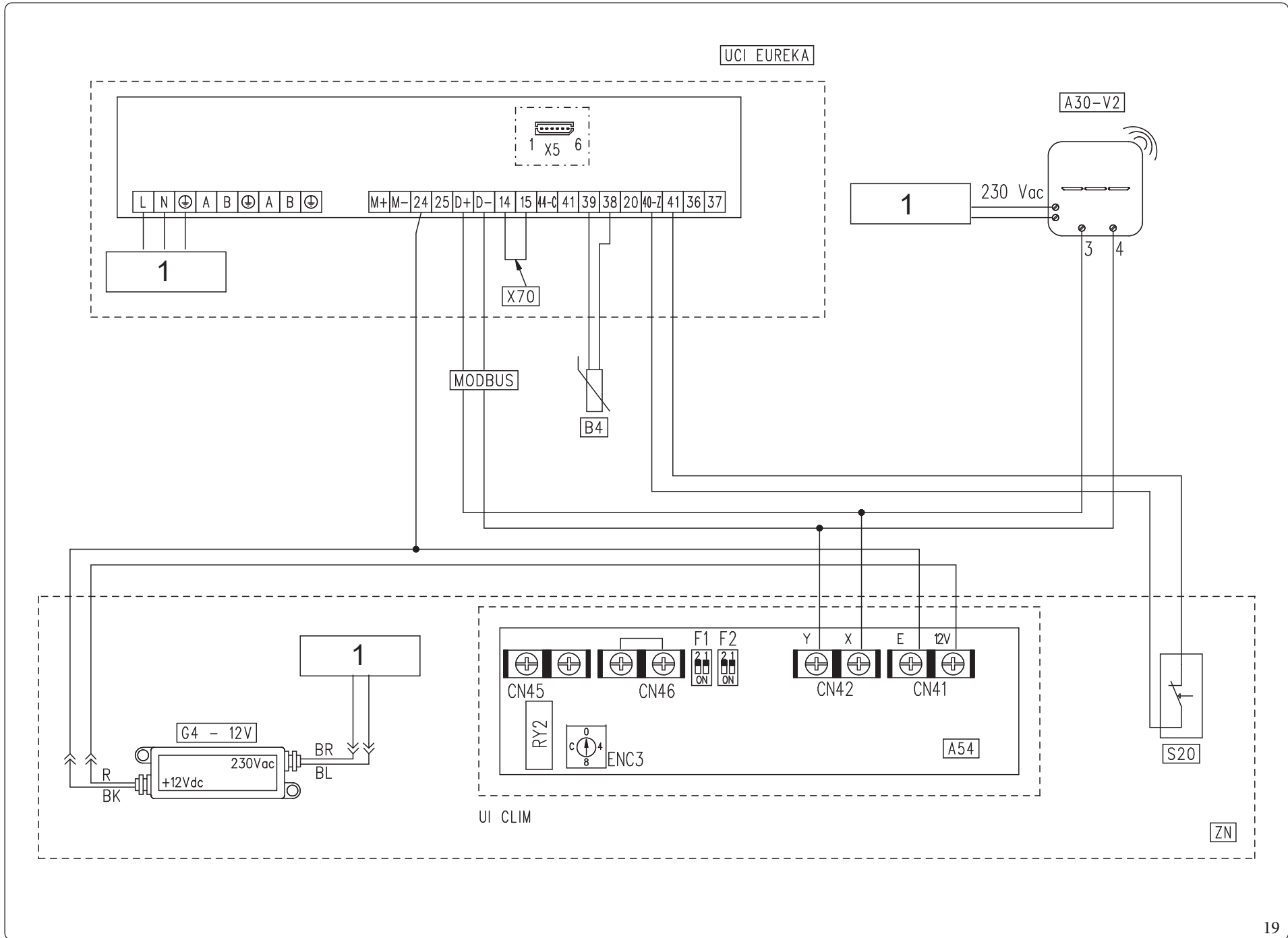

Key (Fig. 19):

- A30-V2 - Dominus V2
- A54 - UICLIM interface board
- B4 - External probe
- CN46 - UI remote control enable jumper
- ENC3 - Rotary switch
- G4-12V - DC power supply device (12V)
- S20 - Zone room thermostat
- UICLIM - Air conditioning indoor unit
- X70 - Safety thermostat (low temperature) link
- ZN - Zone
- 1 - 230V/50Hz power supply

Colour code key (Fig. 19):

- BK - Black
- BL - Blue
- BR - Brown
- G - Green
- GY - Grey
- OR - Orange
- R - Red
- W - White
- Y - Yellow

Configuration parameters	
Parameter path	Value to be set
Menu/Support/Modbus/Dominus	YES
Menu/Support/Hybrid system/System control/Hybrid CH enable	YES
Menu/Support/Hybrid system/IU ACA/ Paired area	1
Menu/Support/Hybrid system/IU ACA/ ACIU Address	A

INSTALLER

USER

MAINTENANCE TECHNICIAN



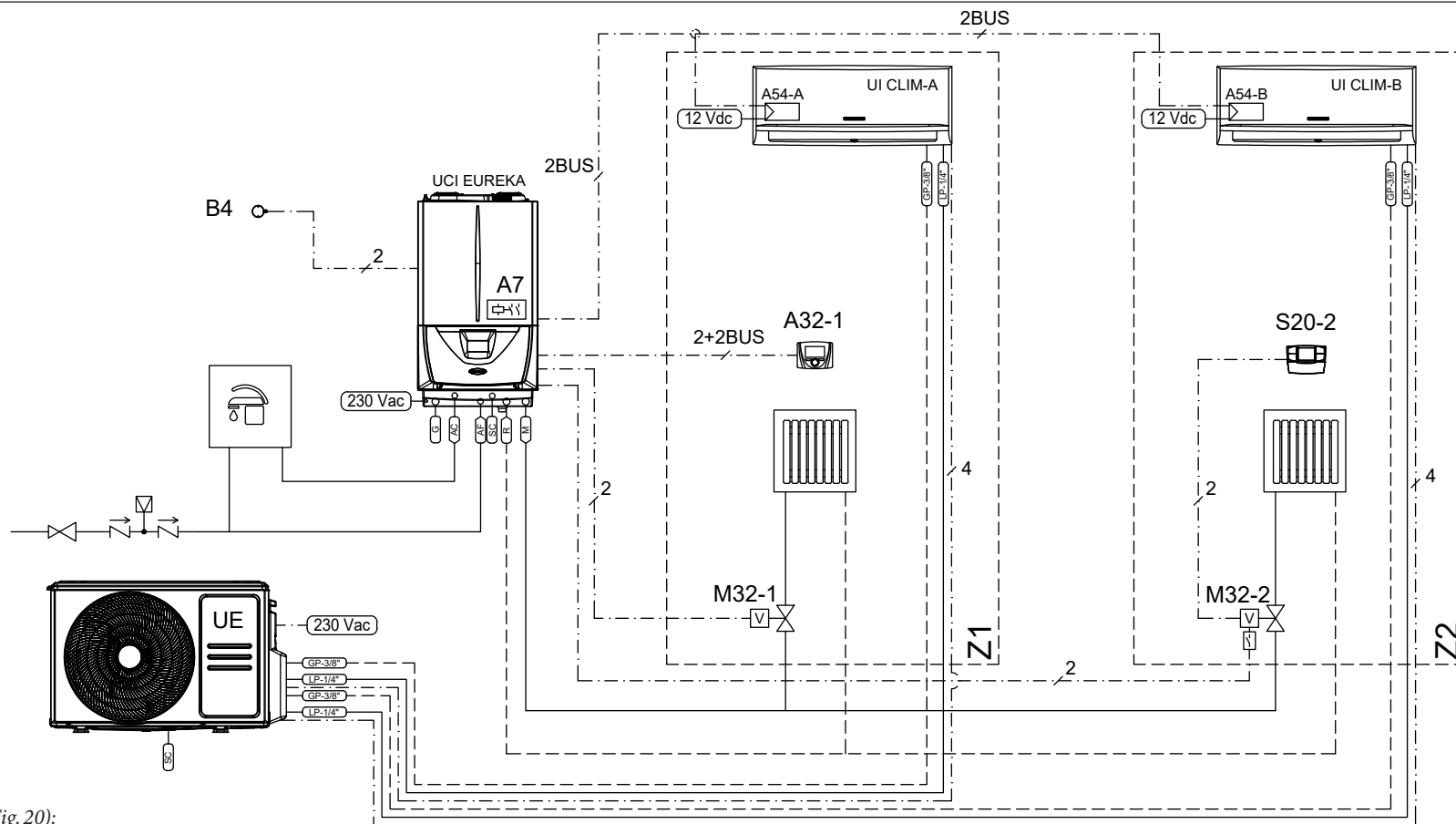

Hydraulic diagram

1.11.2 DUAL + 2 zones installation diagram with zone valves (1 Remote Panel + 1 RT)

Key (Fig. 20):

- A7 - Configurable relay interface kit
- A32-1 - Remote Zone Panel 1
- A54-A - UI CLIM-A interface board
- A54-B - UI CLIM-B interface board
- B4 - External probe
- M32-1 - Zone valve 1
- M32-2 - Zone valve 2
- S20-2 - Zone 2 room thermostat
- UE - Air conditioning outdoor unit
- Z1 - Zone 1
- Z2 - Zone 2
- UCIEUREKA - Condensing boiler
- UI CLIM-A - Zone 1 air conditioning indoor unit
- UI CLIM-B - Zone 2 air conditioning indoor unit



- Remember to install the condensate drain circuits.
- This functional diagram is an example.
- Check the instruction booklets for the set up of the hydraulic and electric connections and for the cross-section of the cables.
- Check the instruction booklets for component positioning and maximum permissible distances.
- Use a HO7RN-F type cable for the UI CLIM - UE CLIM electrical connection.
- A magnetic cyclonic filter is supplied as standard with the product, to be installed.



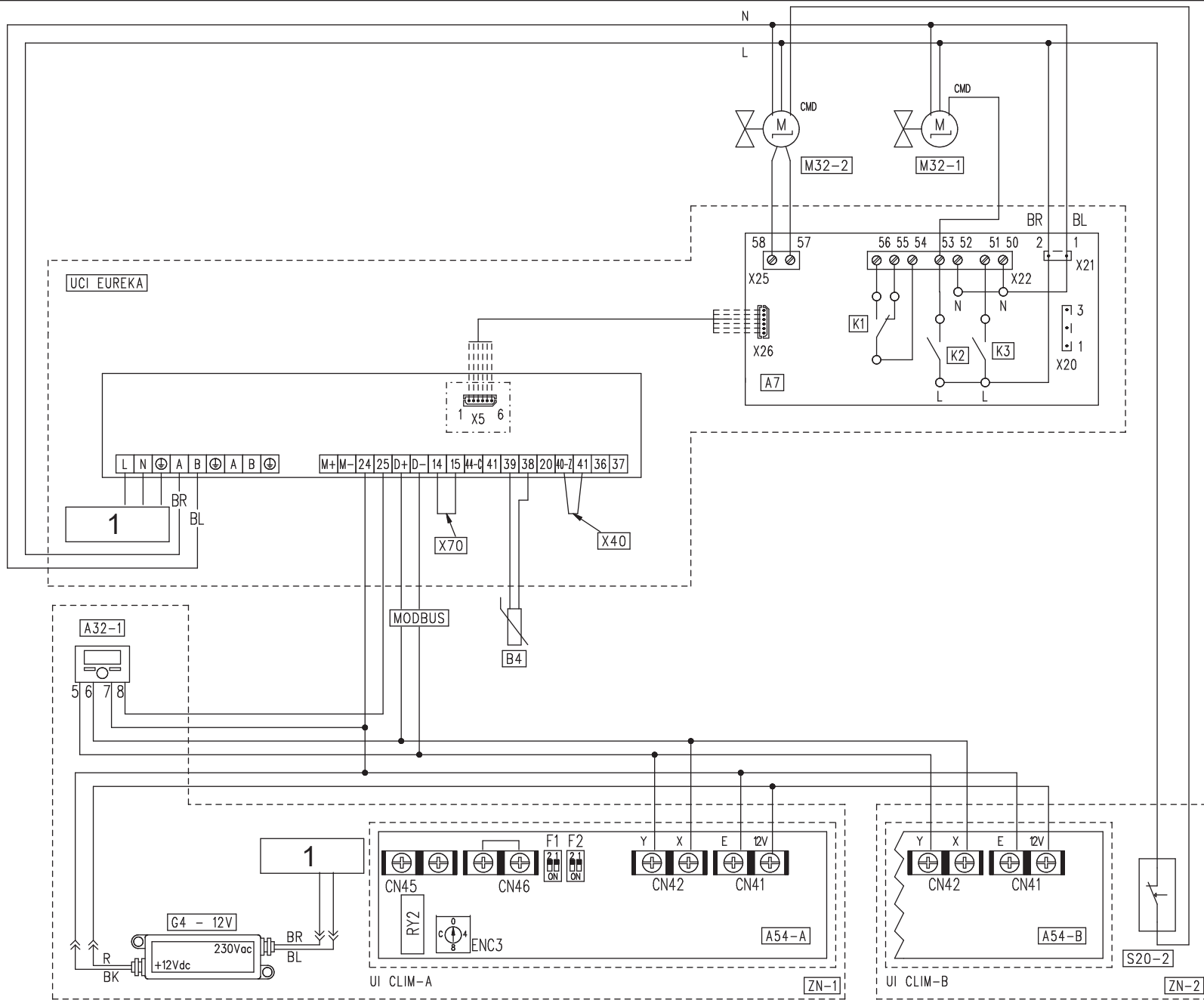

Key (Fig. 21):

- A7 - Relayboard
- A32-1 - Remote Zone Panel 1
- A54-A,B - UI CLIM interface board
- B4 - External probe
- CN46 - UI remote control enable jumper
- ENC3 - Rotary switch
- G4-12V - DC power supply device (12V)
- M32-1,2 - Zone 1.2 valve
- S20-2 - Zone 2 room thermostat
- UI CLIMA,B - Air conditioning indoor unit (A, B)
- X40 - Room thermostat jumper (A7, A8 and UCIEUREKA)
- X70 - Safety thermostat (low temperature) link
- ZN-1,2 - Zone 1, 2
- 1 - 230V / 50Hz power supply

Colour code key (Fig. 21):

- BK - Black
- BL - Blue
- BR - Brown
- G - Green
- GY - Grey
- OR - Orange
- R - Red
- W - White
- Y - Yellow

Configuration parameters	
Parameter path	Value to be set
Menu / Support / Modbus / Panel Z1	YES
Menu / Support / Modbus / Panel Z2	YES
Menu / Support / Hybrid system / System control / Hybrid CH enable	YES
Menu / Support / Hybrid system / IU ACA / Paired area	1
Menu / Support / Hybrid system / IU ACA / ACIU Address	A
Menu / Support / Hybrid system / IU ACC / Paired area	2
Menu / Support / Hybrid system / IU ACC / ACIU Address	B
Menu / Support / Boiler / External relays / Relay 2	Zone 1



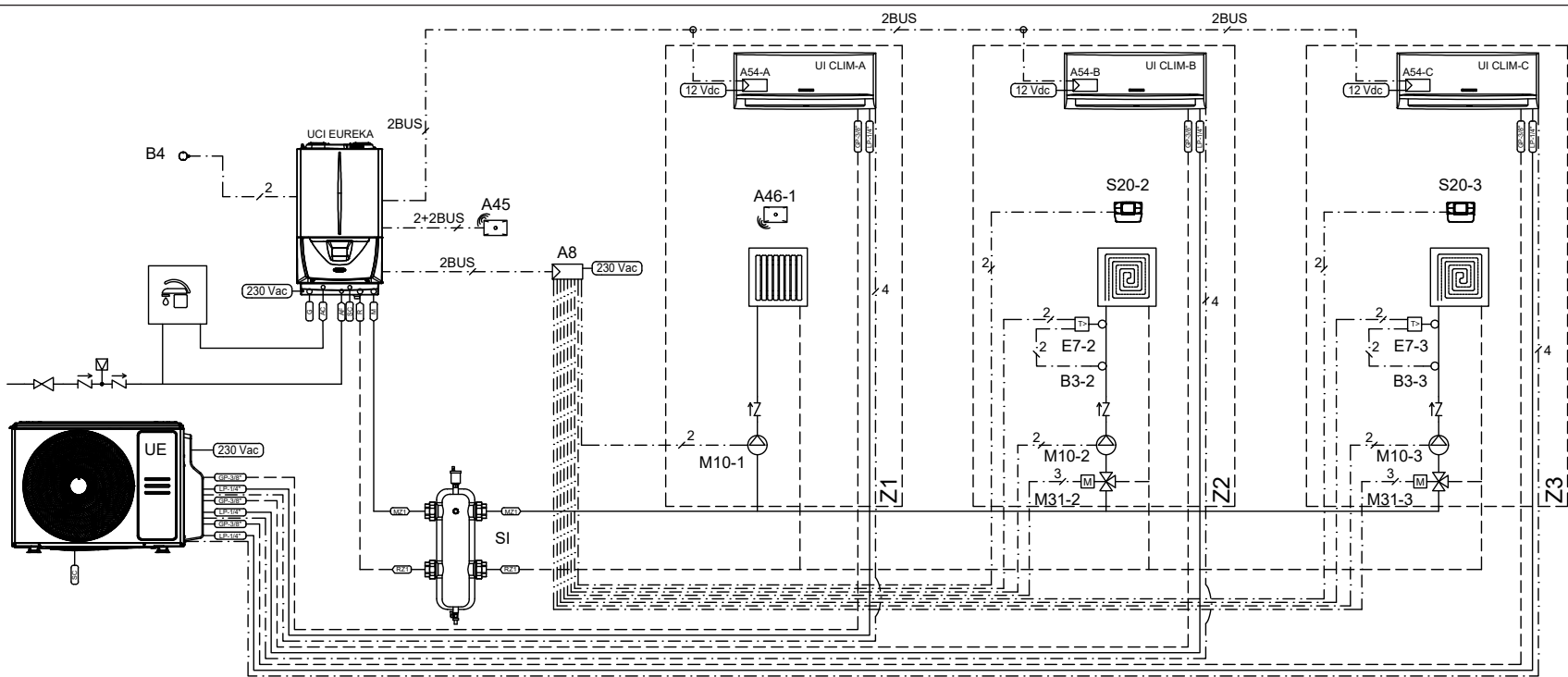

Key (Fig. 22):

- A8 - V2 zone control unit
- A45 - Wireless probe concentrator
- A46-1 - Zone 1 wireless probe
- A54-A - UI CLIM-A interface board
- A54-B - UI CLIM-B interface board
- A54-C - UI CLIM-C interface board
- B3-2 - Zone 2 flow probe
- B3-3 - Zone 3 flow probe
- B4 - External probe

- E7-2 - Zone 2 safety thermostat
- E7-3 - Zone 3 safety thermostat
- M10-1 - Zone 1 booster pump
- M10-2 - Zone 2 booster pump
- M10-3 - Zone 3 booster pump
- M31-2 - Zone 2 mixing valve
- M31-3 - Zone 3 mixing valve
- S20-2 - Zone 2 room thermostat
- S20-3 - Zone 3 room thermostat
- SI - Hydraulic separator

- UE - Air conditioning outdoor unit
- Z1 - Zone 1
- Z2 - Zone 2
- Z3 - Zone 3
- UCI EUREKA - Condensing boiler
- UI CLIM-A - Zone 1 air conditioning indoor unit
- UI CLIM-B - Zone 2 air conditioning indoor unit
- UI CLIM-C - Zone 3 air conditioning indoor unit



- Remember to install the condensate drain circuits.
- This functional diagram is an example.
- Check the instruction booklets for the set up of the hydraulic and electric connections and for the cross-section of the cables.
- Check the instruction booklets for component positioning and maximum permissible distances.
- Use a HO7RN-F type cable for the UI CLIM - UE CLIM electrical connection.
- A magnetic cyclonic filter is supplied as standard with the product, to be installed.



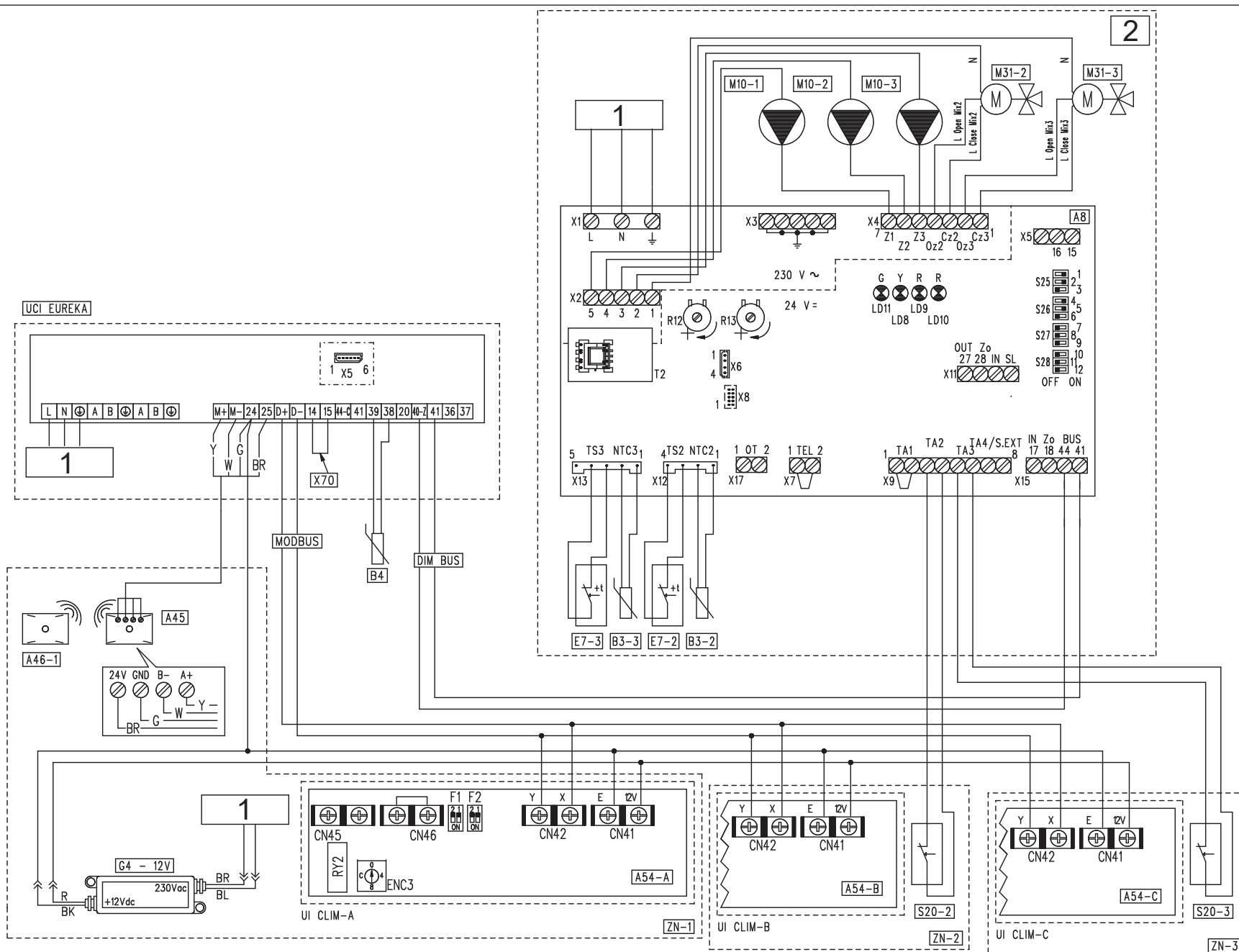

Key (Fig. 23):

- A8 - Zones control unit
- A45 - Wireless probe concentrator
- A46-1 - Zone 1 room wireless probe
- A54-A,B,C - UI CLIM interface board
- B3-2,3 - Zone 2, 3 low temperature flow probe
- B4 - External probe
- CN46 - UI remote control enable jumper
- ENC3 - Rotary switch
- E7-2,3 - Zone 2, 3 safety thermostat (low temperature)
- G4-12V - DC power supply device (12V)
- M10-1,2,3 - Zone 1, 2, 3 concentrator
- M31-2,3 - Zone 2,3 mixing valve
- R12 - Zone 2 low temperature supply adjustment trimmer
- R13 - Zone 3 low temperature supply adjustment trimmer
- S20-2,3 - Zone 2, 3 room thermostat
- S25...S28 - P.C.B. setting selector
- T2 - Zones control unit low voltage power supply
- UI CLIMA,B,C - Air conditioning indoor unit (A, B, C)
- X70 - Safety thermostat (low temperature) link
- Z1 - Antijamming filter
- ZN-1,2,3 - Zone 1, 2, 3
- 1 - 230V/50Hz power supply
- 2 - Zones control unit

Colour code key (Fig. 23):

- BK - Black
- BL - Blue
- BR - Brown
- G - Green
- GY - Grey
- OR - Orange
- R - Red
- W - White
- Y - Yellow

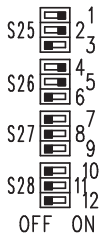
Configuration parameters	
Parameter path	Value to be set
Menu / Support / Hybrid system / System control / Hybrid CH enable	YES
Menu / Support / Hybrid system / IU ACA / Paired area	1
Menu / Support / Hybrid system / IU ACA / ACIU Address	A
Menu / Support / Hybrid system / IU ACB / Paired area	2
Menu / Support / Hybrid system / IU ACB / ACIU Address	B
Menu / Support / Hybrid system / IU ACC / Paired area	3
Menu / Support / Hybrid system / IU ACC / ACIU Address	C
Zones / Zone 1 / Configuration / Room probe / Type	RF
Zones / Zone 1 / Configuration / Room probe / Address M3	1
V2 zone control unit board	

INSTALLER

USER

MAINTENANCE TECHNICIAN



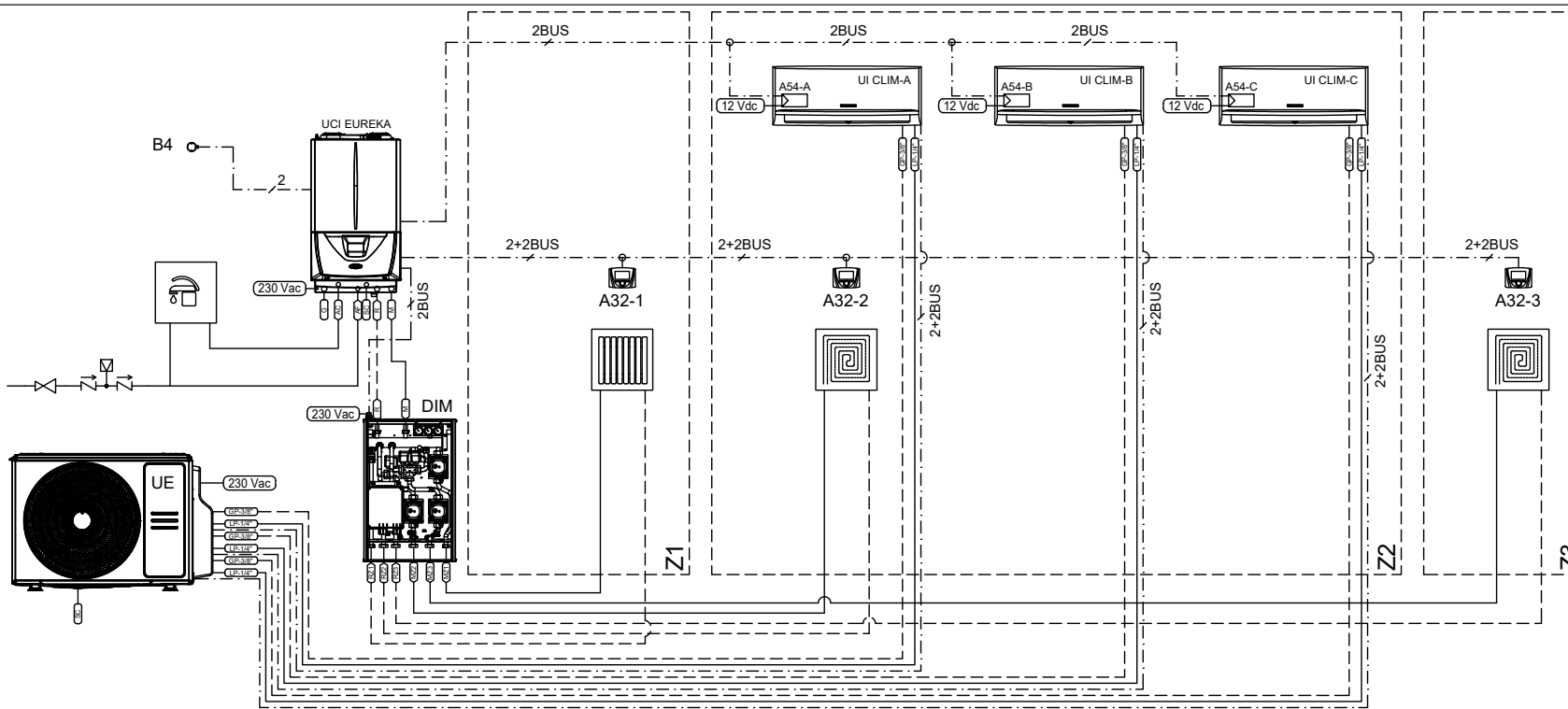

Key (Fig. 24):

- A32-1 - Zone 1 remote panel
- A32-2 - Zone 2 remote panel
- A32-3 - Zone 3 remote panel
- A54-A - UI CLIM-A interface board
- A54-B - UI CLIM-B interface board
- A54-C - UI CLIM-C interface board
- B4 - External probe

- DIM - Multi-system water circuit breaker
- UE - Air conditioning outdoor unit
- Z1 - Zone 1
- Z2 - Zone 2
- Z3 - Zone 3
- UCI EUREKA - Condensing boiler
- UI CLIM-A,B,C - Zone 2 air conditioning indoor unit



- Remember to install the condensate drain circuits.
- This functional diagram is an example.
- Check the instruction booklets for the set up of the hydraulic and electric connections and for the cross-section of the cables.
- Check the instruction booklets for component positioning and maximum permissible distances.
- Use a HO7RN-F type cable for the UI CLIM - UE CLIM electrical connection.
- A magnetic cyclonic filter is supplied as standard with the product, to be installed.



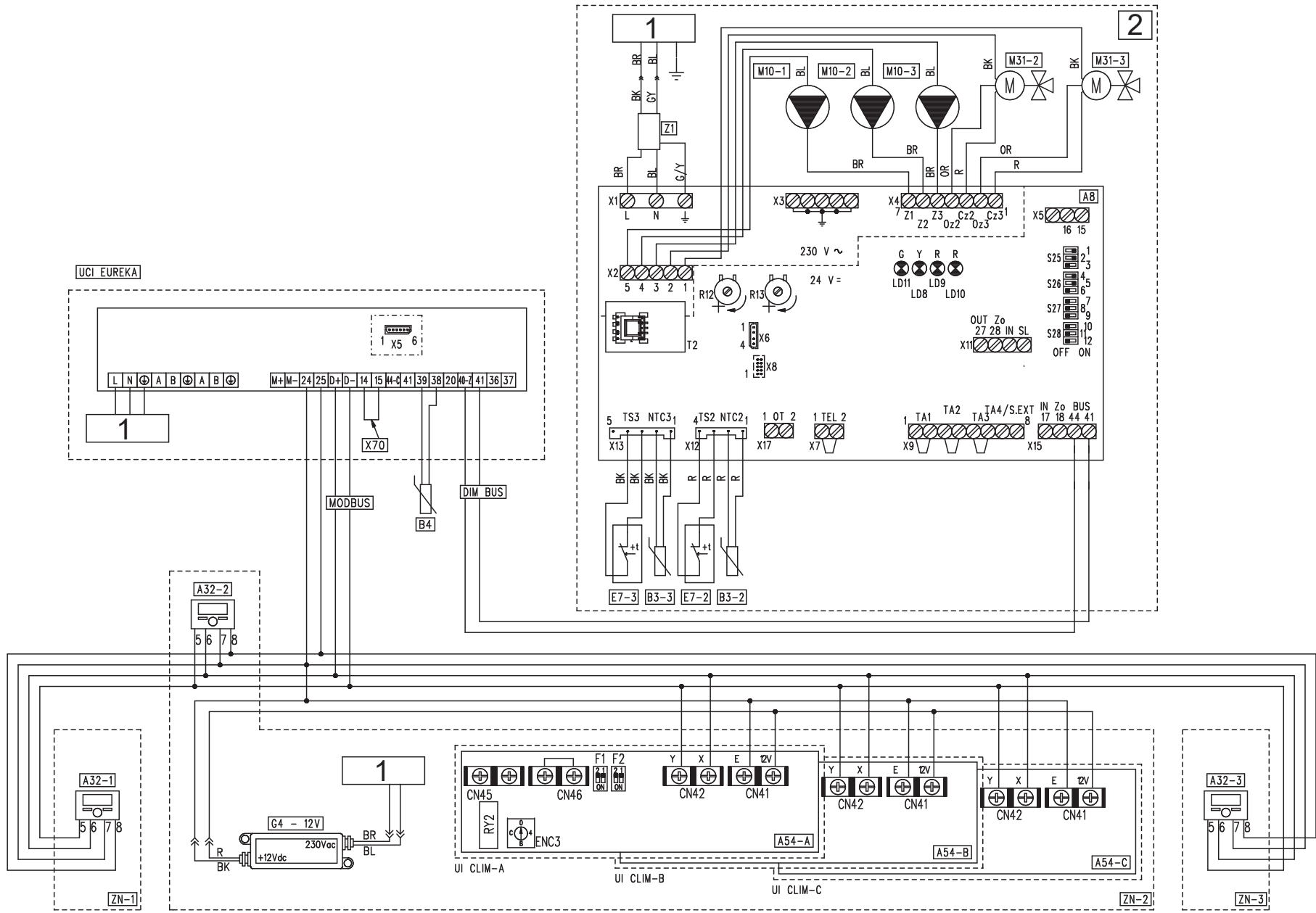

Key (Fig. 25):

- A8 - Zone board (optional)
- A32-1,2,3 - Remote Zone Panel 1, 2, 3 (optional)
- A54-A,B,C - UI CLIM interface board
- B3-2,3 - Zone 2, 3 low temperature flow probe
- B4 - External probe
- CN46 - UI remote control enable jumper
- ENC3 - Rotary switch
- E7-2,3 - Zone 2, 3 safety thermostat (low temperature)
- G4-5V - DC power supply device (5V) (optional)
- G4-12V - DC power supply device (12V)
- M10-1,2,3 - Zone 1, 2, 3 concentrator
- M31-2,3 - Zone 2.3 mixing valve
- R12 - Zone 2 low temperature supply adjustment trimmer
- R13 - Zone 3 low temperature supply adjustment trimmer
- S25...S28 - P.C.B. settings selector
- T2 - Zones control unit low voltage power supply
- UI CLIMA,B,C - Air conditioning indoor unit (A, B, C)
- X70 - Safety thermostat (low temperature) link
- Z1 - Antijamming filter
- ZN-1,2,3 - Zone 1, 2, 3
- 1 - 230V / 50Hz power supply
- 2 - Zones control unit

Colour code key (Fig. 25):

- BK - Black
- BL - Blue
- BR - Brown
- G - Green
- GY - Grey
- OR - Orange
- R - Red
- W - White
- Y - Yellow

Configuration parameters

Parameter path	Value to be set
Menu / Support / Modbus / Panel Z1	YES
Menu / Support / Modbus / Panel Z2	YES
Menu / Support / Modbus / Panel Z3	YES
Menu / Support / Hybrid system / System control / Hybrid CH enable	YES
Menu / Support / Hybrid system / IU ACA / Paired area	2
Menu / Support / Hybrid system / IU ACA / ACIU Address	A
Menu / Support / Hybrid system / IU ACB / Paired area	2
Menu / Support / Hybrid system / IU ACB / ACIU Address	B
Menu / Support / Hybrid system / IU ACC / Paired area	2
Menu / Support / Hybrid system / IU ACC / ACIU Address	C
DIMA/2BT	1 Dir - 2 Misc



2 USER INSTRUCTIONS



For safety purposes, the user must carefully read all that is in this manual in the section under their competence and should any doubts arise, before taking any initiative, must ask the installer or their maintenance technician (such as for example Immergas authorised service centre).



The device can be used by children at least 8 years old as well as by persons with reduced physical, sensory or mental capabilities, or lack of experience or required knowledge, provided that they are under surveillance, or after they have been instructed relating to the safe use and have understood the potential dangers.

Children must not play with the appliance.

Cleaning and maintenance destined to be performed by the user can not be carried out by unsupervised children.



Never clean the appliance or connected parts with easily flammable substances.



Do not open or tamper with the appliance.



Only use the user interface devices listed in this section of the booklet.



Do not climb on the appliance, do not use the appliance as a support base.



In the event of malfunctions, faults or incorrect operation, turn the appliance off and contact an authorised company (e.g. the Authorised Technical Assistance Centre, which has specifically trained staff and original spare parts).
Do not attempt to modify or repair the appliance alone.



**Water at a temperature of more than 50°C can cause serious burns.
Always check the water temperature before any use.**



The temperatures indicated by the display have a tolerance of +/- 3°C due to environmental conditions that cannot be blamed on the appliance.



If you smell burning or see smoke coming out of the appliance, switch it off, disconnect power and call an authorised company (e.g. Authorised Technical Assistance Centre).



**At the end of its service life, the appliance must not be disposed of like normal household waste nor abandoned in the environment, but must be removed by a professionally authorised company as required by current legislation.
Contact the manufacturer for disposal instructions.**





The use of components involving use of electrical power requires some fundamental rules to be observed such as:

- do not touch the appliance with wet or moist parts of the body;
- do not pull the electric cables;
- the appliance power cable must not be replaced by the user;
- in the event of damage to the cable, switch off the appliance and contact exclusively personnel professionally qualified pursuant to standards in force for its replacement;
- if the appliance is not to be used for a certain period, disconnect the main appliance external switch.



2.1 USE OF THE REMOTE CONTROL AND THE “CLIMA SMART” APP



The settings below, referring to "Zone 1", can be applied in the same way or differentiated to "Zone 2" and/or "Zone 3".

The following accessories are provided for each “UI Clim” in the system:

- an RF remote control
- a Wi-Fi dongle that allows the use of the “Clima Smart” app.

These two devices can be used for any hybrid system configuration.

The use of both accessories is guaranteed:

a) in cooling mode

If you prefer to use the two accessories and the application, as an alternative to management via the hybrid system and relative thermostatic regulation, we suggest the following parameter setting "Hybrid Cool. Syst. Mode":

ZONES/Zone 1/Settings/Hybrid system/Cooling	
Menu item	Parameter to be set
Hybrid Cool. Syst. Mode	Remote IU

In this way, the system will be controlled exclusively via the RF remote control and/or ClimaSmart app for this specific mode.

b) in heating mode

If you want to take full advantage of the features of the installed hybrid system, it is not recommended to use the RF Remote Control and the app, as the implemented electronics already manage the entire heating and cooling system.

Please note that both the app and the remote control only allow control of the “UI Clim” and not the complete hybrid system.

Manual changes made via the app/remote control may not remain permanently active. In fact, depending on the configuration of the hybrid system, there may be conditions under which the settings made with the remote control or the app are only temporary. In particular, in the case of time slot configuration, the changes would only be active until the next time slot change.

Other events that cause manual settings made via the app or remote control to be lost include, for example, the reactivation of the system following a power failure or a change in operating mode and any changes to the calendars.

For detailed information on how to use the application and remote control, refer to the relevant instruction sheets.



Both with the remote control and with the application, the use of the “AUTO” mode that can be set on the “UI Clim” is PROHIBITED; this could lead to conflicts with the management of the system by the EUREKA system.

2.2 SETTING THE REQUEST HYSTERESIS



The settings below, referring to "Zone 1", can be applied in the same way or differentiated to "Zone 2" and/or "Zone 3".

If the remote zone panel or wireless room probe is enabled, for each of the zones where one of these devices is present, it is possible to set the activation and deactivation temperature for heating and cooling requests by modifying the following parameters:

ZONES/Zone 1/Configuration/Regulation		
Menu item	Description	Range
Hysteresis CH OFF	Switches off with "RoomT" \geq (room set + "Hysteresis CH OFF")	0.1°C - 5.0°C
Hysteresis CH ON	Switches on with "RoomT" \leq (room set - "Hysteresis CH ON")	0.1°C - 5.0°C
Hysteresis Cool OFF	Switches off with "RoomT" \leq (room set - "Hysteresis Cool OFF")	0.1°C - 5.0°C
Hysteresis Cool. ON	Switches on with "RoomT" \geq (room set + "Hysteresis Cool. ON")	0.1°C - 5.0°C

These parameters can be modified from the factory settings to set the exact room temperature for activating and deactivating the request to the generators. The four separate parameters allow you to set activation and deactivation temperatures for heating and cooling mode.



For more information, refer to the boiler instruction booklet (UCI EUREKA).



2.3 SETTING THE "HYBRID SYSTEM" MENU



The settings below, referring to "Zone 1", can be applied in the same way or differentiated to "Zone 2" and/or "Zone 3".

The user can modify the configuration of the EUREKA system for both heating and cooling; in fact, it will be possible to modify some system settings to find the ideal configuration for your installation.

Using the menu below, you can set the generators to be used and, if both are operating, which one to start first. It is also possible to modify the fan speed to be used by the "UI Clim".

Different settings are provided for the heating and cooling phases.

ZONES/Zone 1/Settings/Hybrid system	
Menu item	Description
C.H.	Configure the central heating function of the EUREKA system
Cooling	Configure the cooling function of the EUREKA system

2.3.1 C.H.

Using the menu below, it is possible to set up a Immergas-preconfigured operating setup that modifies the configuration variables available to the user.

ZONES/Zone 1/Settings/Hybrid system/C.H.	
Menu item	Range
Hybrid CH Syst. Mode	Personal./Only Boil./Only IU/Auto 1/Auto 2/Auto 3/Auto 4/Auto 5/Auto 6

The variables linked to these preconfigurations are shown in the following menu

ZONES/Zone 1/Settings/Hybrid system/C.H.	
Menu item	Variables
Setting Advanced	Activation time
	Set Ventil. CH ACIU
	Generator priority

2.3.1.1 Possible settings of parameter "Hybrid CH Syst. Mode"

"Only Boil."

If the user wishes to remove control of the "UI Clim" from the EUREKA system, it is possible to set the value "Only Boil." on the menu item "Hybrid CH Syst. Mode"; any changes to the "UI Clim" via remote control and/or application will not be overwritten by the system and will remain permanently active until further action is taken by the user.

The management of the request by the EUREKA system is inhibited and the boiler manages the requests as if there were no air conditioning unit present.

This configuration should be selected if the EUREKA system management is unable to guarantee the comfort required by the user.

With this selection, the EUREKA system supervision of the "UI Clim" in the corresponding zone is removed.

"Only IU"

By selecting the value "Only IU" from the menu item "Hybrid CH Syst. Mode", heating requests are only satisfied by the split units using the settings made on the EUREKA system.

Control of the "UI Clim" remains with the EUREKA system, so any changes made with the remote control and/or application will follow the logic set by the system.



"Auto 1"



Recommended settings for radiator systems with "UI Clim" near the controller (room thermostat, Remote Zone Panel or Wireless temperature probe)

During the activation phase, only the "UI Clim" heats the air in the zone and all related rooms; after "Activation time" (15 min) has elapsed at the start of the next phase, the "UI Clim" switches off and only the boiler switches on to heat the emitters (radiators) in the rooms in the zone.

This reduced activation time and the exclusive operation of the boiler in the next phase ensure that all rooms in the area are heated when the hot air flow from the "UI Clim" only partially affects those rooms.

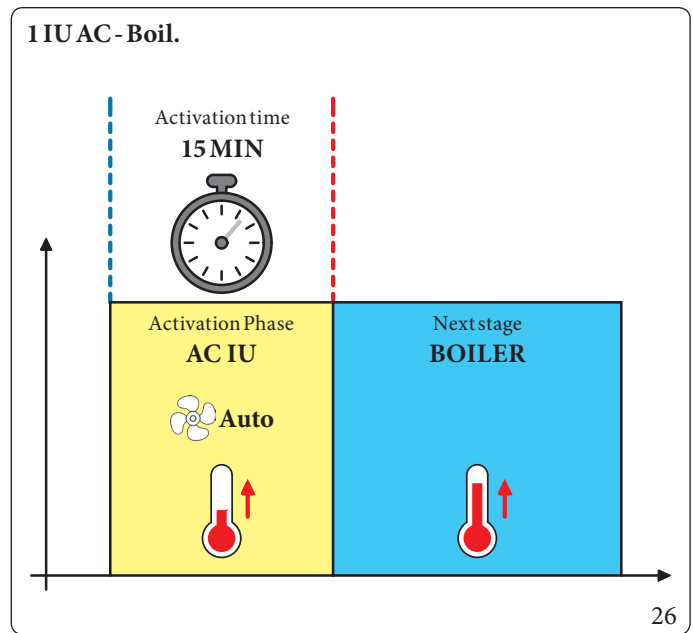

For example, this setting is recommended on the first attempt in installations where the "UI Clim" is positioned very close to the controller, but the room(s) to be heated is/are very large or only partially affected by the air flow from the "UI Clim". In this type of installation, the minimum relative distance between "UI Clim" and the controller may not guarantee uniform heating of the rooms in the zone.

"Auto 2"



Recommended settings for radiator systems with very large rooms.

During the activation phase, only the "UI Clim" heats the air in the rooms in the area; after "Activation time" (15 min) has elapsed at the start of the next phase, the boiler also switches on and contributes to heating through the emitters (radiators) present in the rooms in the area.

This reduced activation time and the simultaneous operation of the two generators in the next phase favour the heating of all the rooms in the area, when the flow of hot air from the "UI Clim" alone is not able to reach all these rooms.

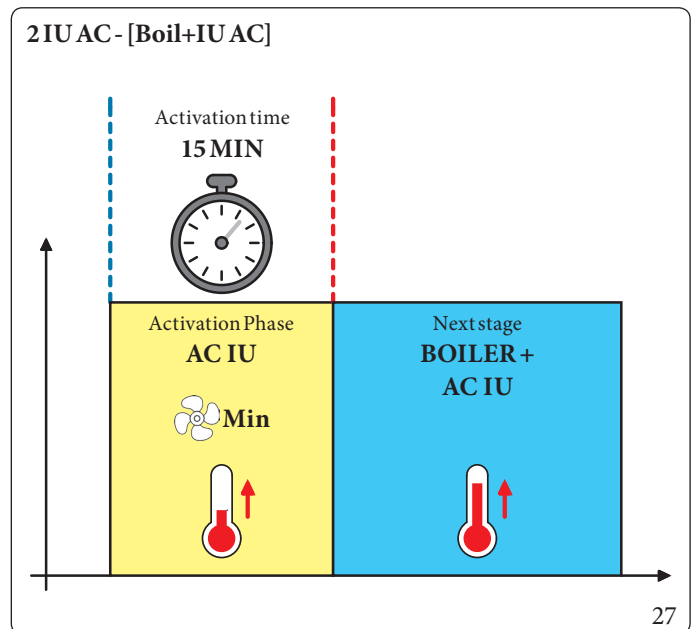

For example, this setting is recommended in installations where "UI Clim" is installed in very large rooms to be heated or rooms that are only partially covered by the air flow from "UI Clim". The initial activation of the "UI Clim" provides additional power in the room where it is installed, and the subsequent simultaneous use of the two generators ensures more uniform heating in all rooms in the area.



"Auto 3"



Recommended settings for radiator systems with very large rooms and with "UI Clim" located far from the controller.

During the activation phase, only the boiler provides heating through the emitters (radiators) located in the rooms in the area; after "Activation time" (60 min.) at the start of the next phase, "UI Clim" also turns on and contributes to heating the rooms in the area.

5 Boil - [Boil+IU AC]

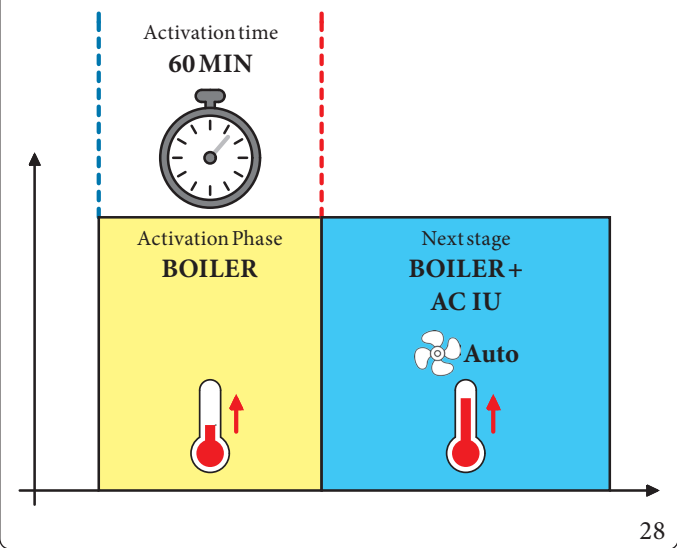

For example, this setting is recommended in installations where "UI Clim" is installed in very large rooms to be heated or rooms that are only partially covered by the air flow from "UI Clim". The subsequent activation of "UI Clim" provides the room where it is installed with additional heating power through the emitters alone.

This means that there is no need to increase the operating temperature of the "UCI EUREKA" boiler on the hydraulic system side to ensure uniform heating of the room where the "UI Clim" is installed.

"Auto 4"



Recommended settings for radiant panel systems with "UI Clim" located away from the controller.

During the activation phase, the simultaneous operation of "UI Clim" and the boiler ensures that all rooms in the area are heated; after "Activation time" (30 min) at the start of the next phase, "UI Clim" switches off and only the boiler remains on for heating via the emitters (radiant panels) in the rooms in the area.

In "Auto 4", as with all suggested trial settings for radiant panel systems, the fan speed of "UI Clim" is set to minimum.

3 [Boil+IU AC] - Boil

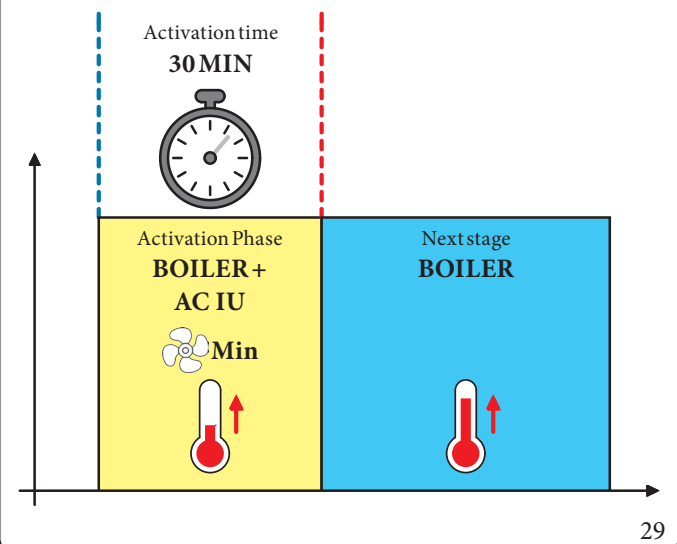

For example, this trial setting is recommended in installations where initial activation of "UI Clim" can contribute to faster and more uniform heating of the room where it is installed.



"Auto 5"



Recommended settings for radiant panel systems with very large rooms.

During the activation phase, only the boiler provides heating through the emitters (radiant panels) located in the rooms in the area; after "Activation time" (120 min.) at the start of the next phase, "UI Clim" also turns on and contributes to heating the rooms in the area.

In "Auto 5", as with all suggested trial settings for radiant panel systems, the fan speed of UI Clim is set to minimum.

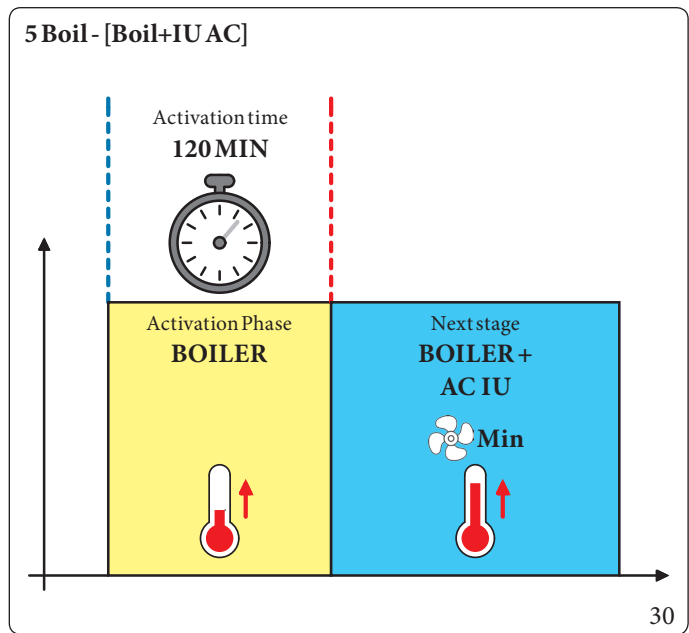

For example, this setting is recommended when the room(s) to be heated is/are very large and the simultaneous operation of the two generators, in a subsequent phase, can be useful in achieving more uniform heating.

"Auto 6"



Recommended settings for radiant panel systems with UI Clim near the controller.

During the activation phase, only "UI Clim" heats the air in the rooms in the zone; after "Activation time" (20 min) at the start of the next phase, "UI Clim" switches off and only the boiler switches on for heating via the emitters (radiant panels) in the rooms in the area.

This reduced "Activation time" and the exclusive operation of the boiler in the next phase ensure that all rooms in the area are heated when the hot air flow from the "UI Clim" only partially affects those rooms.

In "Auto 6", as with all suggested trial settings for radiant panel systems, the fan speed of "UI Clim" is set to minimum.

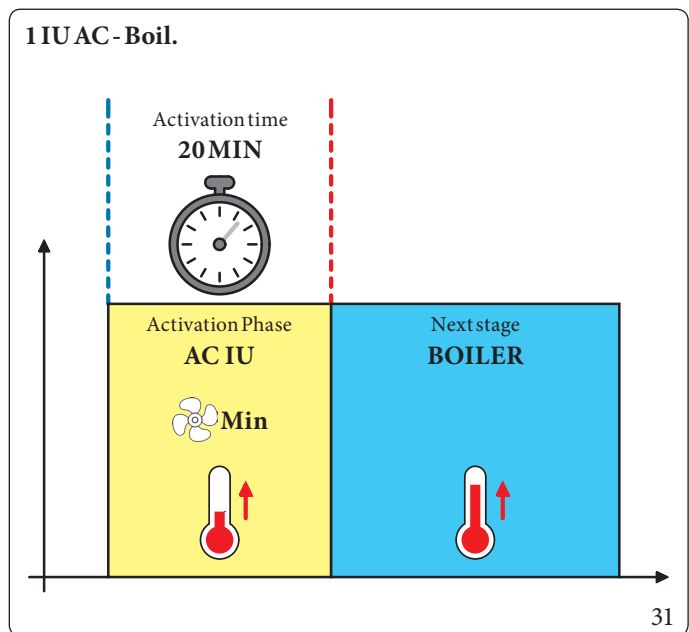

For example, this attempt setting is recommended in installations where the "UI Clim" is positioned very close to the controller, but the room(s) to be heated is/are very large or only partially affected by the air flow from the "UI Clim". In this installation, the minimum relative distance between "UI Clim" and the controller does not guarantee uniform heating of the rooms in the zone.

"Personal."

The "Auto" settings described above pre-set the values described in the "Setting Advanced" menu, described below.

Any change of parameters in the "Setting Advanced" menu will automatically configure the "Hybrid CH Syst. Mode" menu as "Personal".



2.3.1.2 Description of the "Setting Advanced" menu

The menu below can be used to modify the control settings of the installed air conditioning units.

ZONES/Zone 1/Settings/Hybrid system/C.H.	
Menu item	Variables
Setting Advanced	Activation time
	Set Ventil. CH ACIU
	Generator priority

Activation time

Using the variable shown below, you can set the duration of the activation phase; this phase begins when a request is received and continues for the set time. During this phase, the system uses the priority generator (or generators) until the set activation time expires. In the next phase, the generator (or priority generators) will be activated according to the settings made in the "Generator priority" parameter. The next phase has no time limit and continues until the system request is satisfied.

ZONES/Zone 1/Settings/Hybrid system/C.H./Setting Advanced	
Variable	Range
Activation time	5÷240 min

Set Ventil. CH ACIU

The variable shown below can be used to define the operating speed of the "UI Clim" fan; in "Auto" mode, the system automatically adjusts the speed to be maintained.

ZONES/Zone 1/Settings/Hybrid system/C.H./Setting Advanced	
Variable	Range
Set Ventil. CH ACIU	Auto Min Medium Max

Generator priority

The variable shown below can be used to set the priority generator and the generator that will start when the activation time expires. The values that can be set range from 1 to 6.

ZONES/Zone 1/Settings/Hybrid system/C.H./Setting Advanced	
Variable	Range
Generator priority	1÷6

Key:

1 IU AC - Boil.

2 IU AC - [Boil+IU AC]

3 [Boil+IU AC] - Boil

4 [Boil+IU AC] - IU AC

5 Boil - [Boil+IU AC]

6 Boil - IU AC

The generators (or generator) to the left of the hyphen ("-") correspond to the priority generators or the priority generator.

When brackets are present, it means that both generators can operate in that phase.

The control panel shows a legend with the alternation of generators to facilitate use by the user.



2.3.2 Cooling

Using the menu below, the user can define the operation of the system in cooling mode. Three distinct values can be set for the following parameter:

ZONES/Zone 1/Settings/Hybrid system/Cooling	
Menu item	Range
Hybrid Cool. Syst. Mode	Remote IU RoomT Digital

If you wish to use the “UI CLIM” remote control independently of the EUREKA hybrid system, you must select the parameter highlighted in the following menu.

For instructions on using the RF remote control and the application, refer to the paragraph 2.1.

ZONES/Zone 1/Settings/Hybrid system/Cooling	
Menu item	Parameter to be set
Hybrid Cool. Syst. Mode	Remote IU

If you want the hybrid system to operate in the same way as in heating mode, where requests to activate and deactivate the generators can come from the room thermostat, remote zone panel and/or wireless room probe, select the parameter highlighted in the menu below. If using a remote zone control or wireless room probe, a jumper must be installed on the room thermostat input in the associated zone.

ZONES/Zone 1/Settings/Hybrid system/Cooling	
Menu item	Parameter to be set
Hybrid Cool. Syst. Mode	RoomT

If you want the EUREKA hybrid system supervision to no longer take into account the status of the room thermostat, the temperature read by the wireless room probe or the remote zone panel to activate or deactivate a cooling request, select the parameter highlighted in the following menu:

ZONES/Zone 1/Settings/Hybrid system/Cooling	
Menu item	Description
Hybrid Cool. Syst. Mode	Digital

 In this mode, the use of “MAN Operating Mode” is prohibited. If activated, the cooling request remains active at all times and cannot be deactivated.

With this setting, the request to activate a UI CLIM will not be thermostatically controlled but managed exclusively by the calendar in digital mode (ON-OFF). Any UI CLIM associated with the zone in digital mode will be:

- always active in monitoring the environment and its temperature for the entire duration of the comfort temperature time slot;
- always off for the entire duration of the reduced temperature time slot.

The following setting is recommended in cases where:

- there is no room thermostat suitable for cooling management;
- the installation position of the controller is unfavourable for managing a cooling request.

For optimal use of the digital logic, it is necessary to set the system operating time slots from the "Clock and programs" menu; in this way, you can set the activation and deactivation of the “UI Clim” of the configured zone in line with your habits.

See paragraph 2.3 for more information.3 "Room setpoint settings (AUTO/MAN setting)" for setting the correct room sets.

 The room thermostat must be suitable for controlling the room demand during cooling; it must be of the reversible type. Also pay attention to any direct connections from the RT to zone valves/circulators, which must not be activated in cooling mode.



2.3.3 Room setpoint settings (AUTO/MAN setting)



Any cooling or heating request may be executed with a delay of approximately 60-90 seconds compared to the actual activation. This is not a malfunction but the normal initialisation process of the hybrid system integration logic.

If a wireless room probe or remote zone control is present:

The room setpoints can be set via the boiler control panel (UCIEUREKA) or, if present, via the remote zone control.

The above is always valid except for the “Hybrid Cool. Syst. Mode = Digital” mode where the “Set AUTO reduced” setting will not be available.



For further information, refer to the boiler instruction booklet (UCIEUREKA)

If room thermostats are present (e.g. CRONO7):

If the request to activate zone generators is made by an ON/OFF room thermostat, and if there are “UI Clim” associated with the specific zone, it is necessary and mandatory to set the same value as that set on the thermostat (e.g. 20 °C) in the dedicated menu, using the boiler control panel (UCIEUREKA).

The parameters to be set will be “Set AUTO comfort” or “Set MAN”; depending on the mode activated, the setting “Set AUTO reduced” will not be available.

2.4 PERMANENT SHUTDOWN



To permanently deactivate the system, refer to the instruction booklet for the boiler (UCIEUREKA) and the air conditioning indoor and outdoor units (UI THOR + UETHOR).



3 MAINTENANCE AND SERVICE.



For system maintenance, refer to the instruction booklet for the boiler (UCI EUREKA) and the air conditioning indoor and outdoor units (UI THOR+ UE THOR).

3.1 IMPLEMENTING



Commissioning the appliance requires you to:

- Check that the instructions in the boiler instruction booklet (UCI EUREKA) have been followed;
- Check that the instructions in the “UI Clim” indoor air conditioning unit instruction booklet (“UI THOR” instruction manual) have been followed.

3.2 FIRST IGNITION PARAMETER SETTING

3.2.1 Hybrid system definition

After checking that the interface board has been installed correctly (see paragraph 1.8), you need to configure some parameters using the “UCI EUREKA” control panel.

Using the menu below, you must configure the system according to the type of system installed and the user's requirements.

MENU / Support / Hybrid system	
Menu item	Description
System control	Enables the hybrid system and sets the operating limits relative to outdoor temperature

It is possible to provide fully centralised control and management via the hybrid system or to allow the user to control the “UI Clim” entirely via the App/Remote Control.

The two parameters are differentiated by mode (e.g. it will therefore be possible to activate the hybrid system exclusively in heating mode):

MENU / Support / Hybrid system / System control	
Menu item	Range
Hybrid CH enable	No - Yes
Hybrid cool. enable	No - Yes

If even one of the two parameters is active, it is obviously necessary, after assessing the position of the “UI CLIM” and the number of hydraulic zones in the system, to configure the air conditioning indoor units (“UI CLIM”) through the dedicated menu.

It is also necessary to configure an external temperature below which the operation of the “UI Clim” will be inhibited. This value must be set in the parameter of the menu shown below:

MENU / Support / Hybrid system / System control	
Menu item	Range
Min. CH integr. temp.	-20 ÷ 30 °C



Inhibiting the operation of the “UI Clim” will not interrupt the timer of the “Activation time” defined in the menu shown below.

ZONES/Zone 1/Settings/Hybrid system/C.H./Setting Advanced	
Variable	Range
Activation time	5 ÷ 240 min

The continuous comparison between the external temperature and “Min. CH integr. temp.” makes the use of the “UI Clim” generator available or not, but does not change the timing determined by the settings in the dedicated menus.



3.2.2 “UICLIM” configuration

The “UICLIM” configuration is carried out using the menu shown below:

MENU/Support/Hybrid system	
Menu item	Description
IU ACA	Allows the configuration and association of IU ACA
IU ACB	Allows the configuration and association of IU ACB
IU ACC	Allows the configuration and association of IU ACC



The settings below, referring to the "IU ACA" split can be applied in the same way or differentiated to the "IU ACB" and/or "IU ACC" split.

MENU/Support/Hybrid system/IU ACA	
Menu item	Description
Paired area	Set the hydraulic zone where the “UI Clim” is installed.
ACIU Address	Set the value corresponding to the address configured on the interface board using the switch (for more information, see par. 1.8)
CHACIU Offset	The parameters define the value that will be added to the set room setpoint (Set AUTO/Set MAN) and then transmitted to the “UI Clim”.
Cool. ACIU Offset	This setting can be useful for managing temperature stratification in the room and correcting the room setpoint value requested by the “UI Clim”.

It will be possible to check the actual communication with the “UI Clim” using the parameter “Search ACIU”; this function will activate the ventilation of the “UI Clim” to verify correct communication.

MENU/Support/Hybrid system/IU ACA	
Menu item	Range
Search ACIU	Stop Start

Each hydraulic zone can be associated with none, one or more “UI Clim”, however, the value set in the “AC IU Address” item must be unique and not replicated in other “UI Clim”.

3.2.3 Definition "Hybrid Cool. Syst. Mode/ Hybrid CH Syst. Mode"

To select and define the “Operating mode” of the hybrid system, refer to paragraph 2.3 "Setting the "Hybrid system" menu"; this paragraph indicates the possible selection available for each individual zone and the free modification also by the end user.

3.3 THERMOREGULATION DEVICE CONFIGURATION

3.3.1 Remote zone control

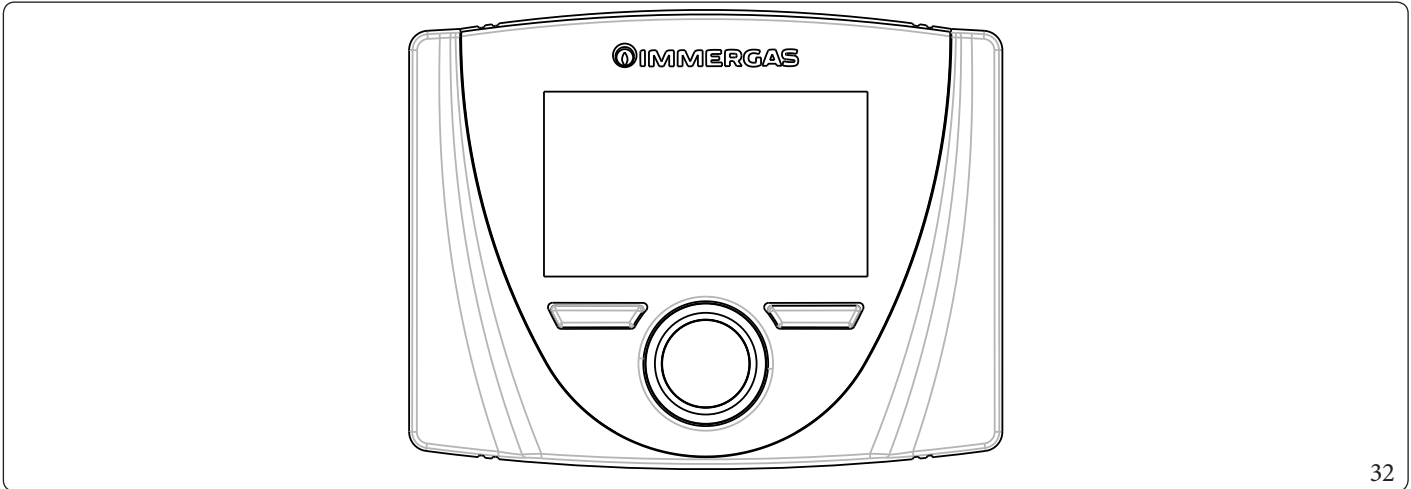

32

Assistance Menu -> Dev. configuration

Slave address: Address to configure according to the zone where the device is installed	Zone 1 = 41
	Zone 2 = 42
	Zone 3 = 43
Baud rate	9600
Parity bit	None
Stop bits	2

Activate the relevant "Panel Zx" parameter on the selected zone.

To enable the device on zone 1, set the parameter

Menu/Support/Modbus/Panel Z1 = Yes

To enable the device on zone 2, set the parameter

Menu/Support/Modbus/Panel Z2 = Yes

To enable the device on zone 3, set the parameter

Menu/Support/Modbus/Panel Z3 = Yes

i A system reboot is required after connecting the remote panel.
For correct operation it is necessary to install the link on the thermostat of the zone associated to the panel.
If necessary, this jumper can be replaced with a safety thermostat.

i The Remote Zone Panel is intended exclusively for setting the Zone Calendar and related room setpoints. Do not use the remaining parameters displayed.



3.3.2 Wireless room probe

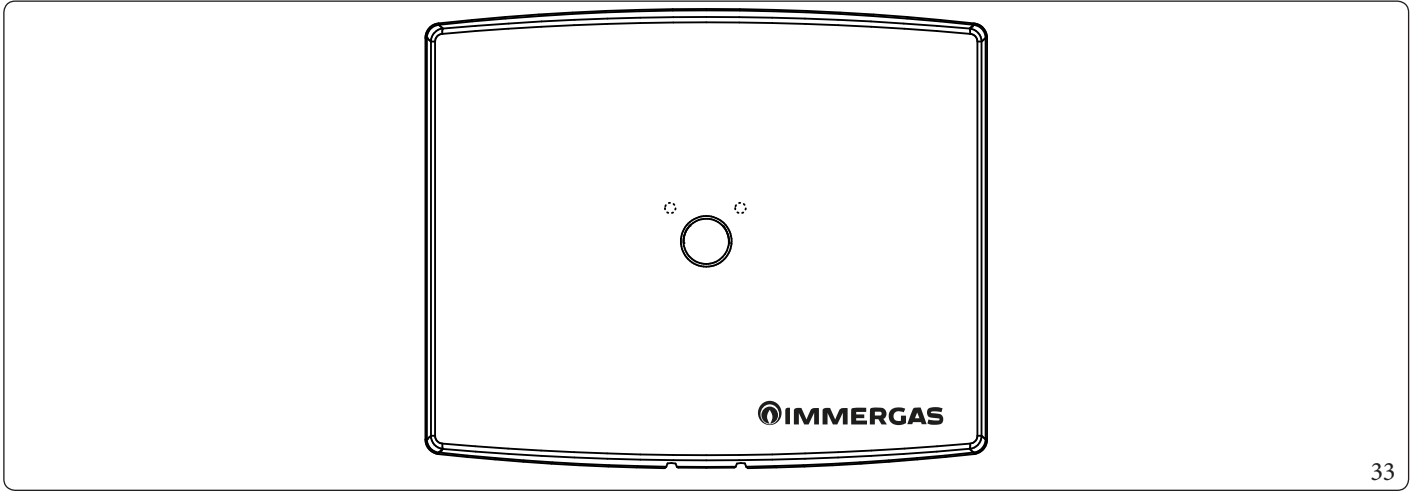

33

The configuration of the wireless room probe is shown in the menu below:

ZONES/Zone 1/Configuration/Room probe		
Menu item	Description	Range
Type	Makes it possible to select the type of probe to be associated with the zone in question	Off = No probe
		WIRED = Not used
		RF = Configuration to activate association with a wireless room probe
Address M3	During the association, it is necessary to enter the concentrator acknowledgement address (see dip-switch on concentrator)	0 ÷ 2
Status	This displays the association status with wireless probe (if installed)	Err = Association procedure failed
		No-Link = Probe cannot be reached via RF
		... (in config) = Probe association in progress
		Ok = Probe correctly associated

The parameters to be set are those shown in the example diagrams in the paragraph 1.11, and follow the procedure as indicated in the boiler instruction manual ("UCIEUREKA").

3.3.3 Dominus

To enable the Dominus device, use the parameter shown in the menu below:

MENU/Support/Modbus		
Menu item	Description	Range
Dominus	Enables communication to the Dominus device	No - Yes





