

RAPAX 100 V4

IE

Instructions and recommendations

Installer

User

Maintenance technician

Technical Data

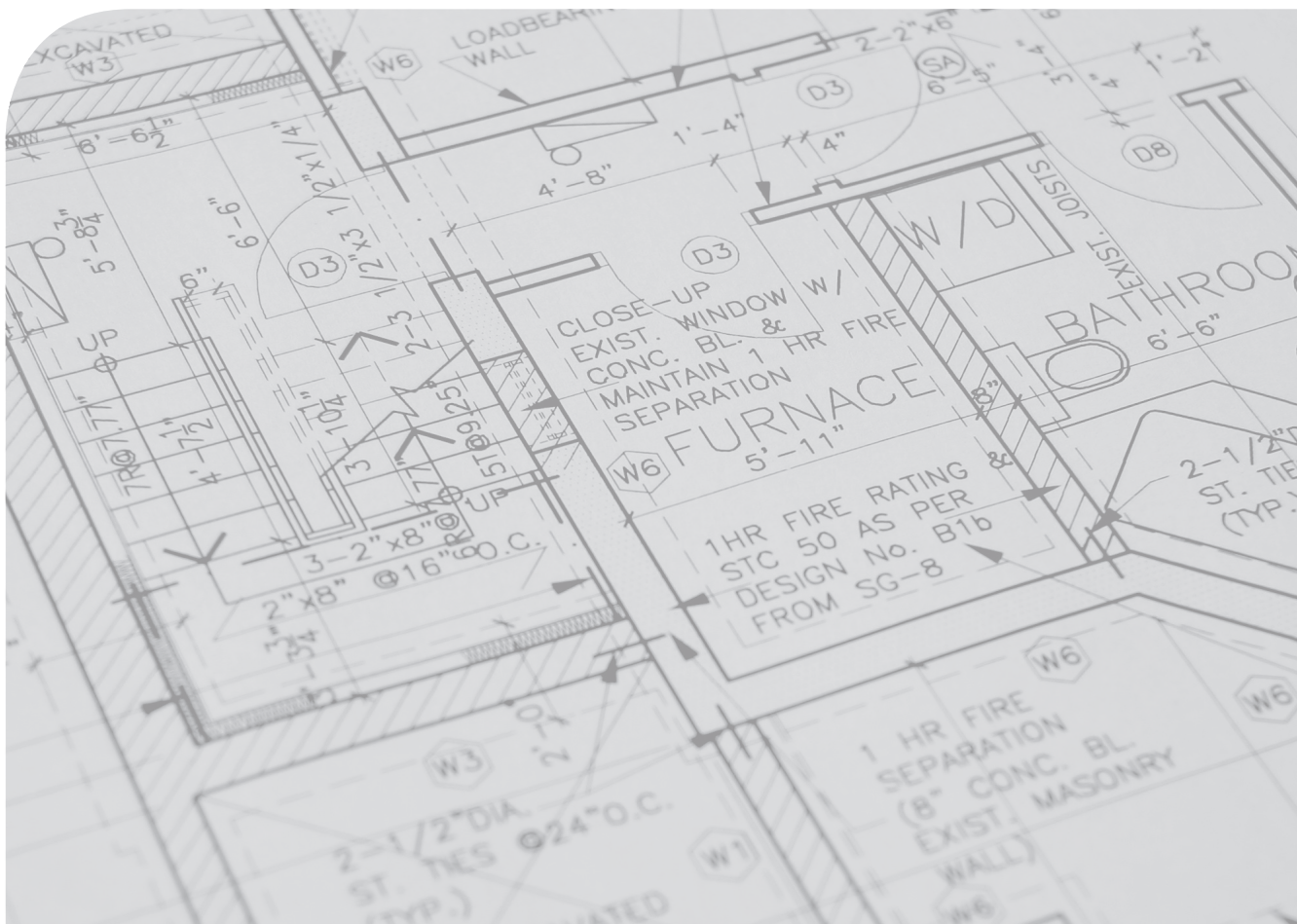

INDEX

Dear Customer.....	3
General Recommendations.....	3
Safety symbols used.....	5
Personal protective equipment	5
1 Unit installation	6
1.1 Installation warnings	6
1.2 Main components	10
1.3 Prior to installation.....	11
1.4 Unit installation	13
1.4.1 Minimum installation distances.....	13
1.4.2 Assembly dimensions.....	13
1.4.3 Main dimensions	15
1.4.4 Air duct connection	16
1.4.5 Electrical connection.....	20
1.4.6 Cold water connection.....	24
1.4.7 Hot water connection.....	24
1.4.8 Condensation evacuation	24
1.4.9 Installation checklist	26
1.5 Final inspections and test operation.....	27
1.5.1 Filling the tank with water before operation.....	27
1.5.2 Operation checks	28
1.5.3 Information on operation	28
2 Instructions for use and maintenance	31
2.1 General recommendations	31
2.2 Control panel.....	31
2.2.1 Description of the display.....	32
2.2.2 Description of control buttons.....	34
2.3 Operating mode	36
2.4 Appliance configuration with the Smartphone App.....	38
2.5.1 Download and install the App	38
2.5.2 User registration.....	39
2.5.3 Preparing for network configuration.....	40
2.5.4 Network configuration (automatic method).....	40
2.5.5 Network configuration (manual method).....	44
2.5.6 How to use the App.....	47
2.5.6.1 Operating mode.....	48
2.5.7 Special functions	49
2.5.8 Compliance.....	52
2.6 Fault and anomaly signals	53
2.7 Error codes.....	54
3 Instructions for maintenance and initial check.....	56
3.1 General recommendations	56
3.2 Appliance check and maintenance.....	56
3.3 List of ordinary maintenance operations	58
4 Technical data.....	59
4.1 Technical data table.....	59
4.2 Product fiche RAPAX 100 V4 (in compliance with Regulation 811/2013).....	61
4.3 DHW performance (EN16147) (RAPAX 100 V4)	61



Dear Customer

Congratulations for having chosen a top-quality Immergas product, able to assure well-being and safety for a long period of time. As an Immergas customer you can also count on a Qualified Authorised After-Sales Technical Assistance Centre, prepared and updated to guarantee the constant efficiency of your products. Read the following pages carefully: you will be able to draw useful tips on the proper use of the device, compliance with which will confirm your satisfaction with the Immergas product.

Please contact our Authorised Technical Service Centre in your area to request a free initial operation check (necessary for the **validation of the special Immergas's warranty**). Our technician will check the good working conditions of the appliance, make the necessary adjustments and explain the correct use. Furthermore, they will present to you the advantages of the "Formula Comfort" initiative, which includes an extension of the product warranty.

For assistance and routine maintenance, contact Authorised Technical Service Centres: they have original spare parts and are specifically trained directly by the manufacturer.

For assistance and routine maintenance, contact Authorised Technical Service Centres: they have original spare parts and are specifically trained directly by the manufacturer.

GENERAL RECOMMENDATIONS



This book contains important information for the:

Installer (section 1);

User (section 2);

Maintenance Technician (section 3).

- The user must carefully read the instructions in the specific section (section 2).
- The user must limit operations on the appliance only to those explicitly allowed in the specific section.
- The appliance must be installed by qualified and professionally trained personnel.
- The instruction booklet is an integral and essential part of the product and must be given to the new user in the case of transfer or succession of ownership.
- This manual must be stored with care and consulted carefully, as all of the warnings provide important safety indications for installation, use and maintenance stages.
- In compliance with legislation in force, the systems must be designed by qualified professionals. Installation and maintenance must be performed in compliance with the regulations in force, according to the manufacturer's instructions and by professionally qualified staff, intended as staff with specific technical skills in the system sector, as envisioned by the Law.
- Improper installation or assembly of the Immergas appliance and/or components, accessories, kit and devices can cause unexpected problems to people, animals and objects. Read the instructions provided with the product carefully to ensure proper installation.
- This instruction manual provides technical information for installing Immergas products. As for the other issues related to the installation of products (e.g. safety at the workplace, environmental protection, accident prevention), it is necessary to comply with the provisions of the standards in force and the principles of good practice.
- All the Immergas products are protected with suitable transport packaging.
- The material must be stored in a dry place protected from the weather.
- Damaged products must not be installed.
- Maintenance must be carried out by skilled technical staff. For example, the Authorised Service Centre that represents a guarantee of qualifications and professionalism.
- The appliance must only be destined for the use for which it has been expressly declared. Any other use will be considered improper and therefore potentially dangerous.
- If errors occur during installation, operation and maintenance, due to non-compliance with technical laws in force, standards or instructions contained in this booklet (or however supplied by the manufacturer), the manufacturer is excluded from any contractual and extra-contractual liability for any damages and the device warranty is invalidated.
- In the event of malfunctions, faults or incorrect operation, turn the appliance off and contact an authorised company (e.g. the Authorised Technical Assistance Centre, which has specifically trained staff and original spare parts). Do not attempt to modify or repair the appliance alone.



IMPORTANT

Thermal systems must undergo periodic maintenance and scheduled checks of the energy efficiency in compliance with national, regional or local provisions in force.

The company **IMMERGAS S.p.A.**, with registered office in via Cisa Ligure 95 42041 Brescello (RE), declares that the design, manufacturing and after-sales assistance processes comply with the requirements of standard **UNI EN ISO 9001:2015**.

For further details on the product CE marking, request a copy of the Declaration of Conformity from the manufacturer, specifying the appliance model and the language of the country.

The manufacturer declines all liability due to printing or transcription errors, reserving the right to make any modifications to its technical and commercial documents without forewarning.



SAFETY SYMBOLS USED



GENERIC HAZARD

Strictly follow all of the indications next to the pictogram. Failure to follow the indications can generate hazard situations resulting in possible harm to the health of the operator and user in general, and/or property damage.



ELECTRICAL HAZARD

Strictly follow all of the indications next to the pictogram. The symbol indicates the appliance's electrical components or, in this manual, identifies actions that can cause an electrical hazard.



WARNING FOR INSTALLER

Read the instruction booklet carefully before installing the product.



WARNINGS

Strictly follow all of the indications next to the pictogram. Failure to follow the indications can generate hazard situations resulting in possible minor injuries to the health of both the operator and the user in general, and/or slight material damage.



ATTENTION

Read and understand the instructions of the appliance before carrying out any operation, carefully following the instructions given. Failure to observe the instructions may result in malfunction of the unit.



A3

COMBUSTIBLE MATERIAL WARNING

This symbol indicates that the appliance in question uses a flammable refrigerant. If refrigerant leaks and is exposed to an external ignition source, there is a risk of fire.



INFORMATION

Indicates useful tips or additional information.



EARTH TERMINAL CONNECTION

The symbol identifies the appliance's earth terminal connection point.



DISPOSAL WARNING

The user must not dispose of the appliance at the end of its service life as municipal waste, but send it to appropriate collection centres.

PERSONAL PROTECTIVE EQUIPMENT



SAFETY GLOVES



EYE PROTECTION



SAFETY FOOTWEAR



1 UNIT INSTALLATION

1.1 INSTALLATION WARNINGS



Operators who install and service the appliance must wear the suitable personal protective equipment required by applicable law.



The installation of the appliance must be carried out by qualified personnel in compliance with current local regulations and the instructions in this manual. Improper installation may cause water leakage, electric shock or fire. Qualified personnel means: qualified plumbers, personnel from authorised electrical companies, and authorised service personnel.



- **Before use, this appliance requires proper earthing, failure to do so may result in serious injury or death.**
- **The appliance must be installed in compliance with current local regulations for electrical systems.**
- **Proper earthing and installation of the appliance must be carried out by qualified personnel. This appliance should not be installed unless you are sure that the power supply to your home is properly earthed.**
- **Electrical connection work must be carried out in compliance with current local regulations and the instructions in this manual.**



The maximum refrigerant charge quantity is 0.15 kg.

Application limit



This product is suitable for domestic use only, for preparing domestic hot water at 38-70°C. It must be connected to the domestic water supply and electricity supply systems. It is prohibited to use the equipment for other purposes such as industrial production, or to install it in an environment exposed to risks of corrosion and combustion.

The manufacturer is not responsible for damage to the equipment due to incorrect installation or improper use.

Installation warning



- Make sure that the wall on which the appliance will be installed is suitable to support the weight of the appliance and its water contents. A structural check by the home designer is recommended.
- If the boiler is to be mounted in a false ceiling, under the roof or above a living area, it is mandatory to install a collection tray to be connected to the drain.
- Before carrying out any work on electrical or hydraulic systems, check the safety of the installation area (walls, floors, etc.) and that it is not exposed to risks deriving from the presence of water, unprotected electrical parts, and gas.
- Place the appliance in an accessible location.
- Do not leave flammable materials in contact with or near the appliance.
- If the appliance has an auxiliary electric heater, this must be installed at least 1 metre away from combustible materials.
- Install the appliance in a room protected from temperatures that can drop below 0°C. The warranty does not cover damage to the appliance due to excessive pressure caused by a blockage of the one-way valve.
- If the appliance is to be installed in a room with an ambient temperature exceeding 35°C, this room must be ventilated.
- The installed appliance must be securely fixed.
- Take lightning protection measures in the building in accordance with local legislation and/or ENV 61024-1 to ensure safe operation of the appliance.



Electrical system



- The electrical system must be installed by professional technicians and must comply with both current local regulations and the wiring diagram.
- The appliance must be effectively earthed. It is mandatory to install a safety device on the power supply line.
- Before proceeding with the installation, verify that the user's power supply line meets all the requirements of the appliance (including proper earthing, voltage drop protection, wire diameter, electrical load, etc.). If the electrical installation requirements of the appliance are not met, installation of the appliance is prohibited until the system is modified.
- The installation height of the wall socket, if used, must be greater than 1.8 m. If there is a risk of splashing water, separate the power supply unit from the water.
- Never use cables and fuses other than those recommended by the manufacturer; otherwise the appliance may malfunction and cause a fire.
- To avoid danger due to inadvertent resetting of the thermal switch, this appliance must not be powered through an external switching device, such as a timer, or connected to a circuit that is regularly turned on and off by the user.
- When several appliances are installed in a centralised manner, check the balancing of the three-phase power load and do not allow multiple appliances to be assembled on the same power supply phase.

Hydraulic connection



- The temperature of the water entering the appliance must not be lower than 4°C; the maximum temperature of the water produced by the appliance may be higher than 70°C.
- It is mandatory to install a domestic water vessel sized according to the heated volume and the temperature difference (between 4 and 70°C) of the water entering the appliance. This installation is intended to avoid possible openings of the safety valve.
- The minimum water pressure in the supply pipe system is 0.15 MPa. If the pressure exceeds 5 bar (0.5 MPa), it is necessary to fit a pressure reducer (not supplied) positioned on the main supply line.
- Connect the appliance to a drain pipe, using a pressure reducer, in a protected area where temperatures can drop below 0°C and with an adequate and constant downward slope. The drain pipe connected to the safety device must be installed with a continuous downward slope and in a frost-free environment. The purpose is to eliminate excess water that is produced due to expansion during heating.
- An incorrectly constructed draining system can cause flooding of the building, furniture, etc.
- A one-way valve, included in the supply, must be installed on the water inlet side (see par. 1.3).
- Do not connect hot water pipes directly to copper pipes. The pipes must be equipped with special fittings (not included in the supply).
- It is mandatory to screw a suitable pressure relief device onto the appliance's water inlet pipe; the pressure relief device must be operated regularly to remove limescale deposits and ensure it is not blocked. In countries that recognise the EN 1487 standard, the water supply pipe to the appliance must be equipped with a safety device compliant with this standard; it must be calibrated to a maximum pressure of 0.75 MPa and must include at least a tap, a check valve, a one-way valve and a device for interrupting the hydraulic load.



If an open chamber boiler and a heat pump with unducted or unsealed vents are operated simultaneously, a strong vacuum could be created in the room; this vacuum can cause boiler exhaust gases to be sucked back into the room. Avoid operating the heat pump at the same time as an open chamber boiler. Use only approved sealed combustion chamber boilers with separate combustion air supply. Install a protective grille at both the inlet and outlet air vent connections to prevent foreign bodies from entering the equipment.

Operation warning



- **Make sure the earthing of the power outlet where the appliance will be connected is properly connected; make sure the power outlet and plug are sufficiently dry and firmly connected.**
- **Check that the socket and plug used to connect the power supply comply with current regulations and are suitable for supporting the product's loads.**





- Do not turn off the power supply; the antifreeze protection remains active in "Stand-by" mode.
- The appliance requires an adequate and continuous power supply for operation; the appliance switches on and off automatically according to the settings made on the control panel.
- Do not operate the appliance with wet hands. Danger of electric shock.
- Water heated above 50°C can cause serious burns if poured directly from taps. Children, disabled people and the elderly are particularly at risk. It is recommended to install a mixing valve on the system at the hot water outlet. Check the water temperature before bathing or showering.



- Do not insert fingers, sticks, or other objects into the air inlet or outlet. Be careful of the fan, which, rotating at high speed, can cause injury.
- Never use flammable sprays such as hairspray, fixatives or paints near the appliance. May cause fire.
- If the power cable is damaged, it must be replaced by the manufacturer or by a service technician or by a technician authorised to perform these operations.
- Do not leave packaging materials (paper clips, plastic bags, expanded polystyrene, etc.) within the reach of children; they can cause serious injury.
- After a long period of use, check the base and fittings of the appliance. If damaged, the appliance may fail and cause injury to the user.
- Do not touch the internal parts of the control panel.
- Do not disassemble the front panel. Some internal parts are dangerous if touched and may cause the appliance to malfunction.
- To preserve the duration of appliance efficiency features, in the presence of water whose characteristics can lead to the deposit of lime scale, installation of the "polyphosphate dispenser" kit is recommended.



- **Activating the safety switch (1 Fig. 18) indicates a potentially dangerous situation. Do not reset the switch until the water heater has been repaired by qualified personnel.**
- **Continuous water leakage from the valve may indicate a problem or fault within the water heater.**



If the appliance is not used for a long period of time (2 or more weeks), a small amount of hydrogen may form in the water pipe due to chemical reactions. Hydrogen is an extremely flammable gas. Under such conditions, to reduce the risk of injury, it is recommended to open the hot water tap in the kitchen sink for several minutes before using any electrical appliance connected to the hot water system. In the presence of hydrogen, you are likely to hear an unusual noise, like air escaping from a pipe when water begins to flow. When opening the tap, there must be no smoke or open flames near it.



Operating attention



- Do not remove, cover, or deface any permanent information such as instructions, general labels, or data labels located on the outside of the appliance or inside the panels.
- It is normal for water to leak from the pressure relief device or EN 1487 safety device while the appliance is heating up. For this reason, it is necessary to install a drain, open to the air, with a pipe that slopes constantly downwards, in an area not subject to temperatures below zero. A condensate drain must also be connected to the same pipe with a special fitting.
- Be sure to empty the appliance when it is taken out of service in an area subject to temperatures that cannot drop below freezing.
- For the water draining procedure, see the following paragraphs of the manual.
- SMART mode is not recommended when water consumption is low or irregular. SMART mode analyses your water consumption habits so that the unit heats the water in advance to be ready based on your usage habits. This means that if usage is low and irregular, it is difficult to program recharges with a sort of self-learning system.
- After prolonged use, check the base and fittings of the appliance. If damaged, the appliance may fall, break and cause injury to the user.
- During holidays, do not disconnect the power supply and turn off the appliance but use the holiday mode (VACATION). If the appliance is switched off during long periods of non-use, please note that there will be no antifreeze protection. Take the necessary measures to prevent corrosion or freezing, such as emptying the appliance.
- Before installing, check that the available power supply meets all the requirements of the appliance (including proper earthing, leakage protection, cable diameter, electrical load, etc.). If the electrical installation requirements of the appliance are not met, installation of the appliance is prohibited until the system is modified.
- When several appliances are installed in a centralised manner, check the balancing of the three-phase power load and prevent multiple appliances from being connected to the same power supply phase.
- The appliance must be installed by fixing it securely to the wall and, if necessary, taking additional reinforcement measures.
- A one-way valve, included in the supply, must be installed on the water inlet side (see par. 1.3).



This product should not be disposed of with unsorted municipal waste at the end of its life. The used device must be returned to the municipal collection point for recycling together with electrical/electronic devices. For information on where to find a collection point, please contact your local authorities or contact the retailer where you purchased the product. Correct disposal of used appliances helps prevent potential harm to the environment and human health.



1.2 MAIN COMPONENTS



All images in this manual are for explanatory purposes only. They may be slightly different from the heat pump water heater you purchased (depending on the model). Please refer to the actual sample instead of the picture in this manual.

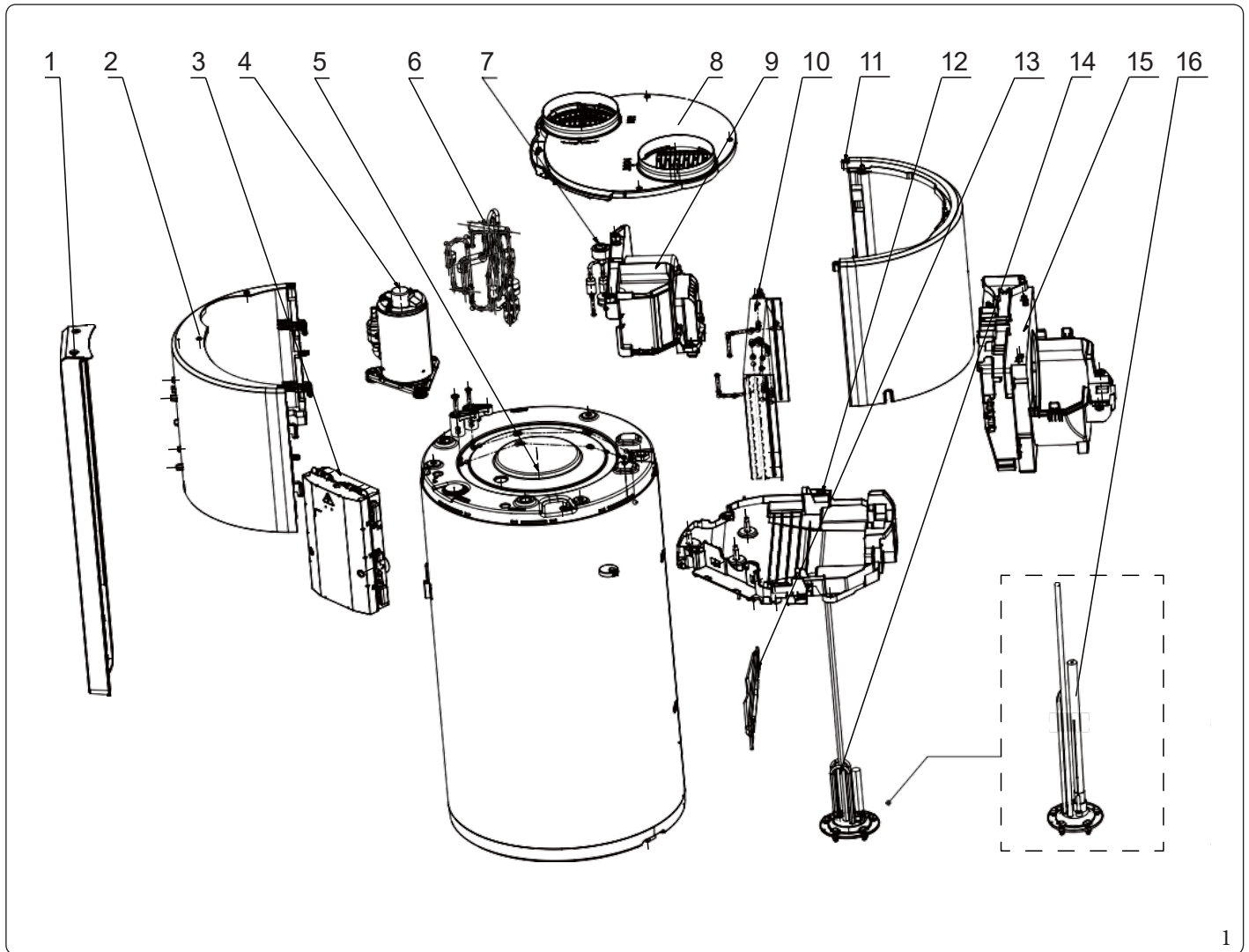



Key (Fig. 1):

- | | | | | | |
|---|---|----------------------------|----|---|--|
| 1 | - | Front panel | 9 | - | Upper panel |
| 2 | - | Front cover plate | 10 | - | Evaporator |
| 3 | - | Control panel | 11 | - | Black cover panel |
| 4 | - | Compressor | 12 | - | Drain pan |
| 5 | - | Water tank | 13 | - | Fixing bracket |
| 6 | - | 4-way valve | 14 | - | Heating element with anode |
| 7 | - | Electronic expansion valve | 15 | - | Fan unit |
| 8 | - | Upper panel | 16 | - | Resistance with electronic anode (not available on this model) |

1.3 PRIOR TO INSTALLATION.

Unpacking

1. Accessories

Accessory name	Qty	Provided	Purpose
User manual and Installation manual	1		Instructions for installing and using the appliance
One-way valve (G1/2") with integrated safety valve (0.75 MPa)	1		Prevent tank overpressure and ensure unidirectional water flow
Expansion plug	4		Fix the appliance

2. How to transport

- To avoid damaging the appliance, apply protective panels to the contact surface. Avoid contact of hands or other objects with the fins of the appliance. Do not tilt the appliance more than 75° when moving it and keep it vertical during installation.
- The appliance is heavy and must be transported by two or more people, otherwise it could get damaged and cause injury to the operator.

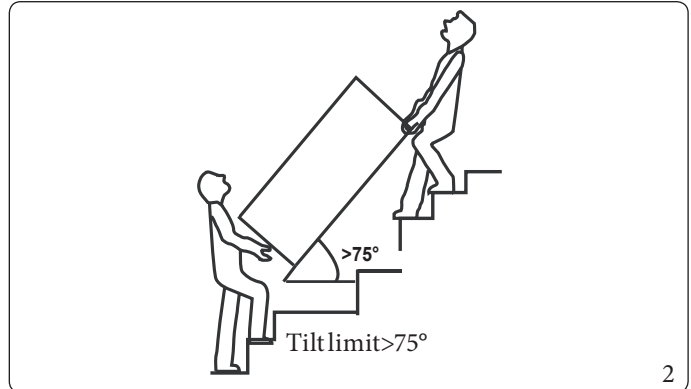

Position requirements

- Sufficient space must be provided for the installation and future maintenance of the appliance.
- Make sure that air can enter and exit the room freely, without anything obstructing its passage and avoid the presence of strong winds.
- The wall surface must be flat, with a maximum inclination of 2° and capable of supporting the weight of the appliance. It must also be able to not generate a higher than normal level of noise or vibrations.
- The noise generated by the operation of the appliance and the expelled air flow must not disturb the neighbours.
- The presence of flammable gas in the vicinity of the installation site is absolutely prohibited.
- The location chosen for installation must allow for simple and easy electrical connections and wiring.
- If the appliance is installed indoors, this may cause a decrease in temperature and an increase in noise. Please take preventative measures to manage these potential problems.
- If the appliance is installed on a metal building structure, ensure that the electrical insulation is adequate and complies with local electrical regulations.



- The ambient temperature of the room must also be taken into account when installing the appliance. In heat pump mode, the inlet air temperature must be above -7°C and below 43°C. When the outside air temperature is outside these limits, the heat pump stops operating. In these cases the electric heater is activated, which heats the water
- The appliance must be placed in an area where the temperature does not fall below 0°C. If the appliance is installed in areas where the temperature can drop below freezing or in unheated areas (for example, a garage or cellar), it may be necessary to insulate the water pipes, condensate pipes, and drain pipes. This insulation is essential to prevent pipes from freezing.





Installing the appliance in one of the following locations may result in malfunction; if it is necessary to install it in one of these locations, it is mandatory to consult the supplier beforehand.

- The room contains mineral oils as lubricants for cutting machines.
- Seaside locations, characterized by air with a high concentration of salt.
- Thermal areas where corrosive gases, such as sulphurous gas, are present.
- Factories where the supply voltage is subject to continuous variations.
- Inside a caravan or camper.
- Rooms exposed to direct sunlight or other heat sources. If this cannot be avoided, install an adequate cover.
- Rooms such as the kitchen where oily vapours can permeate inside the appliance.
- Rooms where there are strong electromagnetic waves.
- Rooms where there are gases or flammable materials.
- Rooms where there are acid or alkaline gases.
- Any other environment that presents special or risky conditions.



- **The appliance must be fixed securely, otherwise it may vibrate, causing noise and shock.**
- **Make sure there are no obstacles preventing access to the appliance.**
- **In places subject to strong winds (for example seaside locations), it is necessary to install the appliance in a place protected from the wind.**



1.4 UNIT INSTALLATION

1.4.1 Minimum installation distances

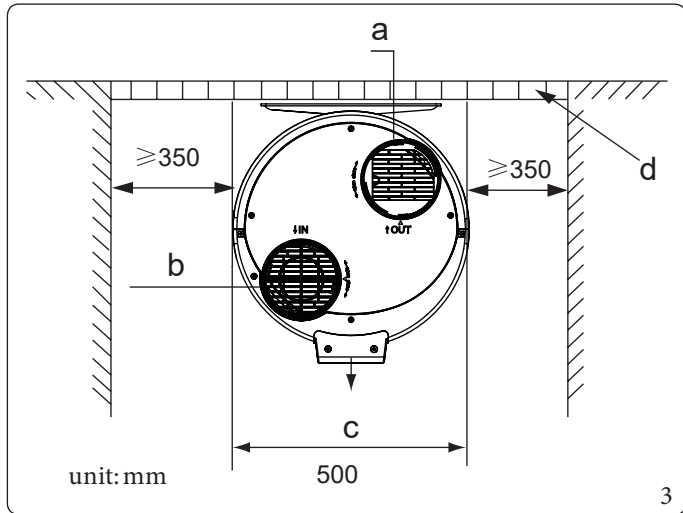

Key (Fig. 3):

- a - Air outlet
- b - Air inlet
- c - Display
- d - Wall

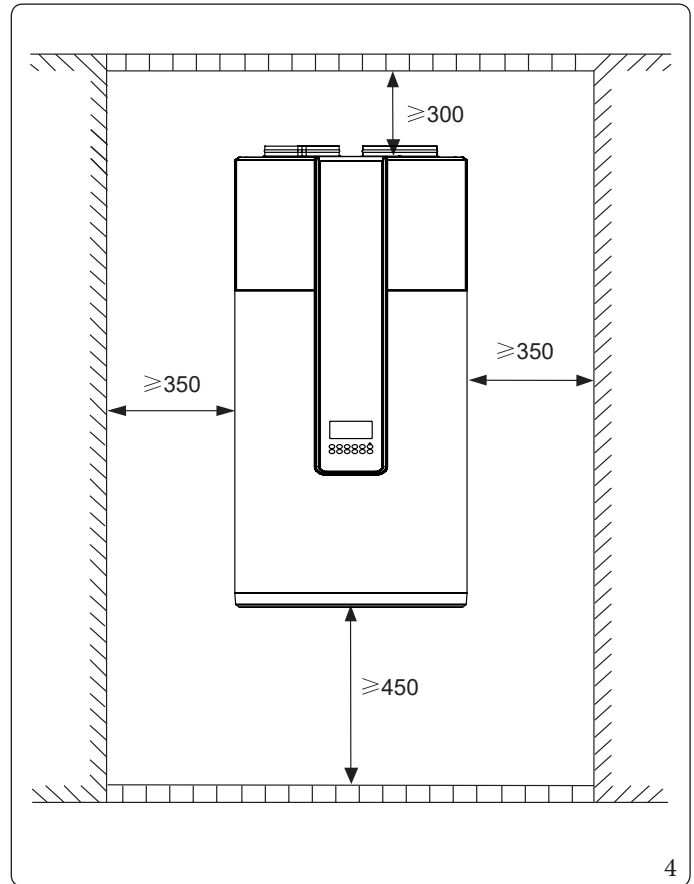

1.4.2 Assembly dimensions

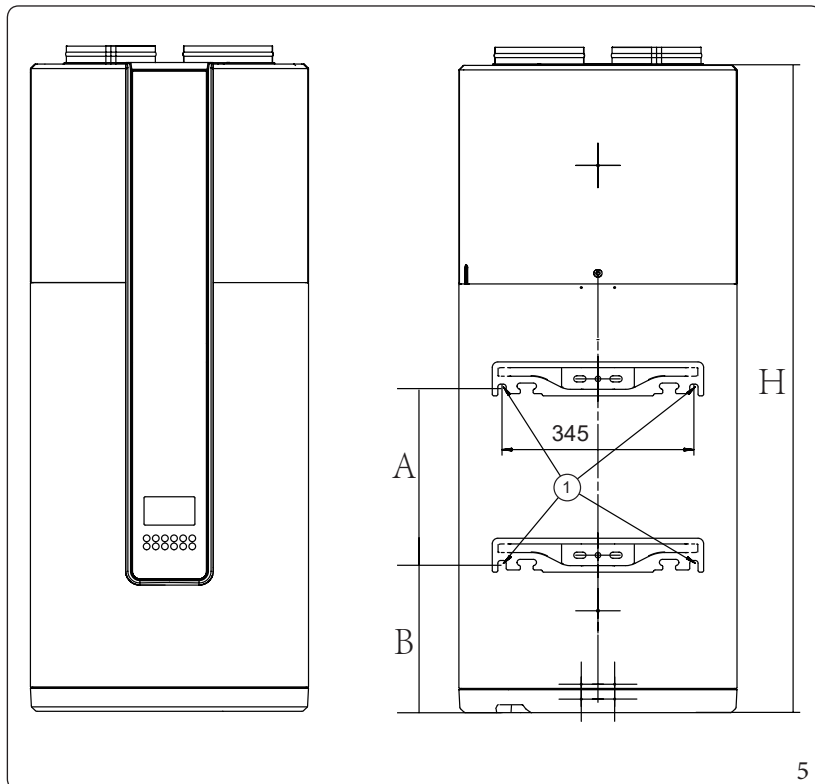

Key (Fig. 5):

- 1 - Installation holes

Dimensions		Rapax 100 V4
A	mm	415
B	mm	277
H	mm	1333

- Install the water heater in a room protected from temperatures that may drop below 0°C.
- Install the water heater as close as possible to the most frequently used draw points.
- Make sure that the wall on which the appliance will be installed is suitable to support the weight of the appliance and its water contents.

INSTALLER

USER

MAINTENANCE TECHNICIAN

TECHNICAL DATA



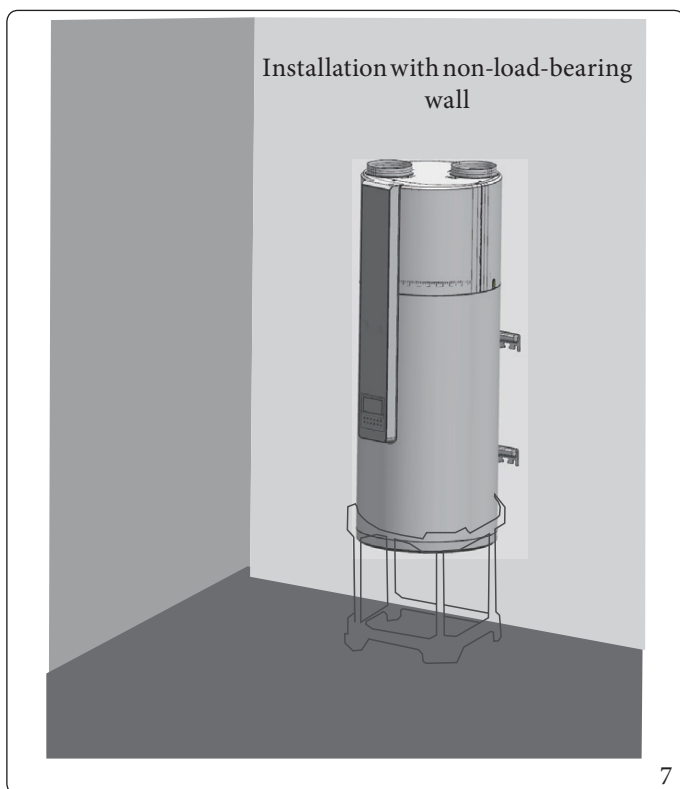
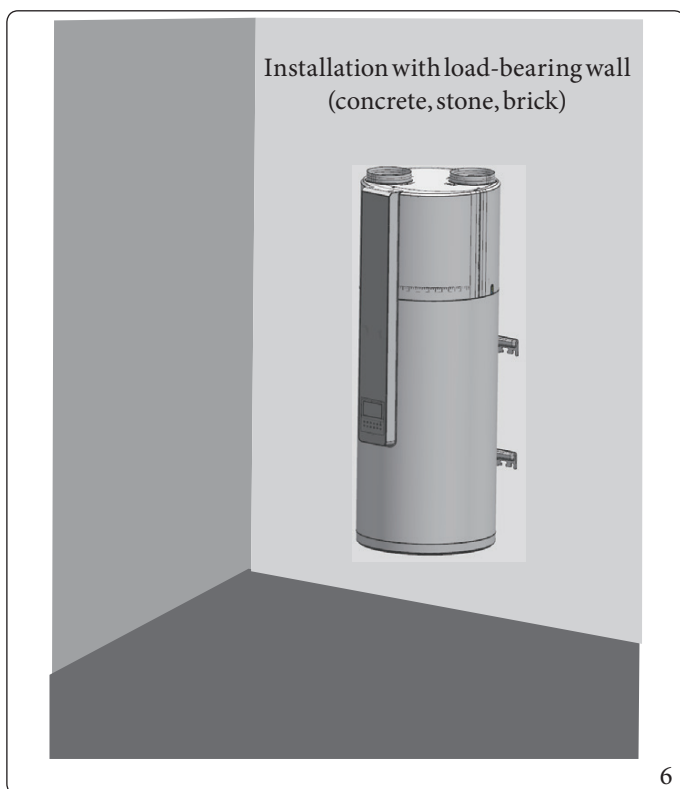

Mark the wall referring to the installation size requirements (Fig. 5). Tighten the \varnothing 10 mm bolts. The wall must be able to support a minimum load of 300 kg.

It is mandatory to install the water heater using a special support (not supplied with the appliance). To accurately mark the points where the holes are to be drilled, place the water heater on the bracket. Drill the holes and place the water heater in its final position. The fixing system must have a minimum diameter of 10 mm and be suitable for the type of wall on which it is installed.

The size of the hole for fixing the appliance to the wall should refer to the size of the corresponding hole displayed in Fig. 8 (two supports for each water tank, for a total of four expansion plugs).

After the plug has been tightened, check that the distance between the inside of the plug and the wall surface is between 15 and 17 millimetres, as shown in the image 8.

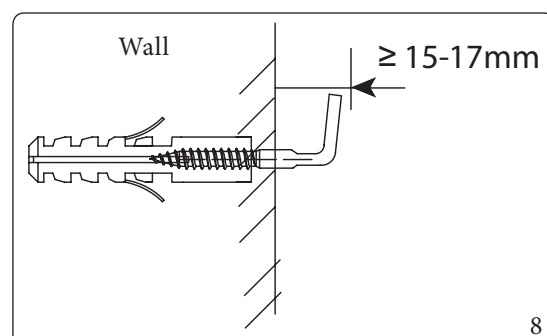

1.4.3 Main dimensions

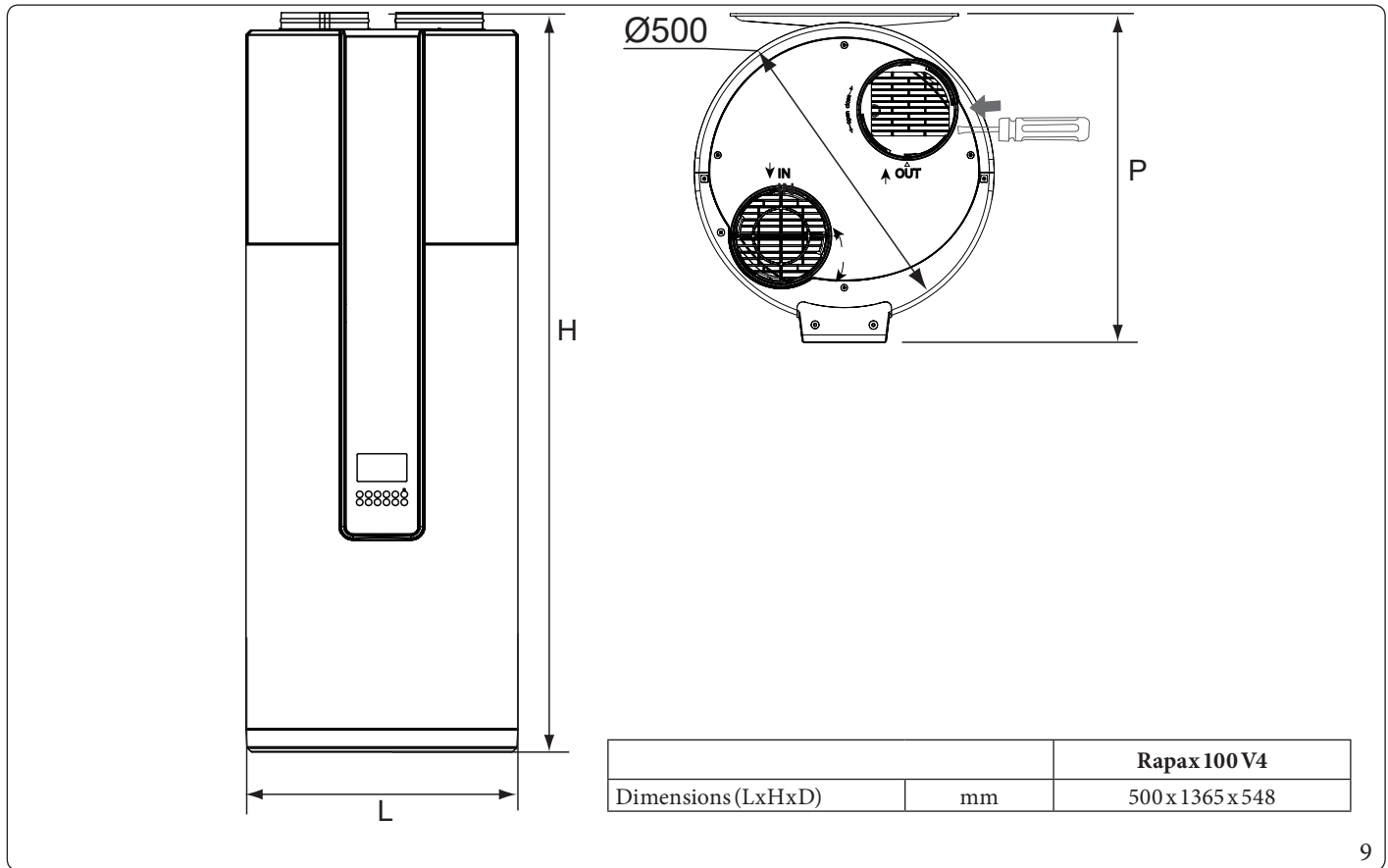

9



Use appropriate tools to disassemble and clean the filter.

INSTALLER

USER



MAINTENANCE TECHNICIAN

TECHNICAL DATA

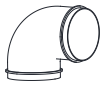

1.4.4 Air duct connection

It is important that the total pressure loss inside the pipes and components for air inlet and outlet is not greater than 80 Pa. It is recommended to use rigid ducts and to check that their length complies with the indications given in the specific manual of the appliance. The table below shows the relationship between the pressure drop of various components and their equivalent lengths.

		1m straight PVC/HDPE pipe	PVC/HDPE 90° elbow	Filter
Type				
RAPAX 100 V4 (Ø160)	Pressure drop (Pa)	1.0	3.3	6.2
	Equivalent length (m)	1.0	3.3	6.2

You need to enter the Configuration mode and set parameter F40 according to the calculated pressure drop, as shown in the table below.

Total pressure drop	0-20 Pa	20-40 Pa	40-60 Pa	60-80 Pa
F40	0	1	2	3



- The decrease in pressure inside the ducts will cause a reduction in the amount of air that can circulate.
- Condensation may form on the outside surface of the ducts, especially the air exhaust ducts. Alternatively, if you install standard ducts, you will need to insulate them to ensure the appliance's proper thermal efficiency.
- When the appliance is placed in a dirty or dusty room, it is necessary to install a filter at the air vent inlet of the appliance. If the appliance is connected to a duct system, the filter must be positioned at the entrance to the duct. Under normal environmental conditions, where the air is not particularly dirty, it is sufficient to install a simple grille to prevent the entry of foreign bodies.

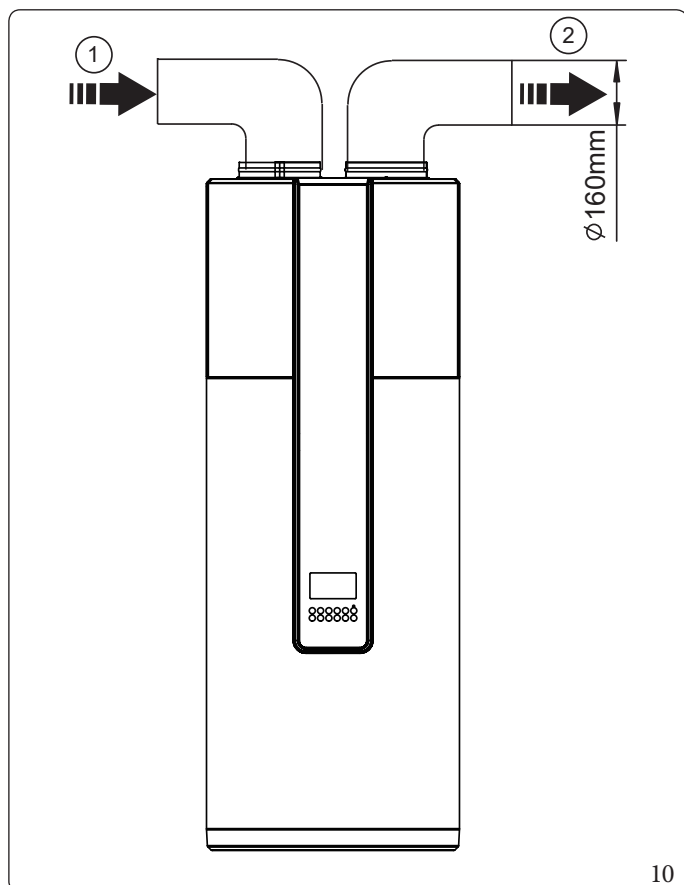

Air inlet (1) and outlet (2) with duct (Fig. 10)

Key (Fig. 10):

- 1 - Air inlet
- 2 - Air outlet



For the maximum length of the ducts, refer to the table "Air duct connection procedure" on page 18.



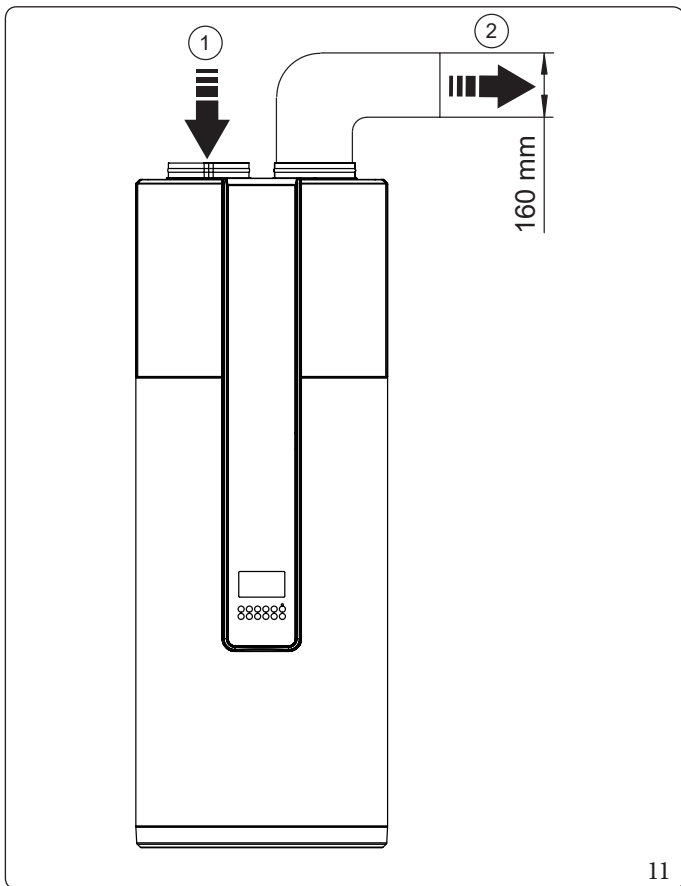

11

Air inlet (1) without duct; air outlet (2) with duct (Fig. 11)

Key (Fig. 11):

- 1 - Air inlet
- 2 - Air outlet



For the maximum length of the ducts, refer to the table "Air duct connection procedure" on page 18.



Install the appliance in this mode in winter and only if there is another heating source in the room.

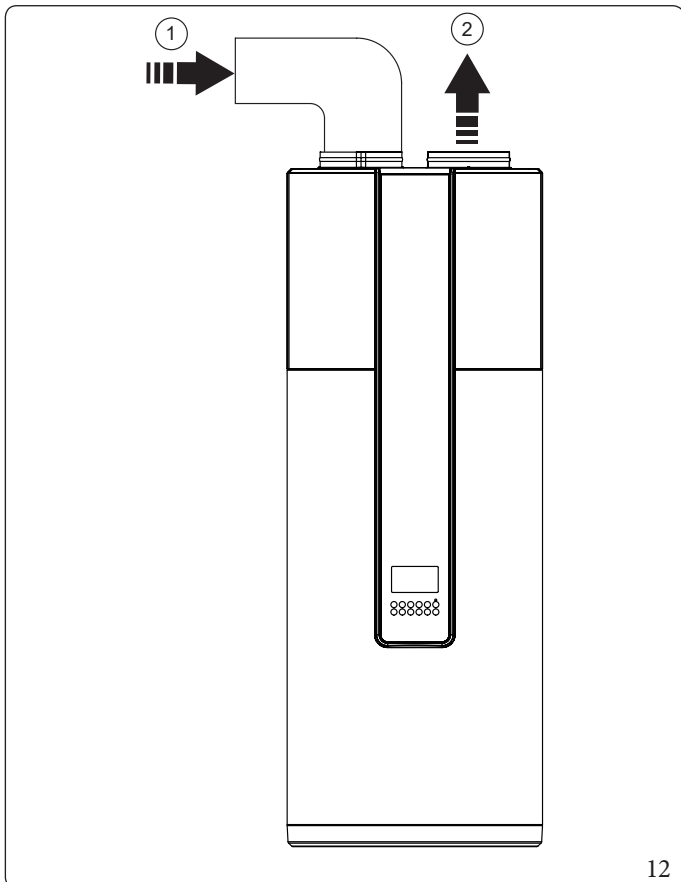

12

Air inlet (1) with duct; air outlet (2) without duct (Fig. 12)

Key (Fig. 12):

- 1 - Air inlet
- 2 - Air outlet



For the maximum length of the ducts, refer to the table "Air duct connection procedure" on page 18.



Install the appliance in this mode in the summer with the aim of introducing cooler air into the room.

INSTALLER

USER

MAINTENANCE TECHNICIAN

TECHNICAL DATA

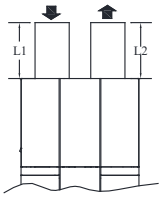
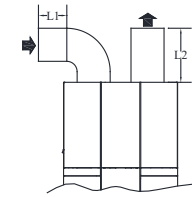
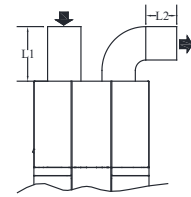
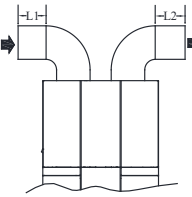

Air duct connection procedure

Type					
RAPAX 100 V4	Maximum pipe length L1+L2 (without filter)	60 m	56 m	56 m	53 m

Air duct connection directions

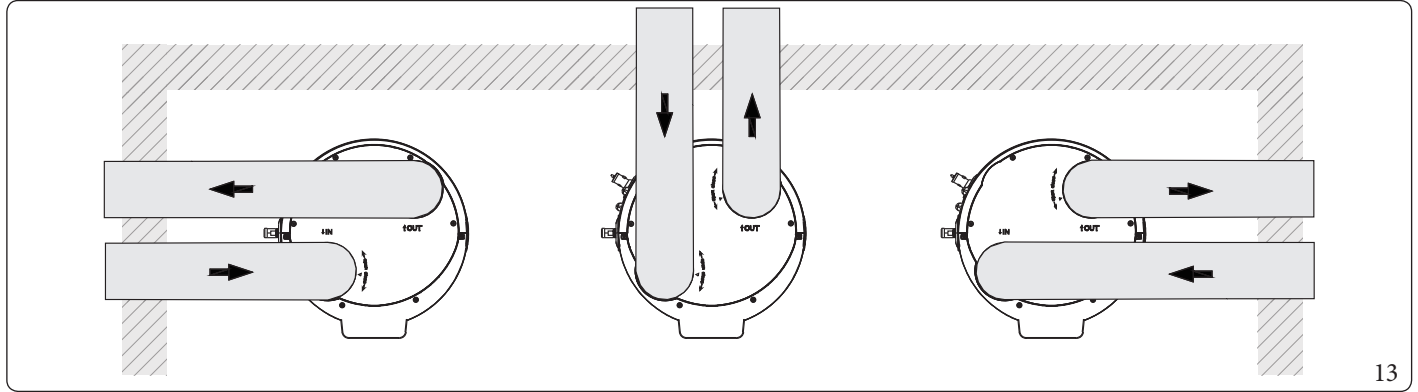

13

Minimum distance between air inlet/outlet ducts

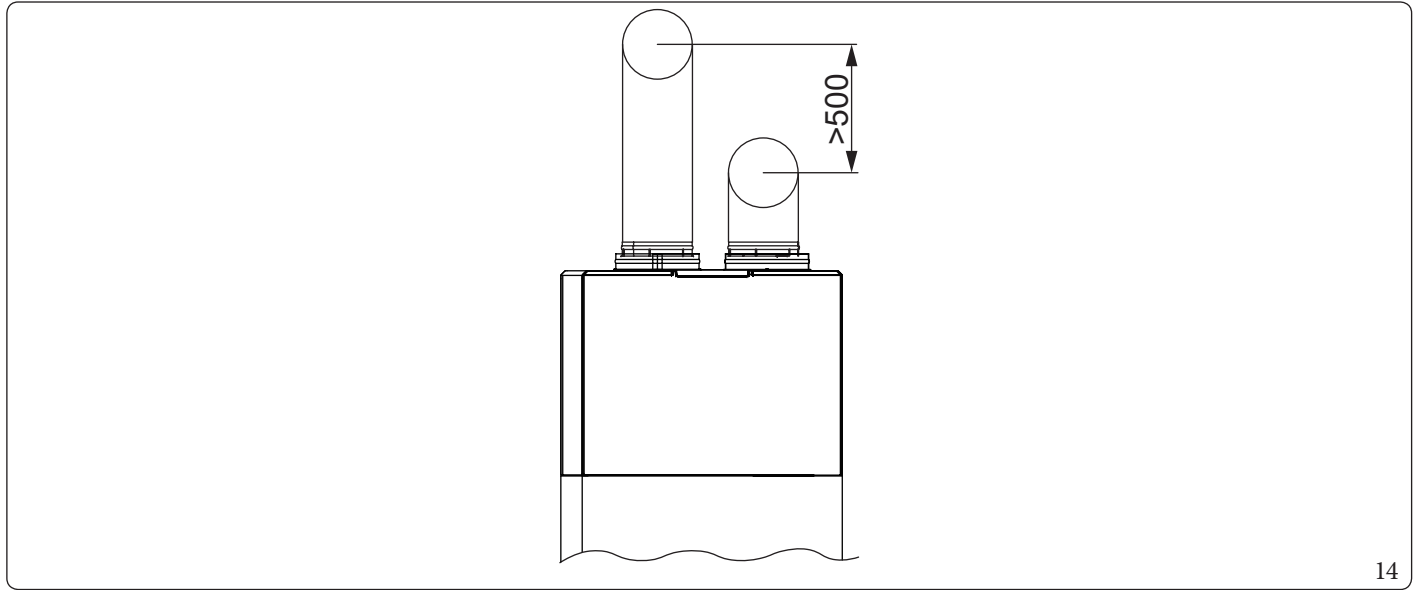

14



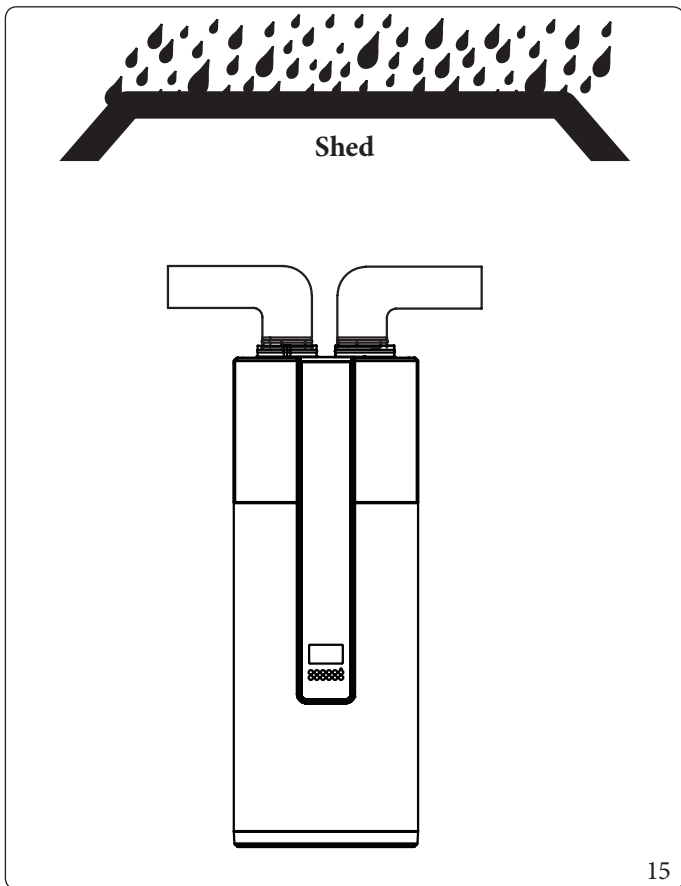

- In the event of rain/water infiltration inside the appliance, the components could be damaged or create dangerous situations for the safety of people (Fig. 15).
- If the appliance is connected to a duct leading to the outside, take all necessary precautions to prevent water from filtering inside the appliance itself (Fig. 15).

INSTALLER

USER

Installing the air intake filter

In the case of a ducted appliance, install the filter (1, Fig. 16) at the entrance to the air intake duct.

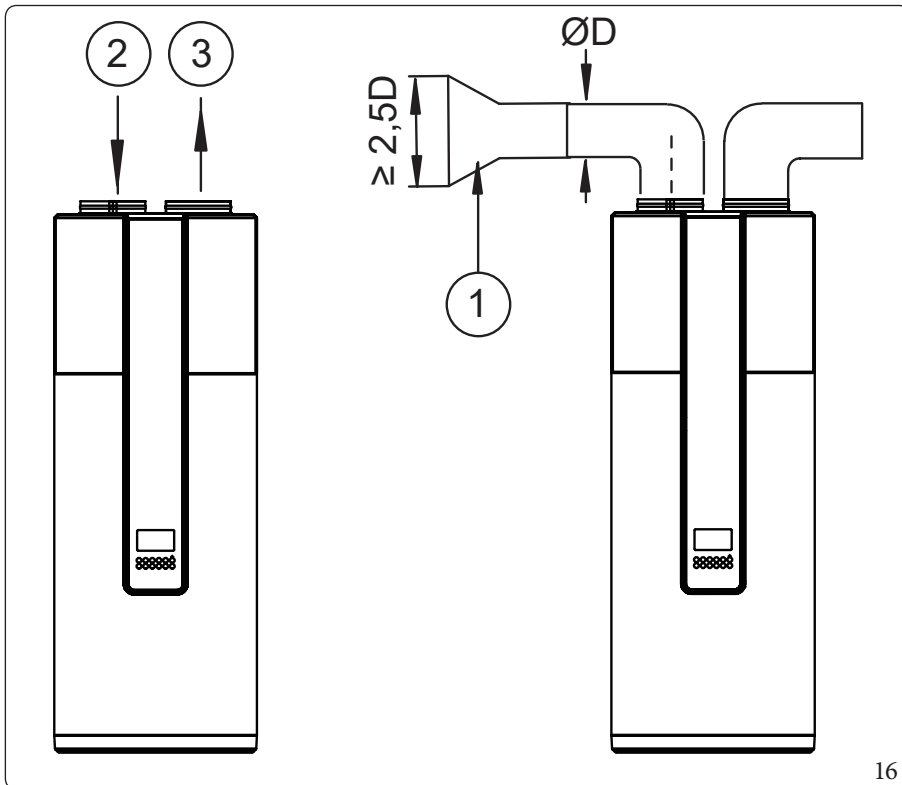

Key (Fig. 16):

- 1 - Filter
- 2 - Air inlet
- 3 - Air outlet

MAINTENANCE TECHNICIAN

TECHNICAL DATA



Filter installation (1, Fig. 16) is the responsibility of the customer; the filter mesh size must be approximately 1.2 mm.



Condensate drain

To allow condensate to drain away easily, install the appliance in a vertical position, otherwise make sure that the condensate drain is at the lowest point. Check that the angle of inclination of the appliance with respect to the ground does not exceed 2°.

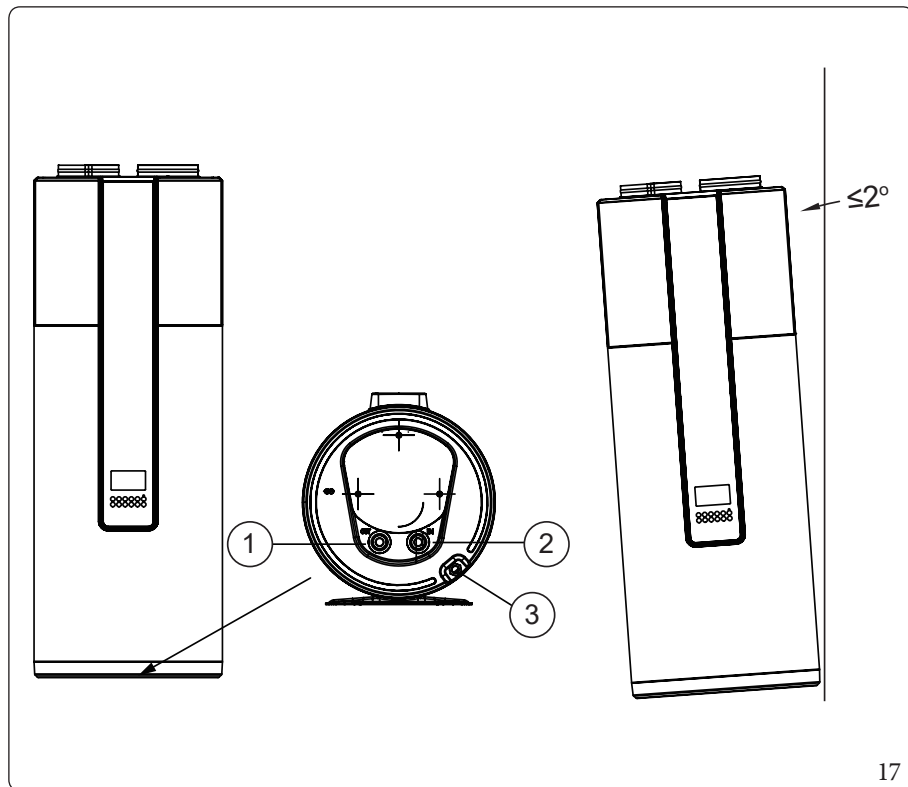

Key (Fig. 17):

- 1 - Domestic hot water outlet
- 2 - Domestic cold water inlet
- 3 - Condensate drainage

1.4.5 Electrical connection



- The appliance is supplied with a power cable with a plug.
- The power supply must come from an independent circuit with nominal voltage as shown in the table below.
- The power supply circuit must be effectively earthed.
- The electrical connection must be carried out by professionally qualified technicians in compliance with national regulations.
- If the appliances are intended to be permanently connected to the fixed electrical installation, it is necessary to install a multi-pole isolator with a pole-to-pole distance of at least 3 mm, a residual current device (RCD) with a rated tripping current not exceeding 30 mA, and an isolating device compliant with wiring regulations.
- The power and signal cables of the connected devices (e.g. Modbus) must be routed correctly and not in contact with the connecting pipe or valve.
- After completing the cable connection, check and ensure that the installation is correct before turning on the appliance.
- Optional components are not included in the standard scope of delivery of the machine. To purchase and install these components, please contact the after-sales service, which will arrange for a qualified technician to intervene.

Power supply specifications

Supply voltage	220-240V~50Hz
Minimum power cable cross-section (mm ²)	≥1,5
Earth cable (mm ²)	≥1,5

Leakage protection

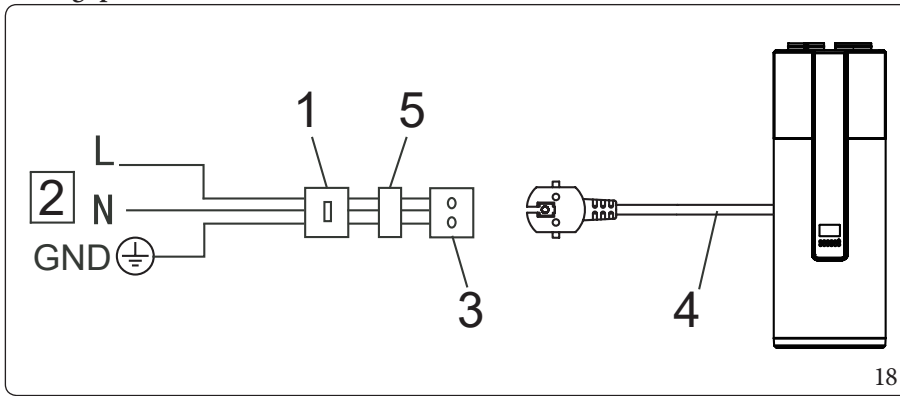

Key (Fig. 18):

- 1 - Residual Current Device (RCD)
- 2 - Power supply
- 3 - Socket
- 4 - Power cable with plug
- 5 - Circuit breaker with omnipolar disconnection



The appliance must be installed using a safety switch on the power supply line and ensuring effective earthing.

INSTALLER

USER

MAINTENANCE TECHNICIAN

TECHNICAL DATA



Wiring diagram

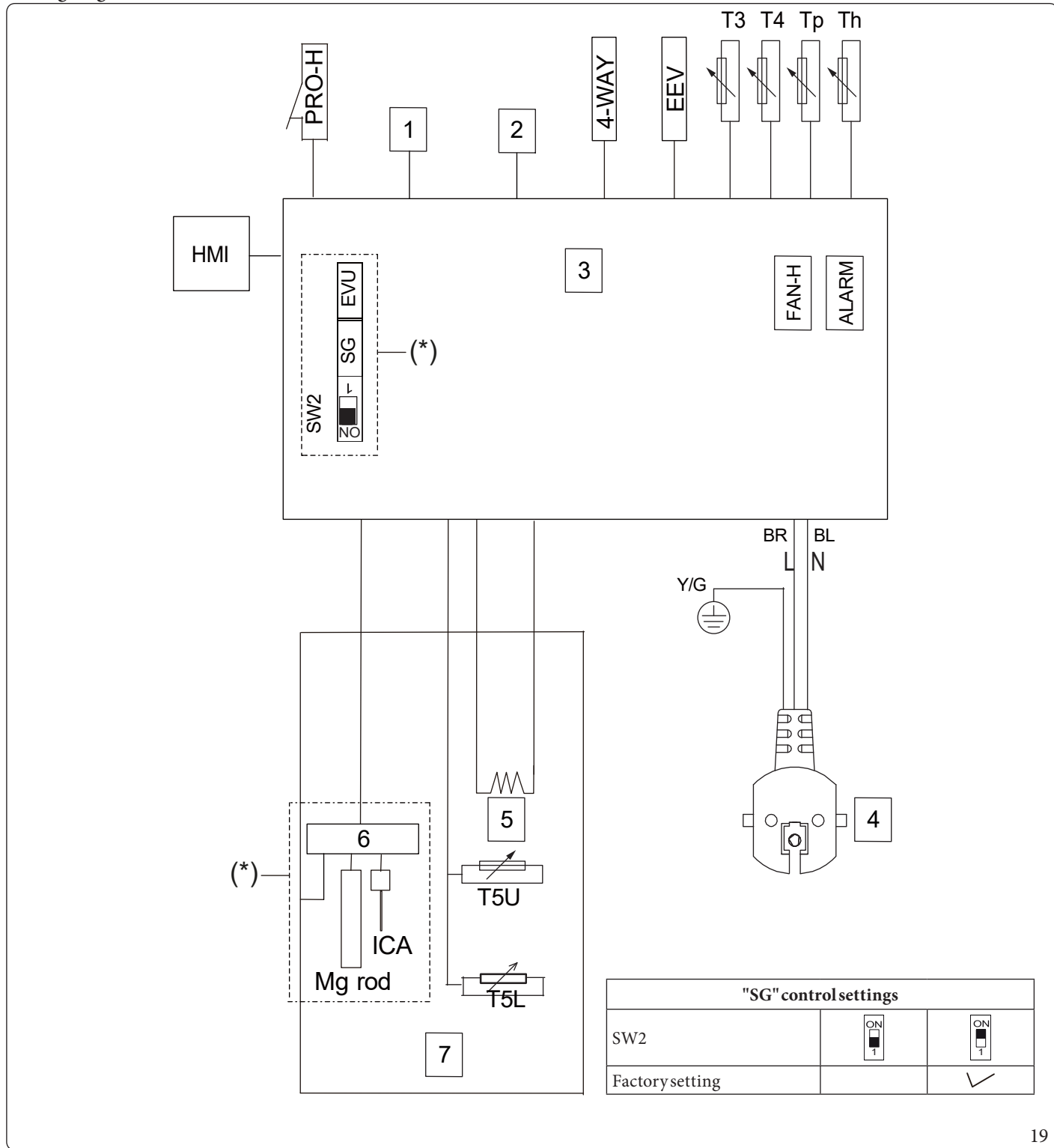

"SG" control settings		
SW2		
Factory setting		✓

Key (Fig. 19):

- 1 - Compressor
- 2 - Fan
- 3 - Main control board
- 4 - Power plug
- 5 - factor
- 6 - Control panel
- 7 - Wiring diagram inside the tank
- PRO-H- High pressure switch
- 4-WAY- 4-way valve
- T3 - Evaporator temperature sensor
- T4 - Ambient temperature sensor
- T5U - Tank temperature sensor (upper)
- T5L - Tank temperature sensor (lower)
- Tp - Drain temperature sensor
- Th - Intake temperature sensor
- EEV - Electronic expansion valve
- XT1 - Central terminal base
- ICA - Electronic anode (not available on this model)
- BR - Brown
- BL - Blue
- Y/G - Yellow/Green



Smartgrid		
Operating behaviour	EVU	SG
Standard operation (default)	Open contact	Closed contact
Increase in operational efficiency	Closed contact	Open contact
	Closed contact	Closed contact
Decrease in operational efficiency	Open contact	Open contact

 For SG and EVU connections, use 3-pole terminal blocks by connecting the cables to the external poles (1-3).

 (*) Optional. The optional element will not be supplied with the appliance. If you have any installation needs, please contact our qualified after-sales service technicians to purchase compliant components and have them installed by qualified technicians.

 The electrical connection coming out of the tank must be connected to the corresponding component.
Set "SW2" to "1" to activate the "SG" port.
The current output (AC) from the motherboard must be controlled through an AC contactor.



1.4.6 Cold water connection

Before connecting, check that the pipe is clean and free of particles resulting from installation. The installation must include a new one-way valve with integrated safety valve and calibrated to 7 bar (0.75 MPa), compliant with EN 1487 and connected directly to the cold water inlet (supplied with the appliance).



No hydraulic device (shut-off valve, pressure reducer, flexible hose, etc.) is permitted between the one-way valve and the cold water inlet of the water heater.

Since water may leak from the safety valve, the drain must be directed to the sewer or outside. In any type of installation there should be a cold water shut-off valve, upstream of the one-way valve.

The water coming out of the safety valve must be connected to the drain via a siphon. Installation must take place in an environment where there is no risk of freezing. The safety valve must be operated periodically to check its operation (1 - 2 times a month).

If the main water pressure is higher than 5 bar (0.5 MPa), consider installing a pressure reducer. This device must be installed at the beginning of the distribution network (before the one-way valve pos. 5, 20). A supply pressure of 3-4 bar (0.3 to 0.4 MPa) is recommended. The appliance must not be connected to more than one water inlet pipe.



- In case of significant fluctuations in system water pressure, it is recommended to install a domestic water expansion vessel (effective volume $\geq 7\%$) to balance the pressure.
- For areas with high limescale content ($Th > 20^\circ f$), water treatment is recommended. After treatment with a softener, the water hardness must not exceed $15^\circ f$. Using a softener does not affect the warranty if the softener is approved for the country of installation and set up in accordance with current regulations, performing regular checks and maintenance.
- Comply with local standards and regulations regarding drinking water quality at the place of installation.

1.4.7 Hot water connection



It is not permitted to connect copper pipes directly to the tank's hydraulic connections. It is necessary to fit an insulating fitting (not included in the supply). If the tank connection is corroded due to the lack of this protection, the appliance warranty will not be valid.



If the installation is made with synthetic pipes (e.g. PER, multilayer...), it is mandatory to install a thermostatic control valve on the water heater connection pipes. The setting must be made in relation to the specifications of the installed piping.

1.4.8 Condensation evacuation



The lowering of the temperature of the air passing through the exchanger causes the formation of condensation from the humidity present in the air itself. The condensed water is evacuated at the rear of the tank through a plastic fitting which must be connected with a pipe (6, Fig. 20) (not included in the supply) to the trap.

Depending on the humidity level in the air, the device can produce up to 0.25 L/h of condensation. The condensate drain line must not be connected directly to the house sewer. Use a siphon containing water to prevent corrosive gases and odours from escaping from the sewer system.

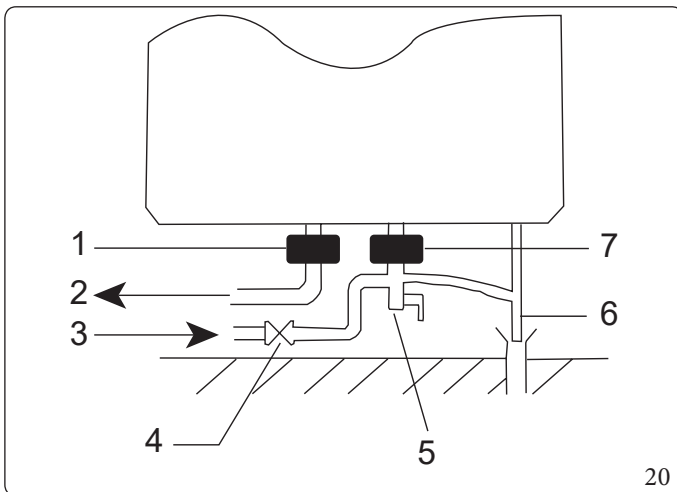

Key (Fig. 20):

- 1 - Insulation
- 2 - Domestic hot water outlet
- 3 - Domestic cold water inlet
- 4 - Shut-off valve
- 5 - One-way valve (included in the supply)
- 6 - Drain pipe
- 7 - Insulation

		Rapax 100 V4
Dimensions of the fittings		
Cold water inlet	mm	DN15
Hot water outlet	mm	DN15
Condensate drain	mm	DN12





Do not block the one-way valve drain pipe.

If the instructions given above are not followed correctly, serious accidents, including personal injury and explosions, may occur.

Installation of the one-way valve with integrated safety valve

- The one-way valve, included in the scope of delivery, has a G1/2" thread. This component blocks the return of water from the tank to the supply network and, at the same time, prevents excessive pressure from building up inside the tank.
- Once the piping installation is complete, open the cold water inlet tap and the hot water outlet tap and let the water flow out of the tank (for example, by opening a tap connected to the system). When the water flows regularly, the tank is considered full. At this point, close all taps and carefully check the pipe connections to ensure there are no leaks.
- If the inlet water pressure is less than 0.15 MPa, a pump must be installed at the water inlet. To ensure safe use of the tank under conditions of water supply pressure exceeding 0.5 MPa, it is necessary to install a pressure reducer on the water inlet pipe.
- If the appliance is installed above a living area, it is mandatory to provide a water collection tray underneath the appliance itself. Connect the tray to a draining system that leads to the sewer.
- Condensation may escape from the appliance if the drain pipe is blocked or if the appliance is used in a particularly humid environment; in this case, it is recommended to use a drain pan, as shown in Fig. 21:

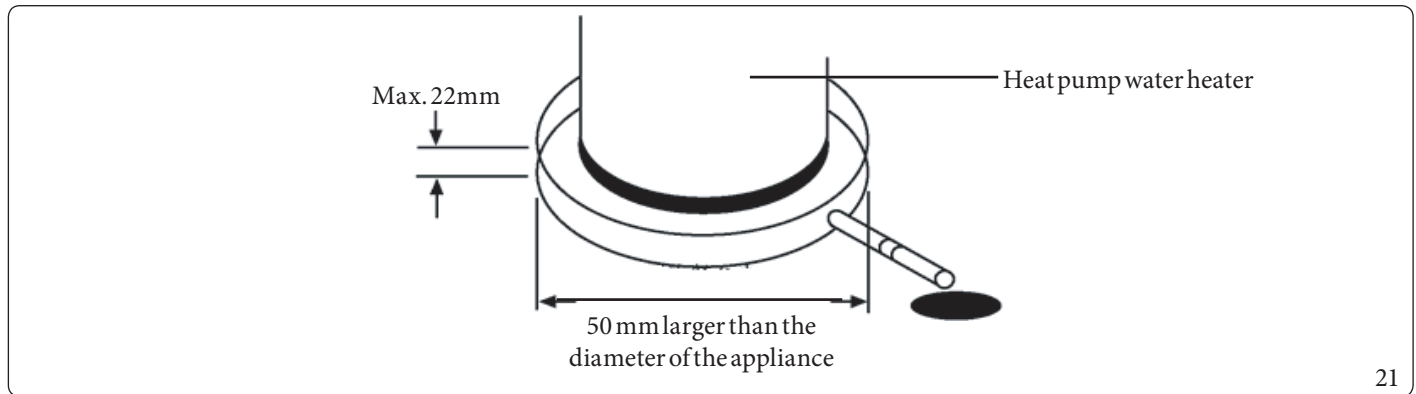

The water heater must be placed in an environment with a volume greater than 15 m³ and where unlimited air circulation is guaranteed. For example, a room measuring 2.5 meters high, 3 meters long and 2 meters wide satisfies this requirement, since its volume is exactly 15m³.

The water inlet (AF) and outlet (UC) pipes have a G1/2" thread. Pipes must be insulated.



The drain pipe must be insulated to prevent the water inside it from freezing in case of temperatures near or below 0°C.



1.4.9 Installation checklist

1. Location and space
 - The wall must be able to support a minimum load of 300 kg.
 - Indoor placement, such as a basement or garage, and in an upright position. Protected from temperatures that may drop below 0°C.
 - Metal drainage pan installed and connected to a suitable drain.
 - Leave sufficient space for maintenance and service.
 - Leave sufficient air for the heat pump to operate. The water heater's heat pump must have unrestricted airflow.
2. Water system pipes
 - The one-way valve is mounted directly on the cold water inlet, without placing any other hydraulic devices between it and the tank.
 - All pipes must be installed correctly and without water leaks.
 - Appliance completely filled with water.
 - It is recommended to install a water temperature mixing valve or mixer.
 - The installation must include a new one-way valve calibrated to 0.75 MPa, compliant with EN 1487 and connected directly to the cold water inlet. No hydraulic device (shut-off valve, pressure reducer, flexible hose, etc.) is permitted between the one-way valve and the cold water inlet of the water heater.
3. Condensate draining line installation
 - Install condensate drain pipes and connect them to a suitable evacuation system or condensate drain pump.
4. Electrical connections
 - For the correct operation of the appliance, a power supply with a voltage between 220-240 VAC is required.
 - Cable specifications and connections must comply with all applicable local regulations and the requirements in this manual.
 - Check that the power supply has been provided with an omnipolar disconnection device that complies with the appliance's requirements and with current local regulations.
 - Check that upstream of the electrical system there is:
 - A 16A omnipolar circuit breaker or fuse with contacts compliant with current local regulations.
 - A single-pole 30 mA disconnect switch.
5. Post-installation overhaul
 - Make sure users understand how to use the "Control panel" to set different modes and access various functions.
 - Ensure users understand the importance of periodic inspection/maintenance of the condensate collection tray and drain pipes. All this helps prevent possible blockages in the drain pipes that cause the condensate drain pan to leak.
 - If you notice water leaking from the plastic casing of the appliance, this indicates that both condensate drain lines may be blocked.
 - To maintain optimum performance, check, remove and clean the air filter.



1.5 FINAL INSPECTIONS AND TEST OPERATION

1.5.1 Filling the tank with water before operation

Before using the appliance, follow these steps:

1. Filling with water

If the appliance is used for the first time or reused after emptying the tank, make sure the tank is full of water before switching it on (Fig. 22).

- Close the cold water inlet tap and open the domestic hot water tap, if any (pos. A, Fig. 22).
- When water flows continuously from the hot water tap, the tank is considered full. Close the domestic hot water tap. The filling operation is now complete (pos. A, Fig. 22).

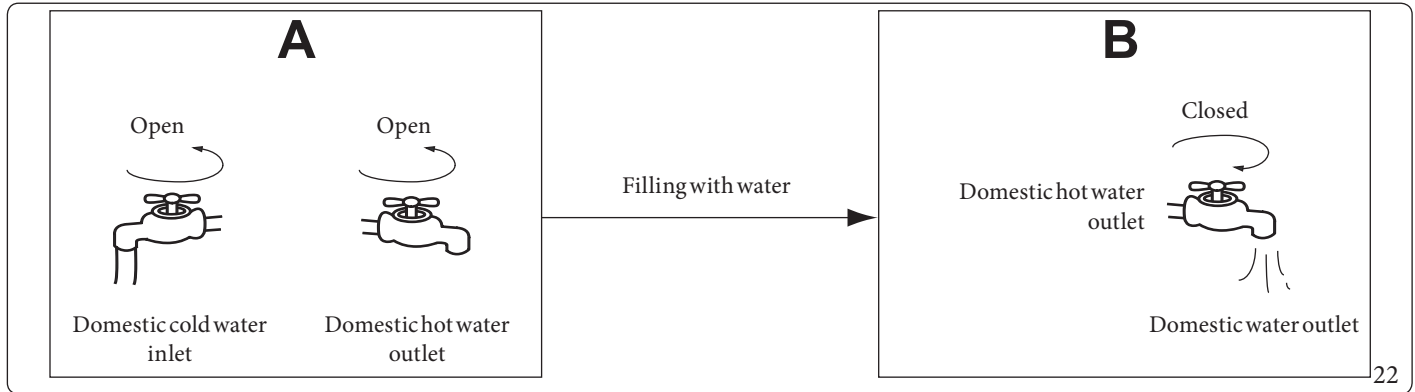

Operating without water in the tank can lead to damage to the electric heater. The manufacturer declines all responsibility for any damage caused by failure to follow the procedure.

2. Draining

If it is necessary to clean the appliance, move it or stop using it, carry out the following procedures (Fig. 23):

- Close the cold water inlet tap, open the domestic hot water tap and open the draining tap (C, Fig. 23).
- After emptying, close the drain tap (D, Fig. 23).

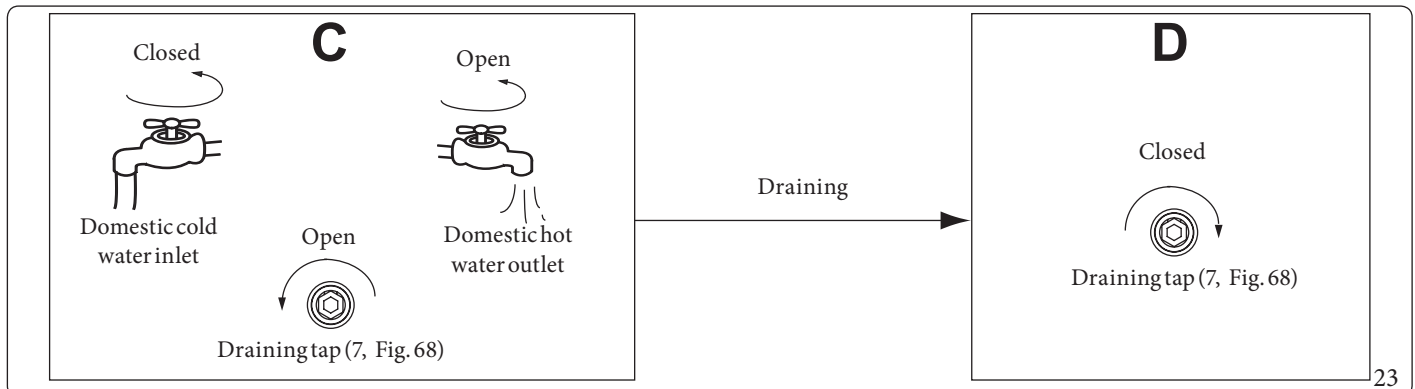

1.5.2 Operation checks

Checklist of checks to be carried out before putting the machine into service.

- Correct installation of the system.
- Correct connection of water/air pipes and electric power supply.
- Condensate drainage and correct installation of all hydraulic components.
- Correct power supply.
- No air in the water pipe and all valves open.
- Effective installation of electrical protections.
- Correct inlet water pressure (between 0.15 MPa and 0.7 MPa).
- Make sure the tank is full of water before turning the appliance on (see par. 1.5.1).

1.5.3 Information on operation

System structure diagram

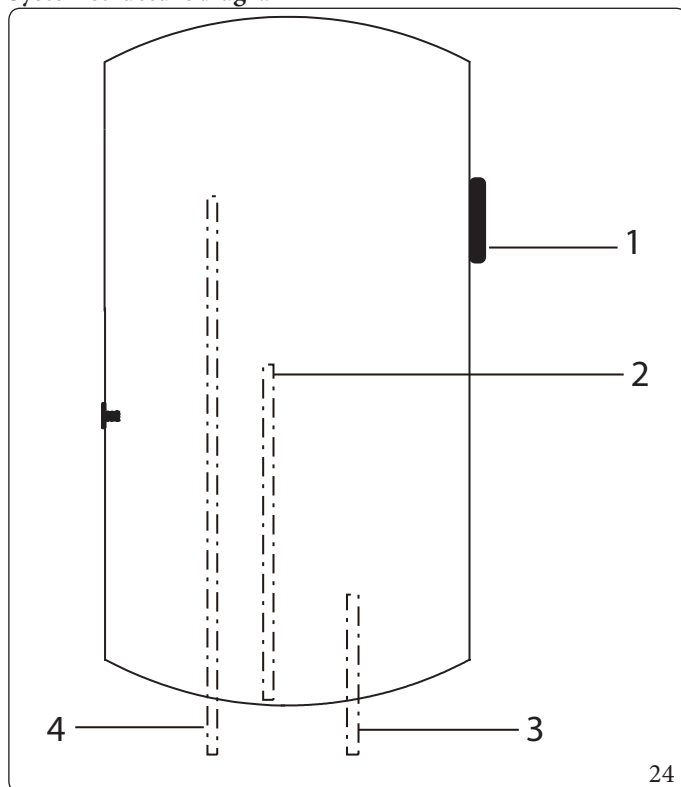

Key (Fig. 24):

- 1 - Temperature sensor (T5U)
- 2 - Temperature sensor (T5L)
- 3 - Domestic cold water inlet
- 4 - Domestic hot water outlet

System information

- The appliance has two types of heating sources: heat pump (compressor) and electric heater. The appliance will automatically use the optimal heating sources to heat the water to the required temperature.
- The modes will be automatically selected by the appliance. Manual selection is not available.

Operating temperature range

- The temperature shown on the display is the maximum temperature recorded by the upper sensor (T5U) and the lower sensor (T5L) (Fig. 24).

User-adjustable temperature range for hot water		38÷65°C
Minimum installation room temperature		0°C
Maximum installation room temperature		43°C
Minimum inlet air temperature (a)	Heat pump	-7°C
	Electric heater	-20°C
Maximum inlet air temperature (a)	Heat pump	43°C
	Electric heater	45°C

(a) Temperature range of air entering through the air duct from outside (for models with air inlet duct).

Water temperature limits

Ambient inlet air temperature (T4)	T4<-7	-7≤T4<-2	-2≤T4<2	2≤T4<35	35≤T4<43	43<T4
Maximum temperature (Heat pump)	--	45	55	65	60	--
Maximum temperature (Electric heater)	70°C (Maximum outlet temperature is set to 65 °C as factory default)					

Changing the heating source

- The default heating source is the heat pump.
- If the inlet air temperature is outside the heat pump's operating range, it will stop operating and automatically activate the electric heater to continue heating the water up to the set value. When the inlet air temperature returns within the heat pump's operating range, the electric heater will deactivate and the appliance will automatically return to heat pump operation.
- If the set water temperature exceeds the maximum value that the heat pump can reach (taking into account the current inlet air temperature), the appliance will initially activate the heat pump. This will operate until it reaches its maximum operating temperature and then the appliance will activate the electric heater to continue heating the water continuously until the user's desired temperature is reached.



- Press the button (H, Fig. 28), the electric heater will be activated for the current heating cycle. If you want to reactivate it, press the relevant button again.
- If the electric heater is manually activated while the heat pump is running, the electric heater and the heat pump will operate together until the set water temperature is reached. This procedure is useful if you need to heat the water quickly.

Defrosting during water heating

If the evaporator freezes during heat pump operation due to low inlet air temperature, the system will automatically perform a defrost cycle to maintain effective performance (this process will take approximately 3-10 minutes). When defrosting, the fan motor will stop, but the compressor will continue to run.



Heating time.

Heating times vary depending on the ambient temperature. Typically, a lower temperature results in longer heating times due to the lower efficiency of the appliance. The indicative values for the water heating time (from 15 to 55°C) in "ECO" mode are shown in the graph in Fig. 25.

A difference in heating times may occur due to different installation methods of the appliance.

When the air temperature is below 2°C, the heat pump and the electric heater will absorb different percentages of heating capacity.

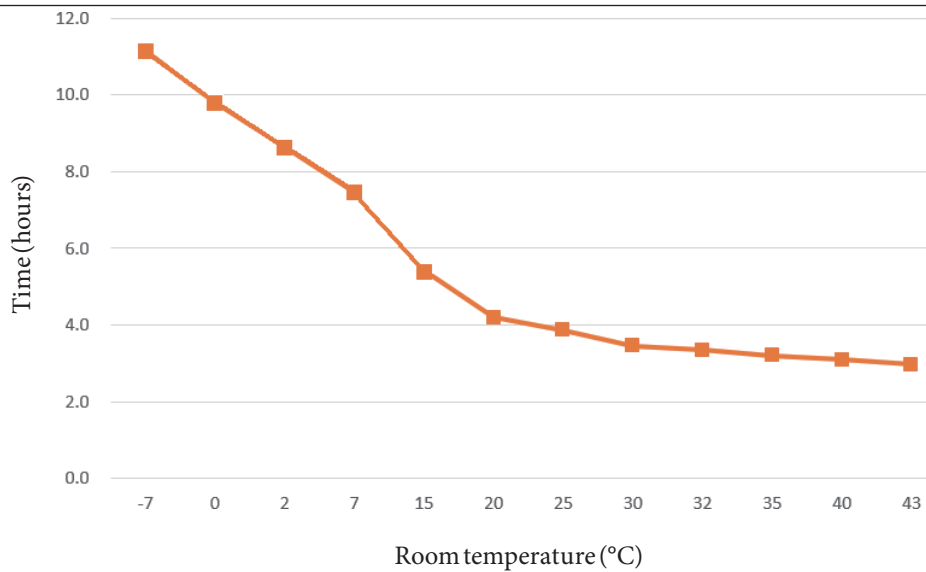

25

Information about the "TCO" thermal switch

The power supply to the compressor and the electric heater will be automatically interrupted or activated by the "TCO". If the water temperature is above 85°C, the "TCO" will automatically cut off the power to the compressor and the electric heater.



Disconnect the power supply before manually resetting the TCO using the relevant button and then reactivate it.

Restart after a long interruption

If the appliance is restarted after a long period of inactivity, the outlet water may appear dirty. In this case, simply open the water tap and let it run to clean the system.



2 INSTRUCTIONS FOR USE AND MAINTENANCE

2.1 GENERAL RECOMMENDATIONS



This appliance is not intended for use by persons (including children) with reduced physical, sensory or mental capabilities, or lack of experience and knowledge, unless they have been supervised or instructed in the use of the appliance by a person responsible for their safety.

Children must be supervised to ensure that they do not play with the appliance.



Battery performance

To ensure longer battery life, it is recommended not to disconnect the power supply if the device is not used for a long time.

2.2 CONTROL PANEL

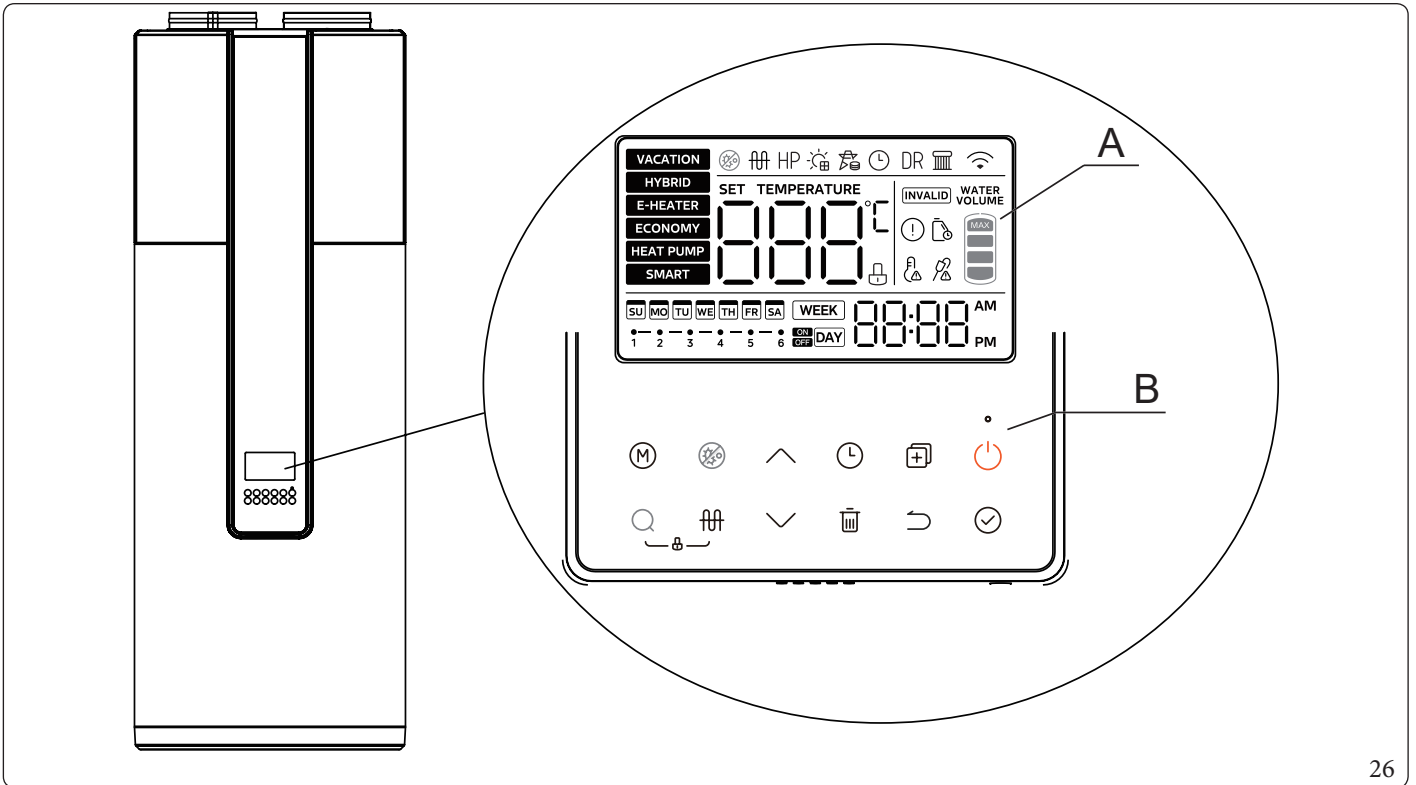

Key (Fig. 26):

- A - Display
- B - Control buttons

INSTALLER

USER

MAINTENANCE TECHNICIAN

TECHNICAL DATA







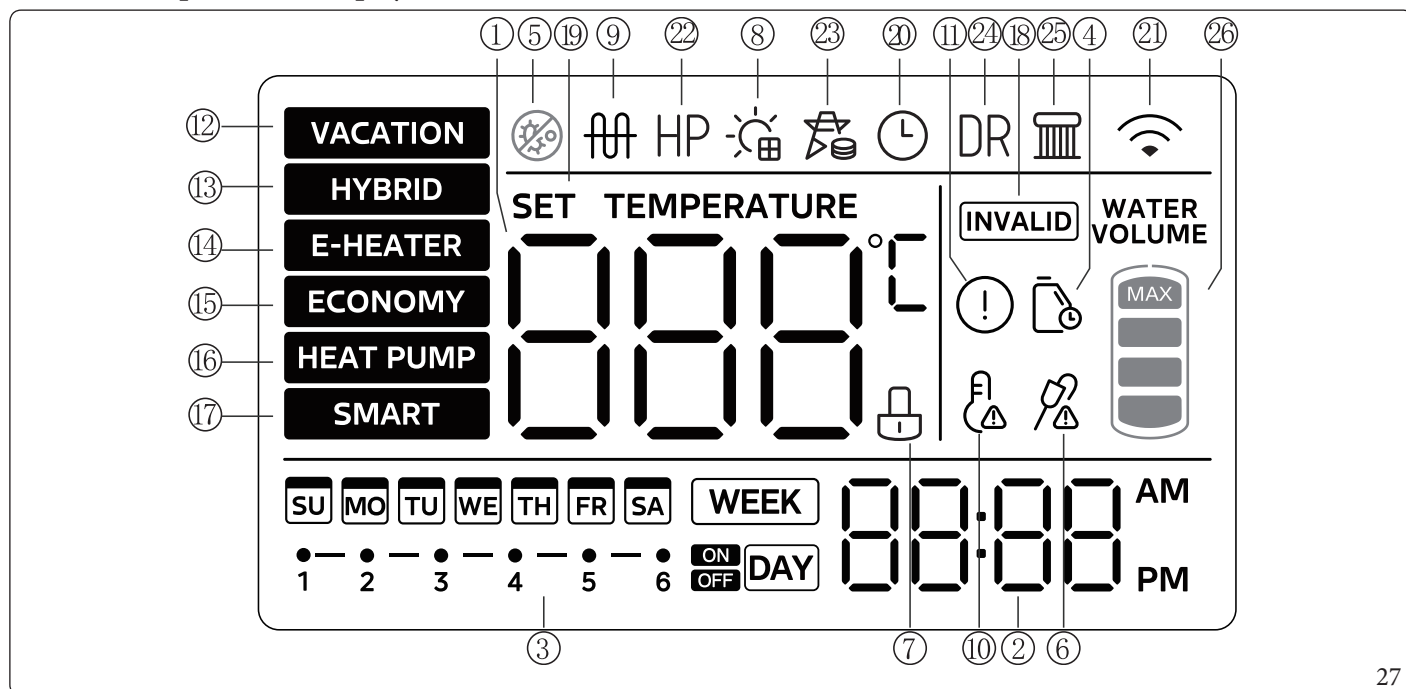









26



2.2.1 Description of the display



No	Icon	Description
1		When the screen is unlocked, the icon is illuminated and shows the following information: - current water temperature; - the remaining vacation days (holiday mode active); - the temperature you are setting; - the appliance settings or parameters, error codes and information on any protections that have intervened.
2		Time and clock setting: displays the current time. Each time the clock is set, the icon lights up.
3		There is an option to set a schedule on a weekly or daily basis. If no schedule is set, the corresponding part of the screen remains blank. Otherwise, the corresponding icon is displayed accordingly. During set-up, the icon selected for configuration starts flashing.
4		The icon flashes to remind the user when the next water tank maintenance is due.
5		The icon lights up when the disinfection process is active.
6		Warning about electronic anode (not available on this model).
7		Block: if the buttons are locked, the icon will be on, otherwise it will be off.
8		EVU (optional): When the solar panel is detected to be working, the icon lights up; the temperature is adjusted to the highest value and the appliance quickly produces hot water.
9		Electric heater: the icon lights up when the electric heater is on. NOTE: When the operating conditions requiring the activation of the electric heater are not met, the corresponding icon is displayed briefly and then goes out.

No	Icon	Description
10		High temperature alarm: The icon lights up when the water temperature exceeds 50°C and goes out when the temperature drops.
11		Error: the icon lights up when the appliance is in an error/protection condition.
12		Holiday mode: for holiday mode, the water temperature will be set to 15°C to maintain low energy consumption by preventing freezing in the tank.
13		Hybrid mode: The electric heater and the heat pump work simultaneously in two specific circumstances: - when environmental conditions are at extremely low temperatures; - when the heat pump has been running for a long time and is unable to reach the set temperature on its own.
14		E-HEATER mode (electric heater): in case of heating demand, the heat pump and the electric heater will operate simultaneously provided that all the operating conditions required by the heat pump are met.
15		Energy saving mode (economy): depending on the inlet air temperature, the appliance (in heat pump mode) heats the water up to the maximum temperature achievable (before the electric heater activates). The heat pump and electric heater will not operate simultaneously. We recommend using this mode, as it allows for greater energy savings.
16		Heat pump mode: the icon lights up when the machine is operating in heat pump mode.
17		Smart mode: smart mode records the user's hot water consumption habits (considering the last 7 days). Based on these habits, the appliance heats the water in advance. During other periods, the appliance remains in standby and the water is not heated. It is recommended that the user set this mode only after 7 days of normal operation of the appliance. This feature ensures that the appliance records your complete habits and does not negatively impact your hot water usage.
18		When a button that is not consistent with the adjustments being made is pressed, this icon flashes for 3 seconds.
19		The icon lights up when the water temperature is set.
20		The icon lights up when the time is set in the system.
21		Wireless: The icon lights up when the wireless network is connected; it is off when the wireless network is not connected; it flashes at a frequency of 2 Hz during wireless network set-up.
22		Heat pump: the icon lights up when the heat pump (compressor) is running and producing hot water.
23		Smart Network (optional): When the SG signal has an open contact, this icon does not light up and the machine does not turn on normally.
24		Not used
25		Not used
26		Not used

INSTALLER

USER

MAINTENANCE TECHNICIAN

TECHNICAL DATA



2.2.2 Description of control buttons



Pressing the button is effective only when the display is unlocked.

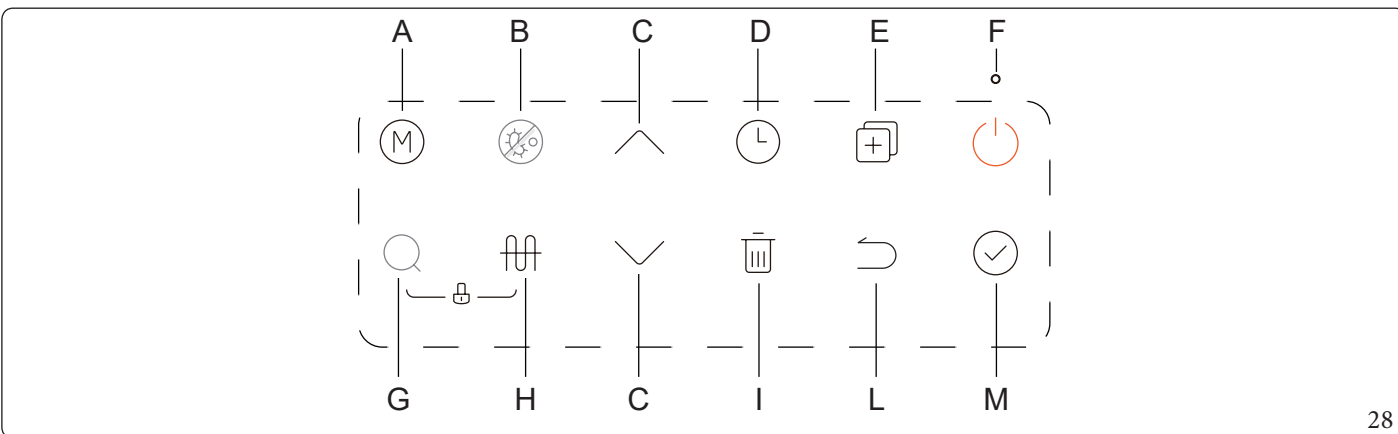

28

No	Icon	Description
A		<p>Changing mode Press this button to select the various operating modes: Default hybrid mode (HYBRID) -> Electric heater mode (E-HEATER) -> Energy saving mode (ECONOMY) -> Holiday mode (VACATION). For holiday mode, adjust the days from 1 to 360.</p>
B		<p>Disinfection function This button allows you to force the activation of the disinfection function. By pressing the button, the icon will light up and the appliance will activate the function; the water will be heated to a temperature of 65°C until the disinfection is complete. At the end of the cycle, press the button again to end the disinfection procedure.</p>
C		<p>Increase and Decrease of values If the display is unlocked, press the buttons to adjust the displayed values. When setting the temperature/timer/vacation days, press and hold the buttons for more than 1 second to continuously change the value. Press the button (M) to confirm the selected setting. Also use the buttons to scroll through the various items you want to check/view.</p>
D		<p>Daily setting - Press the TIMER button (D) to display the daily timer icon and access the function by pressing the button (M). The daily timer has a total of 6 configurable time slots; each slot can be set to start/stop the selected mode and adjust the water temperature. Once you have configured the first slot, press the confirmation button (M) to move on to the next slot. Once you have set the sixth slot, press the confirmation button (M) to return to the main screen. - When setting the on and off time, press the (I) button to reset to the default value. - If there is a conflict between the time slots you set, the second configured slot will be considered valid; the invalid slot will be reverted to the default setting. - Daily timer setting can be accessed both when the machine is started and when it is shut down.</p> <p>Weekly setting - Press the TIMER button (D) to display the weekly timer icon and access the function by pressing the button (M). The weekly timer has a total of 7 configurable days, with 6 time slots that can be set daily. Each slot can start/stop the set mode and change the water temperature. Once you have configured the first slot, press the confirmation button (M) to move on to the next interval settings. Once you have set the sixth time slot, press the confirmation button (M) to return to the main screen. - When setting the on and off time, press the (I) button to reset to the default value. - If you adjust the time again after completing the setting, all settings after the changed time slot will be cleared. For example, if you adjust the settings for time slot 2, the settings for time slots 3, 4, 5, and 6 will all be cleared. The mode and water temperature will return to the default values (energy saving mode, 60°C). - When setting the weekly timer, use the button (E) to copy the settings of an already configured day; subsequently select other days by pressing the button (E) again (the status LED will flash quickly). Press the button (M) to confirm the operation and copy the settings to the selected days. - Weekly timer setting can be accessed both when the machine is started and when it is shut down.</p>



No	Icon	Description
E		<p>Configuration mode</p> <p>On the main screen, press and hold the button (E) for 3 seconds to enter the "configuration mode"; use the buttons (C) to select the inspection parameter and view the value assigned to the parameter itself. Use the buttons (C) to change the parameters and confirm any changes using the button (M) to make them effective. To exit the "configuration mode" wait 30 seconds after the last operation or press the buttons (F or L). The "configuration mode" can be activated both during the start-up and shut-down phases of the machine.</p> <p>To avoid compromising the normal operation of the appliance or damaging it, the customer is strictly prohibited from changing the parameter settings without the manufacturer's authorisation.</p> <p>The default maximum temperature is 65°C; if you need to use a higher temperature, enter the configuration mode by selecting "parameter 18" and increase the temperature limit to 70°C.</p>
F		<p>On/Off button</p> <p>Press the button to turn the device on or off.</p>
G		<p>Control and search function</p> <ul style="list-style-type: none"> - On the main screen, press and hold the button (G) for 1 second to enter search mode. Use the buttons (C) to change the quick control parameter; the value assigned to the selected parameter will be displayed. - To exit search mode, wait 30 seconds after the last operation or press the buttons (F or I). - Search mode can be accessed both when the machine is started and when it is shut down.
H		Press this button to manually activate the electric heater operation.
I		<p>Delete</p> <p>This button is used to cancel all current settings and exit the set-up mode. When the wireless connection is working, press and hold the button (I) for more than 8 seconds to disconnect the connection.</p>
L		<p>Back</p> <p>Press the button to return to the previous setting or main screen.</p>
M		<p>Confirm</p> <p>After setting any parameter, you need to press the appropriate button to load and save those parameters into the appliance.</p>

Button combination

No	Icon	Description
Setting the date and clock		<ul style="list-style-type: none"> - From the main screen, hold down button (D) for 3 seconds to access the date setting; press buttons (C) to select the desired date and confirm the change using button (M). Then press the buttons (C) to change the time. Confirm the change by pressing the button (M). - To exit the menu, wait 30 seconds after the last operation or press the buttons (F or L). - These changes can be made both at start-up and shutdown.
Connecting to the wireless network	 Press for 3 seconds	<p>Connecting to the wireless network</p> <ul style="list-style-type: none"> - On the main screen, press and hold the button (M) for 3 seconds to enter wireless network mode; the icon will light up in the upper right corner of the display. Access the application (see Par. 2.5), select the heat pump water heater category, select the correct appliance model and connect to the network according to the application's requests. Once the connection is established, the wireless icon will remain lit. - Wireless pairing can take up to 8 minutes; if pairing fails after 8 minutes, the wireless icon will turn off. - Press the button (I) for 8 seconds to reset the wireless function; this operation can be performed both when switching on and off.
Child safety lock	 Press for 2 seconds	<p>Child safety lock</p> <ul style="list-style-type: none"> - On the main screen, press and hold the button combination (G+H) for 2 second to activate the child lock status. - To unlock the display, hold down the 2 buttons for at least 2 seconds. - In the lockout status, the icon lights up next to the water temperature display.



2.3 OPERATING MODE

Basic operation

Press the button (F, Fig. 28) to turn on the appliance; use the buttons (C, Fig. 28) to set the water temperature (38-65 °C) and validate the data by pressing the button (M, Fig. 28). The appliance will automatically select the heating sources to be used to heat the water to the desired temperature.

Weekly disinfect function

In disinfection mode, the appliance starts heating the water up to 65°C to eliminate any potential bacteria that may be present in the water in the tank. The icon (B, Fig. 28) will light up on the display while disinfection mode is operating. The appliance will stop disinfecting if the water temperature rises above 65°C.

Holiday function

Press the button (A, Fig. 28) to select "holiday mode"; the appliance will automatically maintain the water temperature at 15°C in order to save energy during days of non-use.

Remote shut-down function

Users have the option to connect an external switch to the appliance. If the switch is turned off, the appliance will be forcibly shut down. If the switch breaks or malfunctions, the appliance can operate normally according to the default settings.

Automatic restart

In the event of a power failure or interruption, the appliance is able to store all the parameters and settings that have been configured by the user. When power is restored (when the power comes back on), the appliance automatically resumes operation using the settings that were active before the interruption.

Automatic button lock

The device is equipped with an automatic button lock function. If no buttons are pressed for 60 seconds, the buttons lock to prevent accidental modifications. To unlock the display, you need to press the buttons G+H simultaneously (Fig. 28).

Automatic screen backlight switch-off

If no button operations are performed for a period of 60 seconds, the screen automatically locks and turns off. Only in the event of a malfunction will the alarm icon and the related error code remain visible on the screen to warn the user.

To unlock and turn the screen back on, press any button.

To enable or disable this automatic lock feature, you need to enter the "configuration mode" and select "parameter 35".



It is recommended that you connect to the wireless network before using the daily timer, weekly timer, weekly disinfection, holiday mode and smart mode functions. If there is no network connection, ensure that the correct time is set on the control panel before using these functions. If there is no network connection, reset the correct time on the panel after the unit has been switched off for a long period.

Automatic protection

When the automatic protection function is activated, the system shuts down and starts a self-diagnostic function; once the problem is resolved, the appliance begins a lengthy system reboot.

When automatic protection is activated, the icon (11, Fig. 27) flashes and the corresponding error code is displayed on the water temperature indicator. The error code and symbol will remain visible until the automatic protection function is completed.

Automatic protection can be activated in the following cases:

- the air inlet or outlet is blocked.
- the evaporator is covered with too much dust;
- incorrect power supply (above the range of 220-240 V).



Search mode

Press and hold the button (G, Fig. 28) for at least 1 second to enter search mode; scroll through the values using the buttons (C, Fig. 28) and to view the parameters shown in the following table.

NO.	Parameter	Unit	Description
1	T5U	Temp.	T5U
2	T5L	Temp.	T5L
3	T51	Temp.	--
4	TS	Temp.	Heat pump stop temperature
5	T3	Temp.	T3
6	T4	Temp.	T4
7	TP	Temp.	TP
8	TH	Temp.	Th
9	On		--
10	TFr		--
11	TT	Temp.	Disinfection temperature
12	CO	Current	Compressor and electric heating current
13	FO	Fan	ACFan 0: OFF 1: Low 2: MID DcFan Realspeed/10
14	EO	Machine parameters	0~255
15	EEr		Electric heater control type
16	EEC		Compressor and electric heating current
17	PUP		--

NO.	Parameter	Unit	Description
18	P5		--
19	FT		0: ACFan 1: DCFan
20	HT		1 (Electric heater control type)
21	HP		0 (Compressor control type)
22	FS1		--
23	S1O		Tank capacity
24	P4P		Four-way valve status
25	UU		0
26	U1	Version	Host software version
27	U2	Version	LCD panel software version
28	U3	Version	0
29	U4		0: An electric heater 1: Two electric heaters
30	UT		3
31	1Er		Last error code
32	2Er		Previous error or protection code 1
33	3Er		Previous error or protection code 2
34	HHH		Maintenance time
35	TLF		Desired temperature
36	End		End sign

INSTALLER

USER

MAINTENANCE TECHNICIAN

TECHNICAL DATA



2.4 APPLIANCE CONFIGURATION WITH THE SMARTPHONE APP

2.5.1 Download and install the App



The following QR codes are provided to download our APP called “CLIMAsmart”.

Android users.

Scan the dedicated QR code or go to Google Play, search for the “CLIMAsmart” app and download it.



29

iOS users.

Scan the dedicated QR code or go to the App Store, search for the “CLIMAsmart” app and download it.



30

2.5.2 User registration

Make sure your mobile device is connected to your wireless router and the router is already connected to the Internet before performing user registration.

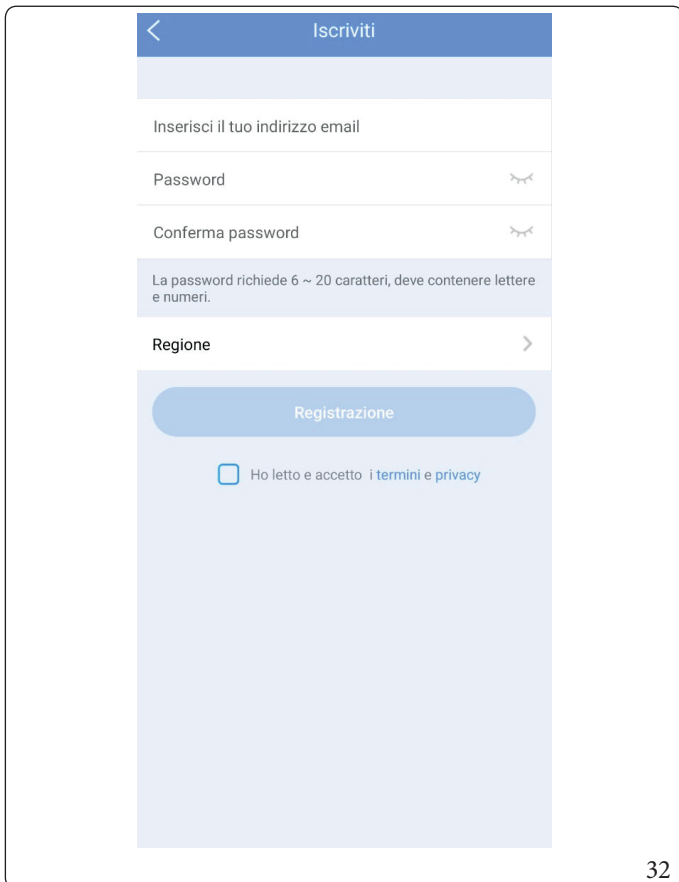
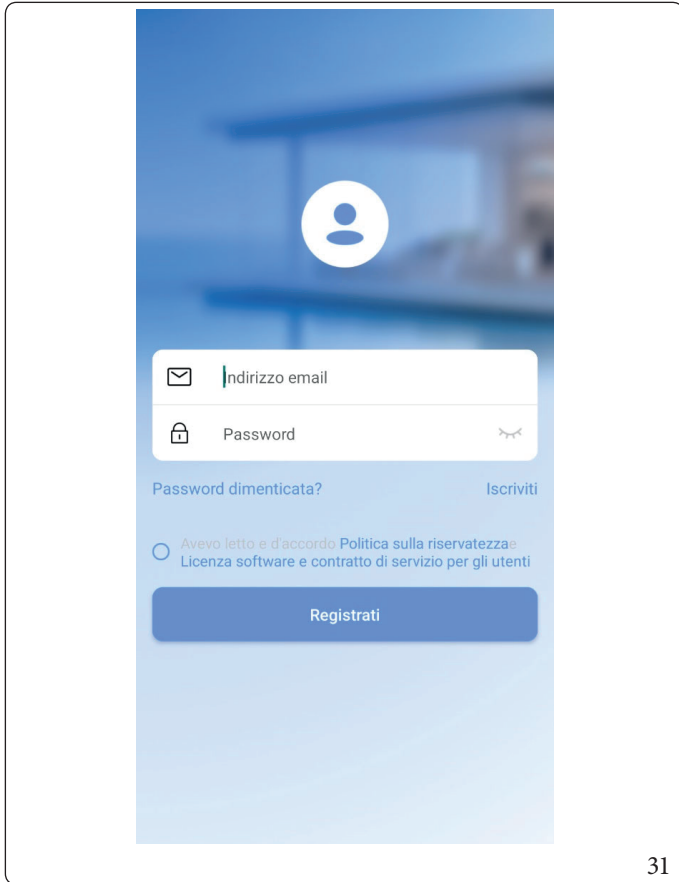

1. Click on "Subscribe"

2. Enter your email address and password, followed by your region, then click on "Register". To proceed, you must accept the terms of use and authorise the processing of personal data.



2.5.3 Preparing for network configuration

- You need to disconnect from any other nearby networks and make sure your Android or iOS device connects to the Wireless network you want to set up.
- Make sure that the wireless function of your Android or iOS device is working properly and can automatically reconnect to the original wireless network.

Use an Android or iOS device for network configuration.

1. Make sure your mobile device has already been connected to the Wireless network you want to use.
2. Make sure the appliance is properly powered.

2.5.4 Network configuration (automatic method)

Press and hold the "Stand-by" button on the product control panel (F, Fig.) for 3 seconds. 28).

The flashing wireless connection symbol will light up in the top right corner of the display.

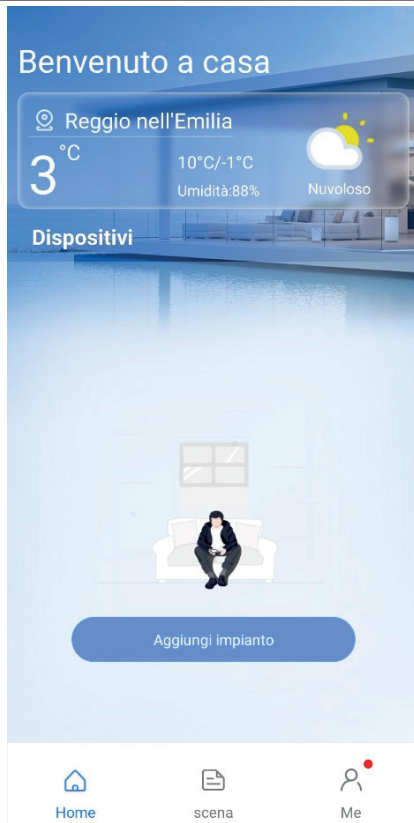

1. Press "Add system".

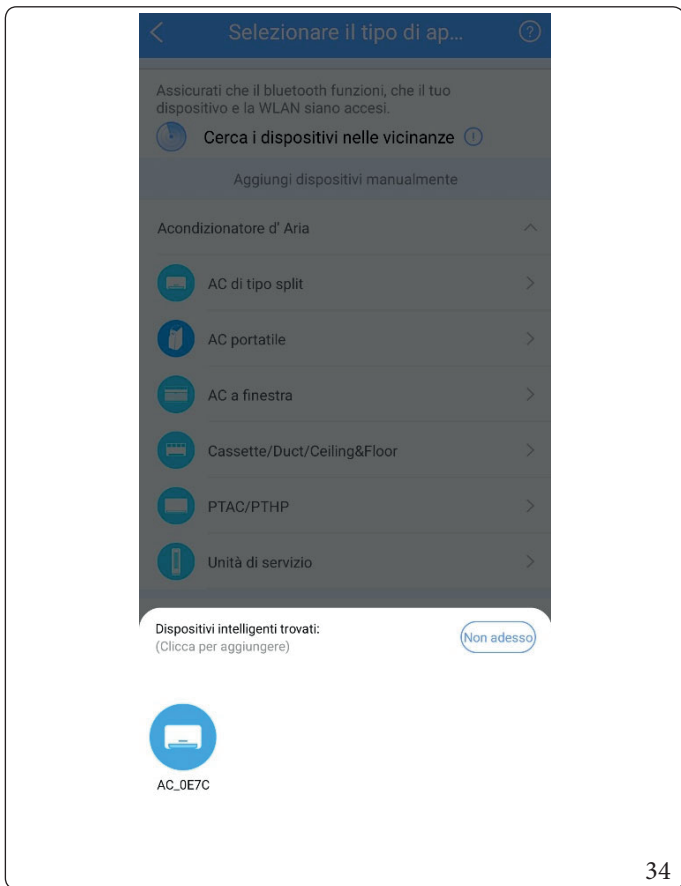

34

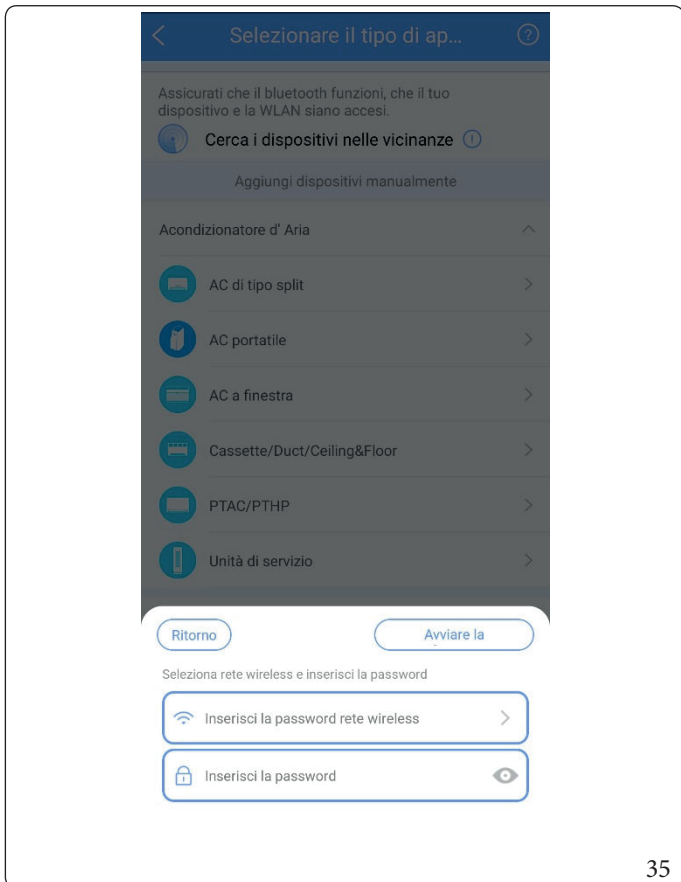

35

2. Wait for the device to be searched, then select it to add it.

3. Select the name of the wireless network to which you want to connect the appliance and enter the password.



The appliance supports 2.4 GHz Wi-Fi wireless networks only.

INSTALLER

USER

MAINTENANCE/TECHNICIAN

TECHNICAL DATA



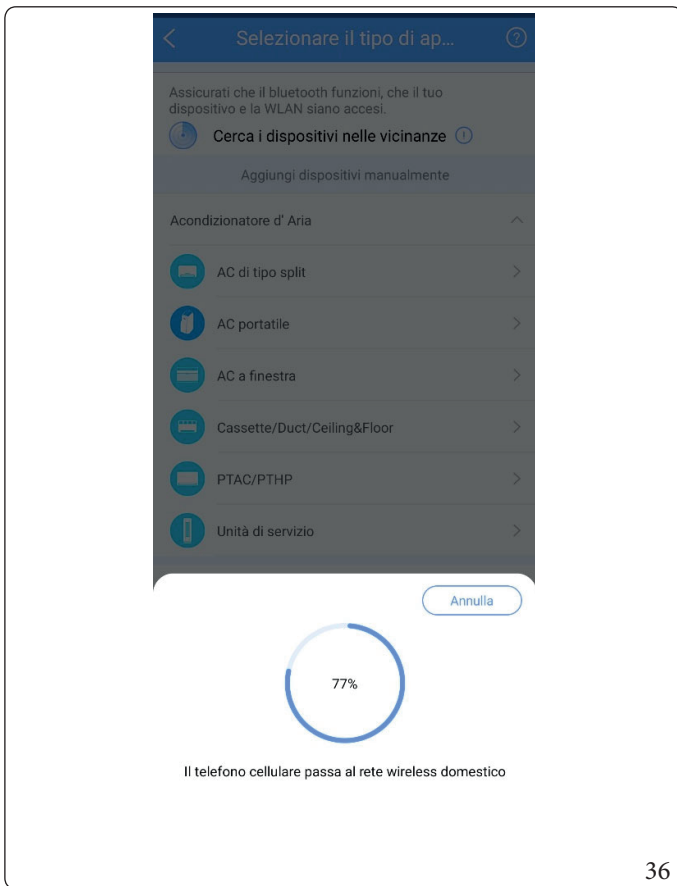

36

4. Wait for the network connection.

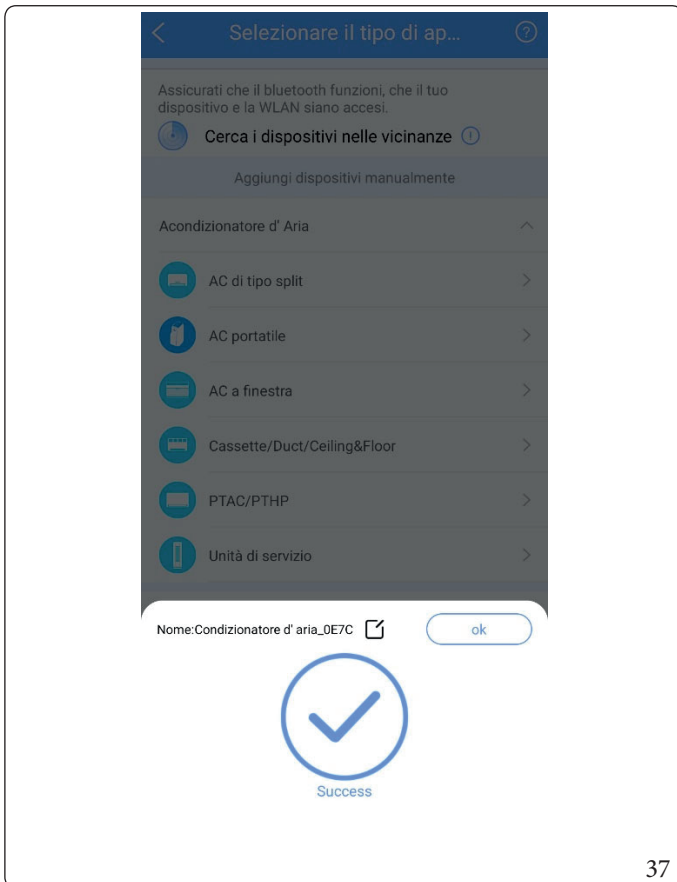

37

5. Configuration successful. You can now change the default name.

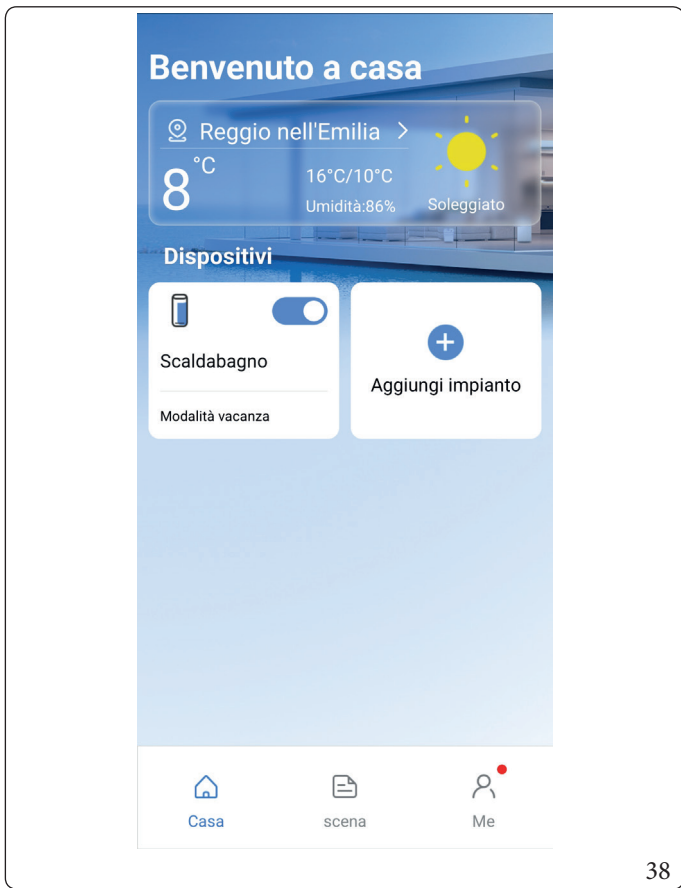

38

6. Device set-up was successful, you can now see the device on the home screen.

INSTALLER

USER

MAINTENANCE/TECHNICIAN

TECHNICAL DATA



2.5.5 Network configuration (manual method)

If the automatic configuration, seen in the previous paragraph, fails, follow the manual configuration below.

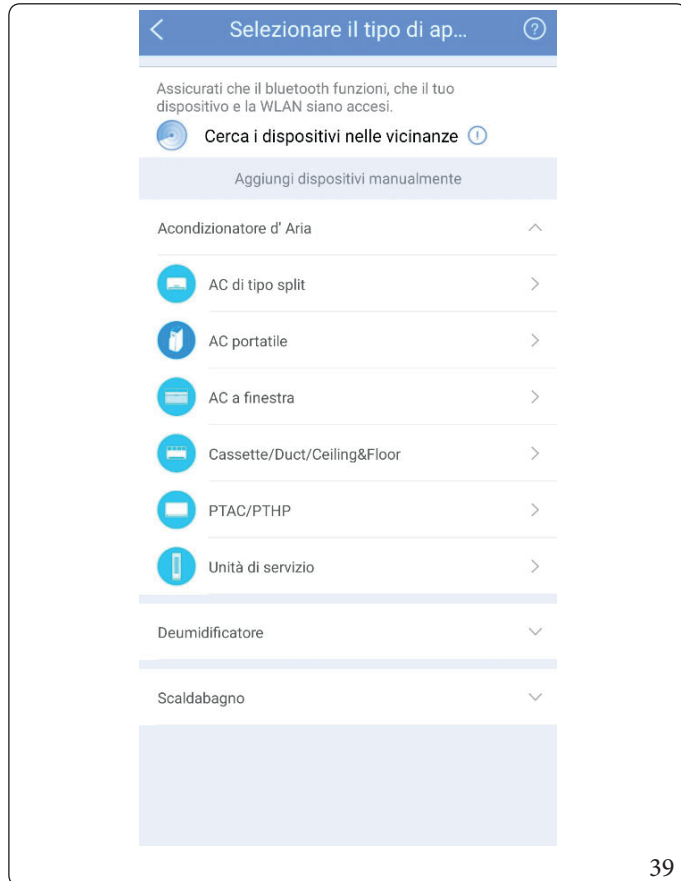

1. Manually select the product type.



2. Select the name of the wireless network to which you want to connect the appliance and enter the password.



The appliance supports 2.4 GHz Wi-Fi wireless networks only.



41

- Press and hold the "Stand-by" button on the display (F, Fig.) for 3 seconds. The flashing wireless connection symbol will light up in the top right corner of the display.

- The appliance displays a temporary wireless network, called 'net_cd_xxxx', which you can connect to using your mobile phone by entering the password '12345678'.

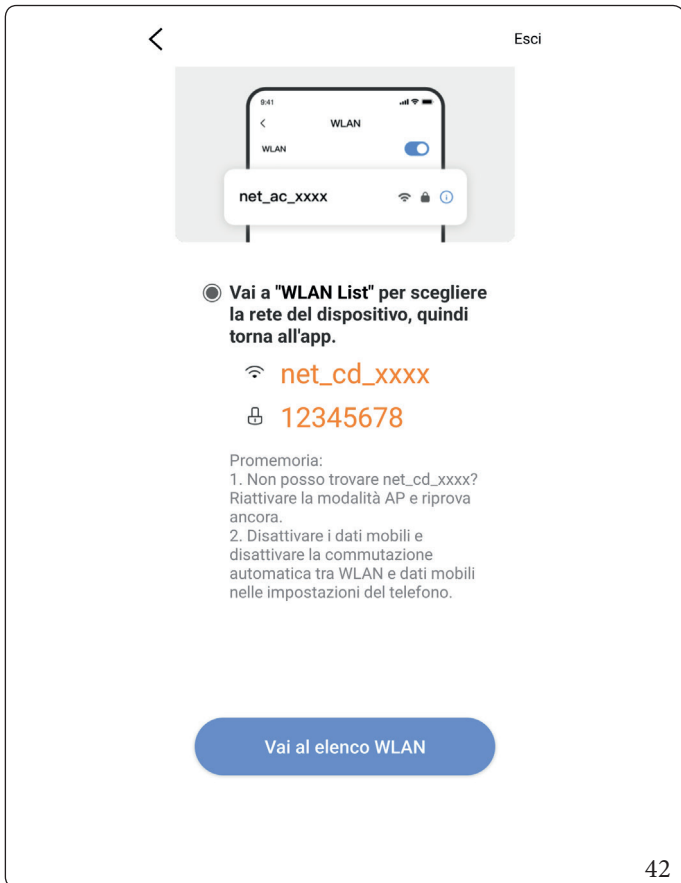

42



43



✕



Connettersi con successo

Nome dispositivo consigliato:

Soggiorno Sala da pranzo

Cucina Camera da letto

Camera dei bambini Studio

Camera degli ospiti Ripostiglio

Nome dispositivo personalizzato:

Scaldabagno 

Salva

44

5. Device set-up was successful, now you can change the appliance name.

2.5.6 How to use the App

Make sure the appliance is connected to the Wireless network (see par. 2.5).

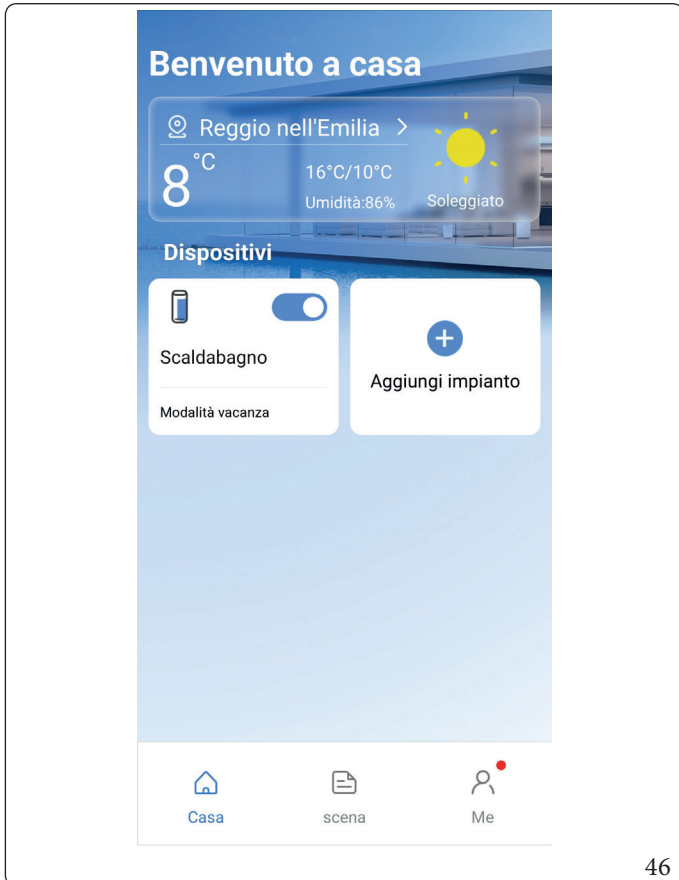
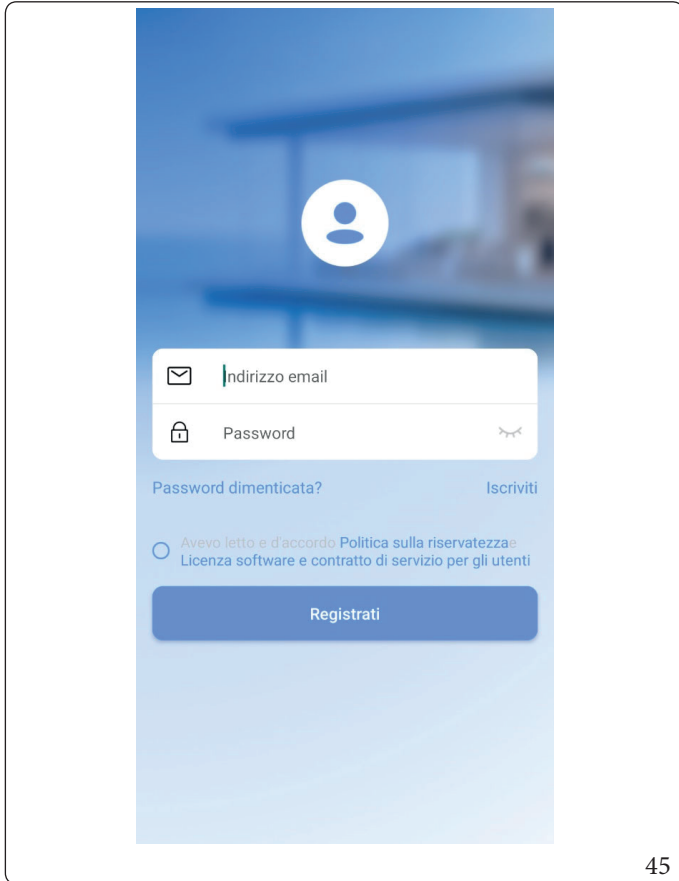

1. Please login.
2. If you've forgotten your password, click "Forgot your password?" and follow the steps in the App.

3. Select the appliance to be controlled.
4. The available functions are displayed on the appliance screen.

INSTALLER

USER

MAINTENANCE TECHNICIAN

TECHNICAL DATA



2.5.6.1 Operating mode

The available modes are (refer to Par. 2.2.1):

Smart mode

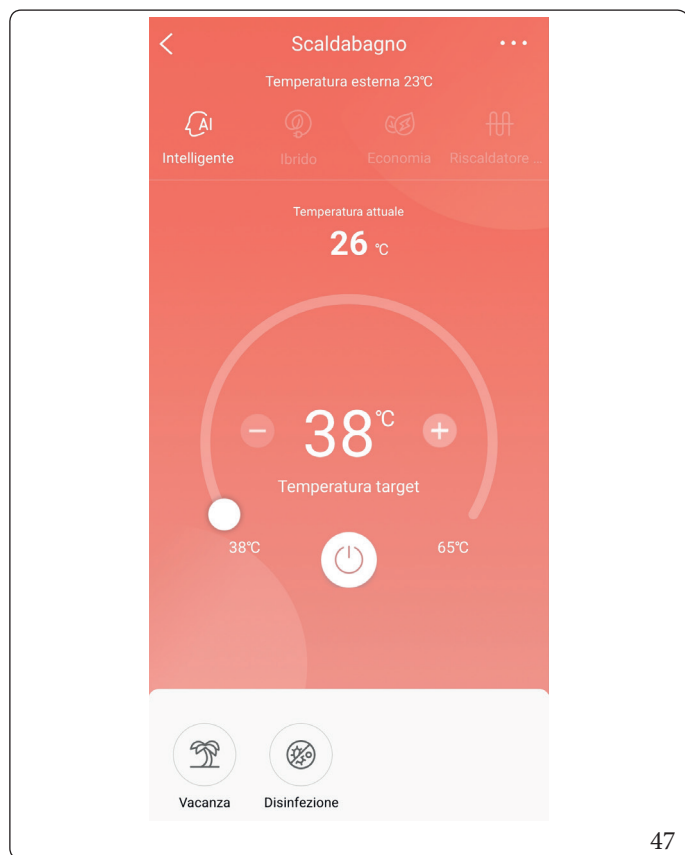

47

Hybrid mode

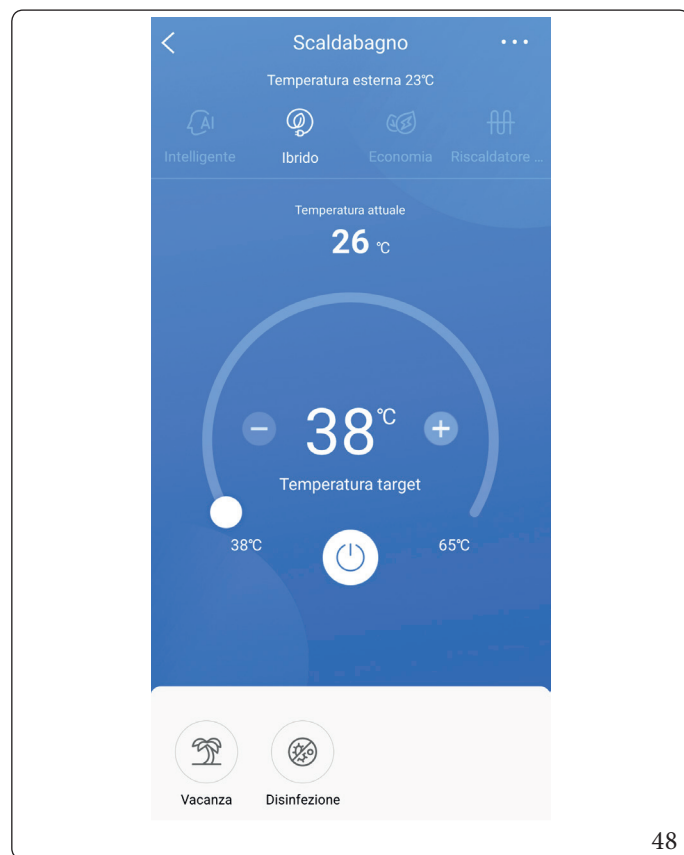

48

Energy saving mode

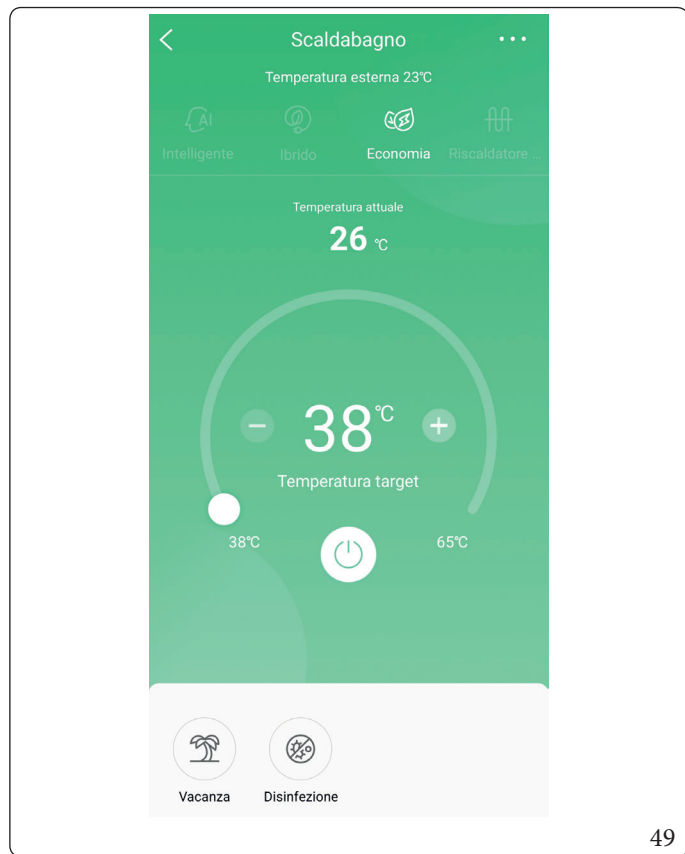

49

Electricheater mode (E-HEATER)

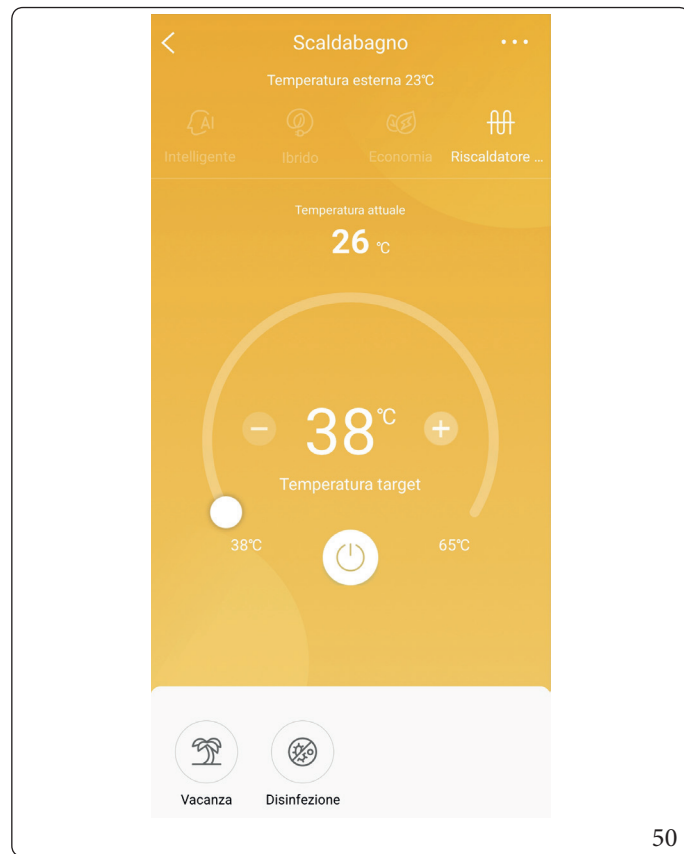

50

2.5.7 Special functions

The following information is present in the submenu (reference Par. 2.2.1 and Par. 2.3):

Holidaymode

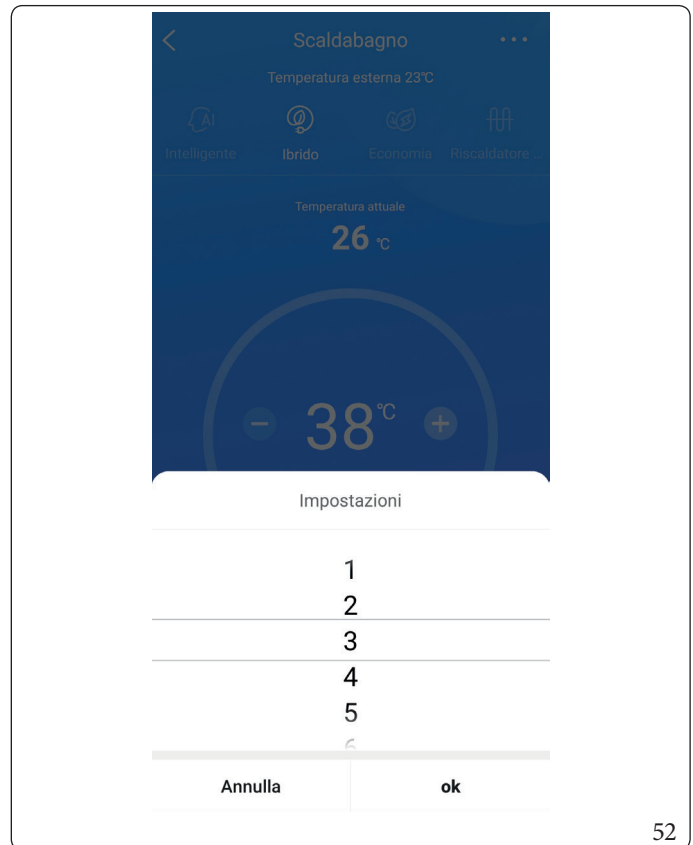
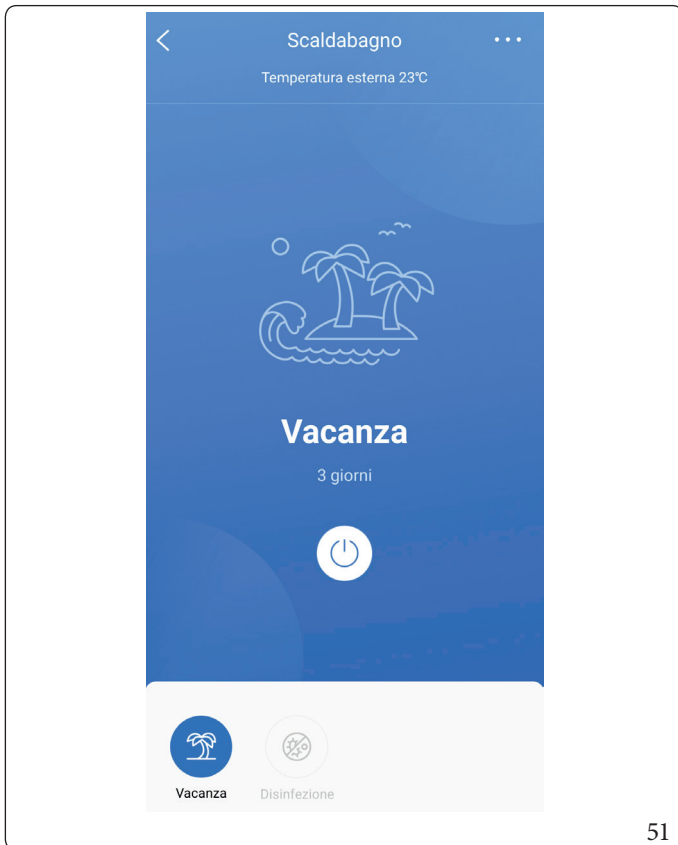

Function

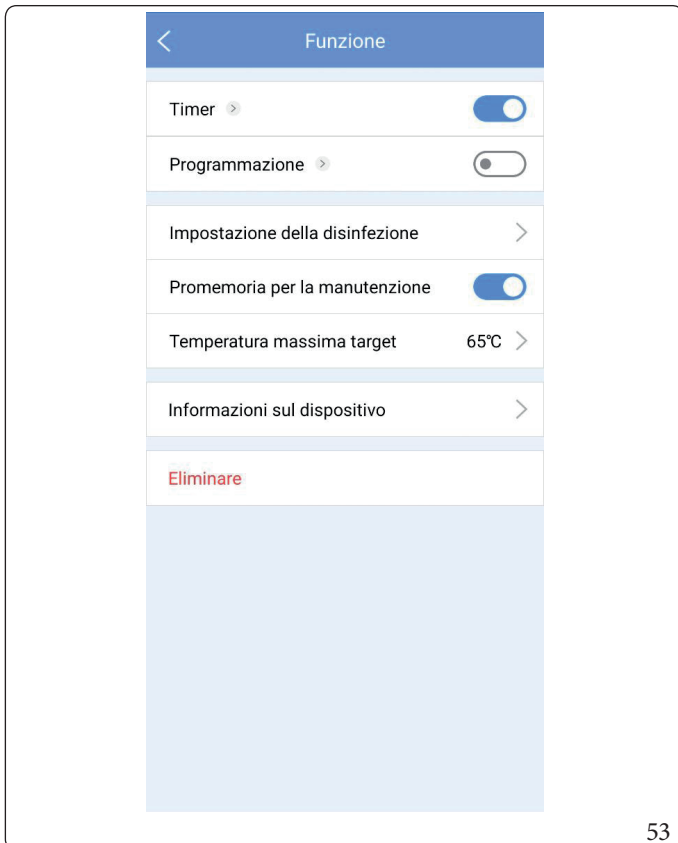

Timer

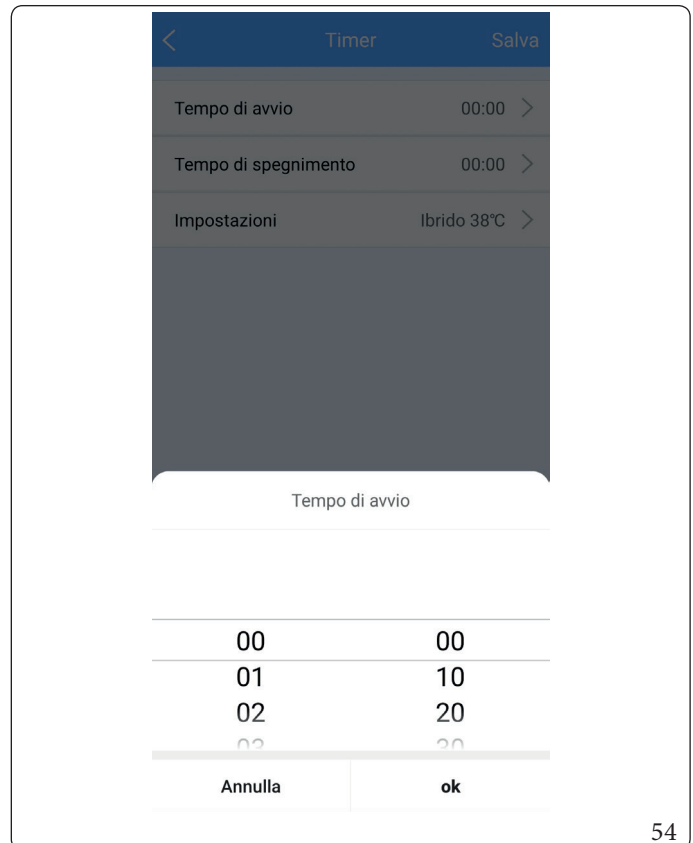

INSTALLER

USER

MAINTENANCE/TECHNICIAN

TECHNICAL DATA



Schedule

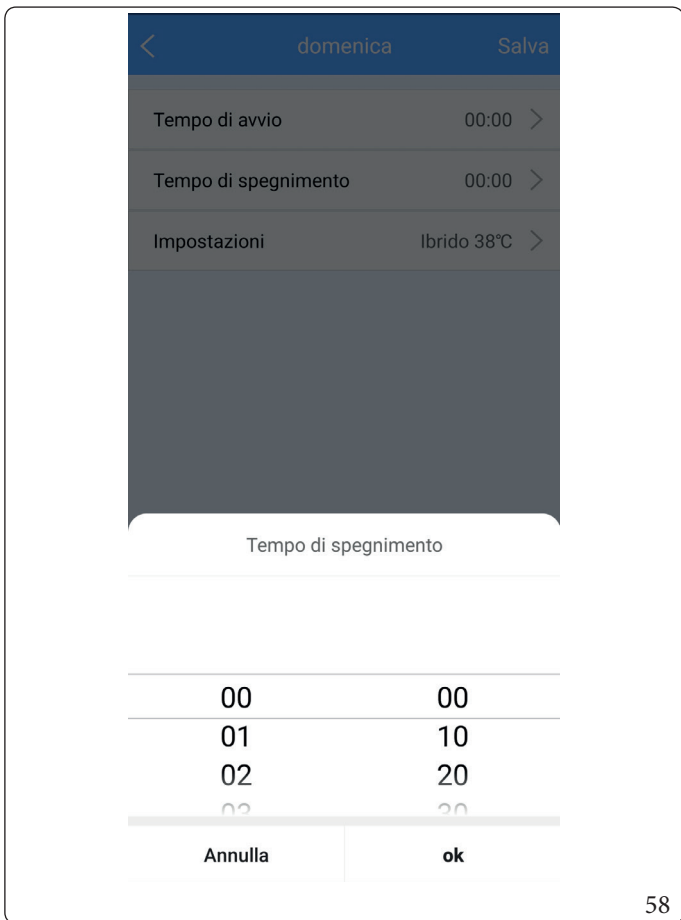
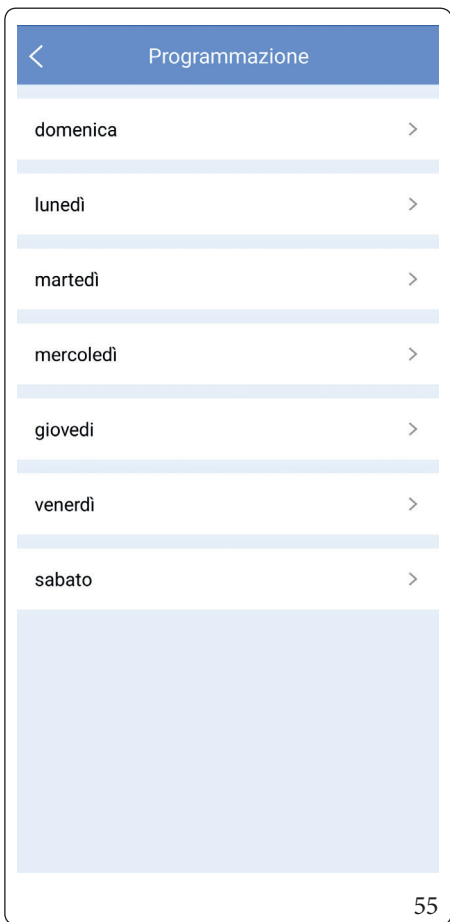

Disinfect

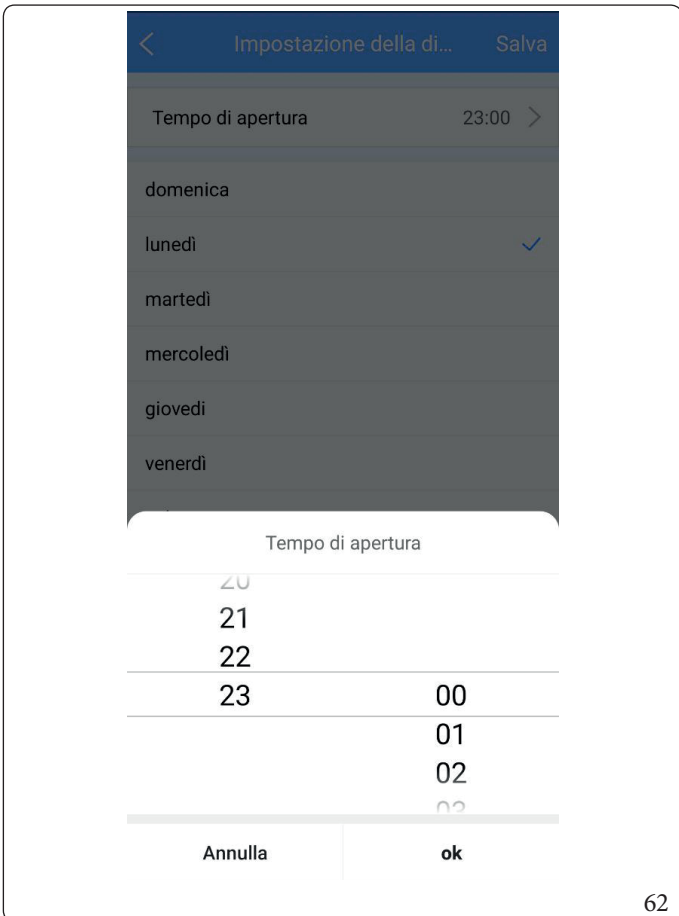
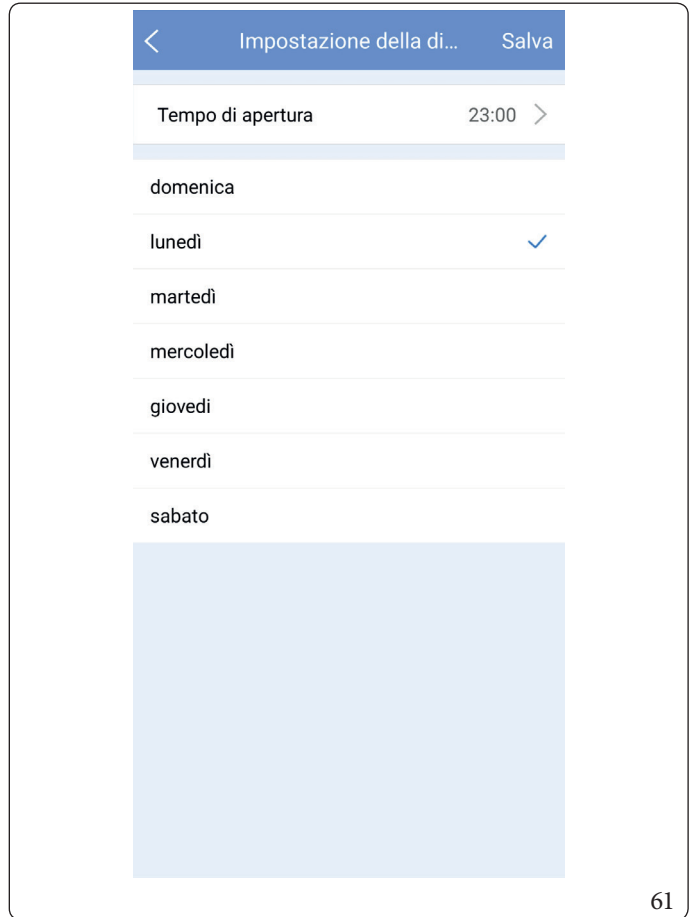
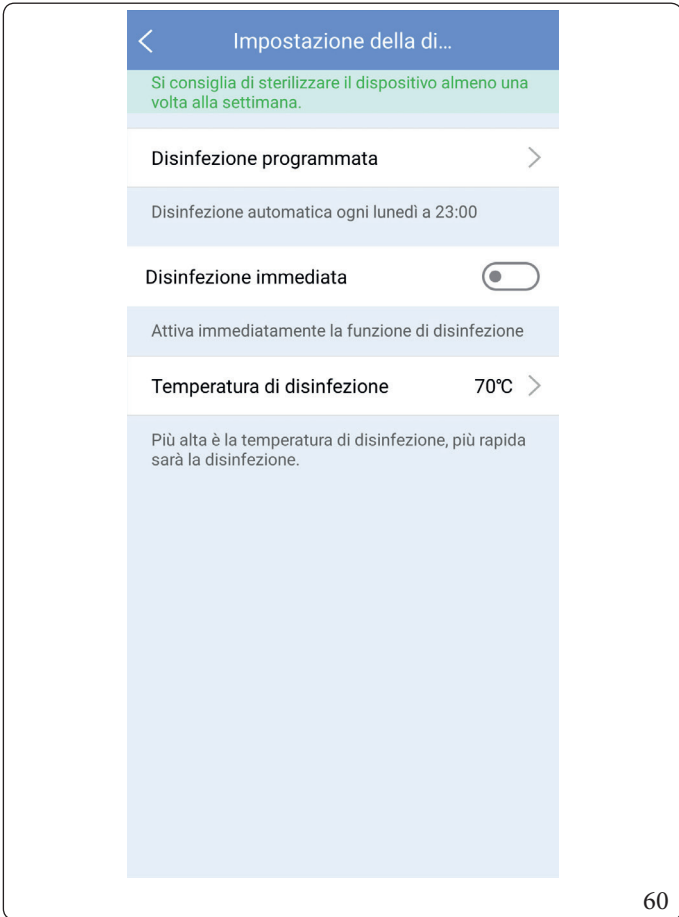

INSTALLER

USER

MAINTENANCE/TECHNICIAN

TECHNICAL DATA



Maximum target temperature



64

Device information

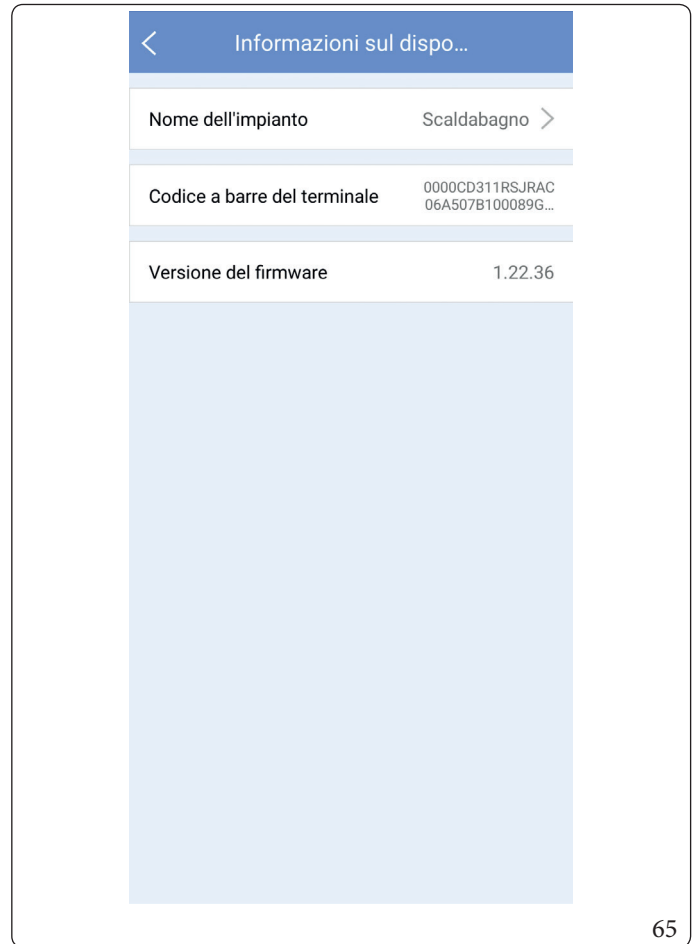

65

2.5.8 Compliance

We hereby declare that this device complies with the relevant provisions of the RED Directive 2014/53/EU.

For appliances intended for the European Union, the complete copy of the Declaration of Conformity is as follows:

- The manufacturer, Immergas, declares that the type of radio equipment RAPAX 100 V4 complies with Directive 2014/53/EU.
- The full text of the EU declaration of conformity is available at the following Internet address: www.immergas.com

Wireless module models:

- EU-SK110, US-SK110:
- FCC ID: 2ADQOMDNA23
- IC: 12575A-MDNA23
- BLE: 2402-2480MHz
- TX Power: <10dBm
- Wireless: 2400-2483.5MHz
- TX Power: <20dBm

This device complies with Part 15 of the FCC standards and contains license-exempt transmitters/receivers that comply with Canada's Radio Standards Specifications (RSS) for Innovation, Science and Economic Development (ISED).

Operation is subject to the following two conditions:

1. This device must not cause harmful interference;
2. This device must accept any interference, including interference that may cause undesired operation of the device.

The appliance must only be used in strict accordance with the instructions provided. Any changes or modifications to this equipment, not expressly approved by the party responsible for compliance, could void the user's authority to operate it.

This equipment complies with FCC radiation exposure limits set forth for uncontrolled environments. To ensure that radio frequency (RF) exposure limits are not exceeded, the user must maintain a minimum separation distance of 20 cm (8 inches) from the antenna during normal operation of the appliance.



2.6 FAULT AND ANOMALY SIGNALS

Anomaly	Causes	Solutions
Delayed Compressor Start	The appliance waits 3 minutes before restarting the compressor.	This function is not a malfunction but an automatic procedure by the appliance.
Decrease in the temperature displayed during operation of the appliance	The anomaly occurs when the water temperature in the upper part of the tank is much higher than that in the lower part. The hot water at the top mixes with the cold water that continuously flows from the inlet pipe. This combination causes a decrease in temperature at the top of the tank.	If the anomaly persists, contact the authorised service centre.
Sudden decrease in the temperature shown on the display	The fault is caused by the pressurised tank; if there is a high demand for hot water, it is quickly drawn from the upper part of the tank, while cold water quickly enters the lower part. If cold water reaches the upper temperature sensor, the temperature shown on the display will drop rapidly.	If the anomaly persists, contact the authorised service centre.
Sudden decrease in temperature on the display but hot water still available	The fault is caused by the water sensor located in the upper area of the tank; if the temperature on the display begins to decrease, there will still be 1/4 of the hot water available in the tank.	If the anomaly persists, contact the authorised service centre.
"EHLA" fault displayed	When the appliance does not have the electrical heating function, the heat pump can only operate within an inlet air temperature range of -7 to 43°C. If the inlet air temperature falls outside this range, the system will alert the user by displaying a notification on the display.	If the anomaly persists, contact the authorised service centre.
Buttons not operating	If the panel is not used for 60 seconds, the appliance locks the display by showing the "🔒" symbol.	Press the buttons G+H simultaneously (Fig. 28) to unlock the display.
Water leaking from the one-way valve drain pipe	The anomaly is due to the fact that the tank is pressurised; when the water inside the tank is heated, it expands, causing an increase in internal pressure. If the pressure exceeds 1.0 MPa, the one-way valve activates to release the excess pressure. As a result, a certain amount of hot water is discharged.	If water drips continuously from the one-way valve drain pipe, contact a qualified technician for repair.
The tap water is cold and the display screen is off.	1. Incorrect connection between power plug and socket; 2. Water temperature setting too low; 3. Broken temperature sensor; faulty system board.	1. Insert the plug; 2. Set a higher temperature; 3. Contact the authorised service centre.
No hot water comes out of the tap.	1. Public water system interruption; 2. The cold water inlet pressure is too low (< 0.15 MPa); 3. Domestic cold water inlet tap closed.	1. Waiting for the public water system to be restored; 2. Waiting for increase in inlet water pressure; 3. Open the domestic water inlet tap.
Water leaks	The hydraulic pipe joints are not sealed properly. Breakage of a pipe or fitting.	Check and tighten all joints. Check the pipes.



- If common errors occur, the appliance will automatically switch to electric heater mode to ensure emergency domestic hot water supply. Contact qualified personnel for repairs.
- If serious errors occur and the appliance does not start, contact qualified technicians for repair.



2.7 ERROR CODES

Error code	Description	Remedy
EH0b	Communication error between tank and LCD panel.	Check that the connection between the LCD panel and the board is correct Check that the board is not faulty. Contact a professionally qualified technician for maintenance of the appliance.
EH00	Anomaly in the machine operating parameters.	Contact a professionally qualified technician for maintenance of the appliance.
EH03	DC fan fault.	Check that the connection between the fan and the board is correct Check that the fan is not broken. Contact a professionally qualified technician for maintenance of the appliance.
PH15	Electrical leakage error. When the circuit detects that the current difference between the phase (L) and neutral (N) conductors is greater than 14 mA, the system interprets this condition as an "electrical leakage error".	Check that the power supply cables are connected correctly. Contact a professionally qualified technician for maintenance of the appliance.
EC54	Error of compressor drain temperature sensor TP.	Check that the connection between the sensor and the board is correct. Check that the sensor is not faulty. Contact a professionally qualified technician for maintenance of the appliance.
EH5H	Error of compressor intake temperature sensor TH.	Check that the connection between the sensor and the board is correct. Check that the sensor is not faulty. Contact a professionally qualified technician for maintenance of the appliance.
EC53	Error of ambient temperature sensor T4.	Check that the connection between the sensor and the board is correct. Check that the sensor is not faulty. Contact a professionally qualified technician for maintenance of the appliance.
EC52	Error of evaporator temperature sensor T3.	Check that the connection between the sensor and the board is correct. Check that the sensor is not faulty. Contact a professionally qualified technician for maintenance of the appliance.
EH5L	T5L sensor error (lower water temperature)	Check that the connection between the sensor and the board is correct. Check that the sensor is not faulty. Contact a professionally qualified technician for maintenance of the appliance.
EH5U	T5U sensor error (higher water temperature)	Check that the connection between the sensor and the board is correct. Check that the sensor is not faulty. Contact a professionally qualified technician for maintenance of the appliance.
EHLA	When the room temperature value T4 is out of the compressor operating range, the appliance stops and the "EHLA" fault is displayed. The fault persists until the T4 value returns to the operating range. This operation is only valid on appliances without electric heater. The "EHLA" fault never occurs on appliances with electric heater.	No intervention required

Error code	Description	Remedy
EH5d	Electric heater open circuit error	Check that the electric heater cables are connected correctly. Check that the heating element is not broken. Contact a professionally qualified technician for maintenance of the appliance.
EHHP	Heat pump fault. The alarm is activated when error codes PH20, PH21, PC30, PC06 are displayed; when any protection is activated 3 times in a row or if any of the protections remains active for 1 hour.	The compressor is working abnormally. Contact a professionally qualified technician for maintenance of the appliance.
PHdH	Overheating alarm displayed.	Make sure there is water in the tank before starting the heating cycle.
PH20	Alarm displayed due to abnormal compressor shut-down. After a certain period of operation of the compressor, the discharge temperature is not high enough compared to the evaporator temperature.	Check that the connection between the compressor and the board is correct. Check that the compressor is not faulty. Contact a professionally qualified technician for maintenance of the appliance.
PH21	The compressor current draw is too high.	Check that the compressor is not broken Possible system blockage, water temperature sensor malfunction, etc. Contact a professionally qualified technician for maintenance of the appliance.
PH24	Alarm displayed due to frost ($T_{5L} < 4^{\circ}\text{C}$ and $T_4 < 7^{\circ}\text{C}$)	The cold water temperature is too low. This anomaly may affect the water tank. The electric heater will still work.
PC30	High pressure alarm displayed: $\geq 3,0\text{MPa}$ active; $\leq 2,4\text{Mpa}$ inactive	Possible system blockage, water temperature sensor malfunction, etc. Contact a professionally qualified technician for maintenance of the appliance.
PC06	High temperature alarm displayed $T_p > 110^{\circ}\text{C}$ active protection $T_p < 90^{\circ}\text{C}$ inactive protection	Possible system blockage, water temperature sensor malfunction, etc. Contact a professionally qualified technician for maintenance of the appliance.
PH9b	Overheating alarm displayed. The displayed water temperature exceeds the set temperature (+5 °C).	The water temperature sensor is defective or the current water temperature is too high. Contact a professionally qualified technician for maintenance of the appliance. Burn hazard
PH91	Alarm displayed: value detected by sensor T3 too low.	If the problem persists, contact a professionally qualified technician for maintenance of the appliance.

INSTALLER

USER

MAINTENANCE TECHNICIAN

TECHNICAL DATA



3 INSTRUCTIONS FOR MAINTENANCE AND INITIAL CHECK

3.1 GENERAL RECOMMENDATIONS

INSTALLER



Operators who install and service the appliance must wear the suitable personal protective equipment (PPE) required by applicable law. The list of possible PPE is not all-comprehensive as it is indicated and chosen by the Employer of the authorised company (installer or maintenance).

USER



Before carrying out any maintenance work, make sure that:
– Always turn off your heat pump water heating system and disconnect the electrical power before cleaning or maintenance.



Components must be replaced exclusively by a professionally qualified technician. Users are not allowed to proceed with disassembly.



- Before cleaning, stop the appliance by turning off the switch or unplugging it. Otherwise, you may receive an electric shock and suffer injury.
- Contact qualified personnel when moving, repairing or maintaining the appliance. Never do it alone.

MAINTENANCE TECHNICIAN

3.2 APPLIANCE CHECK AND MAINTENANCE



- Regularly check the connection between the power plug and the power outlet, including checking for proper earthing.
- If the appliance is located in a cold environment (with temperatures below 0°C) and a prolonged shut-down is expected, it is mandatory to completely drain all the water from inside it. This operation is necessary to avoid freezing of the internal tank and the potential damage that would result, including failure of the electric heater.
- It is recommended to clean the internal tank and the electric heater every six months to maintain optimal system efficiency. For this operation, please contact your supplier or after-sales service.
- Check the sacrificial anode every six months and replace it if it is worn. For more information or replacement, please contact your supplier or after-sales service.
- To optimise energy efficiency, prevent limescale build-ups, and reduce heat loss, we recommend setting the hot water temperature to the lowest possible value consistent with user comfort.
- It is recommended to clean the air filter every month to prevent a reduction in heating performance efficiency. For filters mounted directly on the air inlet, unscrew the air inlet ring, remove the filter, clean it thoroughly and finally reassemble it correctly in the appliance.
- Before shutting down the system for an extended period of time, you should:
 - cut off the power supply;
 - drain all the water contained in the tank and inside the pipes, closing all the valves;
 - Check internal components regularly during inactivity.

TECHNICAL DATA



- Reset the safety temperature limiter; contact your supplier or after-sales service for further information. Before resetting the limiter, make sure that:
 - the intervention was not caused by an energy saving function or a previously activated time program;
 - Check whether the electric heater safety limiter has been activated due to overheating (temperature above 85°C) or another type of fault.



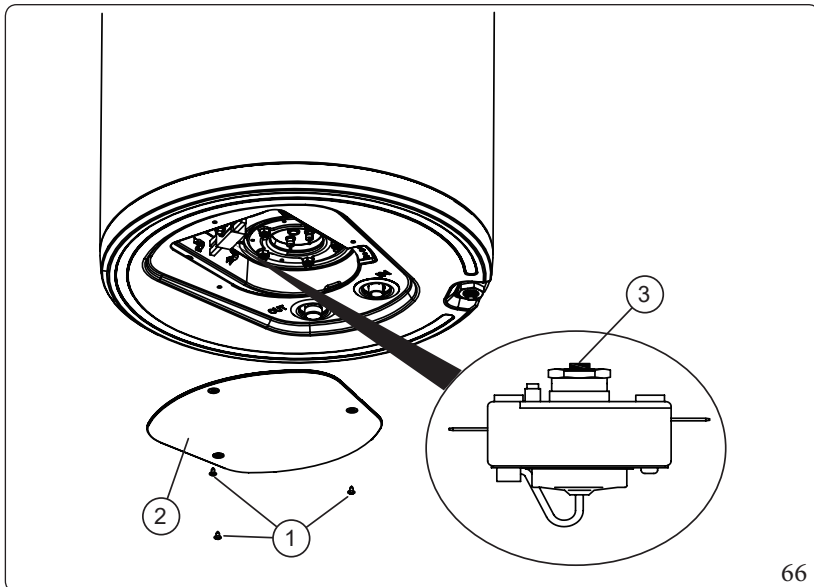

To reset the limiter, loosen the screws (A, Fig. 66) under the appliance, remove the cover (B, Fig. 66) and press the reset button (C, Fig. 66).

Key (Fig. 66):

- A - Screws
- B - Cover
- C - Reset button

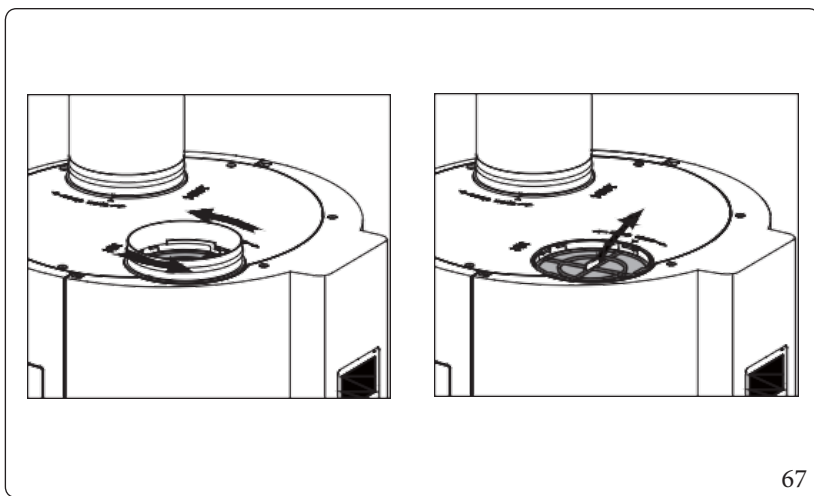

If the appliance is used in a dirty or dusty environment, it is necessary to install the filter in the appropriate intake air fitting. If you notice inefficient heating performance, we recommend cleaning the air filter.

Regarding the filter installed directly in the air inlet (i.e., without connection to a duct):

- unscrew the air duct connector anti-clockwise;
- remove the filter and clean it completely;
- reassemble it on the appliance.



Checking and replacing the sacrificial anode

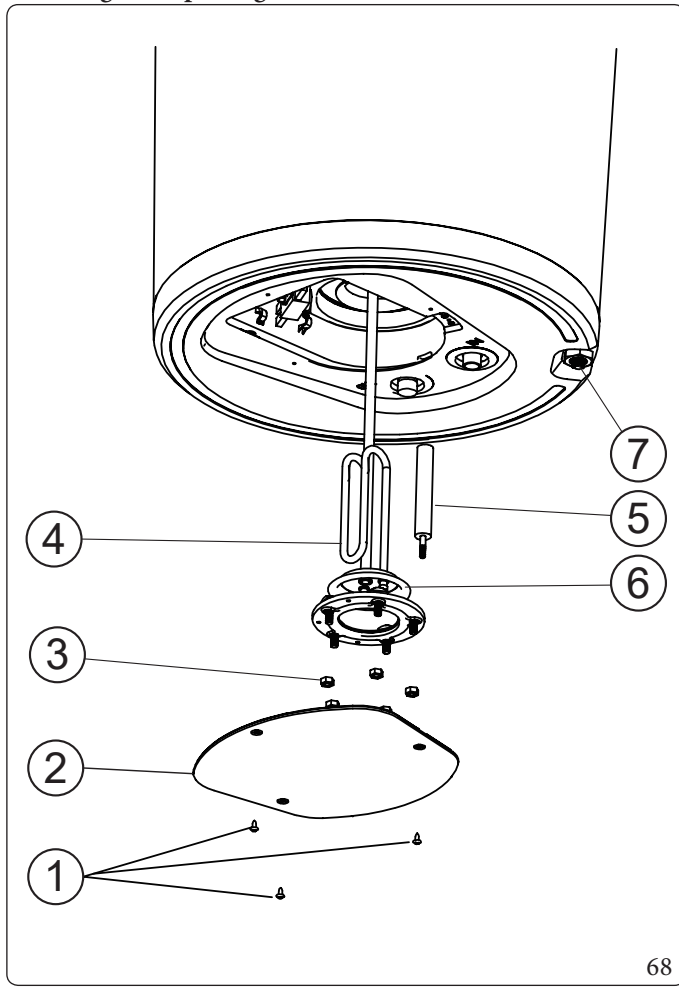

- Empty the appliance completely.
- Loosen the screws (1, Fig. 68) placed under the structure.
- Remove the cover (2, Fig. 68).
- Remove the cable connected to the electric heater (4, Fig. 68).
- Loosen the nuts (3, Fig. 68) retaining the heating element.
- Remove the entire unit, which includes the electric heater (4, Fig. 68), the anode (5, Fig. 68) and its seal (6, Fig. 68).
- Unscrew the anode (5, Fig. 68) and remove it from the electric heater (4, Fig. 68).
- Check the removed anode for wear (5, Fig. 68) and that the diameter of the latter is greater than 16mm.
- Check for limescale deposits on the heating element (4, Fig. 68);
- If the anode is worn (for example, if the diameter is less than 16 mm) or the wear is uneven, replace it.
- Replace the seal (6, Fig. 68) during the reassembly phase of the unit.

Key (Fig. 68):

- 1 - Screws
- 2 - Cover
- 3 - Nuts
- 4 - Electric heater
- 5 - Sacrificial anode
- 6 - Gasket
- 7 - Draining valve / tap

3.3 LIST OF ORDINARY MAINTENANCE OPERATIONS

Unit	Control frequency	Action
Air filter (inlet)	every month	Clean the filter
Anode	every six months	Replace if worn
Internal tank	every six months	Cleaning the tank
Electric heater	every six months	Electric heater cleaning
One-way valve	every month	Check for any obstructions



For more information, please contact the supplier or after-sales service.

4 TECHNICAL DATA

4.1 TECHNICAL DATA TABLE

Appliance data

		Rapax 100 V4
Weight and dimensions		
Full unit weight	kg	166,0
Empty unit weight	kg	66,0
Dimensions (LxHxD)	mm	500 x 1365 x 548
Coolant		
Type of refrigerant		R290
Coolant load	g	150
Fan		
Type		-
Nominal air flow	m ³ /h	200
Permissible pressure drops on the air duct circuit	Pa	60
Absorbed electric power	W	15
Evaporator		
Type of fins		hydrophilic aluminium
Pipe type		copper with internal groove
Condenser		
Type		Microchannel
Appliance with packaging		
Weight with packaging	kg	72,0
Dimensions of unit with packaging (LxHxD)	mm	620 x 1450 x 585
Storage room temperature	°C	-
Power supply electrical features		
Electrical connection		220 - 240V ~ 50Hz
Maximum absorbed power	W	1950
Rated absorbed current	A	9,0
Absorbed power without integration resistance	W	450
Absorbed current without integration resistance	A	-
Integration heating element absorbed current (DHWEH)	W	1500
Integration heating element absorbed current (DHWEH)	A	-
Power cable features		
Type of cable		-
MFA (maximum fuse current) without DHWEH	A	5
Fuse type without DHWEH		T
MFA (maximum fuse current) with DHWEH	A	16
Fuse type with DHWEH		T
Minimum power supply cable cross-section	mm ²	1,5
Minimum earthing cable cross-section	mm ²	1,5

INSTALLER

USER

MAINTENANCE TECHNICIAN

TECHNICAL DATA



		Rapax 100 V4
Other electrical data		
Protection class		IP21
DHW Tank Data		
Material		-
Insulation thickness	mm	-
Domestic water content	l	98
Maximum working pressure	bar	8,0
Maximum domestic water temperature	°C	70
Minimum cold water inlet pressure	bar	-
Maximum cold water inlet pressure	bar	5
Recommended cold water inlet pressure	bar	3 ~ 4
Safety valve - Calibration	bar	8,0
Safety valve - Size	inches	1/2"
Heat exchange surface	m ²	-
Maximum working pressure	bar	-
Material		-
Nominal volume	l	-
Usable volume	l	-
Precharge	kPa (bar)	-
Corrosion protection		Magnesium anode, Vitreous enamel-coated steel
Sound power		
Sound power indoors (without duct)	dB(A)	54
Sound power outdoors (with duct)	dB(A)	-

Product data.

		Rapax 100 V4
DHW		
Adjustable DHW temperature	°C	+38 ÷ +70
Room temperature	°C	0 ÷ +43
Inlet air temperature during heat pump operation	°C	-7 ÷ +43
Inlet air temperature for integration heating element operation	°C	-20 ÷ +45



4.2 PRODUCT FICHE RAPAX 100 V4 (IN COMPLIANCE WITH REGULATION 811/2013)

A	Supplier's name or trademark	-	Immergas
B	Supplier's model identifier	-	Rapax 100 V4
C	For water heating	Stated load profile	M
D	Energy efficiency class of water heating	-	A+
E	Energy efficiency of water heating (average climate condition)	%	111
F	Annual energy consumption for water heating (average climate condition)	kWh	463
G	Additional load profile	-	-
	Water heating energy efficiency	kWh	-
	Annual energy consumption for water heating	%	-
H	Thermostat temperature setting	°C	53
I	Lwa sound power level indoors	dB	54
I	Lwa sound power level outdoors	dB	-
J	Operation only during dead hours	-	No
K	Specific precautions	-	-
L	Smart value	-	1
L1	Weekly energy consumption with smart control (average climate condition) $Q_{elec,week,smart}$	kWh	9,450
L2	Weekly energy consumption without smart control (average climate condition) $Q_{elec,week}$	kWh	10,500
M	Energy efficiency of water heating (colder climate condition)	%	92
	Energy efficiency of water heating (hotter climate condition)	%	114
N	Annual energy consumption for water heating (colder climate condition)	kWh	558
	Annual energy consumption for water heating (warmer climate condition)	kWh	451

4.3 DHW PERFORMANCE (EN16147) (RAPAX 100 V4)

Climate conditions		Averages	Hot	Cool
Energy class		A+	-	-
Stated load profile		M	-	-
Daily electrical power consumption (Q_{elec})	kWh	2,435	2,133	2,631
Annual electrical power consumption (AEC)	kWh	463	451	558
Energy Eff. Water heating (η_{wh})	%	111	114	92
Daily fuel consumption (Q_{fuel})	kWh	-	-	-
Annual Fuel Consumption (AFC)	GJ	-	-	-
V40 (water mixed at 40°C) (V40)	l	110	-	-
Seasonal coefficient of performance ($_{DHW} SCOP$)		2,61	-	-
Heating time (t_h)	h:min	6:04	-	-
Thermostat temperature	°C	52,7	-	-
Stand-by power (P_{es})	W	19	-	-

Nominal performance		
(*) Heat output:	W	980

(*) Air temperature 15/12°C (DB/WB), inlet water temperature 15°C, outlet water temperature 45°C

INSTALLER

USER

MAINTENANCE TECHNICIAN

TECHNICAL DATA







