



Cascade and zone regulator

Zone manager

Thermoregulation for boilers

IE

Instructions and warning book
for the users



TABLE OF CONTENTS

Introduction	4
Visualization and control elements	4
Operation.....	5
Keys function	6
Temperature settings	6
Operational mode selection for heating and domestic hot water	7
Functions of operational modes.....	8
Setting the heating characteristics (heating curve).....	9
System information	10
Programming of the thermoregulation system	12
Programming of functioning parameters	12
Programming of operating times	14
Copying operating times	16
Return loading of standard programs: deleting of individual operating-times programs	18
Parameters configuration	20
Setting of system parameters (for the technician).....	20
Domestic hot water parameters setting	23
Heating circuits parameters setting (direct circuit, mixed circuit 1, mixed circuit 2) (for technician)	24
Time - date.....	26

Error messages	27
Special operating modes (for technician)	28
Emission measurement.....	28
Manual mode (for technician)	29
Product specifications	30

Visualization and control elements.

Cascade and zones regulator VICTRIX 50

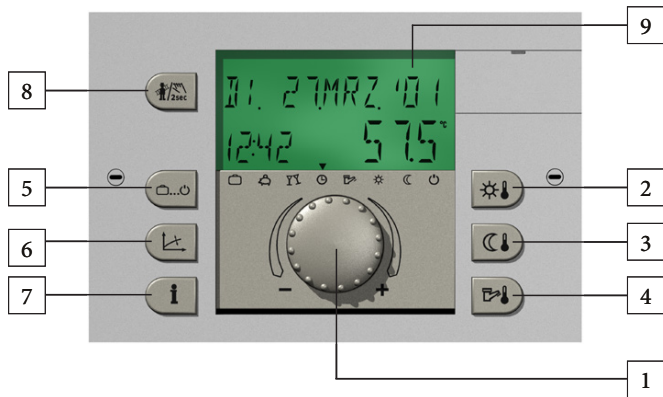

- 1 - Main knob with two functions (turn-push)
- 2 - Setting daytime temperature
- 3 - Setting reduced temperature
- 4 - Setting domestic hot water temperature
- 5 - Heating and set back programs
- 6 - Setting heating parameters
- 7 - System information

Zone manager VICTRIX 50

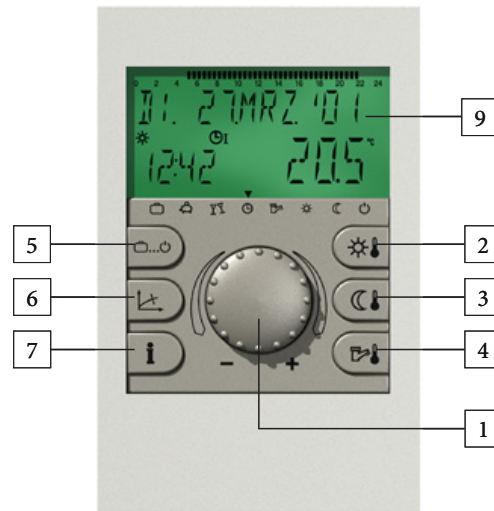

- 8 - Manual mode and emission measurement
- 9 - Backlit LCD display

Operation.

Symbols used in this manual:

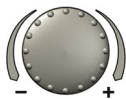

Turn: select parameters, change values



Press once: confirm, store

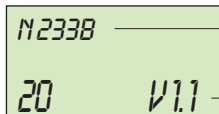

Type of instrument
Instrument information

Software version

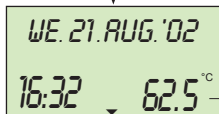

Standard display

Actual boiler temperature resp.
room temperature

The center-positioned knob and the labelled keys makes the operation simple and easy to handle.

- Each changeable value in the display appears flashing and can be modified with the knob.
Turn to the right (+) clockwise: increase values.
Turn to the left (-) anticlockwise: decrease values.
- Press once: acceptance of the selected and indicated value, store.
- Keep pressed for about 3 seconds: entry into the programming level (level selection).

The last operation step will be stored automatically after approximately 60 seconds if it was not stored by touching the knob.

The LCD display:

The appliance is provided with a big LCD display. All info are displayed clearly and they are available in different languages.

Attention: this cascade and zones regulator is set in Italian language as default. In order to follow the regulation of the appliance as explained in this instruction manual, please change the language into English, as explained on page 20 “Setting of system parameters / Language choice”.

At commissioning the installation or after a power outage a segment test with automatic error diagnostic takes place. The type of instrument with its software version is then displayed.

The standard display:

The standard display shows weekday, date, time and temperature. The temperature is that of the boiler for the cascade and zones regulator. The zone manager displays room temperature instead.

Temperature settings.

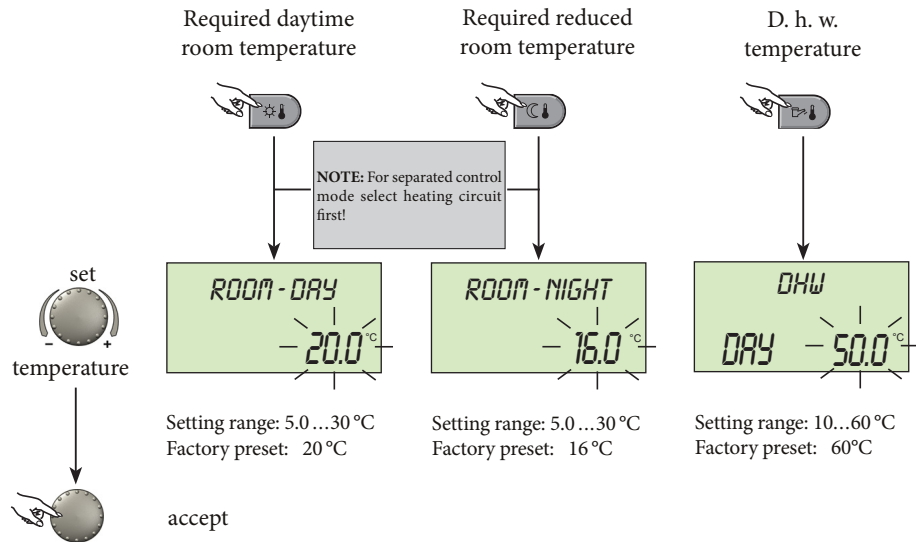

This button is used to set the daytime room temperature.



This button is used to set the required reduced temperature.



This button is used to set the required domestic hot water temperature.

To change please press the respective button; when the set value flashes, it can be changed through the knob.

The return to the standard display is done pressing the knob or automatically after 60 seconds.

Operational mode selection for heating and domestic hot water.



With this button the required operational mode is selected. It appears in plain text on the display, simultaneously an arrow at the lower edge of the display points to the appertaining symbol.

Select: Pressing the operational mode selection button, the previously set mode appears flashing. The other operational modes can be selected and activated with the knob according to the following scheme.

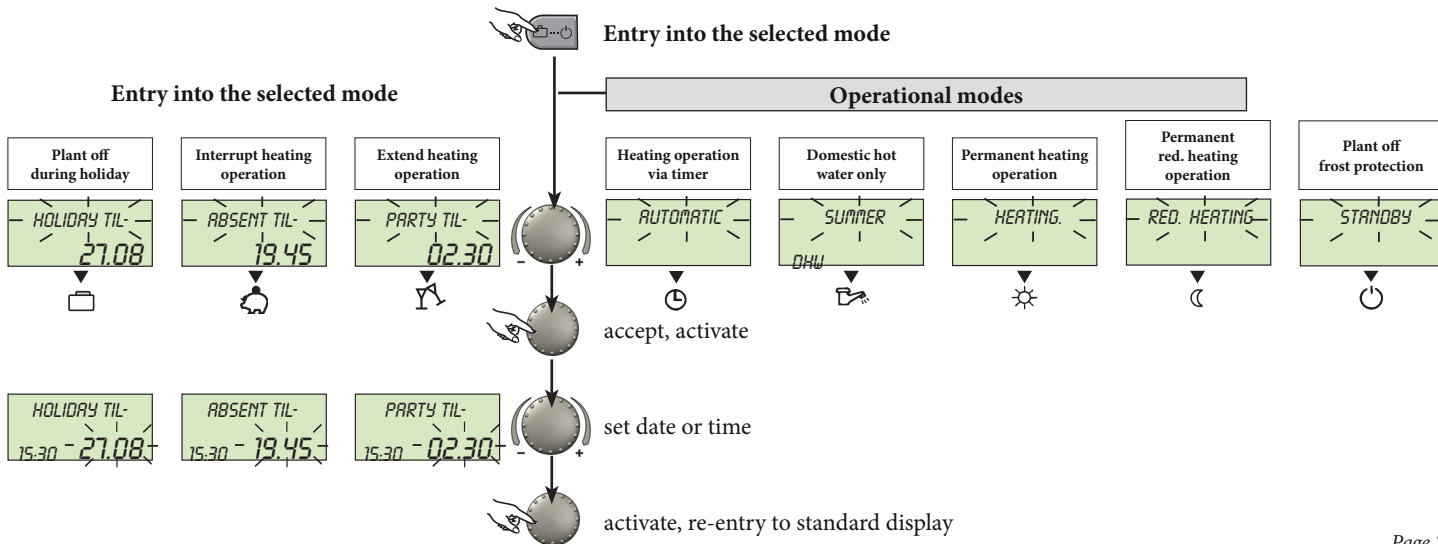

Plant off during holiday



Setting range:
Actual date...actual date + 250 days.
Return to the previously selected operational mode at 0.00 o'clock of the set return date.
Hot water operation is set to frost protection.
Earlier termination:
Press button , select required operational mode with knob and press again to activate.

Interrupt heating operation



Setting range:
P1: Heating operation is interrupted until next switching-on time of current operating times program (see page 19 operating times programs).
0.5 ...24h: Heating operation is interrupted until set time of return.
Earlier termination:
Press button , select required operational mode with knob and press again to activate.

Extend heating operation



Setting range:
P1: Heating operation is continued until next switching-on time of current operating times program (see page 19 operating times programs).
0.5 ...24h: Heating operation is continued until end of party
Earlier termination:
Press button , select required operational mode with knob and press again to activate.

Heating operation via timer



Operating times:
(see page 19 operating times programs).
Heating and domestic hot water operation automatically according to settings of temperature values and selected operating times program.
For programming individual operating times see page 14.

Domestic hot water only

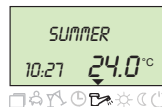

Operating times:
(see page 19 operating times programs).
Only hot water operation according to settings of hot water temperature (see page 6) and selected operating times program.
The heating operation is interrupted and frost protected.
For programming individual operating times see page 14.

Permanent heating operation

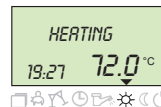

Permanent functioning of heating and d. h. w. modes according to temperatures settings (see page 6).

Permanent red. heating operation

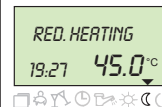

Permanent functioning of heating and d.h.w. modes according to the reduced temperatures setting (see pages 6 and 24).

Plant off frost protection



Turn off of the system with anti freeze protection on (heating and d. h. w. modes deactivated).

Setting the heating characteristics (heating curve).

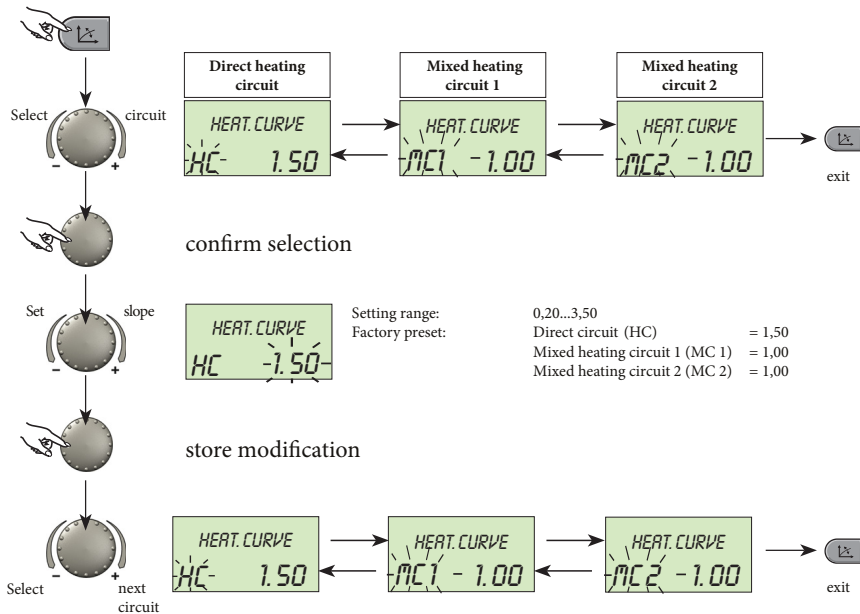



This button regulates the heating characteristics of each heating circuit in relation to outside temperature

The adjustment is independent of the system and shows the relation between outside temperature and max. heating temperature.

The slope sets the change of the max. heating temperature, if the outside temperature changes for 1 °C.

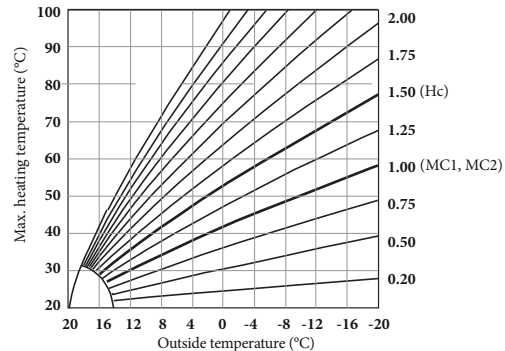
Diagram of heating curves



Re-entry into the standard display is done pressing the button  again or automatically after approx. 60 seconds.

System information.

 Entry to information level

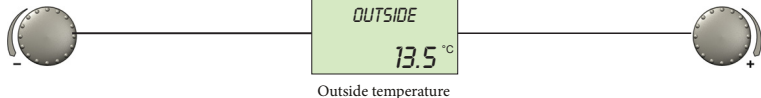

Examples:

AUTO-P1 DAY HC ON	Direct heating circuit
----------------------	------------------------

AUTO-P1 RED MC1 ON	Mixed heating circuit 1
-----------------------	-------------------------

ACTUATOR MC1 STOP	Status of mixing valve 1
----------------------	--------------------------

AUTOPIECO MC2 ON	Mixed heating circuit 2
---------------------	-------------------------

ACTUATOR MC2 CLOSE	Status of mixing valve 2
-----------------------	--------------------------

Outside temperature
minimum - maximum value between
0.00 and 24.00 h

Boiler temperature

Domestic hot water
temperature

Flow temperature
Mixed heating circuit 1

Flow temperature
Mixed heating circuit 2

OUT MIN/MAX
8.0 °C 14.5 °C

HEAT.GENER.
64.5 °C

DHW
52.0 °C

FLOW MC1
48.0 °C

FLOW MC2
35.5 °C

Examples:



The info button displays general information such as boiler water temperatures, and other conditions.

Turning the knob clockwise the display shows:

- temperatures (real and setting values)
- variable inputs (function and value)
- consumption and meters data (to visualize setting values press the knob)

Turning the knob anti-clockwise, the display shows for each heating and d.h.w. circuit:

- operational mode (holiday, absent, party, auto)
- timer program P1 (P2 or P3 after clearance)
- status of pumps (OFF, ON)
- status of mixing valve (OPEN - STOP - CLOSED)

the display also shows:

- boiler status
- room temperature
- variable output VO - 1
- variable output VO - 2

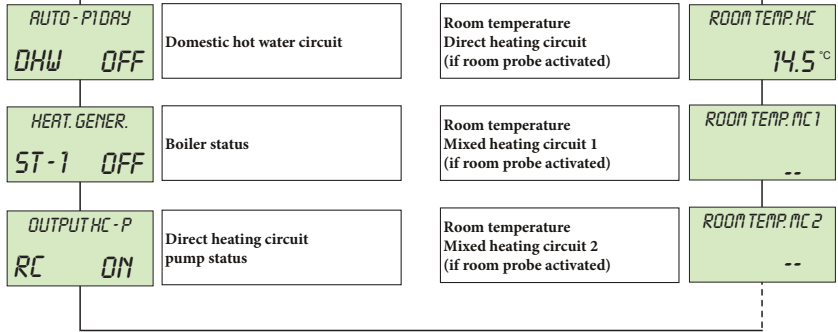

- functioning status when connecting a modem to a variable input

Standard display

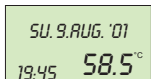

Programming of functioning parameters.

Entry into the programming level is done by pushing the knob for approx. 3 seconds during the standard display. The main parameters are already factory set, in case of modification operate as follow:

Entry into the level selection press the knob for approx. 3 seconds

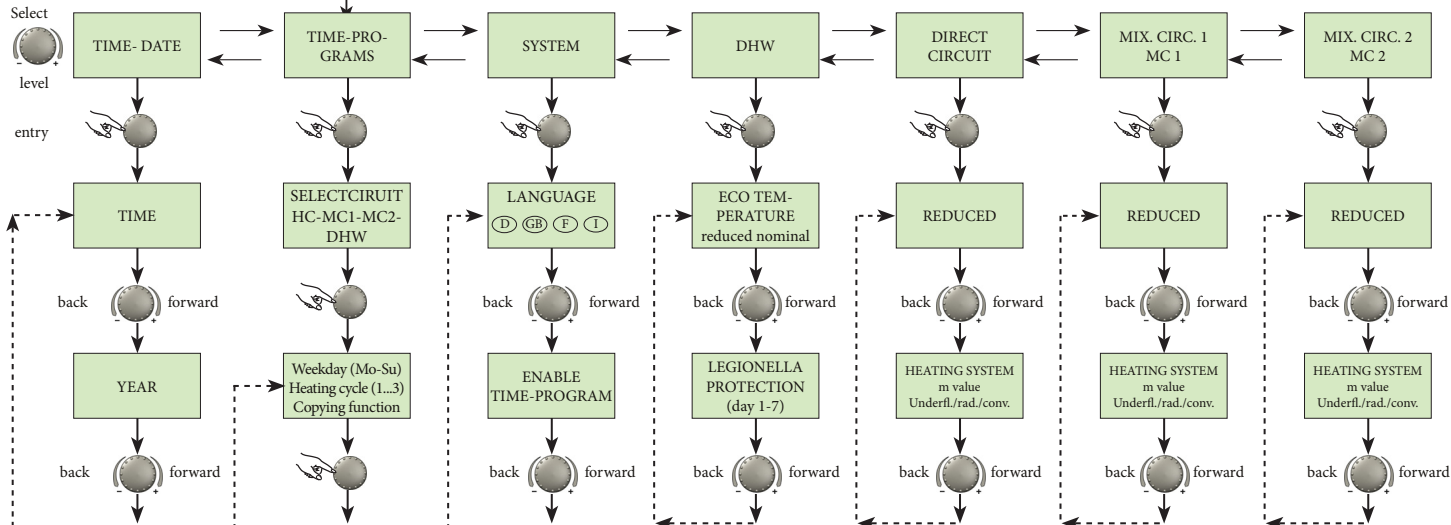

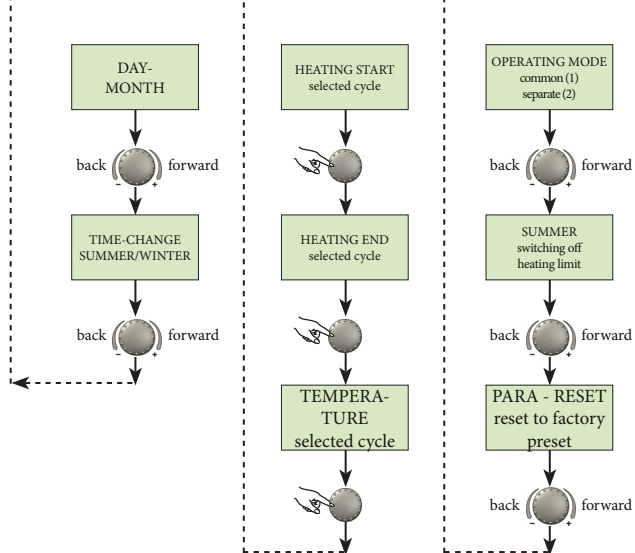

Selection and modification of parameters and setting values.

Entering into the programming level, principally the OPERATING-TIMES level appears at first.

All other levels, such as



- SYSTEM
- DOMESTIC HOT WATER CIRCUIT
- DIRECT HEATING CIRCUIT
- MIXED HEATING CIRCUIT - 1
- MIXED HEATING CIRCUIT - 2
- DATE - TIME

Can be selected directly via knob.

By pressing the knob, the selected flashing level is activated; the first value or resp. parameter appears flashing.

If necessary, it can be modified via the knob and stored by a following touch onto the knob.

If necessary, the other parameters can be treated in the same way.

Re-entry into the level selection is done via the info button , re-entry into the standard display via the program-selection button  or automatically after approx. 60 seconds.

For further information see page 20.

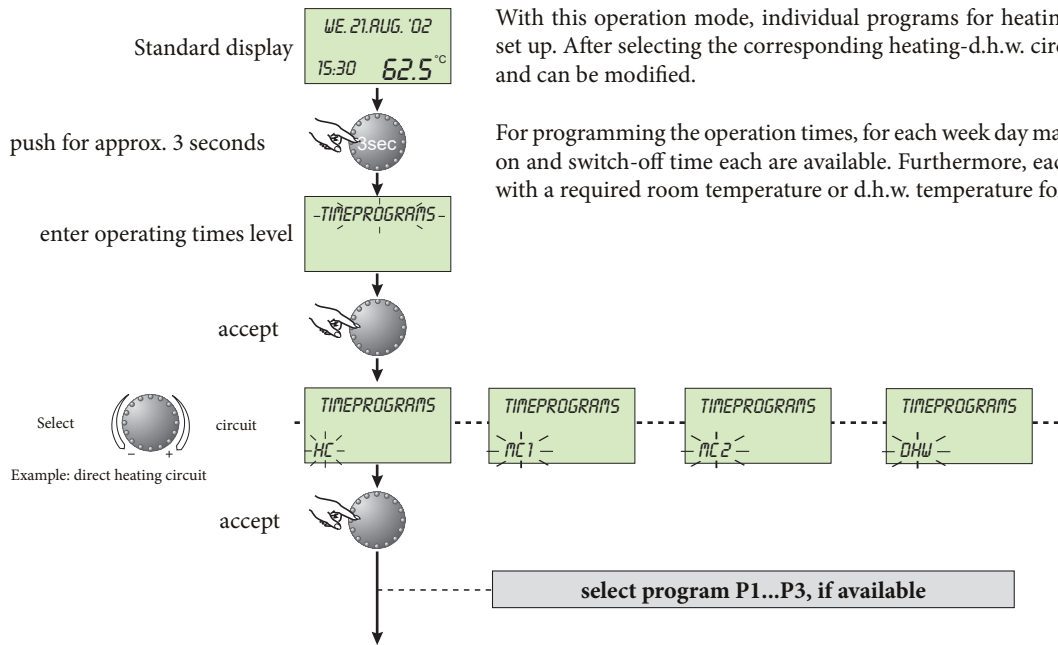

With this operation mode, individual programs for heating and domestic hot water mode can be set up. After selecting the corresponding heating-d.h.w. circuit, the standard program (P1) is called and can be modified.

For programming the operation times, for each week day maximum 3 heating cycles with one switch-on and switch-off time each are available. Furthermore, each heating-d.h.w. cycle can be combined with a required room temperature or d.h.w. temperature for the duration of the cycle.

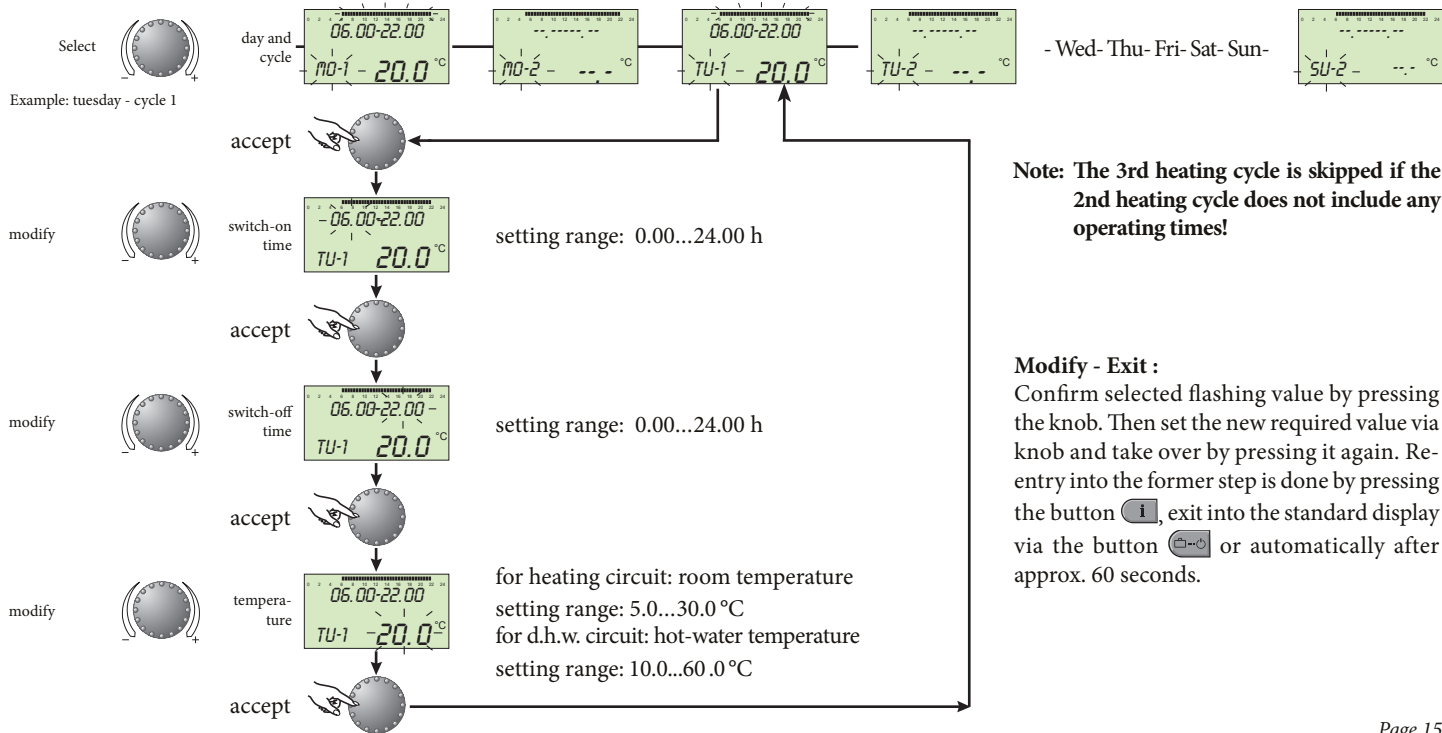

Copying operating times.

This function allows to copy operating times of any day of the week to other days (Mo - Su) or to the whole week (1 - 7) or parts of a week such as workdays (1 - 5) or weekends (6 - 7).

Standard display

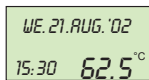

push for approx. 3 seconds



enter operating times level

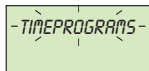

accept



Select



circuit

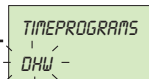
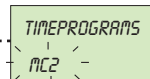
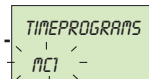
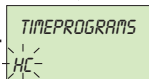

Example: direct heating circuit

accept



Note: Turn knob anti-clockwise and select Copy Day

Select



copy

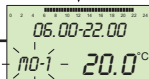



Select
Example: Monday

source

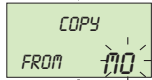

Setting range:
Monday (MO)...Sunday (SU)

accept

First selection
Example: Monday
to Friday

day(s)
to copy

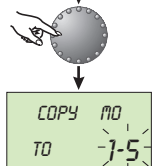

Setting range:
days (MO...SU), whole week (1-7)
working days (1-5), week-end (6-7)

copy

confirmation

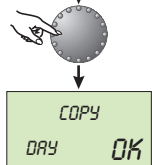

source and destination are identical

Select
Example: Saturday
and Sunday

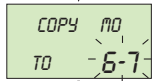

next desti-
nation



if necessary select and take over further destina-
tions in the same way.

etc.

Modify - exit:

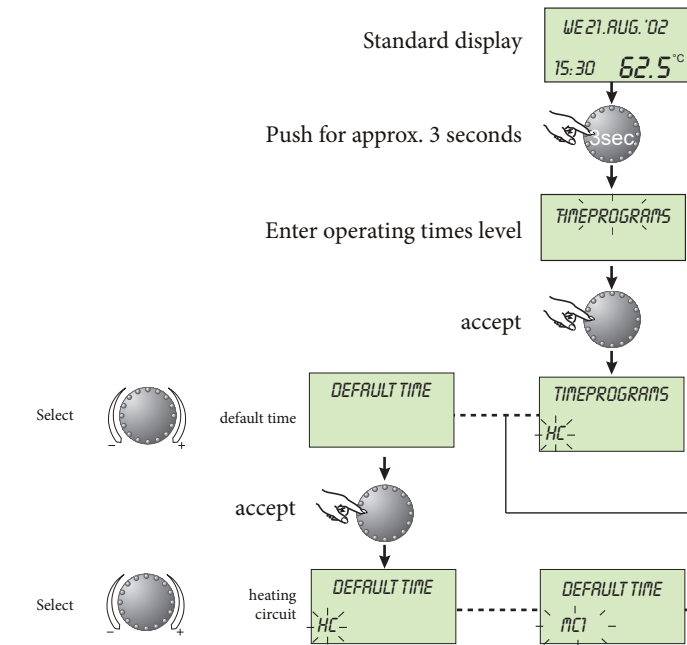

Confirm selected flashing value by pressing the knob. Then set the new required value via knob by pressing it again. Re-entry into the former step by pressing the button , exit into the standard display via the button  or automatically after approx 60 seconds.



Example: direct heating circuit HC

When doing this operation the operating times programs which were changed will be definitely lost and replaced by the standard programs indicated in the tables below.

Modify - exit:

Confirm selected flashing value by pressing the knob. Then set the new required value via knob and take over by pressing it again. Re-entry into the former step is done by pressing the button , exit into the standard display via the button  or automatically after 60 seconds.

Note: Turn the knob till displaying "Default time"

Circuit(s) in which the standard program is reloaded

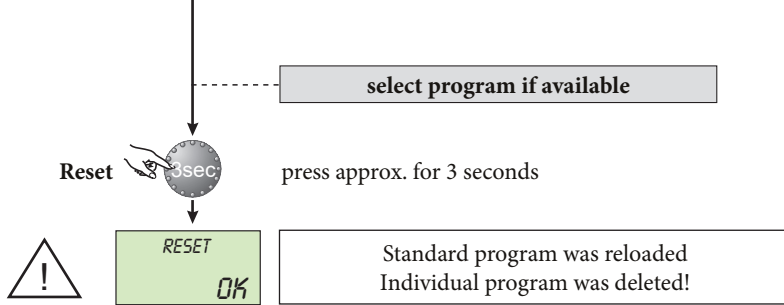

Note: The programs P2 e P3 appear only if the option P1-P3 in the System level is activated.

Standard operating times programs are the following:

Standard operating times program P1

Circuit	Day	Heating from-till
All heating circuits (HC, MC1, MC2)	Mo-Su	06.00 - 22.00
Domestic hot water (DHW)	Mo-Su	05.00 - 22.00

Standard operating times program P2
(see page 20)

Circuit	Day	Heating from-till
All heating circuits (HC, MC1, MC2)	Mo-Th	06.00-08.00 16.00-22.00
	Fr	06.00-08.00 13.00-22.00
	Sa-Su	07.00-23.00
Domestic hot water (DHW)	Mo-Th	05.00-08.00 15.30-22.00
	Fr	05.00-08.00 12.30-22.00
	Sa-Su	06.00-23.00

Standard operating times program P3
(see page 20)

Circuit	Day	Heating from-till
All heating circuits (HC, MC1, MC2)	Mo-Fr	07.00-18.00
	Sa-Su	reduced
Domestic hot water (DHW)	Mo-Fr	06.00-18.00
	Sa-Su	reduced

PARAMETERS CONFIGURATION.

Setting of system parameters (for the technician).

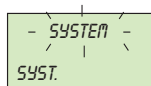

This level includes general delimiting parameters and options referring to the corresponding heating system.

Entry: See “Programming of functioning parameters” page 12-13.

Exit: Button  or automatically after 60 seconds

Modify: Confirm selected flashing parameter by pressing the knob. Then set the new required value via the knob and accept by pressing the knob again.

Entry:

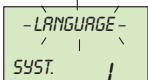

Language choice

setting range:

I = ITALIAN

GB = ENGLISH

F = FRENCH

D = GERMAN

factory preset: I

All information appearing on the display are available in the languages Italian, German, English and French. After entry as first parameter appears the language selection. The required language can be selected according to the above assignment.

next parameter

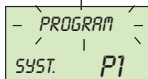

Operating times program

setting range: P1, P1-P3

standard: P1

This parameter specifies the number of the cleared time programs. With the regulation P1 only one operating times program is available. With the setting value P1-P3 all three programs are cleared and taken into consideration for programming operating times.

next parameter



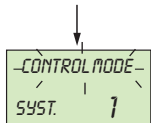

next parameter

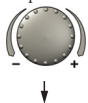



Control mode

setting range: 1 = common mode 2 = separated mode

factory preset: 2

Common control mode:

The selected operational mode via button  (holiday, absent, party, auto, etc.) and the temperatures set via button  and  applies to all heating circuits together (MC 1, MC 2 and HC).

Separated control mode:

Each heating circuit can be assigned with its own operational mode and temperature settings. With separated mode all regulations refer also only to the previously selected heating circuit as shown below.

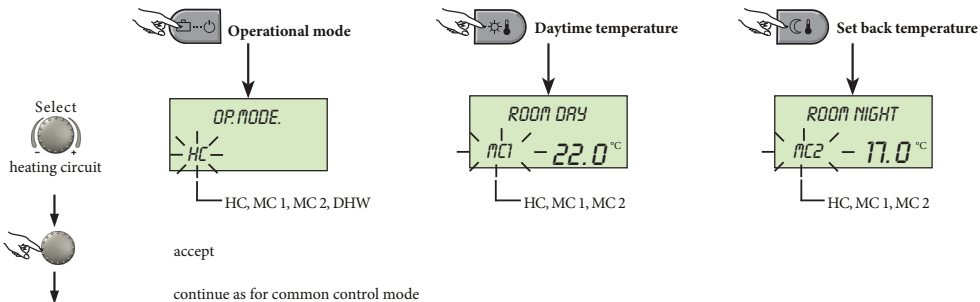

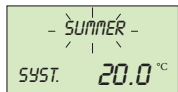

next parameter

**Summer switching-off.**

setting range: OFF, 10,0 to 30,0 °C

factory preset: 20.0 °C

This parameter specifies the heating delimiting value compared to current outside temperature and puts the heating system automatically out of service as soon as the outside temperature exceeds the set heating delimiting value. During summer switching-off the pumps of all heating circuits are activated each day for approx. 20 seconds to protect them against corrosion and all available mixing valves are opened for a short time (anti blocking protection).

With the regulation OFF, summer switching-off is not effective.

Hot water production is not affected by summer switching-off.

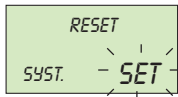
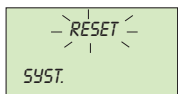
**Parameter-reset.**

This function resets all individually entered values in the programming level to the factory preset.

Exception: time-date, operating times.

Reset: Press knob for approx. 5 seconds while indication SET is flashing, until standard display appears.

Important: reset may only be executed if all individually entered values shall be replaced by the factory preset values! Do not use except when absolutely needed and only after calling the technician.



Domestic hot water parameters setting.

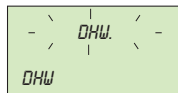

Entry:

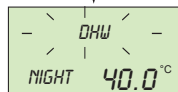

next parameter



This level includes the necessary parameters for programming the hot water economic temperature and the legionella protection.

Hot water economic temperature.

Setting range: 10.0 °C up to the required hot water temperature.
Factory preset: 40 °C.

This parameter specifies the value of the reduced hot water temperature outside P1 operating cycle times as well in the operational mode ABSENT for the duration of absence.

Legionella protection (day).

Setting range: OFF, MO SU, ALL
Factory preset: OFF

The legionella protection serves to avoid a legionella infestation inside the hot water cylinder and is activated on the selected weekday or on every day. If the hot water temperature is below 65 °C, the cylinder is heated. With the regulation OFF this function is not effective.

Entry: see page 12-13.

Exit without

modifications: via button  or automatically after 60 sec.

Application: supporting temperature inside the cylinder in order to avoid a cooling down of the tank.

Important: Other legionella protection times can be regulated exclusively by the heating system specialist.

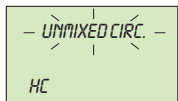

This level includes the parameters required for programming the reduced heating mode and the adaptation to the corresponding heating system.

Entry: see page 12-13.

Exit without

modifications: via button  or automatically after 60 sec.

Entry:

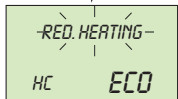
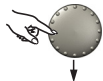

Reduced heating mode.

setting range: ECO, RED

factory preset: ECO

During the reduced operation the following modes can be selected:

ECO: At outside temperatures above the set anti-freeze temperature, the heating circuit pump is switched-off completely.

At temperatures below frost protection the heating circuit is controlled with reduced heating characteristics according to the required reduced temperature (see page 4).

RED: During the reduced mode the heating circuit pump remains activated. The temperature does not drop below the set minimum temperature value.

Application:

objects with high insulation values.

Application:

objects with low insulation values

next parameter



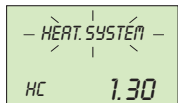

Adaptation to the heating system (value m).

setting range: 1.00 to 10.0

factory preset: 1.30

This parameter refers to the type of the heating system inside the heating circuit and has to be adapted to the exponents of the corresponding consumer (underfloor-radiator-convector). The setting value specifies the curvature of the heating curve.

Applications:

the following setting values are recommended for the below-mentioned applications:

Setting value	Application
1.1	Heating curve for underfloor heating systems or other static heating surfaces
1.3	Normal standard heating curves for radiators
3.0 . . . 4.0	Heating curve for convectors
4.0 . . . 10.0	Special heating curve for ventilators with high starting temperatures

Time - date.

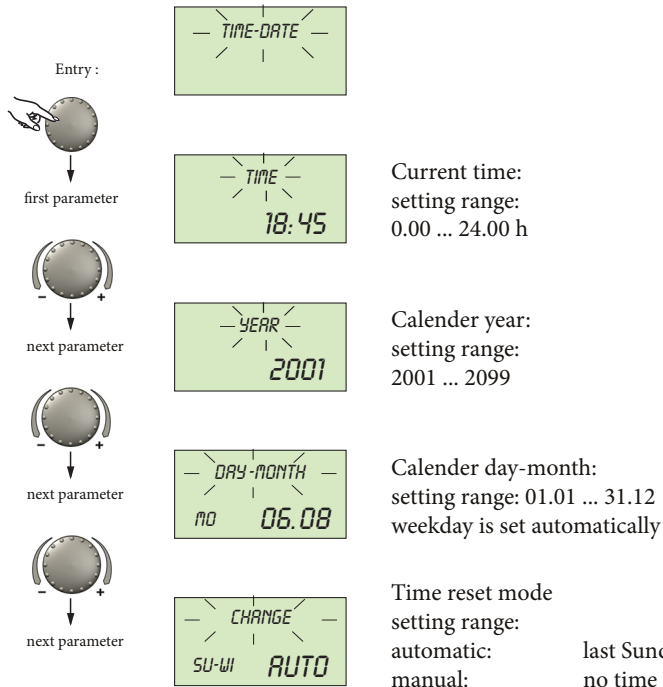

Entry: see page 12-13.

Exit: via button  or automatically after 60 sec.

The beside standing values are factory preset and normally need not be updated.

The internal pre-programmed calendar provides an automatic time change at the yearly repeating summer- winter time reset-dates.

If required, the automatic time reset can be switched off (manual reset).

ERROR MESSAGES.

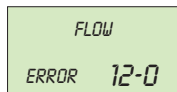

Example for error messages “sensor” (short or open circuit)
error code 10...20 with index 0 or 1

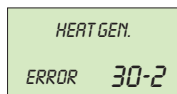

Example for error messages “boiler” (control status)
error code 30...40 with index 2...5

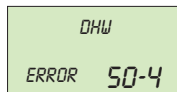

Example for logical error messages (control functions):
error code 50...60 with index 2...4

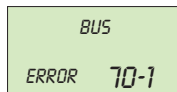

Example for error messages “data bus” (address error)
error code 70 with index 0 or 1

The instrument is equipped with an extensive error diagnostic features, The error displayed takes priority over other displays.

Note: error messages only appear alternating with the standard display.



In case of error messages the heating specialist has to be informed!

Emission measurement.

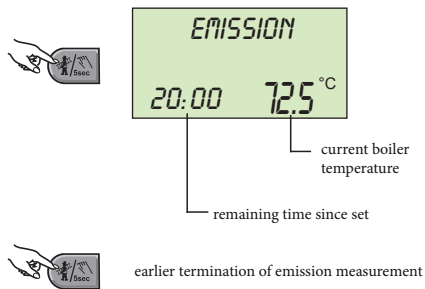

Button for the emissions measurement from authorized personnel.

When pressed, all circuits operate at their maximum preset temperature for 20 minutes. After this time the emission measurement can be activated again.

The remaining time appears in the display during the whole measurement.

Emission measurement can be terminated at any time by pressing the button .

Attention: The domestic hot water temperature reaches the preset maximum value. Danger of scalding on high adjustments!



MANUAL MODE (FOR TECHNICIAN).

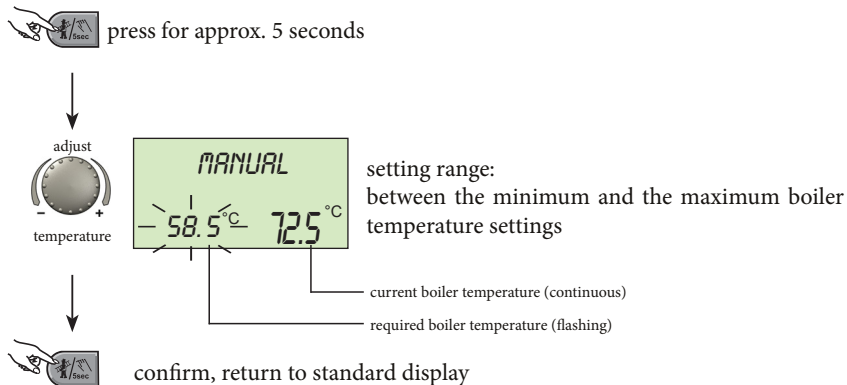

Continues heating and domestic hot water operation in case of malfunctioning.

When the button is pressed for more than 5 seconds while showing the standard display, the control unit is switched over to manual mode. All control functions are released, the required boiler temperature can be adjusted by the knob. The pumps of all heating circuits including the hot water loading pump remain in operation. Mixer controls become disengaged so that they can be manually adjusted as required.

To return to the previous selected program press button



Attention!



The domestic hot water temperature reaches the preset boiler temperature.

Danger of scalding on high adjustments!



Take the relevant security measures to protect underfloor heating systems against overheating (i.e. switching-off circulation pump via external flow thermostat).

PRODUCT SPECIFICATIONS.

In accordance with Regulation 811/2013 the temperature control device class is:

Class	Contribution to the environmental heating seasonal energy efficiency	Description
VI	+4%	Administrator kit
VIII	+5%	Administrator kit coupled to 3 environment sensors

Follow us

Immergas Italia



immergas.com

Immergas S.p.A.
42041 Brescello (RE) - Italy
Tel. 0522.689011
Fax 0522.680617

Certified company ISO 9001

